

(19)  
(12)

(KR)  
(A)

(51) 。 Int. Cl. <sup>7</sup>  
B41J 2/175

(11)  
(43)

2002 - 0009280  
2002 02 01

(21) 10 - 2000 - 0042863  
(22) 2000 07 25

(71)

3 416

(72)

334 - 802

663 - 1 4 107 - 201

(74)

:

(54)

, 가 가 가 ,  
가 가 .

2

, , ,

1a 1b .

2

3a 3d 2

\* \*

101... 102...

110... 111...

120... 121...

130... 131...

132... 133...

133A... 133B...

, (Thermal) ,

1a 1b (Thermal) (10) 1a (1  
1) (13) 가 (14) (1) 가 (13)  
(13) 가 (12)

, (20) 1b (22)  
(21) (25) 가 , (24) 가  
(23)

, 가 (Thermal) , 가  
가 가

, 가



3a (133B) (132) 가 (101) 3b (102) (133A)가 (1)가

(133A) ( )가 3c (132)가 (102) (131) (1) 가 (121)

4d 가 (1)가 (121) (1)

131) 1) (135) 가 (13

가 가 가 가 가

(57)

1.

2.

1

가

3.

2 , ,

;

4.

2 , ,

가

5.

4 , ,

가

가

6.

1 5 , ,

7.

;

가 가 ;

;

가

;

8.

7 , ,

1a

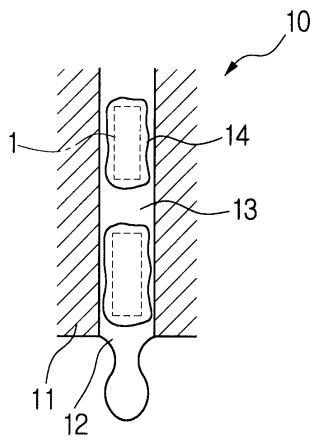

1b

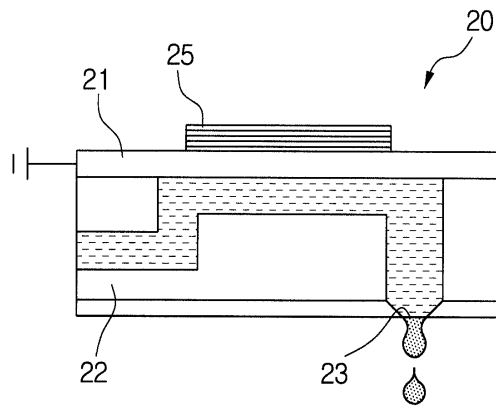

2

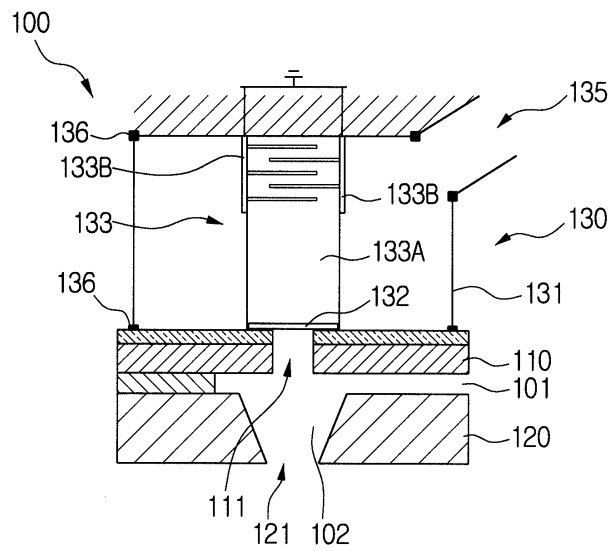

3a

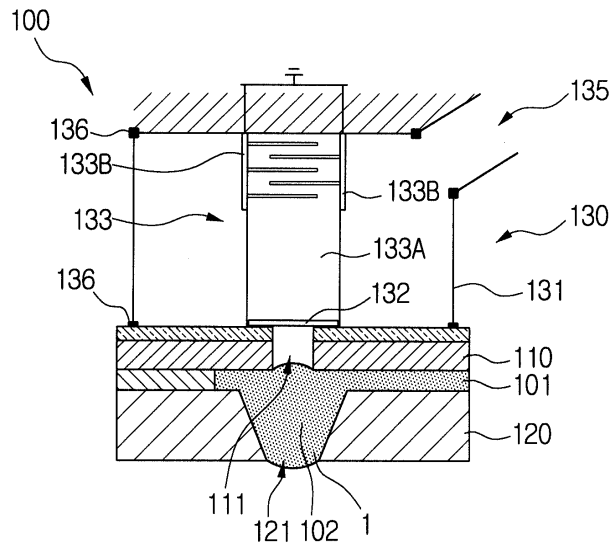

3b

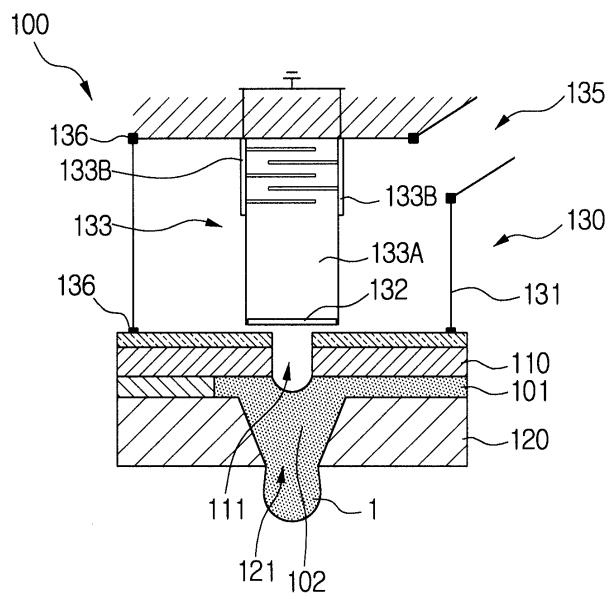

3c

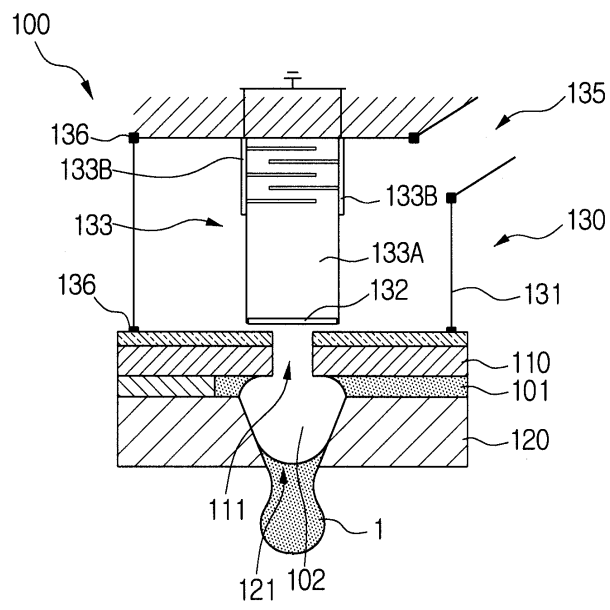

3d

