

W. G. PRICE.
TRUCK FRAME.

APPLICATION FILED AUG. 18, 1906.

2 SHEETS—SHEET 1.

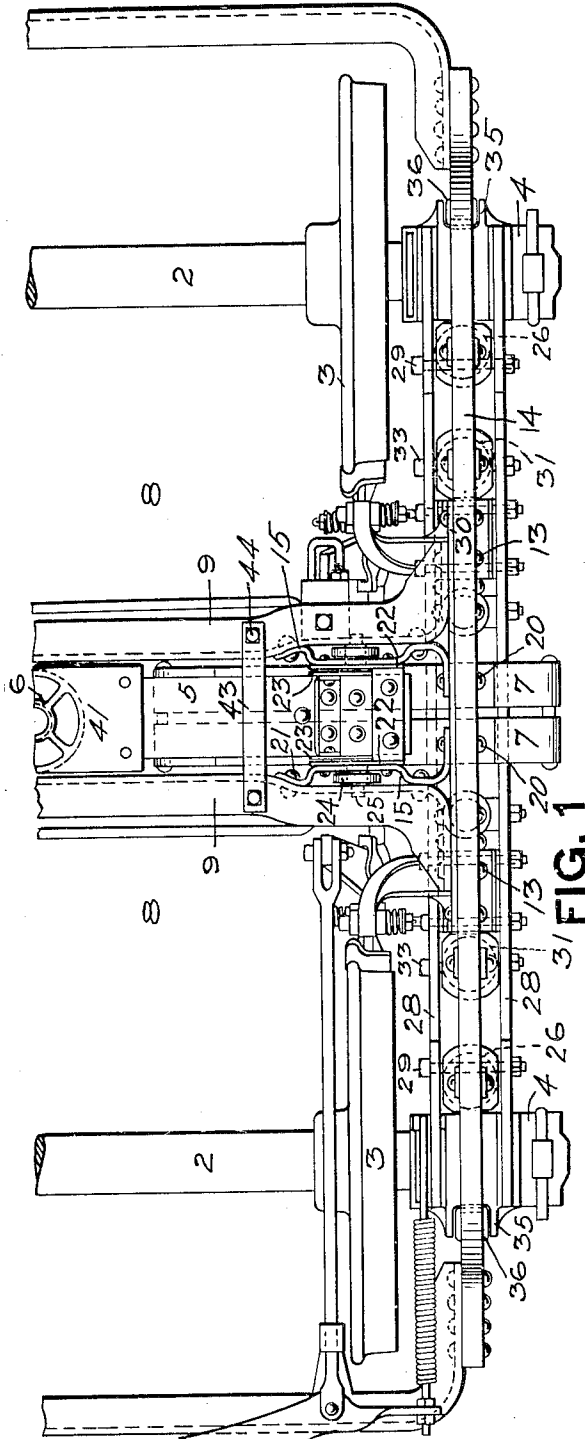

FIG. 1

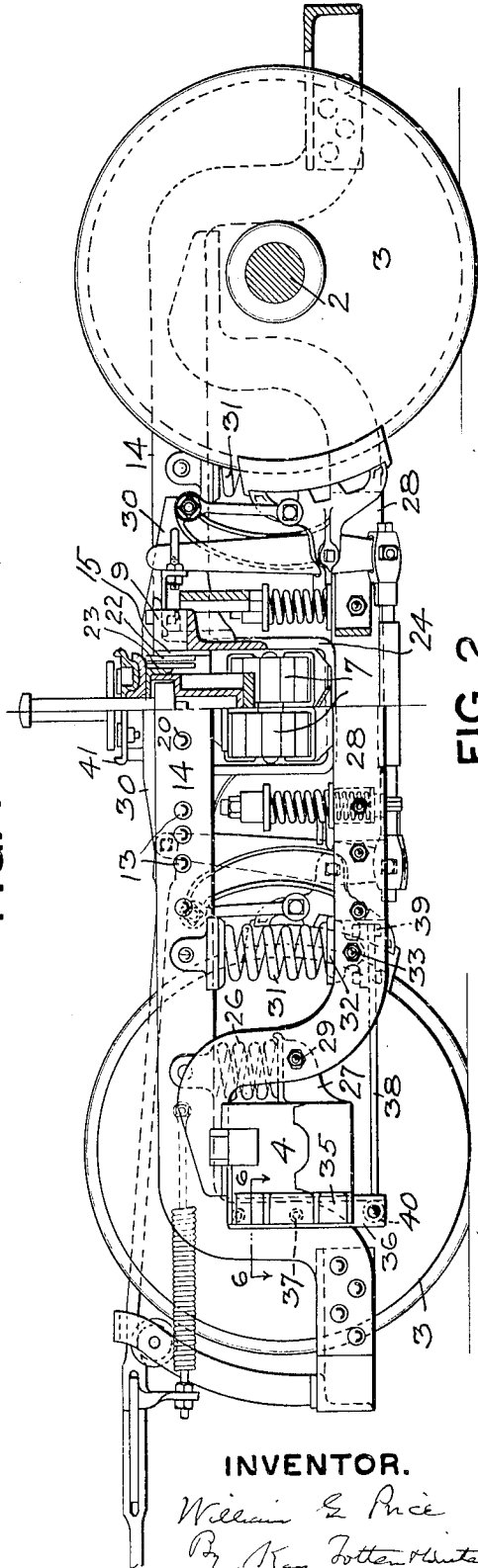

FIG. 2

WITNESSES.

J. R. Keller
Robert C. Zetter

INVENTOR.

William G. Price
By Kay Zetter & White
attorneys

W. G. PRICE.
TRUCK FRAME.

APPLICATION FILED AUG. 18, 1906.

2 SHEETS—SHEET 2.

FIG. 3

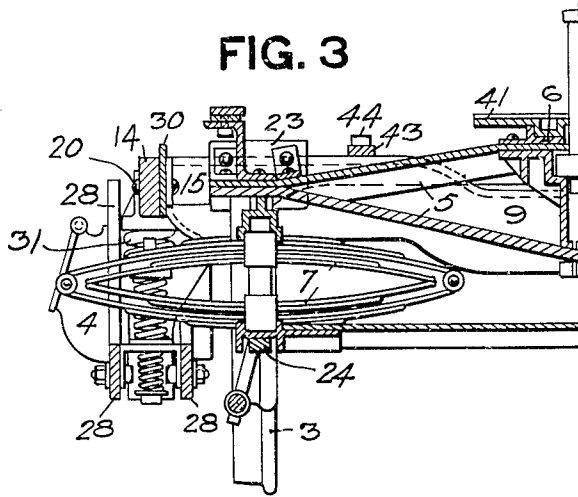

FIG. 5

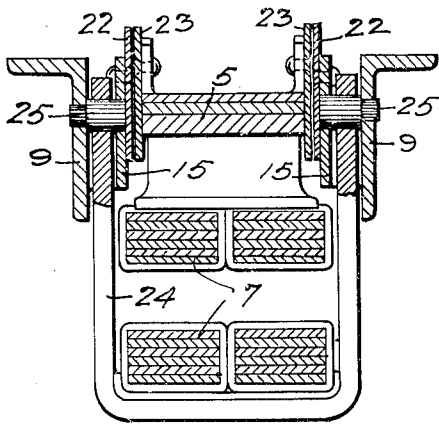

FIG. 6

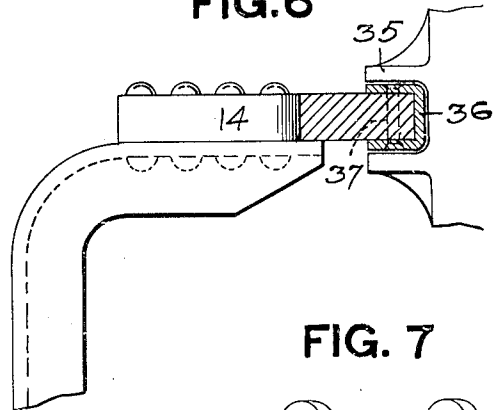

FIG. 7

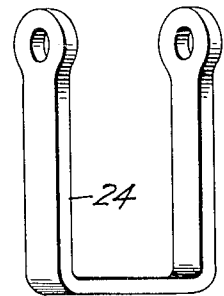

FIG. 4

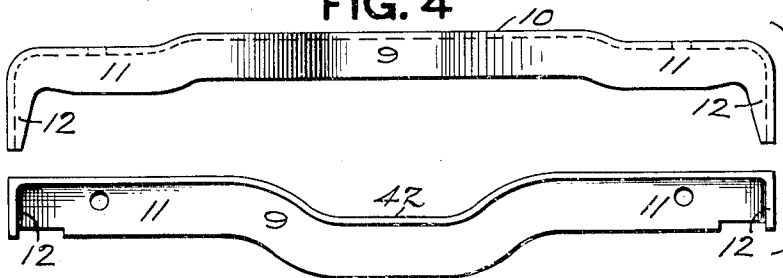
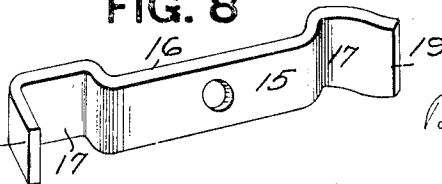

FIG. 8



WITNESSES.

J. R. Keller
Robert C. Totten

INVENTOR.

William Price
By Kay Totten & White
attorneys

UNITED STATES PATENT OFFICE.

WILLIAM G. PRICE, OF NEW CASTLE, PENNSYLVANIA.

TRUCK-FRAME.

No. 872,016.

Specification of Letters Patent.

Patented Nov. 26, 1907.

Application filed August 18, 1906. Serial No. 331,139

To all whom it may concern:

Be it known that I, WILLIAM G. PRICE, a resident of New Castle, in the county of Lawrence and State of Pennsylvania, have invented a new and useful Improvement in Truck-Frames; and I do hereby declare the following to be a full, clear, and exact description thereof.

My invention relates to trucks, and more especially to motor trucks having a swing bolster.

One of the objects of my invention is to so construct and locate the transoms with reference to the bolster as to make the wheel base as short as possible and provide for the insertion of the bolster hangers between the transoms and the bolster.

A further object is to provide a very rigid truck frame, one which will stand heavy shocks and collisions, and one in which the chafing or wear on the parts is reduced to a minimum.

To these ends my invention comprises the novel features hereinafter set forth and claimed.

In the accompanying drawings Figure 1 is a plan view of one side of my improved truck; Fig. 2 is a side elevation partly in section; Fig. 3 a cross-section taken at the bolster; Fig. 4 shows plan and side views of the transom; Fig. 5 is a cross sectional view through the transoms, bolster and hanger; Fig. 6 is a section on the line 6—6 Fig. 2; Fig. 7 is a perspective view of the bolster hanger; and Fig. 8 a perspective view of the bolster hanger bracket.

The numeral 2 designates the axles carrying the wheels 3, said axles being journaled in suitable journal boxes 4, in the ordinary manner. The bolster 5 illustrated is of a common type and as it forms no part of my present invention I will not describe the same in detail. This bolster is provided with the ordinary center bearing plate 6, and suitable springs 7 are employed.

In electric trucks, it is not desirable to have the wheel base too long, and the length of the wheel base is determined by the width from the outer edge of one transom to the outer edge of the other transom and by the space occupied by the motors between the center of the axle and the side of the transom as shown by the space marked 8. In order to make the wheel base as short as possible, it is

necessary to locate the transoms as close as possible to the bolster, while at the same time it is also necessary to locate the transoms far enough away from the bolster, so that the bolster hanger and bolster hanger bracket can be inserted between the transoms and the bolster. To provide for this, I employ the transoms 9, which may be formed of angle bars of suitable dimensions. As shown in Fig. 4 the transoms are bent to form the inwardly projecting portion 10, said projecting portion extending from the center line of the truck in both directions for a suitable distance, thereby bringing the transom for the greater part of its length closer to the bolster and increasing the distance between the transom and the axle to receive the motor. In bending this portion 10 of the transom, I obtain the portions 11 at each end of the transom, which provide corresponding recesses between the same and the bolster for the reception of the bolster hangers, as hereinafter set forth. The extreme ends of the transoms are bent to form the right angle portions 12, by means of which the transoms are secured by rivets 13 to the side frames 14.

The bolster hanger brackets 15, illustrated in Fig. 8 have the inwardly bent portions 16, and the outwardly projecting portions 17, and the end flanges 18 and 19. These brackets are secured to the side frames 14 by rivets 20 passing through the flanges 18 and side frames 14, said flanges being turned in the opposite direction to the bent ends 12 of the transoms 10. Rivets 21 secure the flanges 19 of the brackets 15 to the transoms. By this construction the brackets act practically as braces and give a strong and rigid connection between the transoms and the side frames to guard against heavy shocks and collisions.

Interposed between the brackets 15 and the bolster, are the wear plates 22, secured to the brackets 15, and similar wear plates 23 secured to the bolster. In this manner I provide against the wear of the brackets from contact with the bolster.

The bolster hangers 24 are U-shape in form and pass down beneath the bolster springs 7 so as to support the bolster, the ends of the hangers extending into the spaces between the bolster and the ends of the transoms, and being secured by pivot pins 25 to the transoms and to the hanger brackets

15. The bolster hangers are thus supported between the transoms and the hangers, making a very strong form of construction.

The load on the bolster is transmitted 5 through the hangers 24 to the transoms 9 and bolster hanger brackets 15, and thence to the side frames 14. The equalizer bar springs 26 support the side frames 14, said springs resting upon lugs 27 on the journal 10 boxes 4, said lug being secured to the equalizer bar 28 by the bolt 29. The side frames 14 transmit the load to the equalizer bar springs 26, and where very heavy loads are to be carried the side frames 14 are not 15 sufficiently strong to transmit the load from the transoms to the springs 26. I prefer to employ, therefore, the side frame stiffener 30, which is riveted to the side frame between the transoms and bracket 15 and said 20 side frame. This side frame stiffener may vary in thickness and width to suit the various weights to be carried. Sometimes when very heavy loads are to be carried, it is necessary to use larger springs than can 25 be placed between the equalizer bars. I have accordingly provided springs 31, which rest upon spring seats 32 secured to the equalizer bars 28 by the bolt 33.

In electric motor trucks there is often 30 considerable chafing and wearing of the metal on the journal boxes and side frames where these parts come in contact. To provide against such wear the journal box 4 has the jaw 35 which engages or partly surrounds a U-shaped wear piece 36, riveted to the side 35 frame 14 by the rivets 37. When the motors are propelling the car they push the wheels with the journal boxes 4, and equalizer bars 28 forwardly, while the frame 14 is held back 40 by the inertia of the car. Likewise, when the brakes are applied to the wheels, the same action takes place except in opposite directions, which causes the journal boxes to press hard against the wear pieces 36, and 45 as these parts have a vertical movement with reference to each other, owing to the action of the springs 26 and 31, the surface of the journal boxes and side frame wear pieces 36, where they come in contact, have 50 the metal worn away. To guard against this action which brings these parts into contact with each other, I provide a tie 38, preferably a spring plate which is secured to the spring seat 30 by the bolts 39, which 55 passes through an eye 40 in the end of the plate 38. The length of the plate 38 is such that the journal boxes 4 are held out of contact with the wear pieces 36 in direction longitudinal of the track. As the plate 60 38 may be several inches thick and is rigidly secured by bolts at one end and is rigidly secured between the two sides of the wear piece 36 at the other end, the side frame 14 and the wear piece 36 are prevented from 65 moving in a lateral direction across the track,

and consequently the said wear piece and the sides of the journal box jaw 35 are practically prevented from coming in contact so as to wear away their surfaces. In this way I provide against the wear of the journal box, 70 as it may move in a vertical or lateral direction. The plate 38 is preferably made of spring steel, tempered and sufficiently thin, so that it will bend in a vertical direction to allow for the oscillation of the 75 springs 26 and 31.

In order that the transoms shall be low enough to directly support the nose or lug of motor and also to give clearance to the car body center plate 41 when the truck is 80 swiveling around curves I bend down the central portion of the transom as clearly shown at 42 in Fig. 3. The transoms 9 are connected by the bars 43 secured by the bolts 44. 85

What I claim is:

1. In a truck, the combination of side frames, a bolster, and transoms secured to the side frames and having end portions extending substantially perpendicular to the 90 side frames and having portions intermediate said end portions projecting toward the bolster. 85
2. In a truck, the combination of side frames, a bolster, and transoms secured to the side frames and having end portions projecting inwardly substantially perpendicular 95 to the side frames and then bent toward the bolster for a portion of their length intermediate their ends. 100
3. In a truck, the combination of side frames, a bolster, transoms having end portions substantially perpendicular to the side frames and portions intermediate their ends projecting toward the bolster, the ends of 105 said transoms lying at right angles to the main portion and secured to said side-frames. 100
4. In a truck, the combination of a bolster, side-frames, transoms having end portions substantially perpendicular to the side 110 frames and portions intermediate their ends projecting toward the bolster, the ends of said transoms being bent at right angles and secured to said side frames. 110
5. In a truck, the combination of side 115 frames, a bolster, and angle-bar transoms secured to the side frames and projecting substantially perpendicularly to the side frames and then bent to project toward the bolster for a portion of their length intermediate 120 their ends. 115
6. In a truck, the combination of side-frames, transoms with their ends turned at right angles and secured to said side-frames, bolster hanger-brackets with flanges turned 125 at right-angles in the opposite direction to said transom ends and secured to said side-frames and transoms. 120
7. In a truck, the combination of side frames, a bolster, transoms secured to the 130

side frames and having portions adjacent their ends projecting away from said bolster, hanger-brackets, and bolster-hangers passing up in the space between said projecting portions of said transoms and said brackets.

8. In a truck, the combination of side frames, a bolster, transoms secured to the side frames and having portions adjacent their ends projecting away from said bolster, hanger-brackets, and bolster-hangers passing up in the space formed between said projecting portions of said transoms and said brackets and supported by said transoms and brackets.

9. In a truck, the combination of side frames, a bolster, transoms connecting the side frames and having portions adjacent their ends projecting away from said bolster, hanger-brackets, and bolster-hangers passing up in the space formed between said projecting portions of said transoms and said brackets, said brackets being secured to the side frames and transoms.

10. In a truck, the combination of transoms, a bolster, a bolster hanger bracket secured to the transom, and a wear-plate interposed between said bolster and bracket.

11. In a truck, the combination of a bolster, side frames, transoms, and side frame stiffeners between said transoms and side frames and secured to both.

12. In a truck, the combination of a

bolster, side-frames, hanger-brackets, and side-frame stiffeners between said transoms and brackets and said side frames, and secured to both.

13. In a truck, the combination of side frames, journal-boxes movable in said side-frames, equalizer bars bearing on said boxes, and connections between said side-frame and equalizer bars to hold said journal-boxes from contact with said side-frames.

14. In a truck, the combination of side frames, journal-boxes movable on said side-frames, equalizer bars bearing on said boxes, and a plate connecting said side-frames to said equalizer bars.

15. In a truck, the combination of side frames, journal-boxes movable on said side-frames, equalizer bars bearing on said boxes, and spring plates connecting said side-frames to said equalizer bars.

16. In a truck, the combination of side-frames, journal-boxes movable on said side-frames, wear-plates on said side-frames between said frame and boxes, equalizer bars, and plates connected to said wear plates and to said equalizer bars.

In testimony whereof, I, the said WILLIAM G. PRICE have hereunto set my hand.

WILLIAM G. PRICE.

Witnesses:

M. D. VOGEL,
F. W. WINTER.