

I. KEY.
LIFTING JACK.
APPLICATION FILED APR. 9, 1910.

970,239.

Patented Sept. 13, 1910.

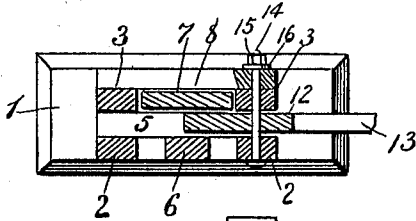
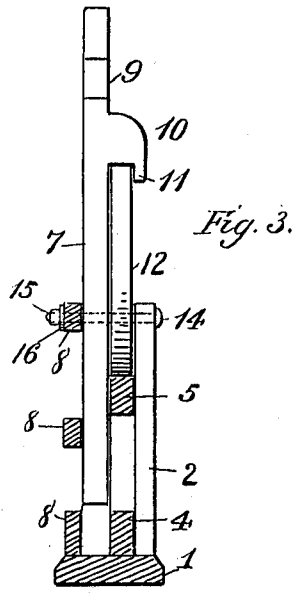
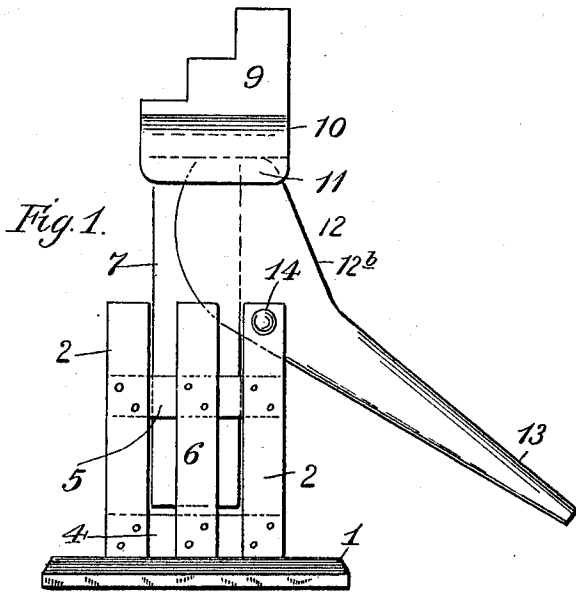

Fig. 5.

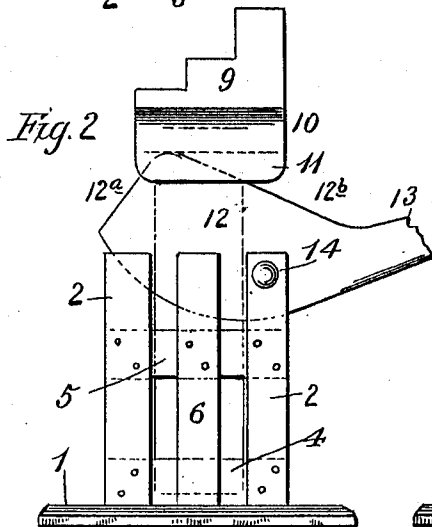

Fig. 2.

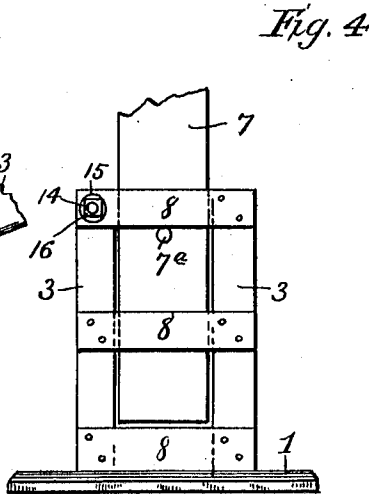

Fig. 4.

Witnesses
F. L. Curand.
Wm. Les Lamb.

Inventor
Isaac Key,
By *J. M. Kester*
Attorney

UNITED STATES PATENT OFFICE.

ISAAC KEY, OF FOWLERTON, INDIANA.

LIFTING-JACK.

970,239.

Specification of Letters Patent. Patented Sept. 13, 1910.

Application filed April 9, 1910. Serial No. 554,436.

To all whom it may concern:

Be it known that I, ISAAC KEY, a citizen of the United States, residing at Fowlerton, in the county of Grant and State of Indiana, have invented certain new and useful Improvements in Lifting-Jacks, of which the following is a specification.

My invention relates to improvements in what are termed generally lifting jacks, more especially for use in connection with vehicles, as in elevating the axle when it may be required to remove the wheels for lubrication.

It has for its object to carry out the aforesaid purpose in a simple, inexpensive and effective manner, as well as to provide for readily manufacturing the device and applying the same for use; also to minimize the expenditure of force or effort to effect the operation thereof, and to render the device or jack automatically locking under stress in sustaining the superposed vehicle-axle or other weight.

The invention consists of certain structural features or instrumentalities substantially as hereinafter fully disclosed and defined by the claims.

In the accompanying drawing illustrating the preferred embodiment of my invention: Figure 1 is a side elevation thereof, the lifting-bar and its actuating cam-lever being in effective position. Fig. 2 is a broken side view, the parts named being in depressed or ineffective position. Fig. 3 is a broken vertical section, produced through Fig. 1. Fig. 4 is an opposite side elevation to Fig. 1. Fig. 5 is a transverse section taken on a line extending horizontally through the pivot-bolt of the cam lever.

In carrying out my invention, I suitably construct or devise a preferably upright support or structure for suitably assembling and retaining the working parts, presently described, in operative position. Said support is formed of a base 1, upon which are superposed end pieces or uprights 2, 3 two being arranged at each end, the lower ends of said uprights being secured to opposite sides of an interposed longitudinal member or bar 4 centrally secured or bolted to the upper surface of said base, in the direction of its length. Said uprights are secured, a short distance below their upper ends, to, and thus suitably spaced apart for a purpose presently seen, by means of, a second bar 5 also interposed therebetween. A suitable

filling-in upright-piece or member 6 is secured to the bars 4 and 5, between two of the end-pieces or uprights 2, upon one side of the support, which filling-in piece, although serving in a measure as a guard against lateral movement of the hereinafter described cam-lever, may be replaced by any other suitable substitute, or it may be dispensed with entirely.

A lifting bar 7 preferably rectangular in cross-section, as well as in general outline, is arranged between the end uprights 3 and adapted to be vertically movable therebetween and guided thereby, said lifting bar being retained between said end uprights as against outward lateral displacement by means of transverse bars 8 secured to the end pieces or uprights 3, at the lower and upper ends thereof and intermediate of said ends respectively. The upward movement of the lifting bar is controlled or limited by a stop 7^a projecting therefrom and adapted to engage the uppermost cross-bar 8. Said lifting bar has its upper end equipped with a stepped member or head 9 for application to, or engagement with the vehicle shaft or axle which it may be desired to lift, with its wheel or wheels, as in providing for readily displacing the latter, for lubricating the axle or shaft. The stepped formation of the lifting bar head or member 9 provides, as is apparent, for the accommodation or adjustment of the same initially to vehicle-axes or shafts according to the size of the wheels, whether the same be of a greater or less diameter, as will be readily understood. Said head or member 9 may be extended rearwardly and forwardly beyond the corresponding edges of the lifting bar 7 for increasing its number of steps, as circumstances may require, as will also be readily appreciated. Said member or head is provided, along its base, at a point contiguous to its intersection with the lifting-bar, with a lateral or right-angled extension or offset 10, which may, itself, be provided with a depending flange or guard 11 along its longitudinal free edge, the purpose of which will be apparent later.

A cam lever 12 for actuation manually, having a suitable handle extension 13 for that purpose, is fulcrumed in the upper ends of the rear upright supports; a pivot bolt 14 being preferably employed therefor, inserted through said lever and through the upper ends of the uprights 2, 3, and the uppermost

transverse bar 8, said pivot bolt being suitably equipped with a nut 15 and a washer 16 for aiding its retention in place. The lever 12 has its cam formation preferably rounded or convex upon the forward lower edge, while the extreme forward upper end of said cam-formation is produced upon a right line, as at 12^a, said formation being also produced rearwardly of said right line with a corresponding surface 12^b intersecting the first-referred to line at about a right angle. The guard or flange 11 previously described is designed to retain the effective forward end of the lifting bar actuating lever in true working alinement with the offset of the lifting bar; it also has the effect to guard the surfaces of contact between the offset and the lever, as in excluding dirt therefrom, which would finally render ineffective the proper working action of the device or jack. It is also observed that by providing the head of the lifting bar with the lateral extension or offset, the cam lever is adapted to provide for direct action in the working of the lifting bar, also to shorten the leverage and otherwise improve the operation of the device. It will also be noted that the upper right lined surface 12^a of the forward end of the cam lever 12 is adapted, by moving its handle extension downwardly, to abut square against the under side of the lateral offset or extension 10 of the head 9 of said lifting bar and to deliver a rearward and upward thrust upon said offset or extension; the location of the pivot bolt of said lever being in vertical alinement with the line of engagement between said lever and offset, and the downwardly exerted pressure produced by the handle extension of said lever, aiding to bring about such upwardly and rearwardly thrusting action which results in automatically locking the lever, and accordingly the lifting bar in effective position under the superposed weight.

My invention, it will be thus observed, is highly useful and effective for its intended purpose, as well as adapted to be automatically locked in its effective or sustaining position, the same being also simple and inexpensive of manufacture, in addition to possessing certain other advantages as above disclosed.

I claim—

1. A lifting-jack comprising a lifting bar having a head at its upper end, said head having a lateral offset at its base, being at

the point of intersection between the upper end of said lifting bar and said head, said offset having a depending flange at its longitudinal free edge, a cam lever having its pivot arranged in vertical alinement with the line of engagement therebetween and said offset of the lifting bar, said cam lever being adapted to engage said offset and exert an upward and rearward thrust upon the under side of said offset, and supporting means for said lifting bar, said flange serving as a guard at the point of engagement between said offset and said lever.

2. A lifting-jack comprising a lifting-bar having a head at its upper end, said head having a lateral offset at its base, at the intersection of said head with said lifting bar, said offset having a depending flange at its longitudinal free edge, means for limiting the upward movement of said lifting bar, a cam lever having its extreme forward edge formed upon a right line, the thus formed right lined forward edge being adapted to abut squarely upon the under side of said offset, and supporting means for said lifting bar, said lever having pivotal connection with said supporting means in vertical alinement with said offset and at one side of said lifting bar.

3. A lifting-jack comprising a support including a base having a bar secured to the upper surface of its longitudinal center, uprights, two arranged at each end of said base and secured laterally to said bar, at their lower ends, a second bar vertically alining the first-referred to bar and arranged between and having said uprights secured thereto, transverse bars secured to said uprights, at their upper and lower ends, and intermediate of said ends respectively, a lifting-bar arranged between the end uprights upon one side of said vertically alined bars and guarded laterally by said transverse bars, said lifting bar having a head at its upper end, said head being provided with a lateral offset at its base, and a cam lever arranged upon the opposite side of said vertically alined bars, and fulcrumed upon one of the opposite end uprights and arranged to abut squarely against the under side of said offset.

In testimony whereof I affix my signature in presence of two witnesses.

ISAAC KEY.

Witnesses:

F. M. HARDESTY,
W. D. DYE.