



US 20160051119A1

(19) **United States**  
(12) **Patent Application Publication**  
**ROTHERHAM**

(10) **Pub. No.: US 2016/0051119 A1**  
(43) **Pub. Date: Feb. 25, 2016**

(54) **A JUG WASHING MACHINE**

**Publication Classification**

(71) Applicant: **ALDENAL PTY LTD**, Epping, NSW (AU)

(51) **Int. Cl.**  
*A47L 15/16* (2006.01)  
*A47L 15/00* (2006.01)

(72) Inventor: **Alan ROTHERHAM**, Epping, NSW (AU)

(52) **U.S. Cl.**  
CPC ..... *A47L 15/16* (2013.01); *A47L 15/0092* (2013.01)

(21) Appl. No.: **14/781,508**

(22) PCT Filed: **Apr. 2, 2014**

(57) **ABSTRACT**

(86) PCT No.: **PCT/AU2014/000350**

§ 371 (c)(1),

(2) Date: **Sep. 30, 2015**

A jug washing machine (50) to wash a jug (11) having a hollow body (12) and a lid (16). The jug washing machine (50) includes a cabinet (base) (51) having a door (52) that is operable to close the cabinet (51) so that they cabinet (51) and door (52) enclose a lower a chamber (53) and an upper chamber (54). The lower chamber (53) receives the jug body (12) in an inverted orientation while the upper chamber (54) receives a lid (16) with the surface (70) facing downwardly.

(30) **Foreign Application Priority Data**

Apr. 2, 2013 (AU) ..... 2013901112  
Oct. 25, 2013 (AU) ..... 2013904122

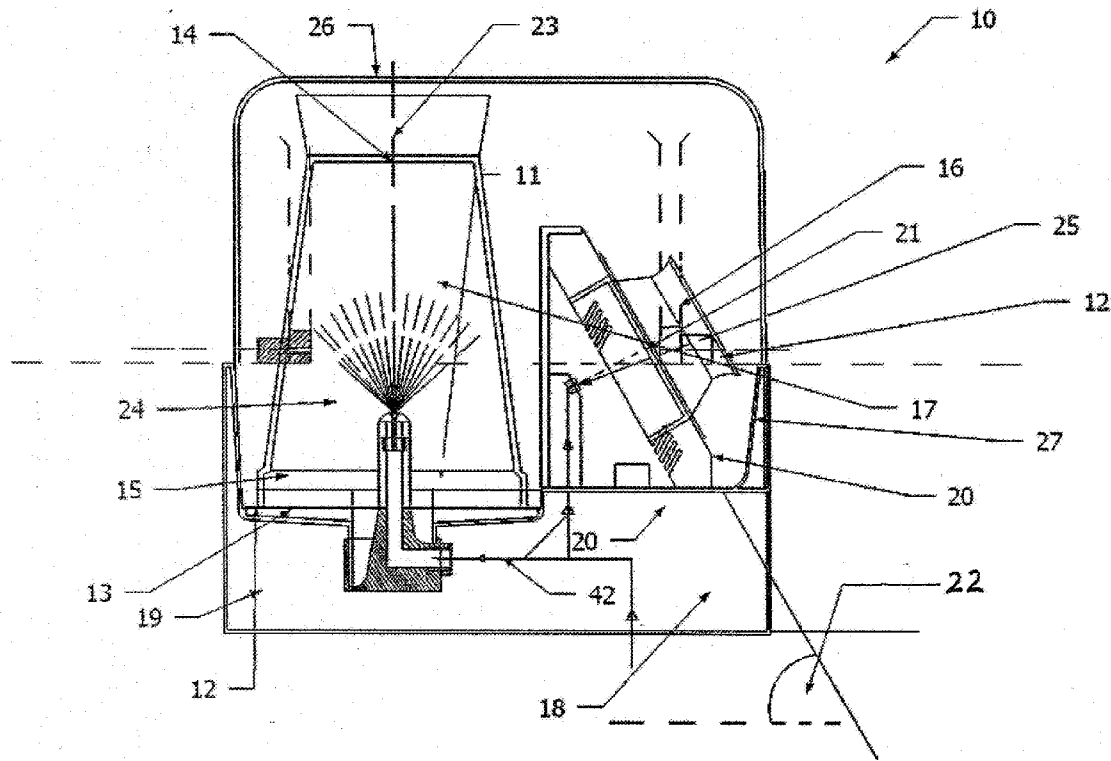

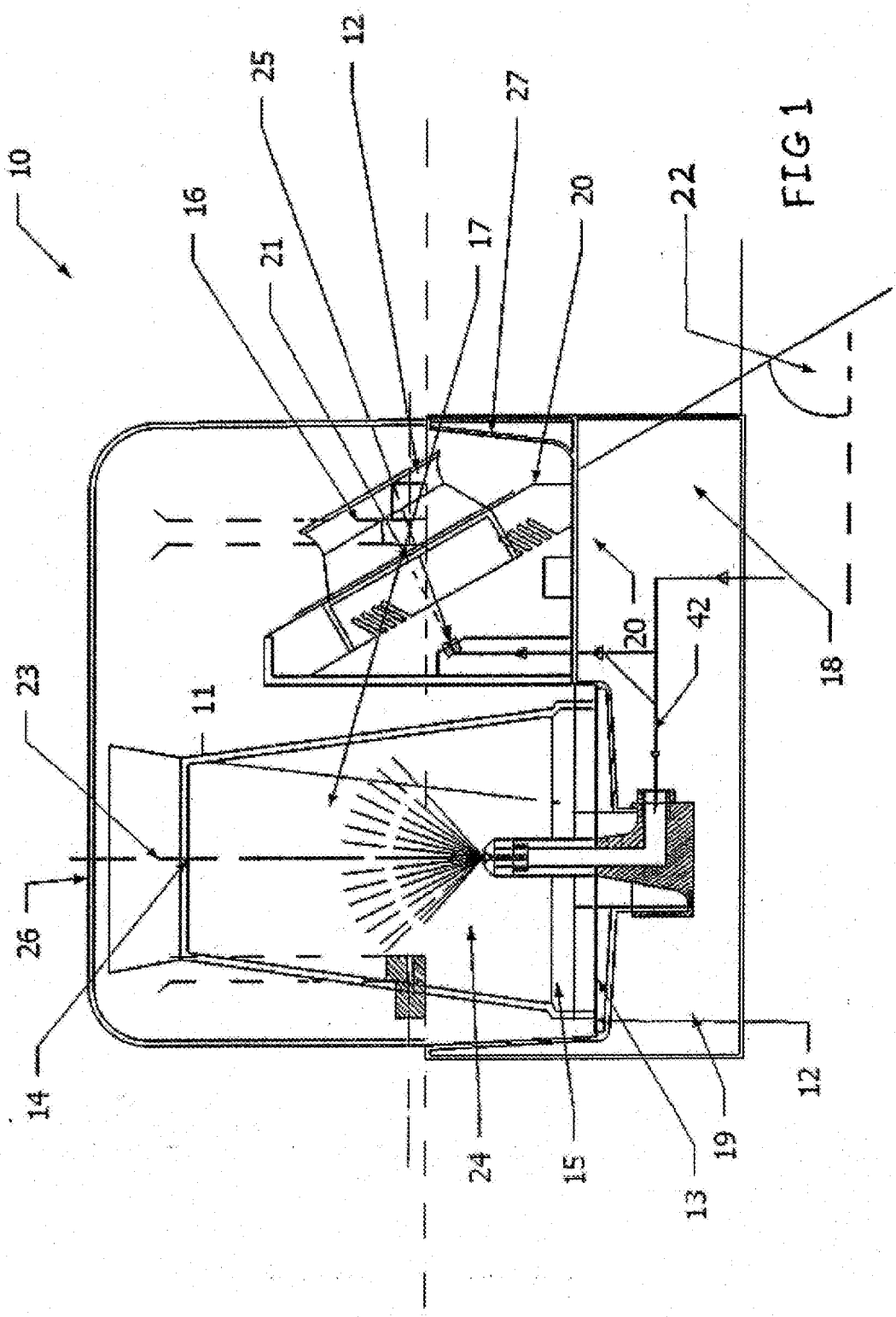

FIG 1

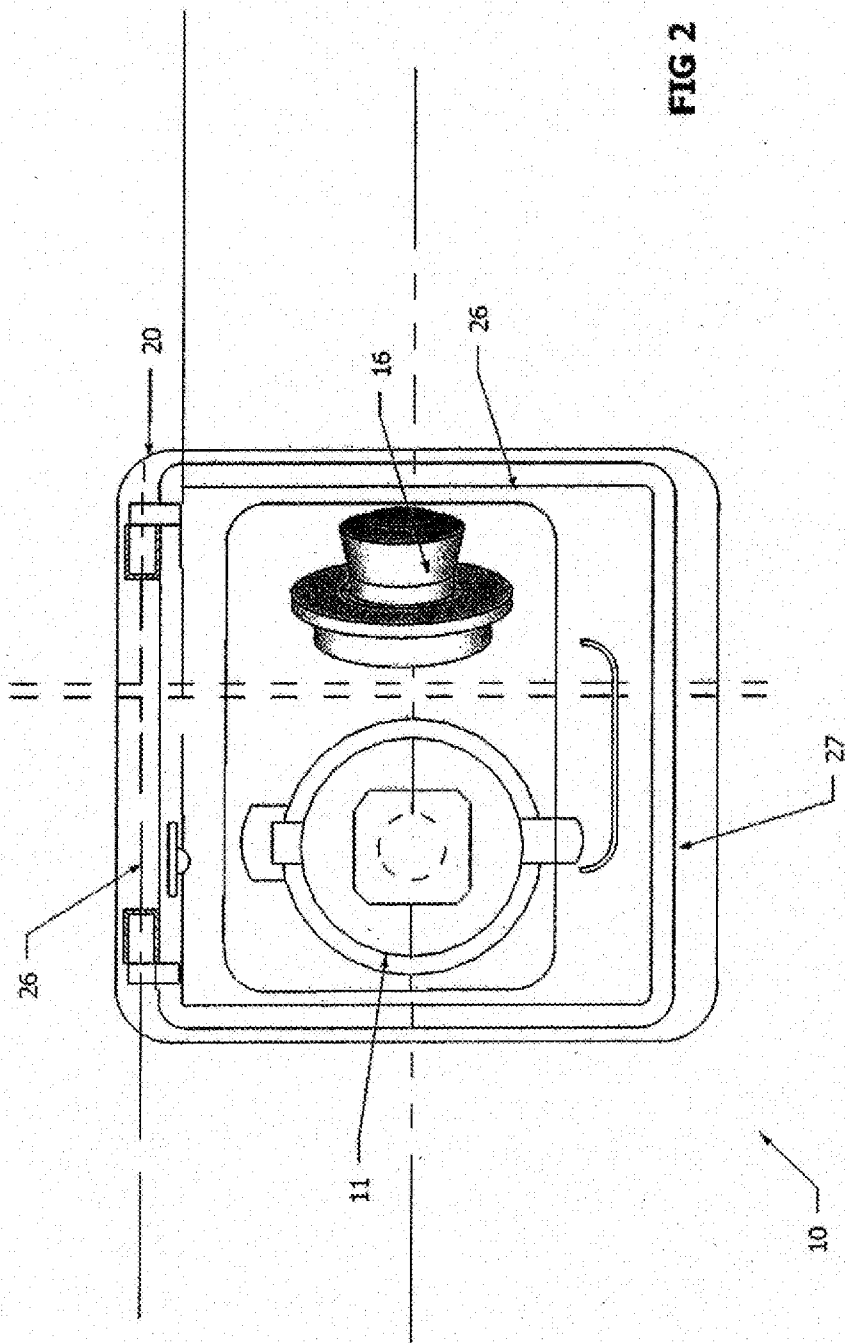
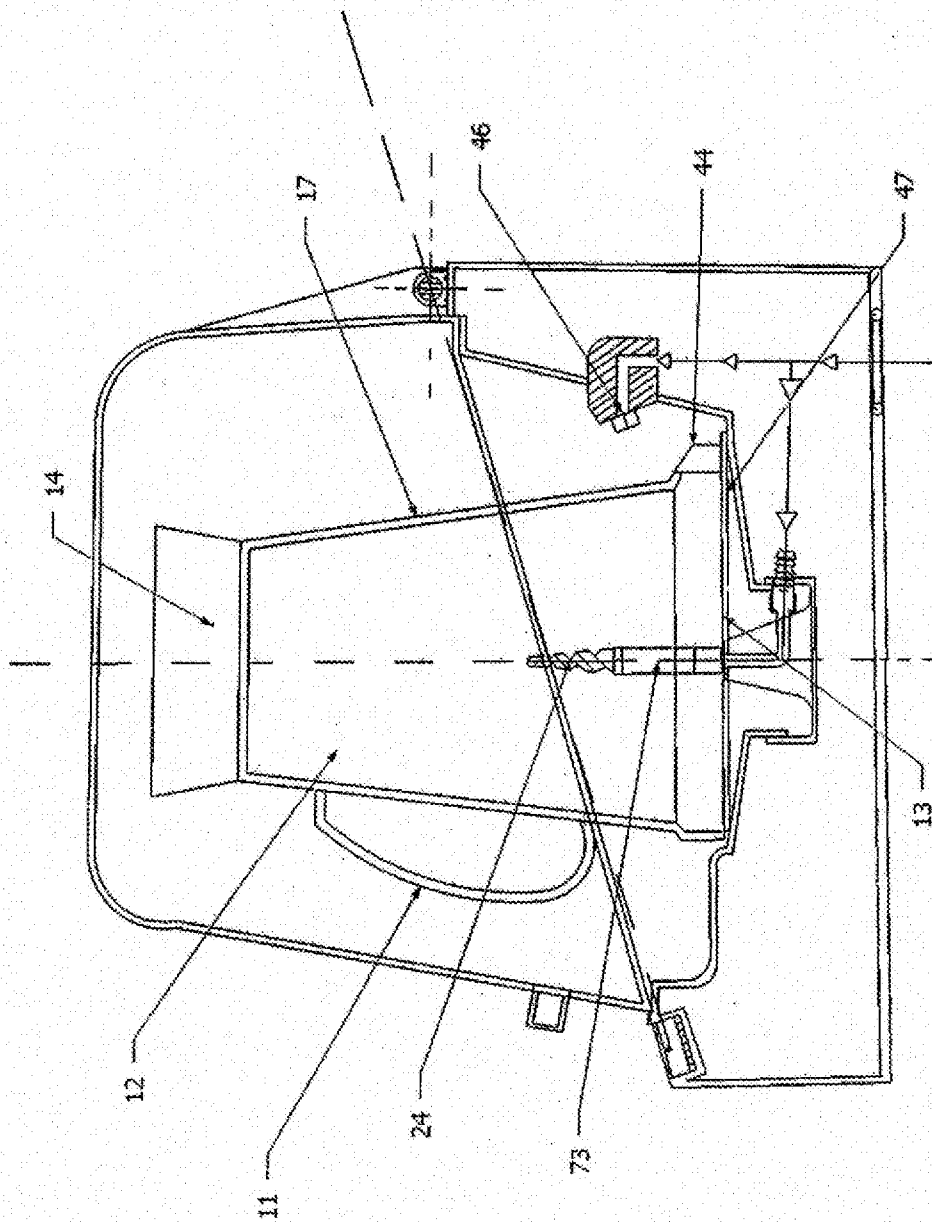
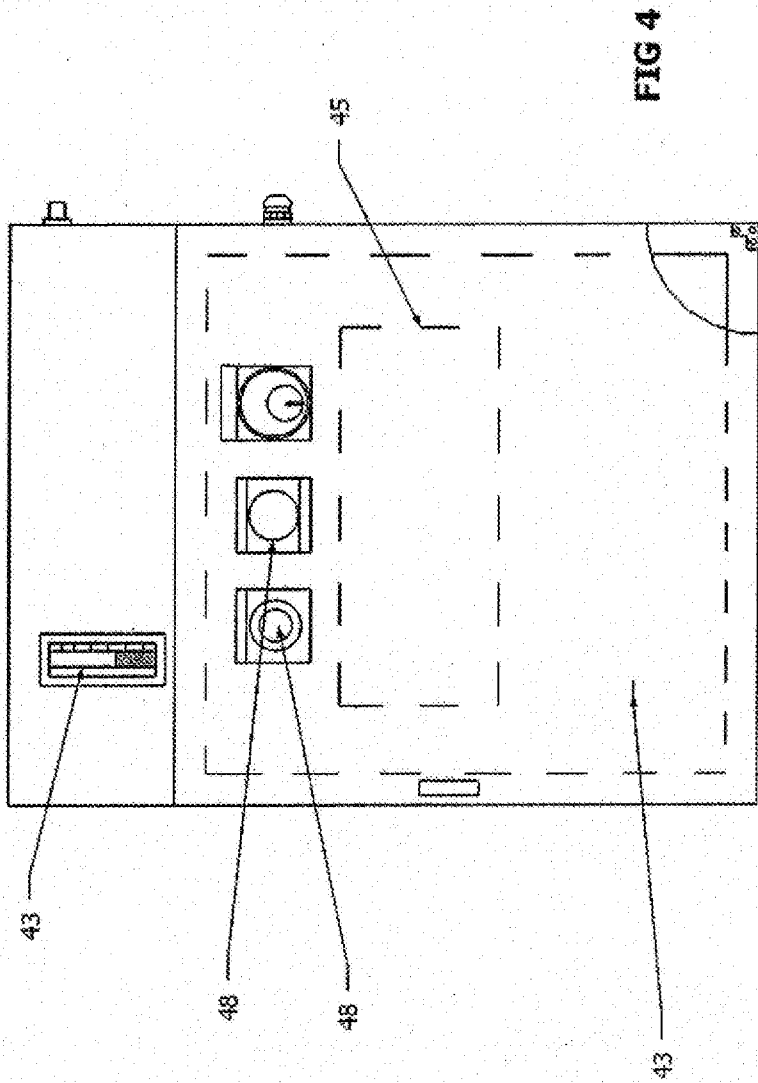

FIG 2





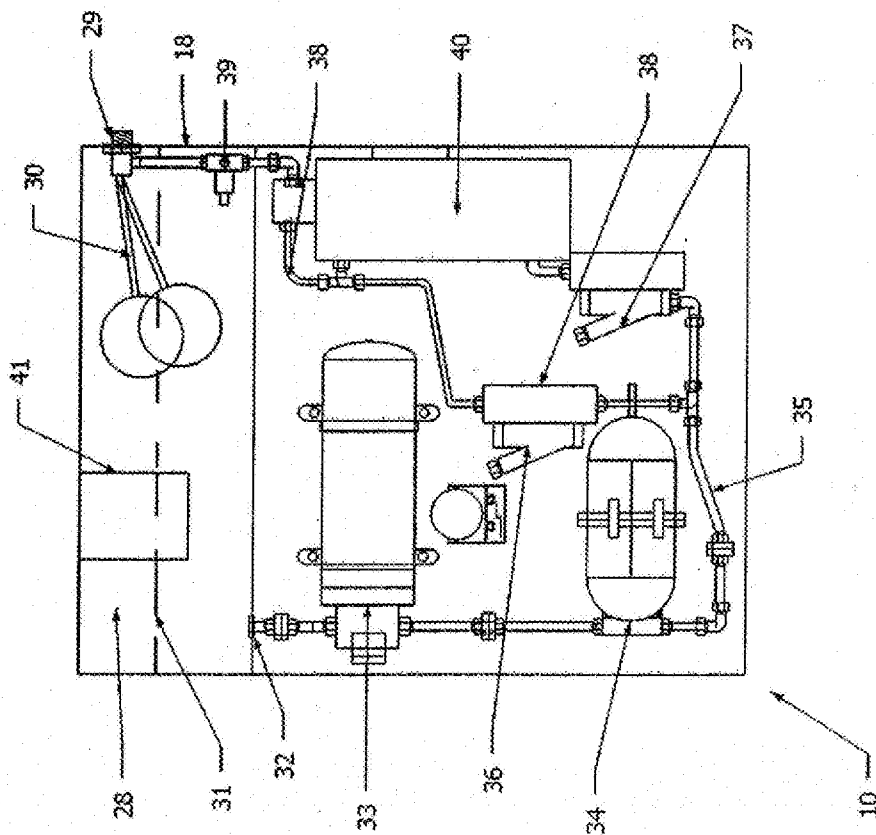
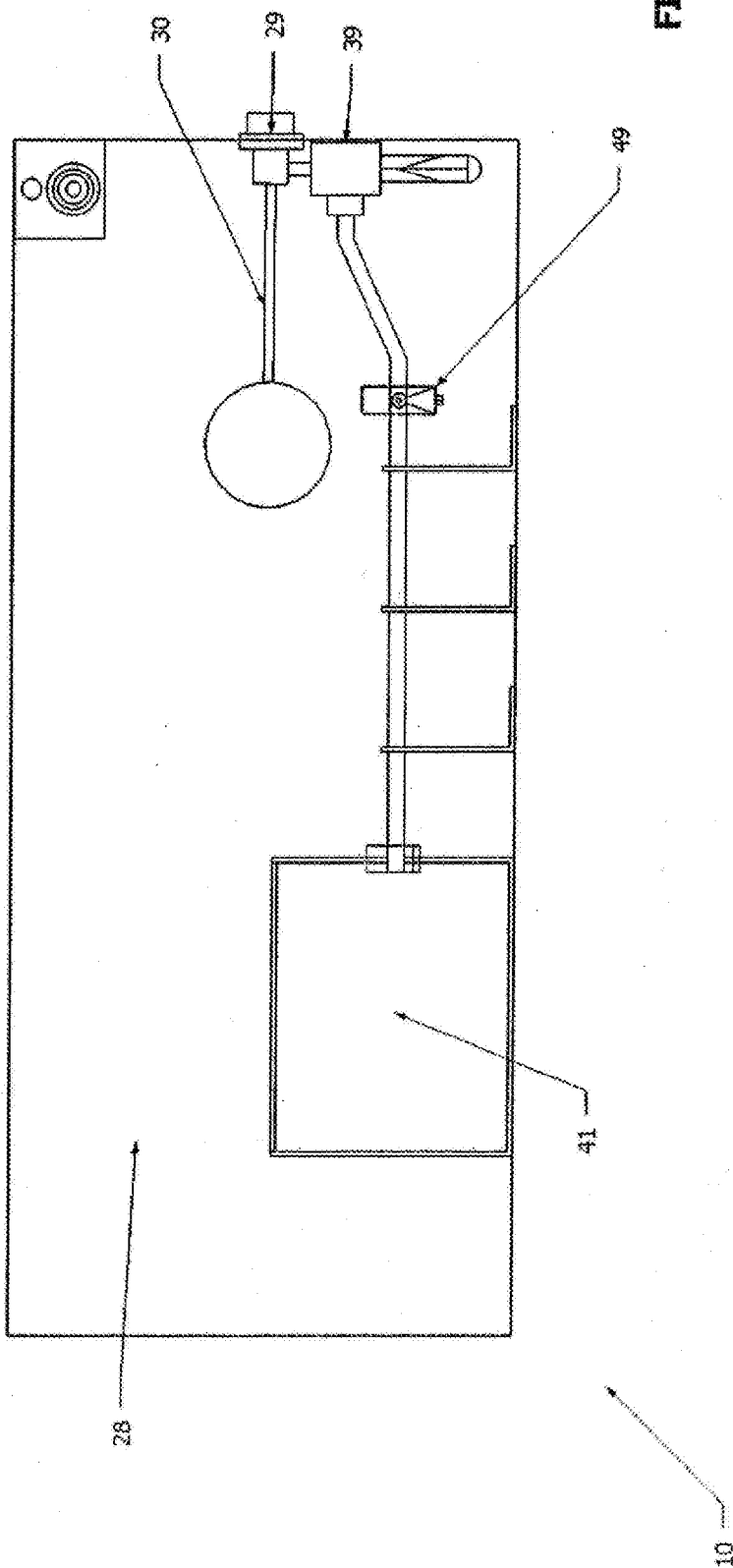
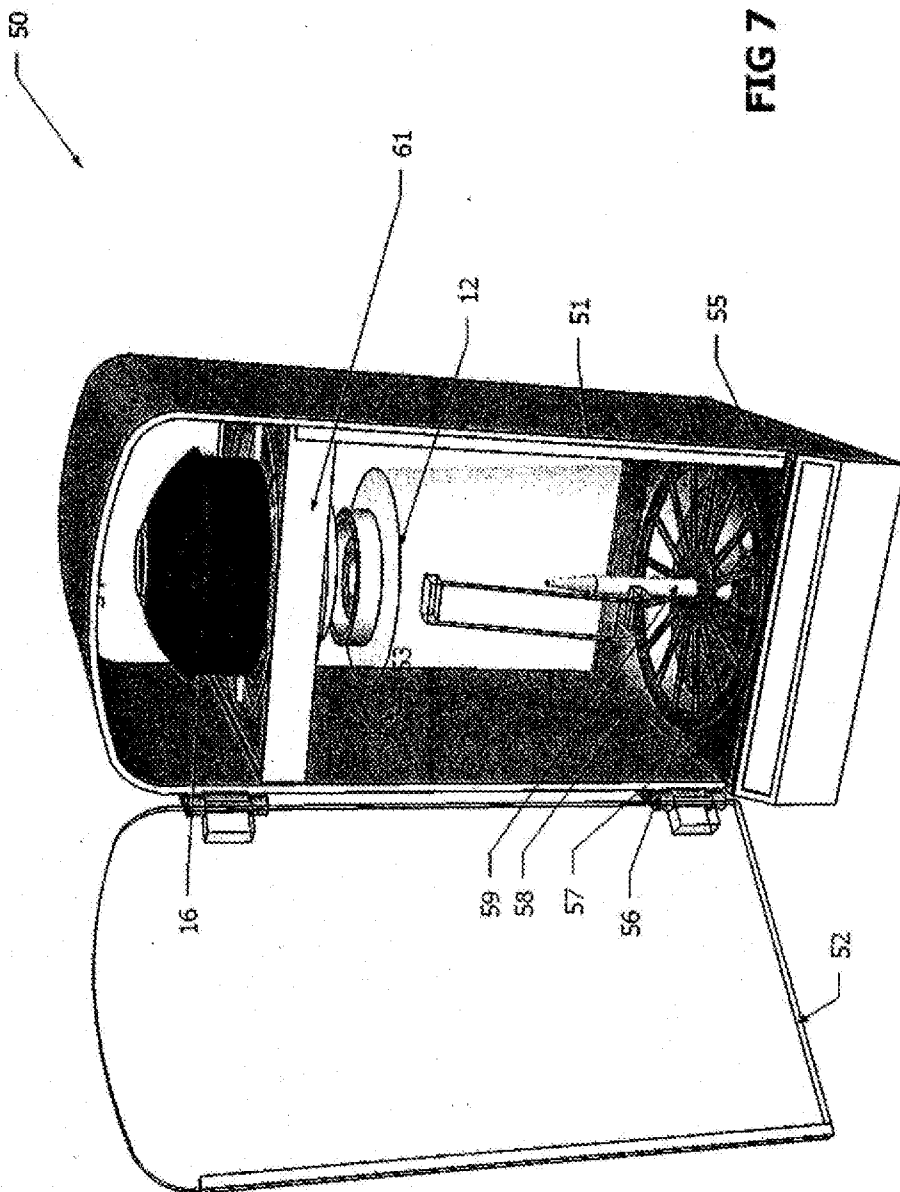

FIG 5





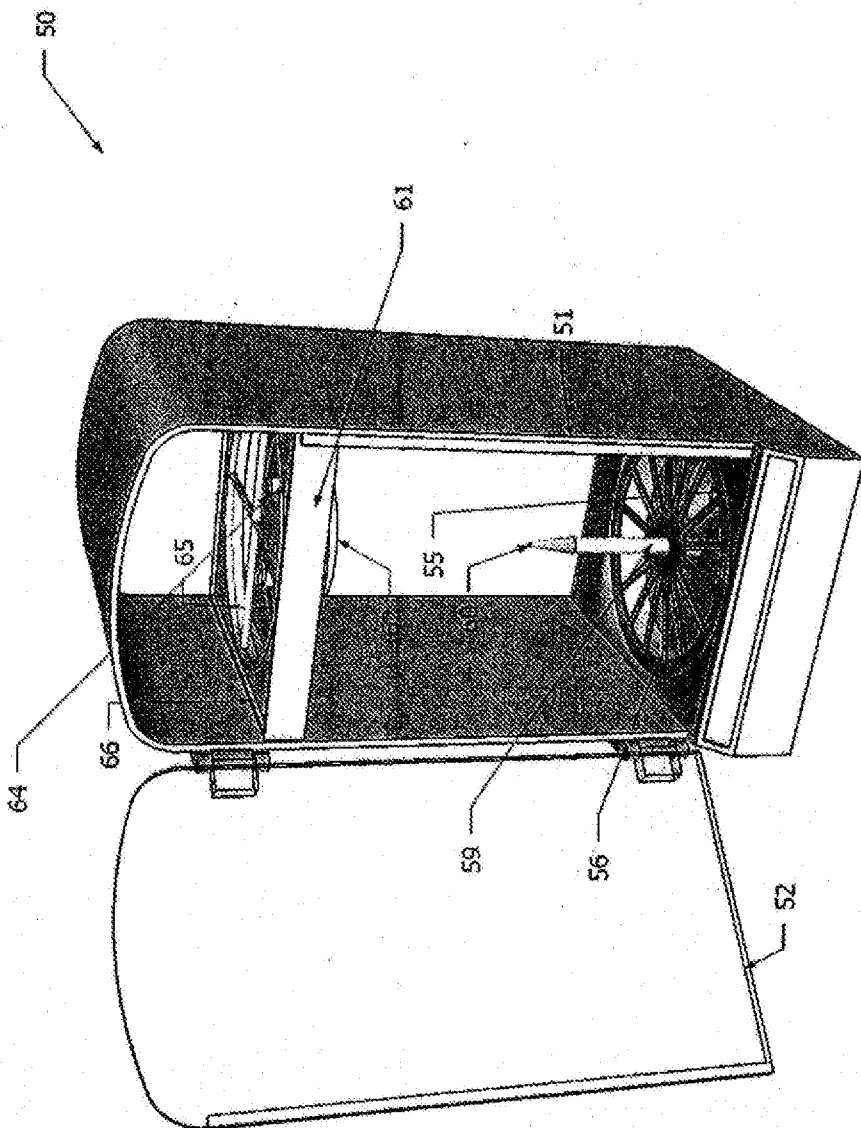

FIG 8

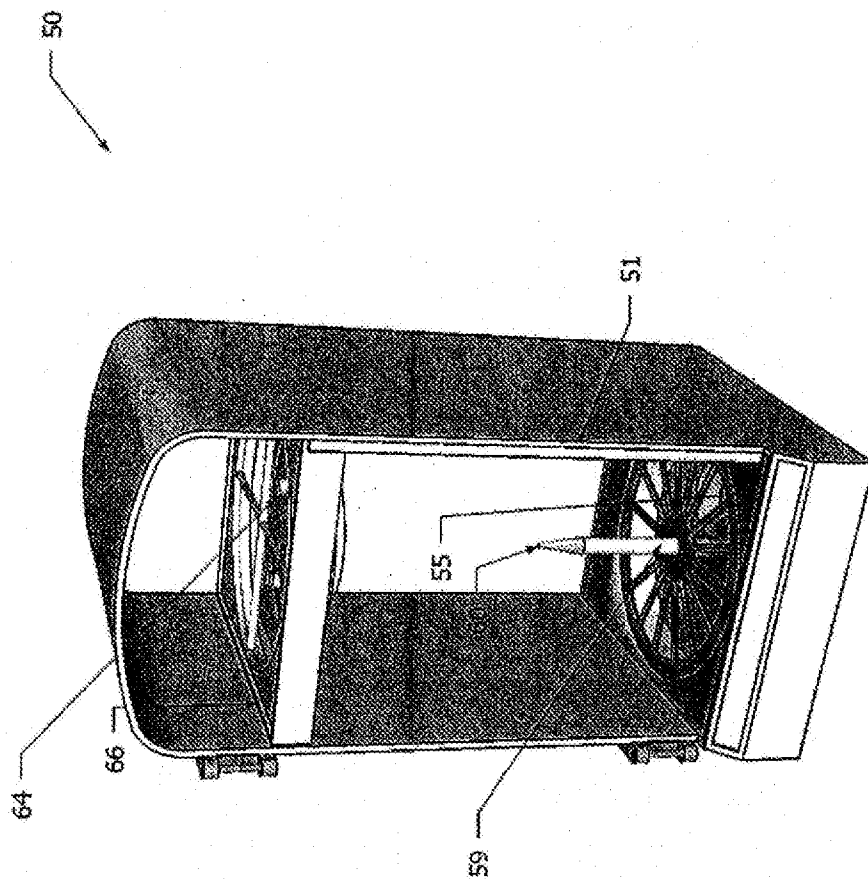

FIG 9

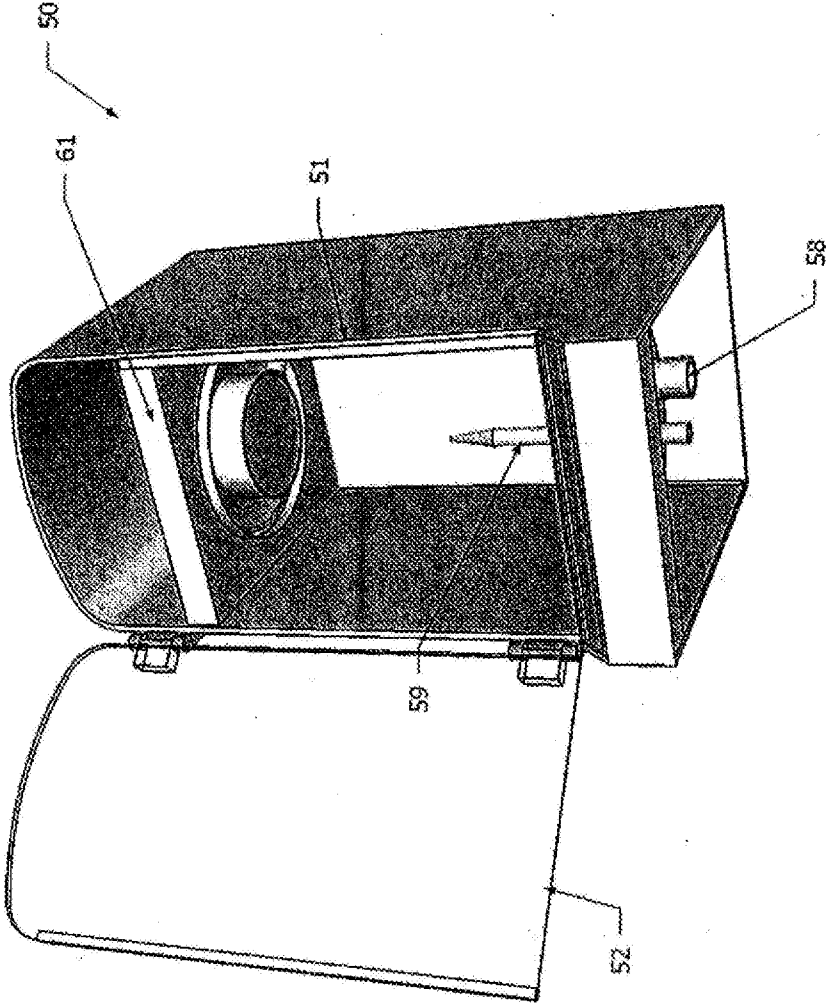

FIG 10

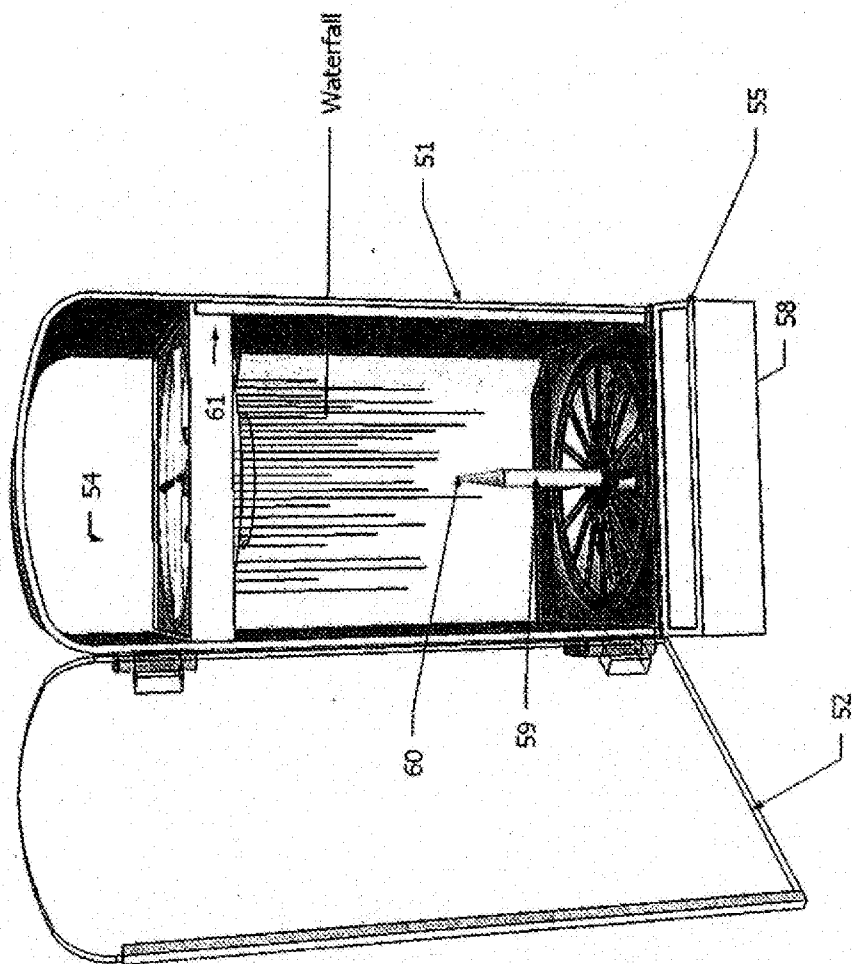

FIG 11

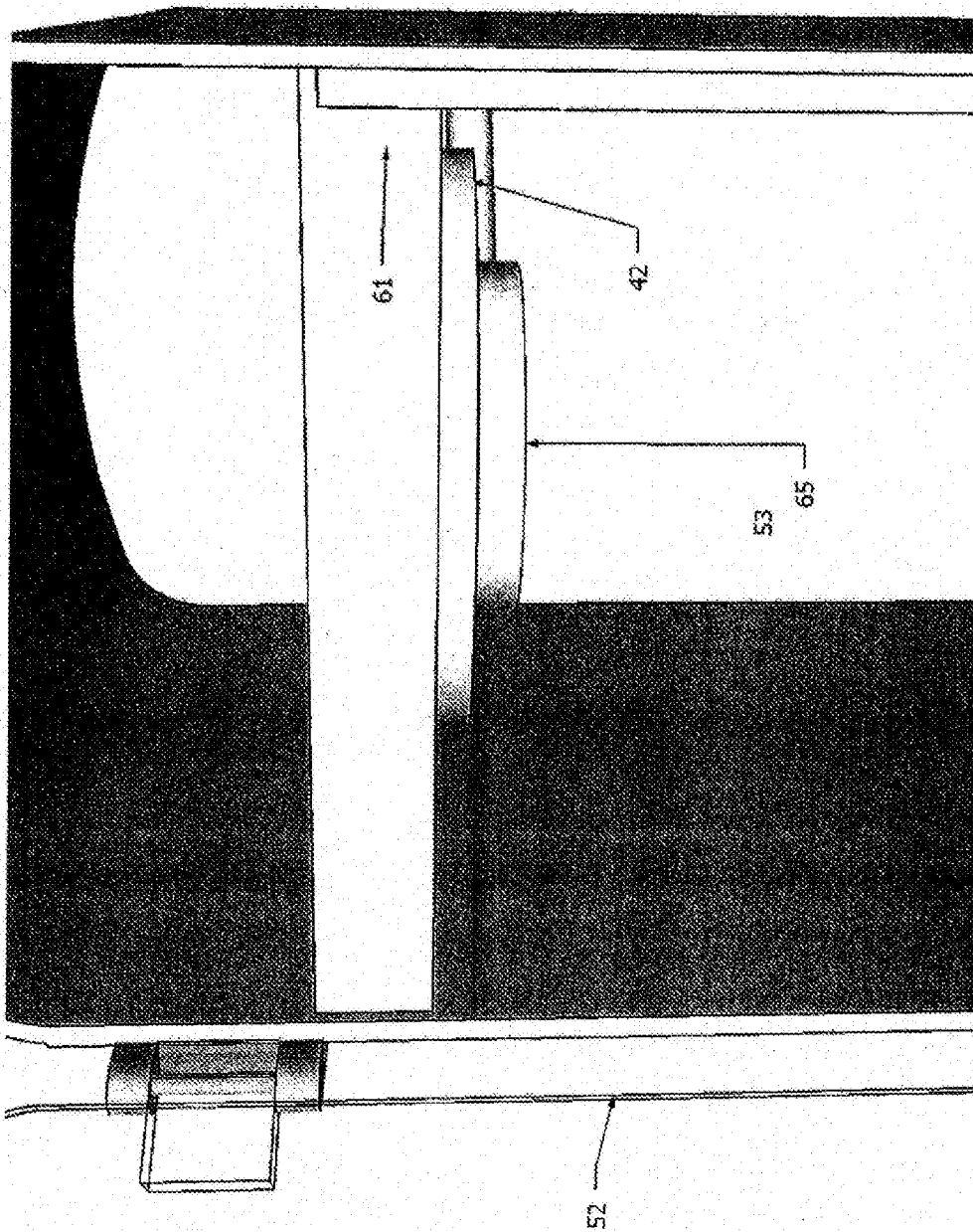
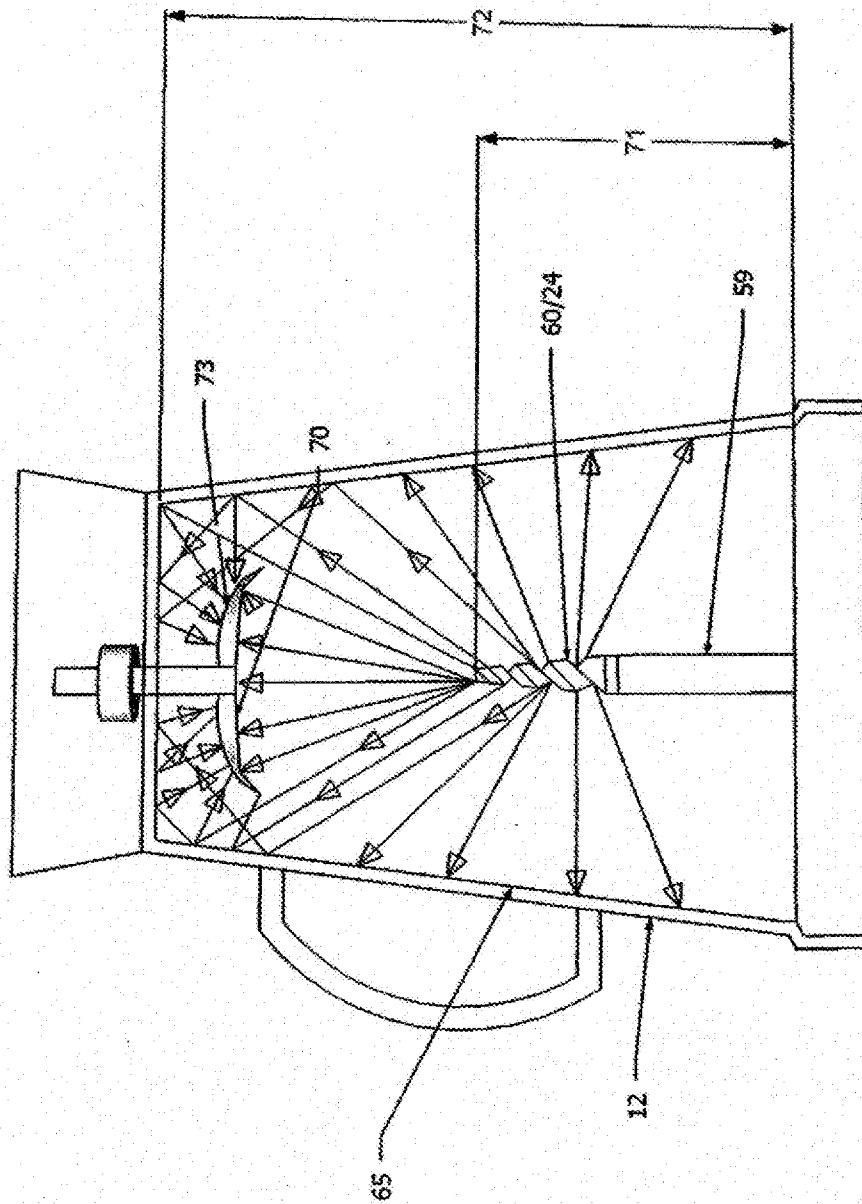

FIG 12



**A JUG WASHING MACHINE**

**FIELD**

[0001] The present invention relates to washers and more particular but not exclusively to washers that was jug, the jugs having an open top closed by a lid, with the jug having a base provided with blades, with the blades operable to mix liquid contained in the jug.

**BACKGROUND**

[0002] In the provision of mixed drinks, such as milkshakes and smoothies, a jug is employed. Typically the jug will have mounted in its base a blade or mixing assembly that is caused to rotate to mix the ingredients contained in the jug. The jug has an open top surrounded by a rim, with the rim being provided with a pouring lip. The open top is closed by a lid.

[0003] Typically the above discussed jugs are hand cleaned, with frequently the assistance of a flexible hose providing a spray head.

[0004] The above discussed methods of cleaning jugs are time consuming and therefore expensive when carried out in a commercial operation. A further disadvantage is that these methods may not totally clean the jug, especially areas surrounding the blades.

**OBJECT**

[0005] It is the object of the present invention to overcome or substantially ameliorate the above disadvantage.

**SUMMARY**

[0006] There is disclosed herein a washer to wash a hollow body having an interior extending between a bottom and an open top, with the open top closed by a lid, the lid having an inner surface to face said interior, and an outer surface, the washer including:

[0007] a base having a body receiving portion to support the body in an orientation that allows the body interior to drain, and a lid receiving portion to support the lid in an orientation that allows the lid to drain;

[0008] a first spray nozzle, the first nozzle being mounted on the base so as to direct a spray of cleaning liquid at said interior to clean the interior;

[0009] a second spray nozzle, the second nozzle being mounted on the base so as to direct a spray of said liquid at said inner surface;

[0010] a pump and ducting operable to deliver the liquid under pressure to the nozzles; and

[0011] a control assembly associated with the pump to govern operation of the pump, the control assembly being operable by a user.

[0012] Preferably, the base is configured to support the lid so that the lid is inclined in the horizontal by an acute angle to aid in drawing water from the lid.

[0013] Preferably, the washer includes a cover to enclose a space within which the body and lid are to be located.

[0014] Preferably, the hollow body has a rim with a pouring lip, and said base is adapted to engage said body to locate the pouring lip at a predetermined position, and said washer includes a third nozzle, the third nozzle receiving liquid under pressure to direct a spray at said predetermined location to clean said pouring lip.

[0015] Preferably, the base has at least one abutment surface to engage the lip to position the lip at said location.

[0016] Preferably, said washer includes a reservoir to receive a supply of said liquid, with the ducting extending from said reservoir to said pump to deliver the liquid to said pump.

[0017] Preferably, said liquid is water, and said reservoir receives water from a mains supply.

[0018] Preferably, said ducting includes a first duct through which the liquid passes to the nozzles, and a second duct communicating with the first duct, with the second duct being provided to deliver a cleaning and/or sterilizing agent to the first duct to be mixed with the liquid for delivery to the nozzles.

[0019] Preferably, the washer includes a venturi connecting the second duct with the first duct, with liquid passing through the first duct drawing the agent from the second duct.

[0020] Preferably, said washer includes an accumulator located between the pump and nozzles so that the liquid passes from the pump to the accumulator and then to the nozzles, with the accumulator storing said liquid under pressure, and a valve operable to release liquid from the accumulator for delivery to the nozzles.

[0021] Preferably, said base engages the body so that the body is inverted,

[0022] Preferably, the body has a longitudinal axis, with the base being adapted to engage the body so that the longitudinal axis is generally vertical oriented to thereby aid in draining said interior.

[0023] Preferably, the machine includes a cabinet having a first compartment and a second compartment, the first compartment being adapted to receive the hollow body in an inverted position, and the upper chamber being adapted to receive the lid.

[0024] Preferably, the second chamber is positioned above the first chamber so that water delivered to clean the lid flows through the first chamber to aid in cleaning external surfaces of the hollow body interior.

[0025] Preferably, the machine includes a valve stem, with the first spray nozzle being positioned at an upper portion of the valve stem so that the first nozzle is located at an upper portion of the hollow body.

[0026] Preferably, the valve stem has a height of 70 mm to 100 mm.

[0027] Preferably, the valve stem has a height of 80 mm to 90 mm.

[0028] Preferably, the stem has a height of about 85 mm.

[0029] Preferably, the machine includes further spray nozzles, the further spray nozzles cooperating with the second spray nozzle to clean said inner surface.

[0030] Preferably, all the nozzles are upwardly directed.

[0031] There is further disclosed herein a washer to wash a hollow body having an interior extending between a bottom and an open top, the washer including:

[0032] a base having a body receiving portion to support the body in an orientation that allows the body interior to drain;

[0033] a spray nozzle, the nozzle being mounted on the base so as to direct a spray of cleaning liquid at said interior to clean the interior;

[0034] a reservoir for said liquid;

[0035] a pump operable to provide liquid under pressure for delivery to the nozzle;

[0036] a first duct joining the pump and reservoir to provide for the delivery of liquid to the pump;

- [0037] a second duct extending to the nozzle and via which the pump delivers liquid to the nozzle;
- [0038] a fourth duct, the fourth duct providing for the delivery of an agent to the liquid for delivery to the pump; and
- [0039] a control assembly associated with the pump to govern operation of the pump, the control being operable by a user.
- [0040] Preferably, the reservoir is a first reservoir, and the machine includes a second reservoir, the second reservoir receiving said agent, with the fourth duct providing for the delivery of the agent from the second reservoir to the first reservoir.
- [0041] Preferably, the machine includes a venturi via which the liquid is delivered to the first reservoir, with the fourth duct being operatively associated with the venturi to deliver the agent to the venturi to be mixed with water being delivered to the first reservoir.
- [0042] Preferably, the machine includes an accumulator with the pump delivering liquid under pressure to be stored in the accumulator, with the accumulator delivering liquid under pressure to the nozzle.
- [0043] There is still further disclosed herein a machine to wash a hollow body having an interior extending between a bottom and an open top, the machine including:
- [0044] a base having a body receiving portion to support the body in an orientation that allows the body interior to drain;
- [0045] a spray nozzle, the nozzle being mounted on the base so as to direct a spray of cleaning liquid at said interior to clean the interior;
- [0046] a reservoir to receive said liquid;
- [0047] a pump connected to the reservoir to receive liquid from the reservoir and to provide said liquid under pressure;
- [0048] an accumulator connected to the pump to receive the liquid under pressure to store the liquid under pressure; and
- [0049] ducting extending from the accumulator to the nozzle to deliver the liquid under pressure to the nozzle.
- [0050] Preferably, said machine includes a valve between the accumulator and the nozzle, the valve being operable to release the liquid under pressure for delivery from the accumulator to the nozzle.

#### BRIEF DESCRIPTION OF DRAWINGS

- [0051] Preferred forms of the present invention will now be described by way of example with reference to the accompanying drawings wherein:
- [0052] FIG. 1 is a schematic parts sectioned side elevation of a jug washing machine;
- [0053] FIG. 2 is a schematic top plan view of the machine of FIG. 1;
- [0054] FIG. 3 is a further schematic sectioned side elevation of the machine of FIG. 1;
- [0055] FIG. 4 is a schematic side elevation of the machine of FIG. 1;
- [0056] FIG. 5 is a schematic side elevation of the interior of the machine of FIG. 1;
- [0057] FIG. 6 is a top plan view of the interior of the machine of FIG. 1;
- [0058] FIG. 7 is a schematic parts isometric view of a modification of the machine of FIG. 1; and

- [0059] FIGS. 8 to 12 are schematic isometric views of the machine of FIG. 7; and
- [0060] FIG. 13 is a schematic section side elevation of portion of the machine of FIGS. 1 and 7.

#### DESCRIPTION OF EMBODIMENTS

- [0061] In FIGS. 1 to 6 of the accompanying drawings there is schematically depicted a jug washing machine 10. The machine 10 is adapted to receive a jug 11, the jug 11 having a hollow body 12 terminating at its upper end with a rim 13. Spaced from the rim 13 is a jug bottom 14. Typically there would be mounted in the bottom 14 a stirring/mixing assembly, such as a plurality of rotatably driven blades (not illustrated). The open top 15, surrounded by the rim 13, is closed by means of a lid 16. The body 12 and lid 16 enclose an interior 17 that receives liquids and/or solids to be mixed by the jug 11, upon operation of the abovementioned stirring assembly. The lid 16 has an inner surface 65 to face the interior 17, and an outer surface.
- [0062] The machine 10 includes a base 18 that provides a body receiving portion 19 upon which the body 12 rest in a generally inverted position so the interior 17 drains. The base 18 includes a second receiving portion 20 that receives the lid 16 so that the inner surface 21 of the lid 16 projects downwardly so as to aid draining of the lid 16. Preferably the lid 16 is inclined to the horizontal by an acute angle 22 to aid in draining water from the lid 16.
- [0063] Preferably, the jug 11 has a longitudinal axis 23 that is generally vertically oriented. However it should be appreciated that the axis 23 may be inclined by an acute angle to the horizontal, that is the body 12 merely needs to be oriented so that the interior 17 drains.
- [0064] Fixed to the base 18 at its portion 19 is a first nozzle 24 that is fixed to the upper portion of a stem 73. Fixed to the base 18 at the portion 20 is a second nozzle 25. The nozzle 24 cleans the interior 17 and the nozzle 25 cleans the surface 21. The nozzles 24 and 25 are upwardly directed so that water spray therefrom is upwardly directed.
- [0065] Pivotaly attached to the base 20 is a cover 26, that is pivotaly attached to the base 18 for angular movement about a generally horizontal axis 45, so that the cover 26 is movable between a covered position (as shown in FIG. 1) and an open position. In the covered position, the cover 26 encloses the body 12 and lid 16, while in the open position the body 12 and lid 16 may be inserted and/or removed.
- [0066] Preferably, the cover 26 engages the base 18 to retain any liquid used to clean the jug 11. As best seen in FIG. 1, the base 18 has a flange 27 that is generally upwardly oriented and surrounds the lower portion of the cover 26 to ensure any cleaning liquid does not escape.
- [0067] Preferably, the cover 26 has a handle 27.
- [0068] It should be appreciated FIG. 1 only illustrates the upper portion of the base 18. There remainder of the base 18 is illustrated in FIG. 5. The base 18 encloses a reservoir 28 that receives water via a water inlet 29 that would communicate with a mains pressure supply. Typically a float valve 30 provides the delivery of water to the interior of the reservoir 28 so as to maintain a water level 31.
- [0069] The reservoir 28 has an outlet 32, the outlet 32 is connected to a pump 33, with the pump 33 in turn connected to an accumulator 34. Ducting connects the reservoir 28 with the pump 33, as well as connecting the pump 33 with the accumulator 34. The ducting 35 extends from the accumulator 34 to valves 36 and 37. The valve 36 is connected to

ducting 38 that extends to a venturi 39. The valves 36 and 37 are electrically operated by means of a control 38. The valve 37 is operable to deliver water to a heater 40, with the heater 40 also connected to the ducting 38. Accordingly by operation of the valves 36 and 37, cold or hot water can be delivered to the ducting 38. As an alternative cold and hot water may be mixed so that water of a desired temperature is delivered to the ducting 38.

[0070] The venturi 39 receives water from the ducting 38.

[0071] The venturi 39 is also connected to a further reservoir 41 that receives a cleaning and/or sterilizing agent in liquid form. Accordingly as water passes from the ducting 38 through the venturi 39, the liquid stored in the reservoir 41 is drawn into the venturi to be mixed with the water in a desired proportion. Ducting 42 extends from the venturi 39 to the nozzles 24 and 25.

[0072] Preferably, the machine 10 may further include valves that are operable to deliver the water under pressure to the nozzles 24 and 25 simultaneously, or in sequence. If in sequence, one nozzle 24 or 25 would receive the water under pressure followed by the second nozzle 24, 25.

[0073] In a further preferred form, the machine 10 includes a detector 49 that is operable to identify the agent coming from the reservoir 41. If the agent is an undesirable agent, that is an agent which does not clean and/or sterilize, then the detector 49 communicates with processor 45 so that the machine 10 is held inoperative until the error is corrected.

[0074] Preferably, the reservoir 28 has a liquid level indicator 43.

[0075] It is also preferable the machine 10 has a control panel 43 with user operable buttons or switches to operate the valves 36 and 37. The switches 48 would include a processor 45 that would be programmed to control the temperature of water delivered to the ducting 38 as well as the duration of operation of the pump 33, and operation of the valves 36 and 37 so that the nozzles 24 and 25 are operated for a desired period.

[0076] Preferably, the jug 11 has a pouring lip 44 as part of the rim 13. Preferably, the portion 19 receives the jug 11 so that the pouring lip 44 is located at a predetermined position. Preferably, the portion 19 has an abutment surface or surfaces 47 to engage the lip 44 to position the lip 44 and said position.

[0077] Mounted on the base 18 is a third nozzle 46 that directs a stream (spray) at the pouring lip 44 to cleaning the pouring lip 44. The nozzle 46 is connected to the ducting 42 so as to receive water under pressure therefrom.

[0078] In FIGS. 7 to 12, there is schematically depicted a jug washing machine 50 that is a modification of the machine 10 of FIGS. 1 to 6.

[0079] The machine 50 is adapted to receive the jug 11, that is the hollow body 12 and the lid 16.

[0080] The machine 50 includes a cabinet (base) 51 having a door 52 that is operable to close the cabinet 51 so that the cabinet 51 and door 52 enclose a lower chamber 53 and an upper chamber 54. The lower chamber 53 receives the jug body 12 in an inverted orientation while the upper chamber 54 receives the lid 16 with the surface 70 downwardly facing.

[0081] The cabinet 51 includes a floor 55 providing a drain cavity 56. A grid 57 overlays the cavity 56 to provide for water used to wash the body 12 to be delivered to a drain 58. The drain 58 extends from a lower portion of the cavity 56. Extending upwardly through a central portion of the floor 55 is a nozzle stem 59 terminating at its upper end with a nozzle 60. The stem 59 locates the nozzle 60 at an upper portion

within the interior 17 of the body 12. The stem 59 is connected to the duct 42 as previously described with reference to FIGS. 5 and 6.

[0082] The cabinet 51 also provides an upper floor 61 (base) having a drain cavity 62. The floor 61 provides a plate 63 within which there is mounted a plurality of nozzles 64 which are also connected to the duct 42. Surrounding the plate 63 is an annular aperture 65 that provides for the drainage of water to the chamber 53 to flow over the exterior surfaces of the body 12 to aid in cleaning the body 12.

[0083] Preferably, the plate 63 is hollow so as to receive the liquid under pressure from the duct 42, with the nozzles 64 communicating with the interior of the plate 63.

[0084] In a further preferred form, the machine 50 of FIGS. 7 to 12 may also be provided with surfaces such as the surfaces 47, to engage the lip 44, of the embodiment of FIG. 3, and a nozzle 46 to clean the jug lip 44.

[0085] As described with the previous embodiment, in the embodiment of FIGS. 7 to 12, the machine 50 may be provided with the reservoirs 28 and 41, pump 33 and accumulator 34 as well as ducting and valving as described with reference to FIGS. 1 to 6 so as to upgrade in the same manner as the embodiment of FIGS. 1 to 6.

[0086] Support members 66 are located above the cavity 62 provide a support upon which the lid 16 rests. The nozzles 64 are directed upwardly so as to clean the inner surface 21 of the lid 16. In this embodiment, the chamber 54 (and therefore lid 16) is located above the chamber 53 (and therefore the body 12).

[0087] Preferably the cabinet 51 has nozzles in the top of the chamber 54 to clean the upper surface of the lid 16.

[0088] The reservoir 41 may be replaced with a cartridge system, that is the agent to be delivered to the water may be contained in a cartridge to be coupled to the duct extending to the venturi 39. In a further modification, the detector 49 may be replaced with another mechanism operatively associated with the cartridge to detect when the cartridge is empty. The cartridge and machine 10 could be configured to prevent reuse of the cartridge (or use of an unauthorised cartridge). This would inhibit use of an unacceptable agent.

[0089] Preferably, the nozzles 24, 25, 46, 60 and 64 receive the water (with cleaning and/or sterilizing agent) under pressure so as to produce a spray to clean the jug 11. Preferably, the nozzles 24 and 60 are nozzles as described in patent specification EP1486257. With reference to FIG. 13, the nozzles 24 and 60 cause the spray to swirl about the interior side wall surface 65 of the body 12, engage the interior surface 69 of the body base to thereby be directed at the blades 70, especially the surface of the blades 70 facing the interior surface 69 of the body base. Additionally the areas surrounding the central mounting 73 for the blades 70 at the base is cleaned.

[0090] Preferably, the stem 59, 73 has a height 71 that is about 20% to 50% of the height 72, more preferably about 30% to 40% of the height 72 of the surface 69.

[0091] Preferably, the stem 53, 73 has a height 71 of 70 mm to 100 mm, more preferably the height 71 is 80 mm to 90 mm, most preferably about 85 mm. The height 72 is about 240 mm to 320 mm.

[0092] The above described preferred embodiments provide particular advantages in respect of cleaning jugs 11 used to provide mixed drinks. In particular delivery of a cleaning and/or sterilizing agent, mixed with water, under pressure to clean the area adjacent the blades 70 of the jug 11. The

nozzles **24** and **60** provide a conical spray stream, as well as stream that rotates about the rotation axis of the blades. Both streams are directed at the surface **69** to ensure cleaning of the blades **70** and their mounting. The spray streams retain a volume of water adjacent the surface **69**. Upon the spray action ceasing the retained volume of water flows down the surface **65** to further aid cleaning.

**1.** A washer to wash a hollow body having an interior extending between a bottom and an open top, with the open top closed by a lid, the lid having an inner surface to face said interior, and an outer surface, the washer including:

- a base having a body receiving portion to support the body in an orientation that allows the body interior to drain, and a lid receiving portion to support the lid in an orientation that allows the lid to drain;
- a first spray nozzle, the first nozzle being mounted on the base so as to direct a spray of cleaning liquid at said interior to clean the interior;
- a second spray nozzle, the second nozzle being mounted on the base so as to direct a spray of said liquid at said inner surface;
- a pump and ducting operable to deliver the liquid under pressure to the nozzles; and
- a control assembly associated with the pump to govern operation of the pump, the control assembly being operable by a user.

**2.** The washer of claim **1**, wherein the base is configured to support the lid so that the lid is inclined in the horizontal by an acute angle to aid in draining water from the lid.

**3.** The washer of claim **1**, wherein the washer includes a cover to enclose a space within which the body and lid are to be located.

**4.** The washer of claim **1**, wherein the hollow body has a rim with a pouring lip, and said base is adapted to engage said body to locate the pouring lip at a predetermined position, and said washer includes a third nozzle, the third nozzle receiving liquid under pressure to direct a spray at said predetermined location to clean said pouring lip.

**5.** The washer of claim **4**, wherein the base has at least one abutment surface to engage the lip to position the lip at said location.

**6.** The washer of claim **1**, wherein said washer includes a reservoir to receive a supply of said liquid, with the ducting extending from said reservoir to said pump to deliver the liquid to said pump.

**7.** (canceled)

**8.** The washer of claim **1**, wherein said ducting includes a first duct through which the liquid passes to the nozzles, and a second duct communicating with the first duct, with the second duct being provided to deliver a cleaning and/or sterilizing agent to the first duct to be mixed with the liquid for delivery to the nozzles.

**9.** The washer of claim **8**, wherein the washer includes a venturi connecting the second duct with the first duct, with liquid passing through the first duct drawing the agent from the second duct.

**10.** The washer of claim **1**, wherein said washer includes an accumulator located between the pump and nozzles so that the liquid passes from the pump to the accumulator and then to the nozzles, with the accumulator storing said liquid under pressure, and a valve operable to release liquid from the accumulator for delivery to the nozzles.

**11.** The washer of claim **1**, wherein said base engages the body so that the body is inverted.

**12.** The washer of claim **1**, wherein the body has a longitudinal axis, with the base being adapted to engage the body so that the longitudinal axis is generally vertical oriented to thereby aid in draining said interior, and the machine includes a cabinet having a first compartment and a second compartment, the first compartment being adapted to receive the hollow body in an inverted position, and the upper chamber being adapted to receive the lid with the second chamber is positioned above the first chamber so that water delivered to clean the lid flows through the first chamber to aid in cleaning external surfaces of the hollow body interior.

**13.-14.** (canceled)

**15.** The washer of claim **1**, wherein the machine includes a valve stem, with the first spray nozzle being positioned at an upper portion of the valve stem so that the first nozzle is located at an upper portion of the hollow body.

**16.** The washer of claim **15**, wherein the valve stem has a height of 70 mm to 100 mm.

**17.-18.** (canceled)

**19.** The washer of claim **1**, wherein the washer includes further spray nozzles, the further spray nozzles cooperating with the second spray nozzle to clean said inner surface.

**20.** (canceled)

**21.** A washer to wash a hollow body having an interior extending between a bottom and an open top, the washer including:

- a base having a body receiving portion to support the body in an orientation that allows the body interior to drain;
- a spray nozzle, the nozzle being mounted on the base so as to direct a spray of cleaning liquid at said interior to clean the interior;
- a reservoir for said liquid;
- a pump operable to provide liquid under pressure for delivery to the nozzle;
- a first duct joining the pump and reservoir to provide for the delivery of liquid to the pump;
- a second duct extending to the nozzle and via which the pump delivers liquid to the nozzle;
- a fourth duct, the fourth duct providing for the delivery of an agent to the liquid for delivery to the pump; and
- a control assembly associated with the pump to govern operation of the pump, the control being operable by a user.

**22.** The washer of claim **21**, wherein the reservoir is a first reservoir, and the machine includes a second reservoir, the second reservoir receiving said agent, with the fourth duct providing for the delivery of the agent from the second reservoir to the first reservoir.

**23.** The washer of claim **21**, further including a venturi via which the liquid is delivered to the first reservoir, with the fourth duct being operatively associated with the venturi to deliver the agent to the venturi to be mixed with water being delivered to the first reservoir.

**24.** The washer of claim **21**, further includes an accumulator with the pump delivering liquid under pressure to be stored in the accumulator, with the accumulator delivering liquid under pressure to the nozzle.

**25.** A washer to wash a hollow body having an interior extending between a bottom and an open top, the machine including:

- a base having a body receiving portion to support the body in an orientation that allows the body interior to drain;

a spray nozzle, the nozzle being mounted on the base so as to direct a spray of cleaning liquid at said interior to clean the interior;

a reservoir to receive said liquid;

a pump connected to the reservoir to receive liquid from the reservoir and to provide said liquid under pressure;

an accumulator connected to the pump to receive the liquid under pressure to store the liquid under pressure; and ducting extending from the accumulator to the nozzle to deliver the liquid under pressure to the nozzle.

**26.** The washer of claim **24**, further including a valve between the accumulator and the nozzle, the valve being operable to release the liquid under pressure for delivery from the accumulator to the nozzle.

\* \* \* \* \*