



US007299961B2

(12) **United States Patent**
Stavig, Jr. et al.

(10) **Patent No.:** **US 7,299,961 B2**
(45) **Date of Patent:** **Nov. 27, 2007**

(54) **DEVICE FOR CONTROLLED DEPTH RIVETING**

(75) Inventors: **Paul N. Stavig, Jr.**, Puyallup, WA (US); **Sujith N. Mally**, Bellevue, WA (US); **Jeffrey W. Hamilton**, Renton, WA (US)

(73) Assignee: **The Boeing Company**, Chicago, IL (US)

(*) Notice: Subject to any disclaimer, the term of this patent is extended or adjusted under 35 U.S.C. 154(b) by 0 days.

2,409,377 A	10/1946	Miller	
4,637,539 A *	1/1987	Turcott et al.	227/156
4,821,937 A *	4/1989	Rafferty	227/8
5,074,453 A *	12/1991	Tachihara et al.	227/130
5,096,342 A	3/1992	Blankenship et al.	
5,219,110 A	6/1993	Mukoyama	
5,385,286 A *	1/1995	Johnson, Jr.	227/8
6,581,815 B1 *	6/2003	Ho et al.	227/142
6,695,192 B1 *	2/2004	Kwok	227/8
6,763,992 B2 *	7/2004	Hirai	227/142
7,032,797 B2 *	4/2006	Liao	227/142
2003/0080172 A1	5/2003	Hirai	
2004/0035906 A1 *	2/2004	Tucker et al.	227/142

(21) Appl. No.: **11/366,190**

(22) Filed: **Mar. 2, 2006**

(65) **Prior Publication Data**

US 2007/0205245 A1 Sep. 6, 2007

(51) **Int. Cl.**
B25C 1/08 (2006.01)

(52) **U.S. Cl.** **227/142; 227/107; 227/110; 227/147**

(58) **Field of Classification Search** **227/107, 227/110, 142, 147**

See application file for complete search history.

(56) **References Cited**

U.S. PATENT DOCUMENTS

2,359,859 A 10/1944 Jarvis

* cited by examiner

Primary Examiner—Brian D. Nash
(74) *Attorney, Agent, or Firm*—Jeffrey D. Moy; Weiss & Moy, P.C.

(57) **ABSTRACT**

An adjustable depth control device for a fastener driving tool has an attachment member which is used to couple the adjustable depth control device to the fastener driving tool. An adjustment member is coupled to the attachment member to adjust and control a driving depth of the fastener driving tool. A stopping head is formed on a rivet die of the fastener driving tool for keeping the rivet die in a chamber of the fastener driving tool and for limiting a distance the rivet die will travel.

16 Claims, 2 Drawing Sheets

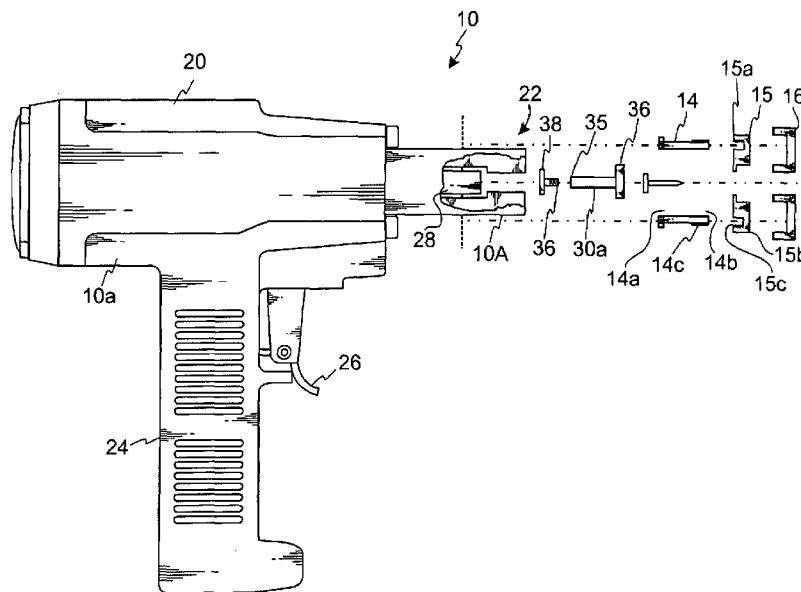

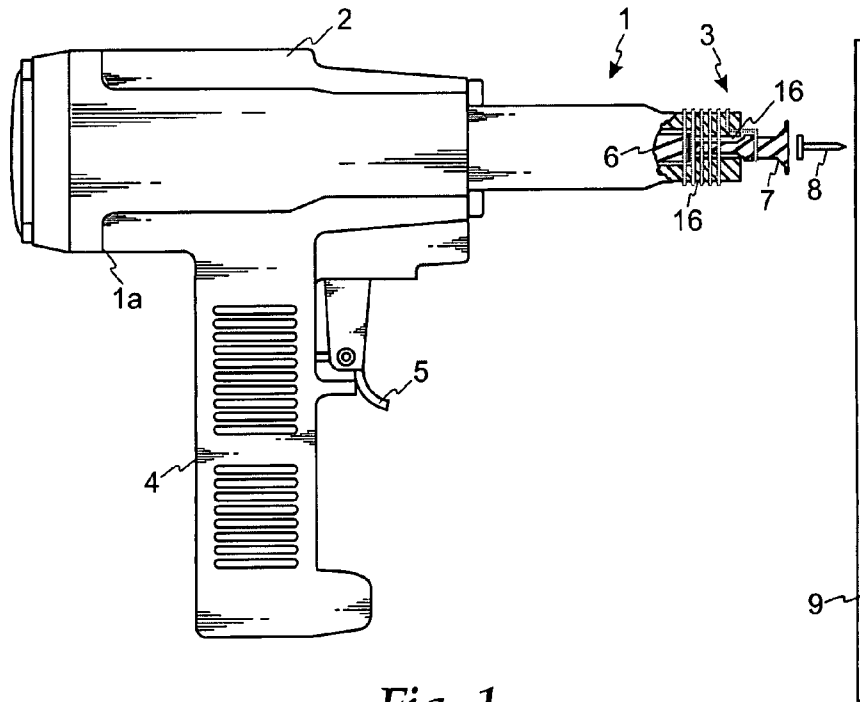

Fig. 1
(prior art)

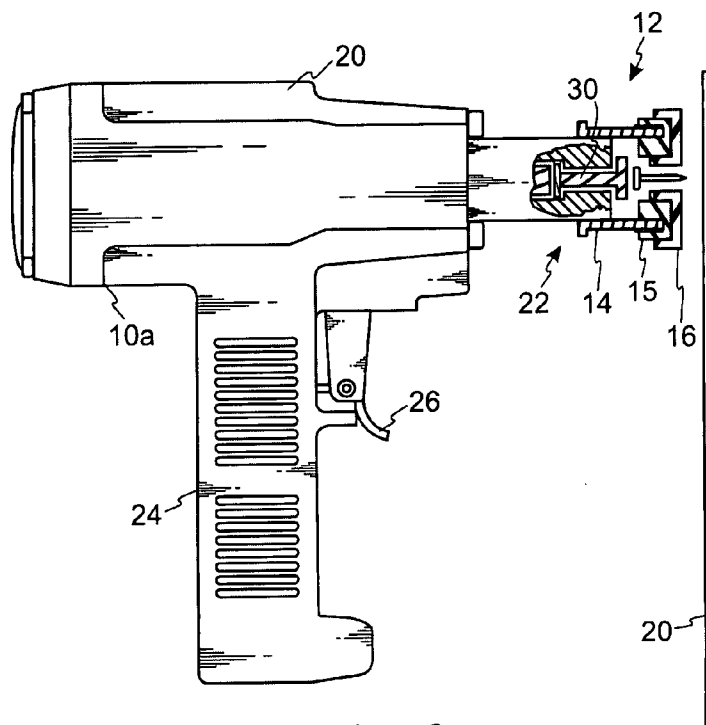

Fig. 2

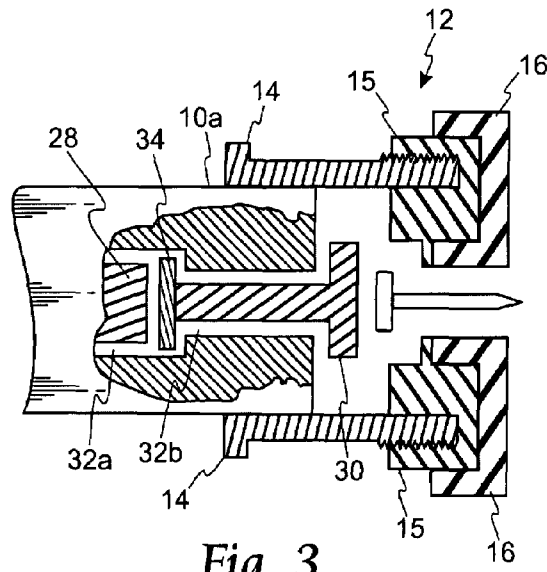

Fig. 3

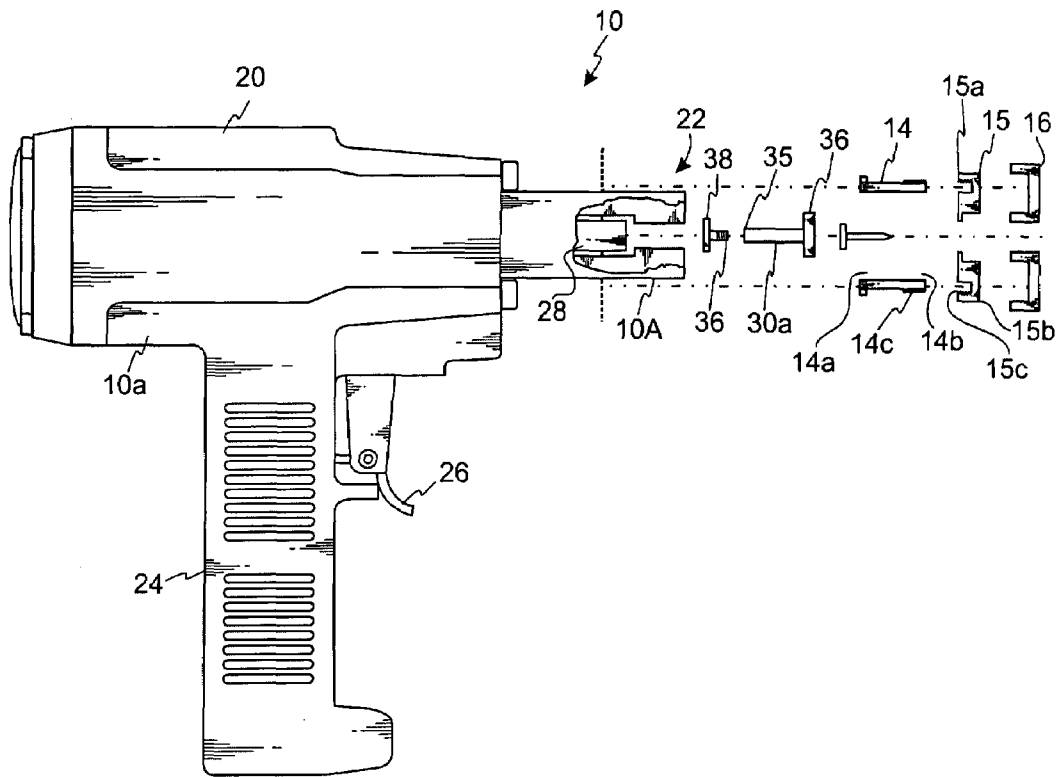

Fig. 4

1

DEVICE FOR CONTROLLED DEPTH RIVETING

BACKGROUND OF THE INVENTION

1. Field of the Invention

The present invention relates generally to the field of rivet guns, and more particularly to a device to control the depth of travel of a rivet die of a rivet gun to limit damage to the installation surface area.

2. Background Information

Rivet guns are used for driving rivets, staples, nails, and other fasteners (hereinafter fasteners) into a surface of an object. A problem with present rivet guns is the inability to control the fastener driving depth. This is due to the inconsistency in driving depth depending on how much driving and recoiling force is created.

It is desirable to allow one to control the depth to which the fastener will be driven. Different applications require different driving depths for the fasteners. For some applications it is desirable to drive the fasteners so they are countersunk below the surface of the substrate. For other applications it may be desirable to have the fastener head flush with the surface of the substrate. In other circumstances, it may be required for the fastener head to stand off from the surface of the substrate.

Many fastener driving tools have attempted to control fastener driving depth. Effectively controlling driving depth has been difficult in the past because each fastener is usually driven with the same amount of energy each time that the tool is fired. This has been known to cause fasteners to be driven to an inconsistent depth when there were variations in the density of the surface of the object. This is especially problematic in the aerospace industry where a rivet gun may be the only means to install a fastener. The use of a rivet gun presents several obstacles. First, the rivet gun may damage the structure of an aircraft should the rivet die of the rivet gun extend too far and contact the surface of the aircraft. If the rivet die contacts the surface of the aircraft with too much force, the rivet die will generally damage the structure of the aircraft. Second, the use of a rivet gun may cause damage to the countersunk areas of the aircraft. If the fastener is fully seated, there is a possibility of micro-cracking the countersunk area of the hole by the rivet gun.

Therefore, it would be desirable to provide a device that overcomes the above problems. The device will allow controlled depth riveting of fasteners in order to prevent damage to a structure being fastened.

SUMMARY OF THE INVENTION

An adjustable depth control device for a fastener driving tool is disclosed. The adjustable depth control device has an attachment member which is used to couple the adjustable depth control device to the fastener driving tool. An adjustment member is coupled to the attachment member to adjust and control a driving depth of the fastener driving tool. A stopping head is formed on a rivet die of the fastener driving tool for keeping the rivet die in a chamber of the fastener driving tool and for limiting a distance the rivet die will travel.

The features, functions, and advantages can be achieved independently in various embodiments of the present inventions or may be combined in yet other embodiments.

2

BRIEF DESCRIPTION OF THE DRAWINGS

The present invention will become more fully understood from the detailed description and the accompanying drawings, wherein:

FIG. 1 is a side view of a prior art fastener driving tool;

FIG. 2 is a side sectional view of an advantageous embodiment of a fastener driving tool of the present invention which allows controlled depth riveting;

FIG. 3 is a magnified cross-sectional side view of the fastener driving tool of the present invention showing an advantageous embodiment of the mechanism which allows controlled depth riveting; and

FIG. 4 is an exploded side view of an advantageous embodiment of the fastener driving tool of the present invention which allows controlled depth riveting.

DETAILED DESCRIPTION OF THE PREFERRED EMBODIMENTS

Referring to FIG. 1, a prior art fastener driving tool 1 is shown. The driving tool 1 has a housing 2. The housing 2 will generally have a hollow interior section which is used to enclose a driving mechanism 3. The housing 2 further includes a handle 4 which extends away from the main body 1a. The handle 4 will have a trigger 5. The trigger 5 is used for actuating the driving tool 1.

The driving mechanism 3 generally includes a driving mass 6 and a rivet die 7. When the trigger 5 is pulled, a driving force will force the driving mass 6 forward causing the driving mass 6 to strike the rear surface of the rivet die 7. The rivet die 7 will strike the head of the fastener 8 driving the fastener 8 into the surface 9 of an object. The rivet die 7 is generally held within the chamber 1b of the driving tool 1 by a spring 1c which is wound around the exterior of the housing 2. However, the prior art driving tool 1 has no way to effectively control the driving depth of the fastener 8. Thus, each fastener 8 is usually driven with the same amount of energy each time that the driving tool 1 is fired. This can cause the fastener 8 to be driven to an inconsistent depth and can cause the rivet die 7 to contact the surface 9 of the object with too much force causing damage to the surface 9.

Referring now to FIGS. 2-4, a fastener driving tool 10 (hereinafter tool 10) which allows controlled depth riveting is shown. The tool 10 has an adjustable depth control device 12. The adjustable depth control device 12 allows controlled depth riveting in order to prevent damage to a surface 20 of a structure. The adjustable depth control device 12 has an attachment device 14, an adjustment device 15, a bumper 16 which is coupled to the adjustment device 15, and a modified rivet die 30.

The adjustable depth control device 12 has an attachment device 14. The attachment device 14 is used to couple the adjustable depth control device 12 to the tool 10. The attachment device 14 is coupled to a front end 10a of the tool 10. The attachment device 14 is tubular in shape and has a first open end 14a and a second open end 14b. The first open end 14a of the attachment device 14 is slide on the tool 10 to couple the attachment device 14 to the tool 10. The diameter of the first open end 14a is slightly smaller than the diameter of the front end 10a of the tool 10. This will keep the adjustable depth control device 12 mounted on the tool 10 and prevent the attachment device 14 from slipping off of the tool 10 during use.

The attachment device 14 is generally formed of a strong and sturdy material. A metal such as heat treated steel or the like may be used for the attachment device 14. However, the

listing of the above is given as an example and should not be seen as to limit the scope of the present invention.

An adjustment device **15** is coupled to the attachment device **14**. The adjustment device **15** will allow one to adjust and control the driving depth of the tool **10**. In accordance with one embodiment of the present invention, the adjustment device **15** is generally circular in shape and has a first end **15a** and a second end **15b**. The first end **15a** of the adjustment device **15** is adjustably coupled to the second end **14b** of the attachment device **14**. The first end **15a** of the adjustment device **15** has a plurality of threads **15c** in an inner perimeter of the first end **15a**. The threads **15c** will engage a plurality of threads **14c** located around an outer perimeter of the second open end **14b** of the attachment device **14**. By rotating the adjustment device **15** in a clockwise or counter clockwise direction, one can adjust and control the driving depth of the tool **10**.

A bumper **16** is coupled to the adjustment device **15**. The bumper **16** is used to prevent the adjustable depth control device **12** from scratching the surface **20** of an object when the tool **10** is being used. The bumper **16** is made of a material that will not scratch the surface **20** of an object. In general a material such as rubber, Teflon or the like is used. The bumper **16** is circular in shape has a first open end **16a** and a second open end **16b**. The first open end **16a** of the bumper **16** is coupled to the second end **15b** of the adjustment device **14**. The second open end **16b** allows the driving mechanism **22** to contact the fastener **40**.

The tool **10** is similar to the driving tool **1**. The tool **10** has a housing **20**. The housing **20** will generally have a hollow interior section which is used to enclose a driving mechanism **22**. The housing **20** further includes a handle **24** which extends away from the main body **10a**. The handle **24** will have a trigger **26**. The trigger **26** is used for actuating the tool **10**.

The driving mechanism **22** generally includes a driving mass **28** and a rivet die **30** which is located in a chamber **32**. The chamber **32** has a first section **32a** having a first diameter and a second section **32b** having a second diameter. The driving mass **28** is located in the first section **32a**. The driving mass **28** is dimensioned so that the driving mass **28** cannot enter the second section **32b**.

The rivet die **30** has a stem **30a** and a striking head **36**. The stem **30a** is positioned in the second section **32b** of the chamber **32** and extends into the first chamber **32a**. Unlike prior art rivet dies, the rivet die **30** has a stopping head **34**. The stopping head **34** is generally a plate member located on an end **35** opposite of the striking head **36** of the rivet die **30**. The stopping head **34** is used to prevent the rivet die **30** from leaving the chamber **32**. The stopping head **34** further limits the distance the rivet die **30** may travel. The stopping head **34** has a length which is greater than the diameter of the second section **32b**. Thus, when the tool **10** is actuated, the stopping head **34** will allow the rivet die **30** to travel a short distance before hitting and stopping at the opening to the second section **32b**. Thus, the stopping head **34** will prevent the rivet die **30** from traveling too far and damaging the surface **20** of the object.

The stopping head **34** may be formed in a plurality of different manners. Prior art rivet dies may even be modified to add the stopping head **34**. In accordance with one embodiment of the present invention, the driven end **35** of the rivet die **30** is counterbored. An adapter rod **36** that is thread on one end is inserted into the counterbored portion of the rivet die **30**. A shouldered nut **38** is then coupled to the adapter rod **36**. By inserting the rivet die **30** with the stopping head **34** into the chamber **32** of the tool **10**, the rivet die **30** is

captured and cannot come out. The rivet die **30** is also limited as to the distance the rivet die **30** may travel. The rivet die **30** can only travel a predetermined length. This allows the operator to install the fastener **40** at any head protrusion desire, eliminating any chance of micro-cracking in the countersink area of the structure. Since the rivet die **30** does not travel past the end of the nose piece of the adjustable depth control device **12**, rivet die **30** contact with the surface **20** is impossible. The bumper **16** eliminates any chance of abrasion of the skin surface from the tool **10**.

This disclosure provides exemplary embodiments of the present invention. The scope of the present invention is not limited by these exemplary embodiments. Numerous variations, whether explicitly provided for by the specification or implied by the specification, such as variations in structure, dimension, type of material and manufacturing process may be implemented by one of skill in the art in view of this disclosure.

What is claimed is:

1. An adjustable depth control device for a fastener driving tool comprising:
 - an attachment member to couple the adjustable depth control device to the fastener driving tool;
 - an adjustment member coupled to the attachment member to adjust and control a driving depth of the fastener driving tool; and
 - a stopping head formed on a rivet die of the fastener driving tool for keeping the rivet die in a chamber of the fastener driving tool and for limiting a distance the rivet die will travel, wherein the stopping head comprises:
 - an adapter rod inserted into a bore formed in an end of the rivet die opposite of a striking head of the rivet die; and
 - a shouldered nut coupled to an end of the adapter rod opposite of an end inserted into the channel.
2. An adjustable depth control device for a fastener driving tool in accordance with claim 1 further comprising a bumper coupled to the adjustment member.
3. An adjustable depth control device for a fastener driving tool in accordance with claim 2 wherein the bumper is formed of a material that prevents scratching of a surface.
4. An adjustable depth control device for a fastener driving tool in accordance with claim 1 wherein the attachment member comprises a tubular member having a first open end and a second open end, the first open end sliding on the fastener driving tool to couple the attachment member to the fastener driving tool.
5. An adjustable depth control device for a fastener driving tool in accordance with claim 4 wherein the adjustable depth control device further comprises:
 - a first set of threads formed around a first open end of the adjustment member; and
 - a second set of threads located around the attachment member, the first set of threads engaging the second set of threads to adjust and control the driving depth of the fastener driving tool.
6. An adjustable depth control device for a fastener driving tool in accordance with claim 1 wherein the stopping head comprises a plate member coupled to an end of the rivet die opposite of a striking head of the rivet die.
7. An adjustable depth control device for a fastener driving tool in accordance with claim 1 wherein the stopping head further comprises:
 - a first set of threads formed on the adapter rod; and
 - a second set of threads formed in the channel to couple the adapter rod to the rivet die.

5

8. An adjustable depth control device for a fastener driving tool in accordance with claim 1 wherein the adjustment member comprises a circular shape member having a first end and a second end, the first end adjustably coupled to the attachment member.

9. A fastener driving tool for axially driving a fastener, comprising:

a gun body having channeling having a first and second section;

a driving mass, wherein the driving mass moves within the first section of the channeling;

a rivet die positioned in the second section of the channeling, an end of the rivet die extending into the first section of the channeling, the driving mass striking the rivet die when the fastener driving tool is actuated;

a stopping head formed on the rivet die for keeping the rivet die in the second section of the channeling and for limiting a distance the rivet die will travel;

an adjustable depth control device coupled to the fastener driving tool to adjust and control a driving depth of the fastener driving tool;

an attachment member to couple the adjustable depth control device to the fastener driving tool; and

an adjustment member coupled to the attachment member to adjust and control a driving depth of the fastener driving tool;

wherein the stopping head comprises:

an adapter rod inserted into a hole formed in an end of the rivet die opposite of a striking head of the rivet die; and

a shouldered nut coupled to an end of the adapter rod opposite of an end inserted into the channel.

10. A fastener driving tool for axially driving a fastener in accordance with claim 9 wherein the adjustable depth control device further comprises a bumper coupled to the adjustment member.

6

11. A fastener driving tool for axially driving a fastener in accordance with claim 10 wherein the bumper is formed of a material that prevents scratching of a surface.

12. A fastener driving tool for axially driving a fastener in accordance with claim 9 wherein the attachment member comprises a tubular member having a first open end and a second open end, the first open end being slide on the fastener driving tool to couple the attachment member to the fastener driving tool.

13. A fastener driving tool for axially driving a fastener in accordance with claim 12 wherein the adjustable depth control device further comprises:

a first set of threads formed around a first open end of the adjustment member; and

second set of threads located around the attachment member the first set of threads engaging the second set of threads to adjust and control the driving depth of the fastener driving tool.

14. A fastener driving tool for axially driving a fastener in accordance with claim 9 wherein the stopping head comprises a plate member coupled to an end of the rivet die opposite of a striking head of the rivet die.

15. A fastener driving tool for axially driving a fastener in accordance with claim 9 wherein the stopping head further comprises:

a first set of threads formed on the adapter rod; and

a second set of threads formed in the channel to coupled ter rod to the rivet die.

16. A fastener driving tool for axially driving a fastener in accordance with claim 9 wherein the adjustment member comprises a circular shape member having a first open end and a second open end, the first open end adjustably coupled to the attachment member.

* * * * *