



**Description**

## BACKGROUND

## 1. Field

**[0001]** The present invention relates to an ice making unit and a refrigerator having the same, and, more particularly, to an ice making unit separably installed in a freezing compartment and a refrigerator having the same.

## 2. Description of the Related Art

**[0002]** In general, a refrigerator is an apparatus incorporating a refrigeration cycle, to refrigerate or freeze articles stored therein using cold air generated from components of the refrigeration cycle. Some refrigerators have an ice making unit installed in a freezing compartment.

**[0003]** Korean Patent Laid-Open Publication No. 10-2003-0060633 discloses an ice making unit and a refrigerator having the same. The disclosed conventional refrigerator includes a body having a freezing compartment therein, an ice making tray, an ice receptacle disposed below the ice making tray to receive ice, and a vessel-shaped ice maker body installed to be pulled out and pushed into the freezing compartment, in which the ice making tray and the ice receptacle are separably installed.

**[0004]** In this case, a plurality of water receiving members is rotatably installed in the ice making tray. Also, a plurality of grips are installed at a front surface of the ice making tray, to rotate the plurality of water receiving members, so as to separate ice made in the respective water receiving members. When any one of the plurality of grips is rotated, the ice made in the corresponding water receiving member can be separated.

**[0005]** However, the above-described conventional ice making unit and refrigerator having the same have a problem of inconvenient supply of water for use in ice making because the ice making tray must be separated from the ice maker body in order to fill water in the water receiving members of the ice making tray.

**[0006]** Another problem of the above-described conventional ice making unit and refrigerator having the same is that it is necessary to fill water in the plurality of water receiving members one by one, and this further complicates supply of water for use in ice making.

**[0007]** In addition, in the above-described conventional ice making unit and refrigerator having the same, every grip used to rotate each of the plurality of water receiving members must be rotated to separate ice made in the plurality of water receiving members, resulting in inconvenient separation of ice made in the water receiving members.

## SUMMARY

**[0008]** In an aspect of the present invention, there is provided an ice making unit to achieve more easy supply of water for use in ice making, and a refrigerator having the same.

**[0009]** In an aspect of the present invention, there is provided an ice making unit to achieve more easy supply of water into a plurality of ice making trays, and a refrigerator having the same.

**[0010]** In an aspect of the present invention, there is provided an ice making tray to achieve more convenient separation of ice made in a plurality of ice making trays, and a refrigerator having the same.

**[0011]** In accordance with an aspect of the invention, there is provided an ice making unit, which takes the form of a kit separably installed in a freezing compartment, wherein the ice making unit includes a water supply tank to supply water; an ice making case defining an external appearance of the ice making unit, the ice making case being formed, at an upper portion of a front surface thereof, with a water supply tank installation hole to allow the water supply tank to be slidably installed therethrough; at least one ice making tray installed in the ice making case to receive the water supplied from the water supply tank; and an ice separating device to separate ice from the at least one ice making tray, and the water supply tank is coupled to or separated from the ice making case via forward and rearward sliding movement thereof.

**[0012]** The ice making case may be formed, at one side thereof, with a first opening to observe ice making in the at least one ice making tray, and the at least one ice making tray may include a plurality of ice making trays.

**[0013]** A transparent window may be rotatably installed, at an upper end thereof, to an upper side of the first opening, to open or close the first opening.

**[0014]** The at least one ice making tray may include an upper ice making tray and a lower ice making tray arranged up and down in parallel within the ice making case.

**[0015]** A guide tray may be provided between the water supply tank and the upper ice making tray, to distribute and supply the water discharged from the water supply tank into the upper ice making tray and the lower ice making tray.

**[0016]** The interior of the guide tray may be divided into two parts to distribute and supply the water into an upper ice making tray and a lower ice making tray, and may include a water supply hole to guide the water into the upper ice making tray and a water supply tube to guide the water into the lower ice making tray.

**[0017]** The ice separating device may include a lever to be rotated about one end thereof upon receiving an external force, a driving gear to be rotated by the lever, and a pair of driven gears to be rotated by the driving gear so as to rotate the upper ice making tray and lower ice making tray, respectively.

**[0018]** An ice storage vessel may be provided in a low-

er region of the ice making case, to receive the ice separated from the ice making tray, and the ice making case may be formed, at a lower portion of the front surface thereof, with a second opening, to allow the ice storage vessel to be slidably installed therethrough.

**[0019]** In accordance with another aspect of the present invention, there is provided a refrigerator including a body having a freezing compartment, a door to open or close the freezing compartment, and an ice making unit taking the form of a kit separably installed to any one of the freezing compartment and the door, wherein the ice making unit includes a water supply tank to supply water; an ice making case defining an external appearance of the ice making unit, the ice making case being formed, at an upper portion of a front surface thereof, with a water supply tank installation hole to allow the water supply tank to be slidably installed therethrough; at least one ice making tray installed in the ice making case to receive the water supplied from the water supply tank; and an ice separating device to separate ice from the at least one ice making tray, and the water supply tank being coupled to or separated from the ice making case via forward and rearward sliding movement thereof.

#### BRIEF DESCRIPTION OF THE DRAWINGS

**[0020]** These and/or other aspects, features, and advantages of exemplary embodiments of the invention will become apparent and more readily appreciated from the following description of exemplary embodiments, taken in conjunction with the accompanying drawings, of which:

FIG. 1 is a side sectional view illustrating a refrigerator in accordance with an exemplary embodiment of the present invention;

FIG. 2 is a perspective view illustrating an ice making unit of the refrigerator in accordance with an exemplary embodiment of the present invention;

FIG. 3 is an exploded perspective view of the ice making unit of the refrigerator in accordance with an exemplary embodiment of the present invention; and FIGS. 4 and 5 are perspective views illustrating operation of the ice making unit of the refrigerator in accordance with an exemplary embodiment of the present invention.

#### DETAILED DESCRIPTION OF EMBODIMENTS

**[0021]** Reference will now be made in detail to exemplary embodiments of the present invention, examples of which are illustrated in the accompanying drawings, wherein like reference numerals refer to like elements throughout. Exemplary embodiments are described below to explain the present invention by referring to the figures.

**[0022]** Referring to FIG. 1 illustrating a refrigerator in accordance with an exemplary embodiment of the present invention, the refrigerator includes a body 10 de-

fining an external appearance of the refrigerator and having an open front surface, the body 10 being formed therein with a freezing compartment 11 to freeze articles stored therein, and a door 20 hingedly coupled at one side of the body 10 to open or close the freezing compartment 11.

**[0023]** A compressor 12 to compress a refrigerant is installed in a rear lower region of the body 10. An evaporator 13 to generate cold air and a blowing fan 14 to generate suction and blowing force for circulation of the cold air generated from the evaporator 13 within the freezing compartment 11 are installed at the rear side of the freezing compartment 11. The freezing compartment 11 incorporates a plurality of shelves 15 to divide the interior of the freezing compartment 11 for efficient storage of various articles. The door 20 is provided at an inner surface thereof with a plurality of door shelves 21 to store beverage cans or containers, etc.

**[0024]** A refrigerator in accordance with an exemplary embodiment of the present invention includes an ice making unit 30 installed in the freezing compartment 11 to make ice. The ice making unit 30, used in the refrigerator in accordance with an exemplary embodiment of the present invention, is an independent kit, and the ice making unit 30 is separably installed in the freezing compartment 11 of the refrigerator. Specifically, the ice making unit 30 is put on a shelf in the freezing compartment 11, and thus, as shown in FIG. 1, a vertical position of the ice making unit 30 can be freely changed if necessary.

**[0025]** The ice making unit 30, as shown in FIGS. 2 and 3, includes an ice making case 300 defining an external appearance of the ice making unit 30, a plurality of ice making trays 310U and 310L disposed in the ice making case 300 to make ice therein, a water supply tank 320 disposed above the plurality of ice making trays 310U and 310L to receive water to be supplied into the plurality of ice making trays 310U and 310L, a guide tray 330 to distribute the water from the water supply tank 320 so as to guide the water into the plurality of ice making trays 310U and 310L, an ice separating device 340 to separate ice, made in the ice making trays 310U and 310L, from the ice making trays 310U and 310L, and an ice storage vessel 350 disposed below the ice making trays 310U and 310L to receive the ice separated from the plurality of ice making trays 310U and 310L. By allowing the water supply tank 320 to be separably installed to the ice making case 300 of the ice making unit 30, supply of water for use in ice making can be carried out by simply coupling the water supply tank 320 into the ice making case 300.

**[0026]** The ice making case 300 is installed at a front surface thereof with the ice separating device 340. The ice making case 300 includes a case body 301 in which the plurality of ice making trays 310U and 310L are arranged, a front cover 302 to cover a front surface of the case body 301, and a top cover 303 to define an upper surface of the case body 301. The case body 301 of the ice making case 300 is formed with a first opening 301a to allow a user to observe ice making in the ice making

trays 310U and 310L. The first opening 301 a is provided with a transparent window 304. The transparent window 304 is rotatably connected, at an upper end thereof, at the upper side of the first opening 301 a, to open or close the first opening 301 a via pivotal rotation thereof. In the present exemplary embodiment, the upper end of the transparent window 304 is rotatably coupled to one side of the top cover 303 that defines the upper surface of the ice making case 300. Accordingly, even in a state wherein the transparent window 304 closes the first opening 301a, it is possible to observe ice making in the plurality of ice making trays 310U and 310L from the outside through the transparent window 304.

**[0027]** The front cover 302 of the ice making tray 300 is formed, at one side of an upper portion thereof, with a water supply tank installation hole 302a, to allow the water supply tank 320 to slide forward and rearward there-through, thereby being pulled out and pushed into the ice making case 300, or being completely separated from the ice making case 300. The case body 301 is formed, at a lower portion of a front surface thereof, with a second opening 301b to allow the ice storage vessel 350 to slide forward and rearward therethrough, thereby being pulled out and pushed into the ice making case 300.

**[0028]** The top cover 303 of the ice making case 300 is formed with a plurality of through-holes 303a, to introduce cold air in the freezing compartment 11 into the case body 301.

**[0029]** In the present exemplary embodiment, a pair of ice making trays 310U and 310L is arranged up and down in parallel. For convenience of description, one of the ice making trays 310U disposed above is referred to as an upper ice making tray 310U, and the other one disposed below is referred to as a lower ice making tray 310L.

**[0030]** The pair of ice making trays 310U and 310L is rotatably installed up and down in parallel, and each is formed, at an upper surface thereof, with a plurality of ice making recesses 311 having an arched cross section.

**[0031]** The guide tray 330 is installed at an upper portion of a rear surface of the case body 301 of the ice making case 300. The guide tray 330 is divided into two parts, namely, a first water supply guide portion 330a and a second water supply guide portion 330b, to distribute and guide the water discharged from the water supply tank 320 into the upper ice making tray 310U and the lower ice making tray 310L. The first water supply guide portion 330a of the guide tray 330 is located immediately above the upper ice making tray 310U, and the second water supply guide portion 330b is located beside and above the upper ice making tray 310U. The first water supply guide portion 330a is formed with a water supply hole 331 to supply the water from the first water supply guide portion 330a into the upper ice making tray 310U. The second water supply guide portion 330b is formed with a water supply tube 332 to supply the water from the second water supply guide portion 330b into the lower ice making tray 310L. For this, the water supply tube 332

extends obliquely downward.

**[0032]** Accordingly, a part of the water discharged from the water supply tank 320 into the guide tray 330 is delivered to the upper ice making tray 310U through the water supply hole 331 formed at the first water supply guide portion 330a, and the remaining water is delivered to the lower ice making tray 310L through the water supply tube 332 formed at the second water supply guide portion 330b. As the water in the water supply tank 320 is distributed into the pair of ice making trays 310U and 310L through the guide tray 330, supply of water into the pair of ice making trays 310U and 310L can be accomplished in a very simple manner.

**[0033]** The ice separating device 340 is a device to rotate the ice making trays 310U and 310L so as to separate the ice made in the ice making trays 310U and 310L. In the present exemplary embodiment, the ice separating device 340 simultaneously rotates the pair of ice making trays 310U and 310L, thereby simultaneously separating the ice from the pair of ice making trays 310U and 310L.

**[0034]** The ice separating device 340 includes a lever 341 to be rotated about one end thereof upon receiving an external force, a driving gear 342 to be rotated by the lever 341, and a pair of driven gears 343 to be rotated upon receiving rotating force of the driving gear 342 so as to rotate the pair of ice making trays 310U and 310L, respectively. In this case, the driving gear 342 and the pair of driven gears 343 are installed at the front surface of the case body 301. A gear cover 306 is provided between the case body 301 and the front cover 302, to cover the driving gear 342 and the pair of driven gears 343. The gear cover 306 is centrally formed with a lever installation hole 306a, to allow one end of the lever 341 to be coupled to the driving gear 342. Also, a lever guide slot 302b extends lengthwise vertically in one side of the front cover 302, to guide vertical movement of the lever 341.

**[0035]** One end of the lever 341 is coupled to the center of the driving gear 342. Accordingly, as the lever 341 is rotated about one end thereof, the driving gear 342 is rotated together with the lever 341. The pair of driven gears 343 are arranged at upper and lower positions of the front surface of the ice making case 300 and are engaged with the driving gear 342. As the driven gears 343 are rotated according to rotation of the driving gear 342, they rotate the pair of ice making trays 310U and 310L, respectively. In this case, the driving gear 342 is elastically supported in a circumferential direction thereof by a torsion spring (not shown), such that it is rotated in a direction upon receiving an external force applied to the lever 341, and then, is returned to an original position thereof.

**[0036]** As shown in FIG. 4, if the user forces the lever 341 to rotate about one end thereof in a state wherein the ice making recesses 311 face upward, the driving gear 342 is rotated in a direction together with the lever 341, and simultaneously, the pair of driven gears 343

and the pair of ice making trays 310U and 310L connected to the respective driven gears 343 are rotated as shown in FIG. 5, causing the ice made in the pair of ice making trays 310U and 310L to be separated on the whole. Accordingly, with operation of the single lever 341, all the ice made in the pair of ice making trays 310U and 310L can be separated, resulting in convenient use of the ice making unit 30.

**[0037]** After the manual external force applied to the lever 341 is released, the driving gear 342 is rotated in an opposite direction by an elastic restoration force of the torsion spring, causing the lever 341, the driven gears 343, and the pair of ice making trays 310U and 310L to be returned to their original positions as shown in FIG. 4.

**[0038]** Although a few exemplary embodiments of the present invention have been shown and described, it would be appreciated by those skilled in the art that changes may be made in these exemplary embodiments without departing from the principles and spirit of the invention, the scope of which is defined in the claims and their equivalents.

## Claims

1. An ice making unit, which takes the form of a kit separably installed in a freezing compartment, the ice making unit comprising:

a water supply tank to supply water;  
 an ice making case defining an external appearance of the ice making unit, the ice making case being formed, at an upper portion of a front surface thereof, with a water supply tank installation hole to allow the water supply tank to be slidably installed therethrough;  
 at least one ice making tray installed in the ice making case to receive the water supplied from the water supply tank; and  
 an ice separating device to separate ice from the at least one ice making tray,  
 wherein the water supply tank is coupled to or separated from the ice making case via forward and rearward sliding movement thereof.

2. The ice making unit according to claim 1, wherein the ice making case is formed, at one side thereof, with a first opening to observe ice making in the at least one ice making tray.

3. The ice making unit according to claim 2, wherein a transparent window is rotatably installed, at an upper end thereof, to an upper side of the first opening, to open or close the first opening.

4. The ice making unit according to claim 1, wherein the at least one ice making tray includes an upper ice making tray and a lower ice making tray arranged

up and down in parallel within the ice making case.

5. The ice making unit according to claim 4, further comprising a guide tray, which is provided between the water supply tank and the upper ice making tray, to distribute and supply the water discharged from the water supply tank into the upper ice making tray and the lower ice making tray.

6. The ice making unit according to claim 5, wherein the interior of the guide tray is divided into two parts to distribute and supply the water into the upper ice making tray and the lower ice making tray, and includes a water supply hole to guide the water into the upper ice making tray and a water supply tube to guide the water into the lower ice making tray.

7. The ice making unit according to claim 4, wherein the ice separating device includes a lever to be rotated about one end thereof upon receiving an external force, a driving gear to be rotated by the lever, and a pair of driven gears to be rotated by the driving gear so as to rotate the upper ice making tray and lower ice making tray, respectively.

8. The ice making unit according to claim 1, wherein an ice storage vessel is provided in a lower region of the ice making case, to receive the ice separated from the ice making tray, and wherein the ice making case is formed, at a lower portion of the front surface thereof, with a second opening, to allow the ice storage vessel to be slidably installed therethrough.

9. A refrigerator comprising:

a body having a freezing compartment;  
 a door to open or close the freezing compartment; and

an ice making unit taking the form of a kit separably installed to any one of the freezing compartment and the door,  
 wherein the ice making unit comprises:

a water supply tank to supply water;  
 an ice making case defining an external appearance of the ice making unit, the ice making case being formed, at an upper portion of a front surface thereof, with a water supply tank installation hole to allow the water supply tank to be slidably installed therethrough;

at least one ice making tray installed in the ice making case to receive the water supplied from the water supply tank; and

an ice separating device to separate ice from the at least one ice making tray, and wherein the water supply tank is coupled to or separated from the ice making case via forward and rearward sliding movement thereof.

10. The refrigerator according to claim 9, wherein the ice making case is formed, at one side thereof, with a first opening to observe ice making in the at least one ice making tray; and  
wherein a transparent window is rotatably installed, at an upper end thereof, to an upper side of the first opening, to open or close the first opening. 5
11. The refrigerator according to claim 9, wherein the at least one ice making tray includes an upper ice making tray and a lower ice making tray arranged up and down in parallel within the ice making case. 10
12. The refrigerator according to claim 11, further comprising a guide tray, which is provided between the water supply tank and the upper ice making tray, to distribute and supply the water discharged from the water supply tank into the upper ice making tray and the lower ice making tray. 15  
20
13. The refrigerator according to claim 12, wherein the interior of the guide tray is divided into two parts to distribute and supply the water into the upper ice making tray and the lower ice making tray, and includes a water supply hole to guide the water into the upper ice making tray and a water supply tube to guide the water into the lower ice making tray. 25
14. The refrigerator according to claim 11, wherein the ice separating device includes a lever to be rotated about one end thereof upon receiving an external force, a driving gear to be rotated by the lever, and a pair of driven gears to be rotated by the driving gear so as to rotate the upper ice making tray and lower ice making tray, respectively. 30  
35
15. The refrigerator according to claim 9, wherein an ice storage vessel is provided in a lower region of the ice making case, to receive the ice separated from the ice making tray, and  
wherein the ice making case is formed, at a lower portion of the front surface thereof, with a second opening, to allow the ice storage vessel to be slidably installed therethrough. 40  
45

50

55

FIG. 1

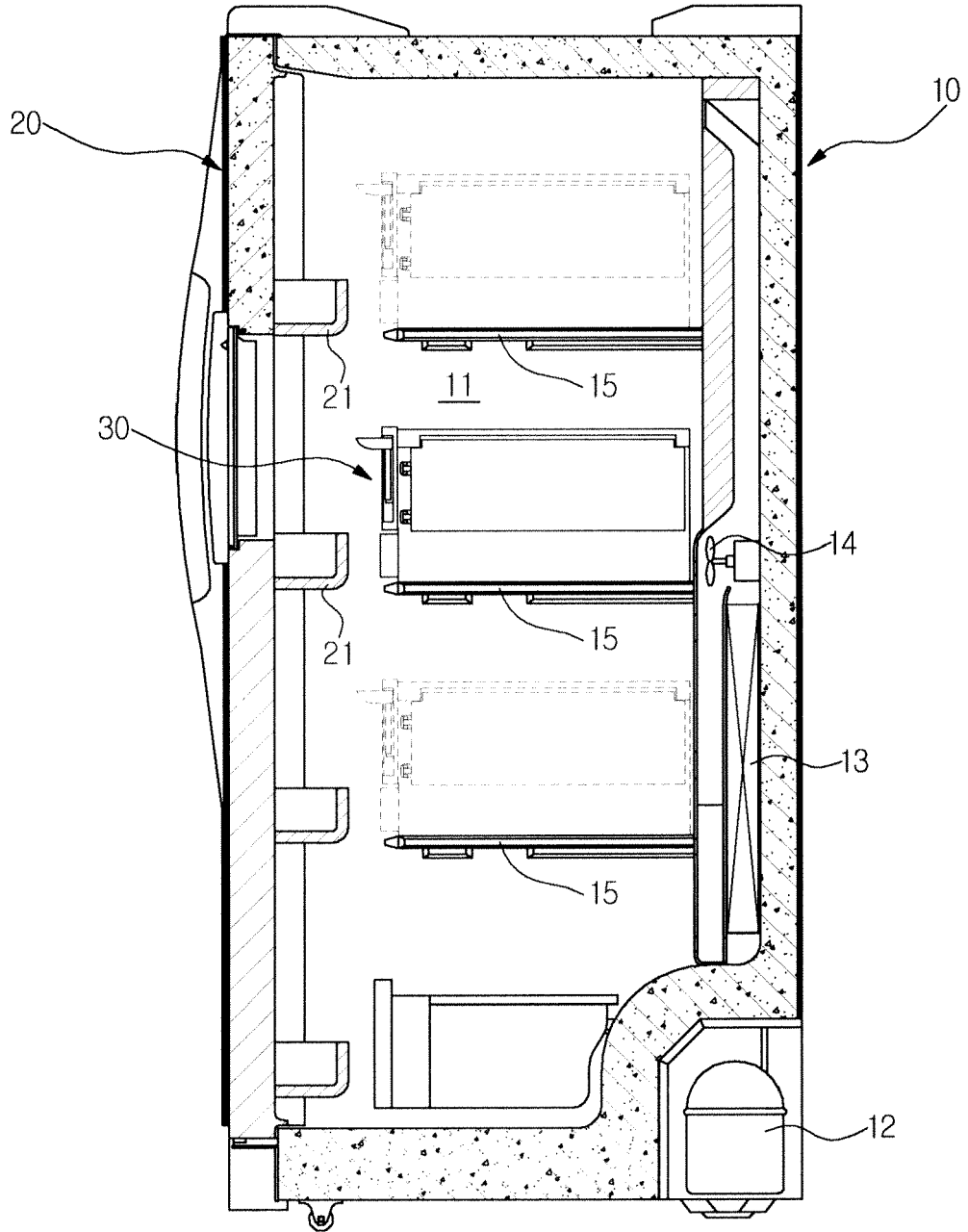

FIG. 2

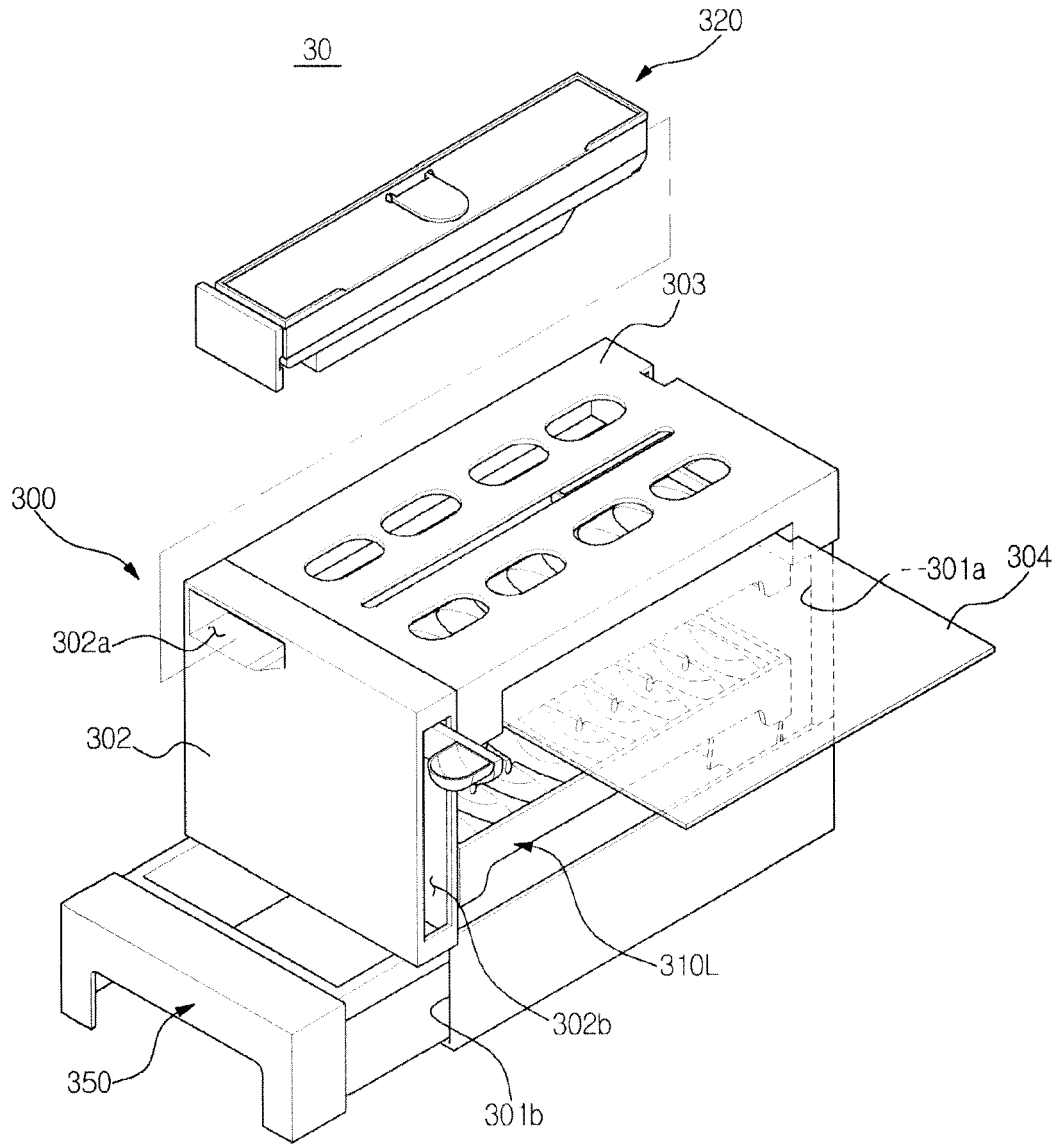

FIG. 3

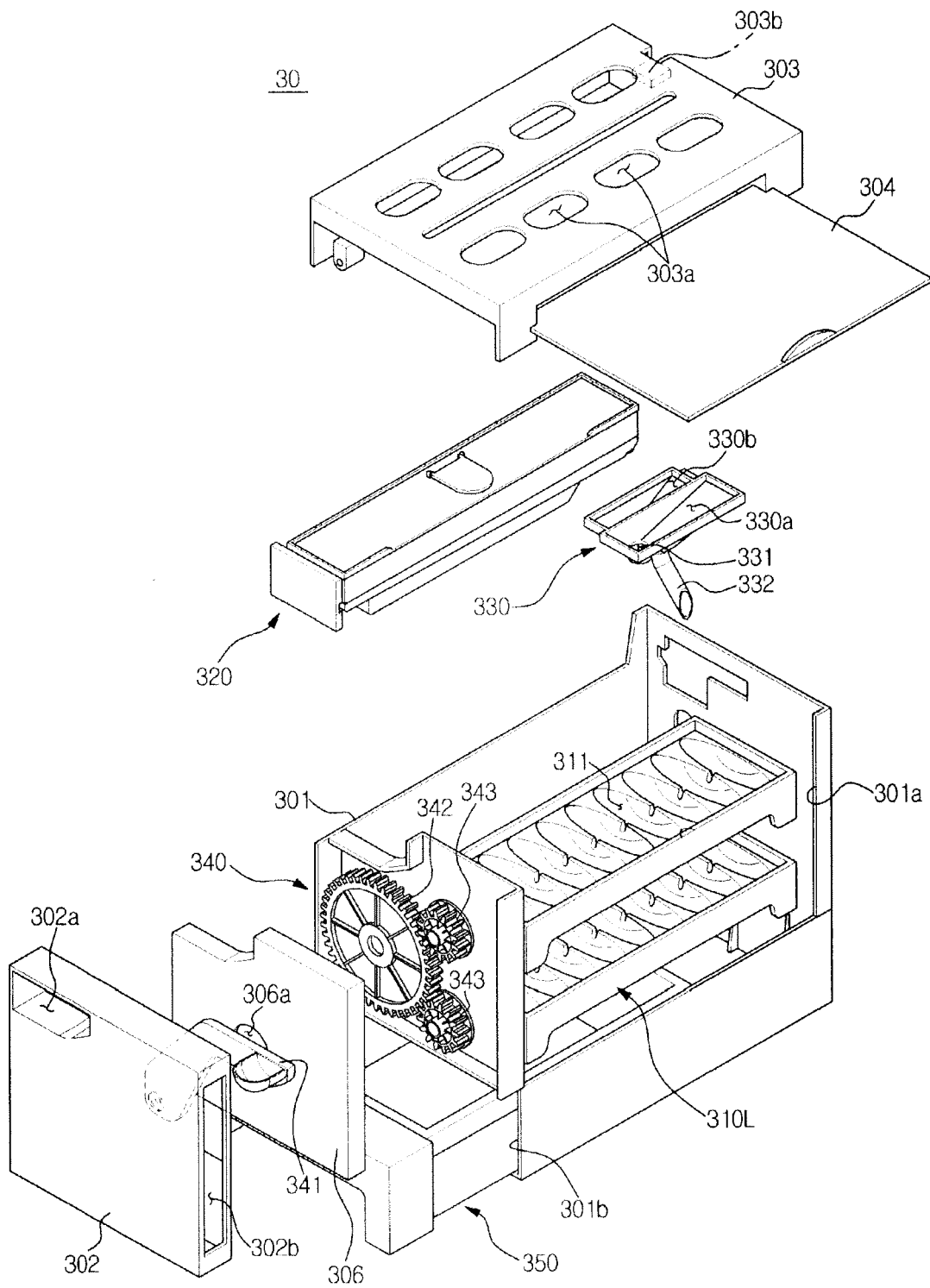

FIG. 4

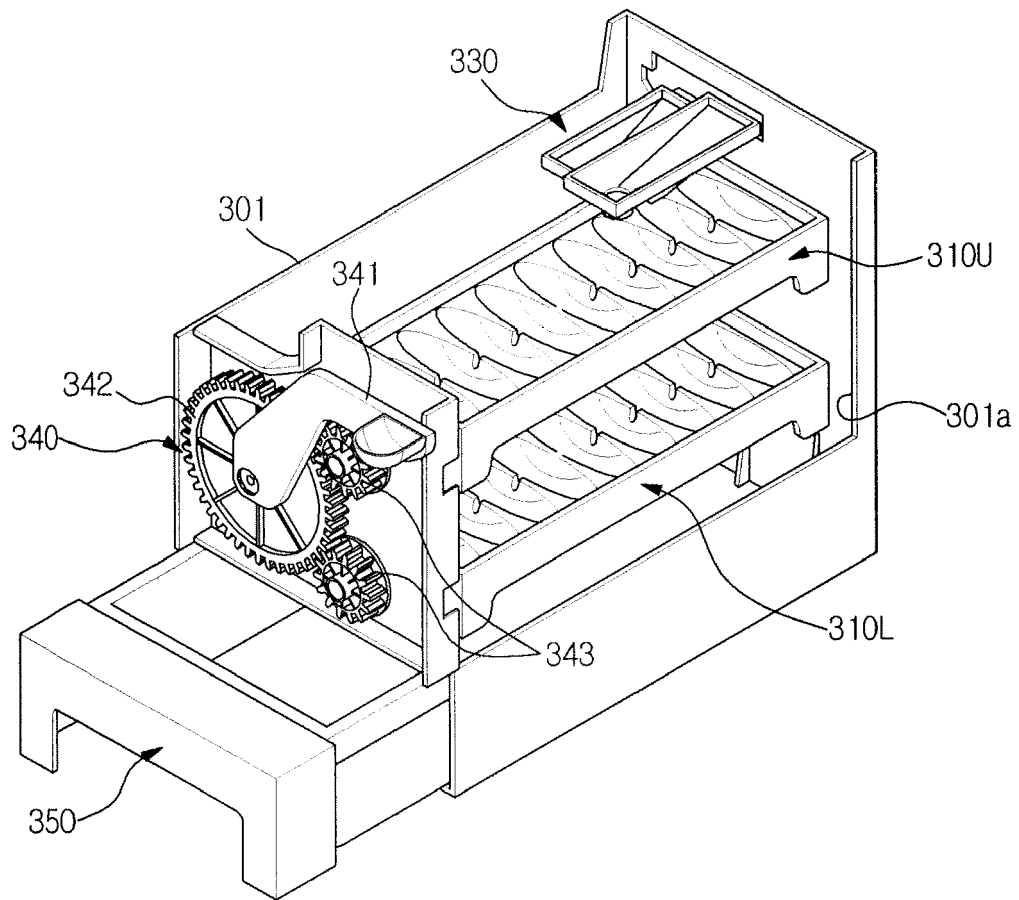
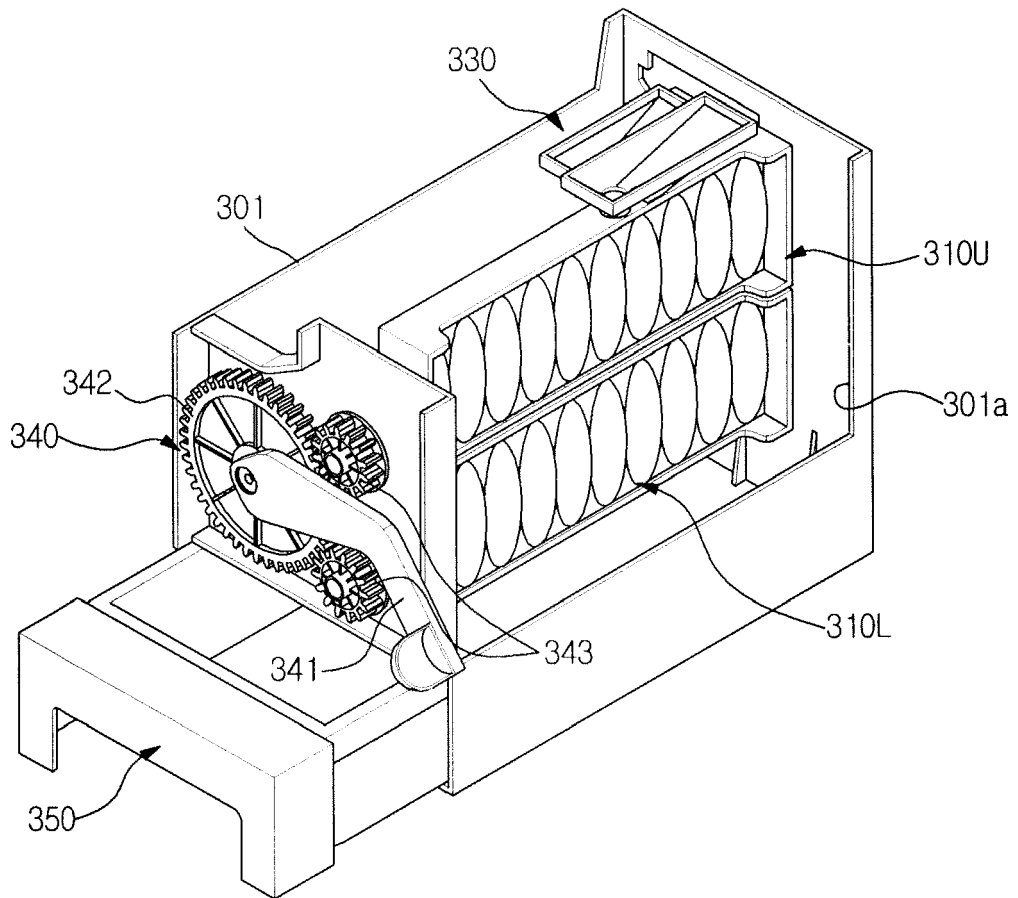

FIG. 5



**REFERENCES CITED IN THE DESCRIPTION**

*This list of references cited by the applicant is for the reader's convenience only. It does not form part of the European patent document. Even though great care has been taken in compiling the references, errors or omissions cannot be excluded and the EPO disclaims all liability in this regard.*

**Patent documents cited in the description**

- KR 1020030060633 [0003]