

(No Model.)

J. J. BERRY.
TANK FLUSHING VALVE.

No. 522,397.

Patented July 3, 1894.

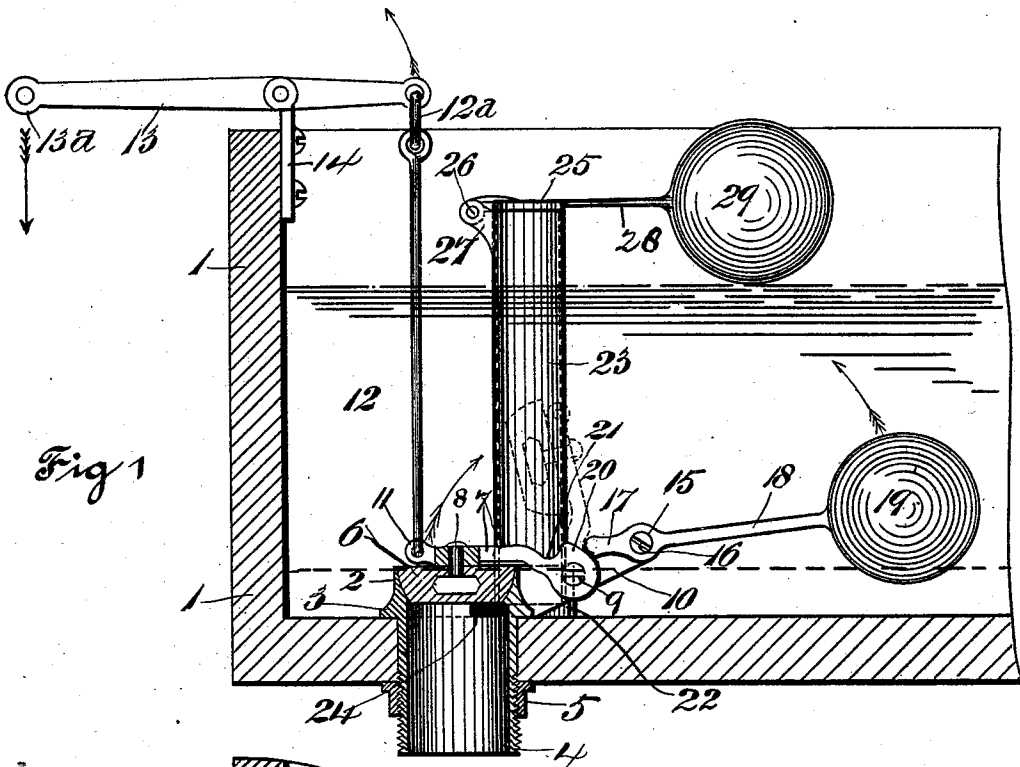

Fig 1

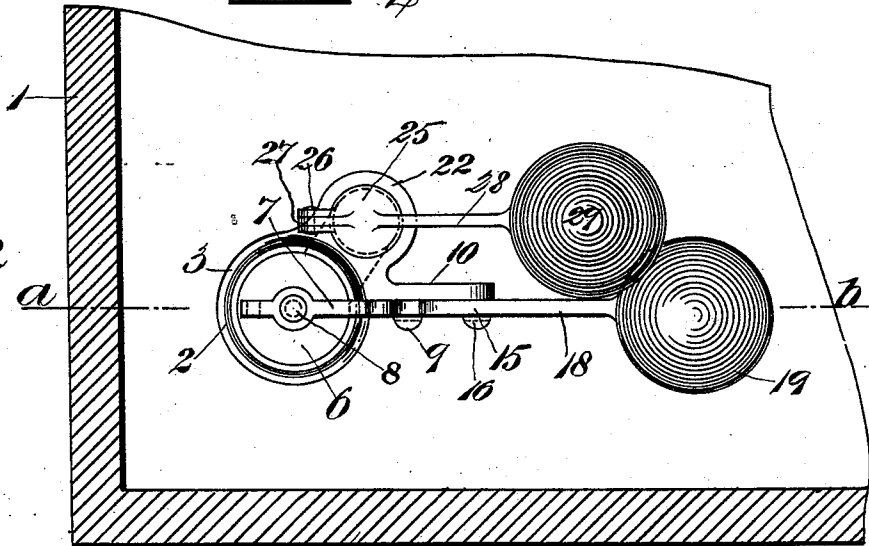

Fig 2

Witnesses

Edw. E. Paddock.
C. P. R. Wapenbrans.

Inventor

John J. Berry.
By *Chompson & Bell* Attorneys

UNITED STATES PATENT OFFICE.

JOHN J. BERRY, OF INDIANAPOLIS, INDIANA.

TANK FLUSHING-VALVE.

SPECIFICATION forming part of Letters Patent No. 522,397, dated July 3, 1894.

Application filed June 5, 1893. Serial No. 476,626. (No model.)

To all whom it may concern:

Be it known that I, JOHN J. BERRY, a citizen of the United States, residing at Indianapolis, in the county of Marion and State of Indiana, have invented new and useful Improvements in Tank Flushing-Valves, of which the following is a specification.

My invention relates to new and useful improvements in flushing valves for use in connection with water tanks of water-closets, and will be hereinafter more fully set forth.

The object of my invention is to provide simple means for automatically retaining and locking the flushing valve in its open position till all the water or nearly all the water contained in the tank has been discharged. I attain this object by means of the apparatus illustrated in the accompanying drawings, in which similar numbers of reference designate like parts throughout the several views.

Figure 1. is a broken sectional elevation of a tank and the flush valve taken through the line A. B. see Fig. 2.; and, Fig. 2. is a plan of the same.

The flushing valve is secured to the bottom of the tank 1. and is composed of the valve seat 2. having the integral collar 3, formed thereon and the threaded stem 4. to which the flushing pipe connecting with the closet basin is connected by a suitable coupling. The clamping nut 5. is screwed on the threaded portion of the stem to clamp the bottom of the tank 1. to form a water-tight joint, and to securely hold said valve and its connections in position. The valve 6. of the flushing valve, is preferably of rubber, with its bearing surface or seat of a spherical or zone form to accurately fit the seat 2. and is secured to the pivotal arm 7, by means of the rivet 8. The pivotal arm 7, of the valve is pivoted at one end on the pin 9, securely screwed into the arm 10, formed integral on the valve seat 2. the opposite end of the end of said arm having the eye 11, formed therein and to which is secured or attached the pull up rod 12. The opposite end of the pull-up rod 12, is connected to the end of the opening lever 13, by a suitable link 12^a. said lever 13, pivoted on the supporting stand 14, secured on the side of the tank. To the end of the lever 13, is secured a suitable wire or chain

leading to the closet and terminating in a suitable handle or grip by which connection the flush valve is operated to open.

On the extreme end of the arm 10, is pivoted the lever 15, on the pin 16, said lever having the shorter arm or engaging toe 17, and the longer arm 18, formed in one integral piece; said longer arm being provided with the ball float 19, for the purpose of automatically operating said engaging toe 17, and will be hereinafter referred to and more particularly described.

A portion 20, of the pivotal end of the valve arm 7, toward the engaging or locking toe 17, is of a cam form, against which cam 20, said engaging toe bears or rests to retain the valve 6 in closed position on its seat. On the top edge of the valve lever and next to the cam portion 20, is formed the gap or notch 21. into which the engaging toe 17, falls or engages to hold the valve 6, in its open position when the latter is moved to open as in the position shown in dotted lines in Fig. 1.

On the side of the valve seat 2, is formed the lug or base 22, to which is connected the vertically projecting waste pipe 23, which is connected with the flush pipe by the opening 24, cast in said lug and valve seat. On the top end of the pipe 23, is pivotally secured the flap float valve 25, by the pin 26, secured firmly in the lugs 27, formed on the end of the waste pipe 23. To the end of the lever 28, is secured the ball float 29, which by its buoyancy raises said valve 25, when the water in the tank has attained a certain height above the level of the top of said pipe. I provide the automatically opening flap valve 25, on the top of the waste pipe 23, for the purpose of preventing the disagreeable gurgling sound peculiar to vertical waste pipes in water tanks; this is fully accomplished by means of the said valve by merely permitting a small opening to waste water and therefore excluding the entrance of air which produces the sound. The end of the pipe 23 may be bent downwardly in siphon form which will also act to prevent any sound of escaping water.

The operation of the apparatus is as follows:—The end of the lever 13, Fig. 1. is moved manually in the direction of the arrow till the valve 6, is moved into the position shown in dotted lines, at which position the toe 17,

engages the notch or gap 21. into which said toe 17, is moved by the buoyancy of the ball float 19 of the lever 15, which holds the said valve 6, in its open position till such times as the level of the water contained in the tank falls sufficiently to no longer buoy up the float 19, and thereby release the toe 17, from the notch 21. to permit the valve 6, to drop on its seat to close. Simultaneously with this movement the water supply valve, not shown, operates to open to admit a fresh supply of water to the tank to float the float 19, and to operate the toe 17, to exert a force against the cam 20 to press the valve 6, firmly on its seat. The supply valve of the tank will form the subject matter of another application.

It is obvious that the lever 15, may be of any desired length within the limits of the interior of the tank and may be curved upwardly or downwardly as a greater or lesser amount of water is required in the tank to be discharged at one flushing.

Having thus fully described the nature and operation of my invention, what I claim as new and useful, and desire to cover by Letters Patent of the United States therefor, is—

1. In a flushing valve the combination with a suitable pivotal escape valve and its seat, of a pivotal arm pivotally secured on said valve seat and whereto said valve is secured,

said arm having its pivotal end cam-shaped and provided with a notch or gap adjacent to said cam and intermediate between the valve and its pivot, and a float lever having a shorter arm or toe adapted to bear on said cam and to work into engagement with said gap or notch, substantially as and for the purpose set forth.

2. In a flushing valve, the combination with a suitable escape valve and its seat, of a pivotal arm pivotally secured on said valve seat and whereto said valve is secured, said arm having its pivotal end cam-shaped and provided with a notch or gap adjacent to said cam and intermediate between said valve and its pivot, a float lever having a shorter arm or toe adapted to bear on said cam and to work into engagement with said gap or notch, a pivotal manually operated lever, a rod connected to the pivotal valve and a link connecting said rod to said manually operated lever, all arranged and combined substantially as and for the purpose set forth.

In testimony whereof I have hereunto set my hand in the presence of two subscribing witnesses.

JOHN J. BERRY.

Witnesses:

THOMPSON R. BELL,
JAMES E. BERRY.