

(19)



(11)

EP 2 020 397 A1

(12)

EUROPEAN PATENT APPLICATION

(43) Date of publication:
04.02.2009 Bulletin 2009/06

(51) Int Cl.:
B66B 5/04 (2006.01)

(21) Application number: **07380228.2**

(22) Date of filing: **03.08.2007**

(84) Designated Contracting States:
AT BE BG CH CY CZ DE DK EE ES FI FR GB GR HU IE IS IT LI LT LU LV MC MT NL PL PT RO SE SI SK TR
Designated Extension States:
AL BA HR MK RS

(71) Applicant: **Thyssenkrupp Elevator Manufacturing Spain S.L.**
28021 Madrid (ES)

(72) Inventor: **Sanchez Alvarez, José Manuel,**
c/o Thyssenkrupp
28021 Madrid (ES)

(74) Representative: **Carvajal y Urquijo, Isabel et al**
Clarke, Modet & Co.
Goya 11
28001 Madrid (ES)

(54) **Apparatus and system for detecting elevator car overspeed**

(57) The invention relates to an apparatus and system for detecting overspeed of elevator components such as a car or a counterweight having: a wheel, with an auxiliary surface or auxiliary wheel (100), configured to run on a first surface (210) of a travel rail (200) of the elevator component; an actuating device for actuating a braking mechanism of the elevator component; a speed detection device for generating a synchronized alternating movement with the speed of the elevator component;

the speed detection device being configured to not generate the synchronized alternating movement when a predetermined speed of the elevator component is exceeded and to thus activate the actuating device (300). In the system of the invention, the apparatus can be arranged in an upper or lower part of the elevator component. In the first case, the transmission device has a plurality of levers (910); in the second case, it has pinions (920) and chains.

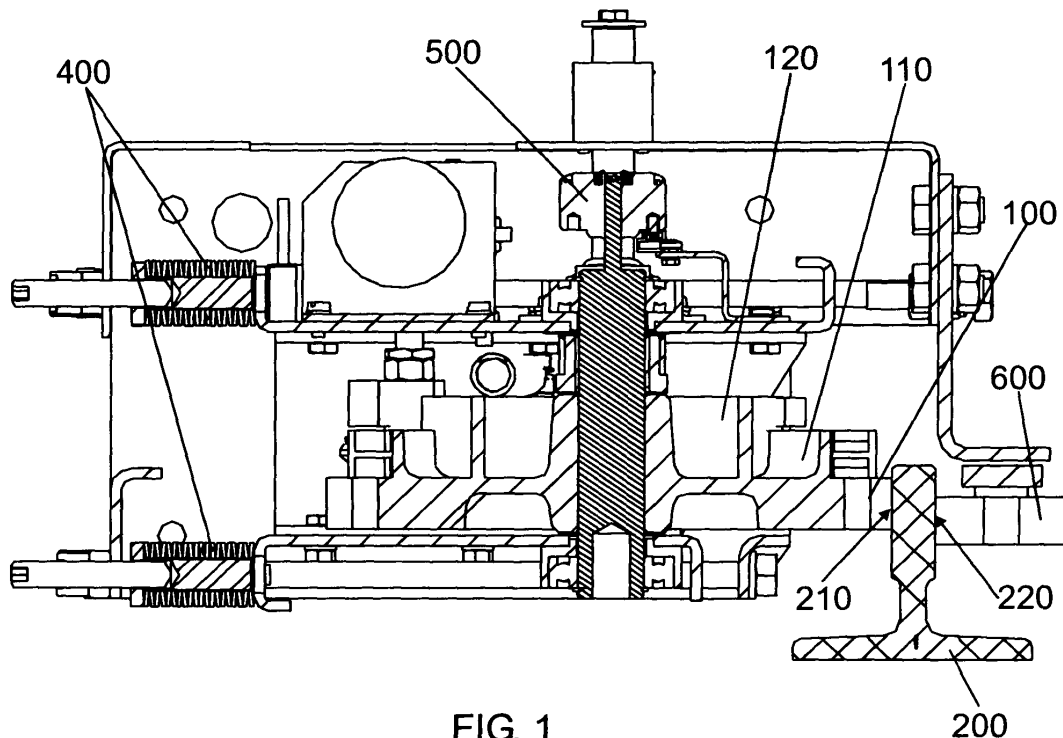

FIG. 1

EP 2 020 397 A1

Description

Field of the Invention

[0001] The invention consists of an apparatus and a system for detecting overspeed of a car, and/or a counterweight, for elevators, for actuating the emergency braking mechanism.

Background of the Invention

[0002] Different implementations are known in the state of the art for detecting elevator car overspeed.

[0003] Document ES 2 184 612 describes a speed limiting system for elevators, characterized in that it consists of a safety gear fixed to the elevator car and a moving part acting with the rail of the elevator; a crown wheel rotating with the rail of the elevator associated to a centrifugal speed governor; a link quadrangle in which the two opposite sides are joined to the moving part of the safety gear and to the crown wheel respectively; means tending to keep the safety gear in stand-by and means for keeping the crown wheel in contact with the rail of the elevator.

[0004] Document EP 475 114 describes a safety device and a centrifugal force speed governor for preventing overspeed conditions of an elevator car in both the downward direction and the upward direction. A bracket arranged in the elevator car incorporates a shaft at right angle to a guide rail arranged on the side wall. There is a U-shaped frame having a running wheel at the ends of the shaft of the sides of the wall. A telescopic compression spring extends over the shaft between the bracket and the frame to tense the shaft with an axial movement towards the side wall. As a result the running wheel is biased against the web of the guide rails. Each side of the running wheel has a pair of release levers acting on a locking wheel in the event of danger. In the release lever rotatably arranged on the running wheel there circulates, in normal car travel, each side of the running wheel around the stopped locking wheel, which is fixedly joined to a two-arm actuating lever. The movement of the actuating lever is transmitted on one hand to the release arm and on the other to the actuating bar, which is additionally in contact with the release arm that is opposite to the safety gear. The release arm circulating parallel to the guide rails is introduced in the wedge box of the safety gear. For resetting the safety device, the elevator car is restarted after a safety stop in the opposite direction of travel.

Description of the Invention

[0005] The present invention proposes an apparatus and a system that is independent of the safety gear system, that allows different types of actuations, is adaptable both to the upper part and to the lower part of the car and of the counterweight and does not necessarily have to

be arranged close to the counterweight.

[0006] According to a first aspect, the invention describes an apparatus for detecting the overspeed of elevator components selected from a car, a counterweight and combinations thereof, having:

a wheel, with an auxiliary surface configured to run on a first surface of a travel rail of the elevator component;

actuating means for actuating a braking mechanism of the elevator component characterized in that it comprises:

speed detecting means for generating a synchronized alternating movement with the speed of the elevator component;

the speed detecting means being configured to not generate the synchronized alternating movement when a predetermined speed of the car or the counterweight is exceeded and to thus activate the actuating means.

[0007] The speed detecting means comprise a ratchet mechanism comprising:

a polygonal-shaped cam in a side of the wheel, integral with said wheel;

a ratchet wheel in the same side of the wheel and also integral with said wheel, said ratchet wheel comprising a plurality of projections;

a rocker having a first end and a second end, provided with:

a follower at the first end for following the cam profile;

a ratchet at the second end for locking the ratchet wheel, thus locking the entire wheel.

[0008] Additionally, the apparatus may further comprise:

1) Positioning means formed by lock washers for pushing the auxiliary surface of the wheel against the rail and attempting to prevent the sliding of the wheel on the rail;

2) means of detecting the derailment and the variation in the pressure setting of the auxiliary surface of the wheel on the rail.

[0009] This pressure setting of the auxiliary wheel on the rail determines the generated friction force and the coefficient of friction between them.

[0010] The apparatus can also comprise slip monitoring means formed by an encoder configured to control when the auxiliary wheel slips by comparing a rotation speed of the auxiliary wheel with a travel speed of the elevator component.

[0011] Likewise, the apparatus may further comprise at least one roller configured to roll on a second surface

of the rail opposite to the first surface of the rail for:

Offsetting a stress exerted by the auxiliary wheel on the rail for preventing transmission of a reaction force on the elevator component;
Setting a pressure between the auxiliary wheel and the rail.

[0012] This roller can also be used for the operation of the apparatus with different rail thicknesses and for the operation with a rail having a different surface condition, such as a dry rail or a greased wheel.

[0013] In addition, the apparatus further comprises remote actuating means to voluntarily engage the ratchet mechanism.

[0014] According to a second aspect, the invention describes a system for detecting overspeed of elevator components selected from a car, a counterweight and combinations thereof, characterized in that it comprises at least one apparatus such as the one described above and transmission means joined to the actuating means for transmitting an actuating movement to the braking mechanism of the elevator component.

[0015] The system can incorporate the apparatus in an upper or lower part of the car or counterweight, the transmission means comprising in a first case an actuating assembly and first pinion and a second pinion, and the transmission means comprising in a second case a plurality of levers.

Brief Description of the Drawings

[0016] A series of drawings is described below which aid in better understanding the invention and which are expressly related to an embodiment of said invention presented as a non-limiting example thereof.

Figure 1 is a sectional plan view showing the apparatus of the invention and its arrangement as regards a rail of an elevator. Said Figure shows the wheel (100), the polygonal cam (110), the ratchet wheel (120), the lock washers (400), the rail (200), the roller (600) and the position of the encoder (500), which is located inside the apparatus.

Figure 2 shows a perspective view of the wheel, where the auxiliary surface of the wheel or auxiliary wheel (100), the polygonal cam (110) and the ratchet wheel (120) can be seen.

Figure 3 shows a perspective view of some components of the ratchet mechanism, such as the rocker (130), the follower (140), the ratchet (150) and the actuation of the braking system (300).

Figures 4A and 4B show two front and rear elevational views, respectively, where the rollers (600), the lock washers (400), the auxiliary wheel (100), the follower (140), the rocker (130), the position of the rail (200), the actuation (300), the coil (800) and the contacts (700) can be seen, said contacts being

in charge of detecting the derailment and the variation in the pressure setting of the auxiliary wheel on the rail.

Figure 5A shows a first configuration of the apparatus of the invention where the transmission means comprise a first pinion (310) and second pinion (920) actuating assembly, intended to transmit movement to the braking system by means of a chain or the like encircling the pinion.

Figure 5B shows a second configuration of the invention where the transmission means comprise a levering actuation (320) and a plurality of levers (910) transmitting movement to the braking system.

[0017] Both figures (5A and 5B) are perspective views of the apparatus of the invention with the two mentioned configurations.

Description of a Preferred Embodiment of the Invention

[0018] A preferred embodiment of the invention is described below with the aid of the figures.

[0019] The invention relates to an apparatus for detecting overspeed of elevator components selected from a car, a counterweight and combinations thereof, having:

A wheel, with an auxiliary surface (100) configured to run on a first surface (210) of a travel rail (200) of the elevator component;

Actuating means (300) for actuating a braking mechanism of the elevator component, characterized in that it comprises speed detecting means for generating a synchronized alternating movement with the speed of the elevator component;

[0020] The speed detecting means are configured to not generate the synchronized alternating movement when a predetermined speed of the elevator component is exceeded and to thus activate the actuating (300) means; the speed detecting means comprise a ratchet mechanism comprising:

A polygonal-shaped cam (110) on a side of the wheel (100), integral therewith.

A ratchet wheel (120) on the same side of the wheel (100) and also integral therewith, said ratchet wheel (120) comprising a plurality of projections;

A rocker (130) having a first end and a second end, provided with:

A follower (140) at the first end for following the cam profile (110);

A ratchet (150) at the second end for locking the ratchet wheel (120), thus locking the entire wheel (100).

[0021] According to a first preferred embodiment of the

invention, the apparatus further comprises:

Positioning means, formed by lock washers (400) for pushing the auxiliary surface of the wheel (100) against the first surface (210) of the rail (200) and attempting to prevent the sliding of said auxiliary surface of the wheel on the rail;

Means of detecting the derailment and the variation in a pressure setting of the auxiliary surface of the wheel (100) on the rail (200).

[0022] According to a second preferred embodiment of the invention, the apparatus further comprises slip monitoring means formed by an encoder (500) configured to control when the auxiliary wheel (100) slips by comparing a rotation speed of the auxiliary wheel (100) with a travel speed of the elevator component.

[0023] According to a third preferred embodiment of the invention, the apparatus further comprises at least one roller (600) configured to roll on a second surface (220) of the rail (200) opposite to the first surface (210) of the rail (200) for:

Offsetting a stress exerted by the auxiliary wheel (100) on the rail (200) for preventing a transmission of a reaction force on the elevator component;

Setting a pressure between the auxiliary wheel (100) and the rail (200).

[0024] According to a fourth preferred embodiment of the invention, the apparatus further comprises a remote actuating means or coil (800) for voluntarily engaging the ratchet (150).

[0025] Another embodiment of the invention relates to a system for detecting overspeed of an elevator component characterized in that it comprises at least one apparatus such as the one described above and transmission means joined to the actuating means (300) for transmitting an actuating movement to the braking mechanism of the elevator component.

[0026] In one configuration of the invention:

The apparatus is arranged in an upper part of the elevator component and the transmission means comprise a plurality of levers (910).

[0027] In another configuration of the invention:

The apparatus is arranged in a lower part of the elevator component and the transmission means comprise a first pinion (310) and second pinion (920) actuating assembly, which is intended to transmit movement to the braking system by means of a chain or the like encircling it.

Claims

1. An apparatus for detecting overspeed of elevator components selected from a car, a counterweight and combinations thereof, having:

an auxiliary wheel (100) configured to run on a first surface (210) of a travel rail (200) of the elevator component;

actuating means (300) for actuating a braking mechanism of the elevator component;

characterized in that:

it comprises speed detecting means for generating a synchronized alternating movement with the speed of the elevator component;

the speed detecting means are configured to not generate the synchronized alternating movement when a predetermined speed of the elevator component is exceeded and to thus activate the actuating (300) means;

the speed detecting means comprise a ratchet mechanism comprising:

a polygonal-shaped cam (110) on a first side of the auxiliary wheel (100) integral with said auxiliary wheel (100);

a ratchet wheel (120) on the first side of the auxiliary wheel (100) integral with said auxiliary wheel (100), said ratchet wheel (120) comprising a plurality of projections;

a rocker (130) having a first end and a second end, provided with:

a follower (140) at the first end for following the cam profile (110);

a ratchet (150) at the second end for locking the ratchet wheel (120) and thus locking the auxiliary wheel (100).

2. The apparatus of claim 1 **characterized in that** it further comprises:

positioning means, comprising a plurality of lock washers (400) for pushing the auxiliary wheel (100) against the first surface (210) of the rail (200) and preventing sliding of the auxiliary wheel (100) on the rail (200);

means for detecting derailment and variation in a pressure setting of the auxiliary wheel (100) on the rail (200).

3. The apparatus of any of claims 1-2 **characterized in that** it further comprises slip monitoring means formed by an encoder (500) configured to control when the auxiliary wheel (100) slips by comparing a rotation speed of the auxiliary wheel (100) with a

travel speed of the elevator component.

4. The apparatus of any of claims 1-3 **characterized in that** it further comprises at least one roller (600) configured to roll on a second surface (220) of the rail (200) opposite to the first surface (210) of the rail (200) for:
- offsetting a stress exerted by the auxiliary wheel (100) on the rail (200) for preventing transmission of a reaction force on the elevator component;
- setting a pressure between the auxiliary wheel (100) and the rail (200).
- 5.
5. The apparatus of any of claims 1-4 **characterized in that** it further comprises remote actuating means or coil (800) for engaging the ratchet (150) voluntarily.
- 20
6. A system for detecting overspeed of elevator components selected from a car, a counterweight and combinations thereof, **characterized in that** it comprises at least one apparatus according to any of claims 1-6 and transmission means joined to the actuating means (300) for transmitting an actuating movement to the braking mechanism of the elevator component.
- 25
7. The system of claim 6, arranged in an upper part of the elevator component, **characterized in that** the transmission means for transmitting the actuating movement to the braking mechanism comprise a plurality of levers (910).
- 30
- 35
8. The system of claim 6, arranged in a lower part of the elevator component, **characterized in that** the transmission means for transmitting the actuating movement to the braking mechanism comprise a first pinion (310) and second pinion (920) actuating assembly, where second pinion (920) is configured to transmit movement to the braking system by means of a chain meshing in said second pinion (920).
- 40
- 45
- 50
- 55

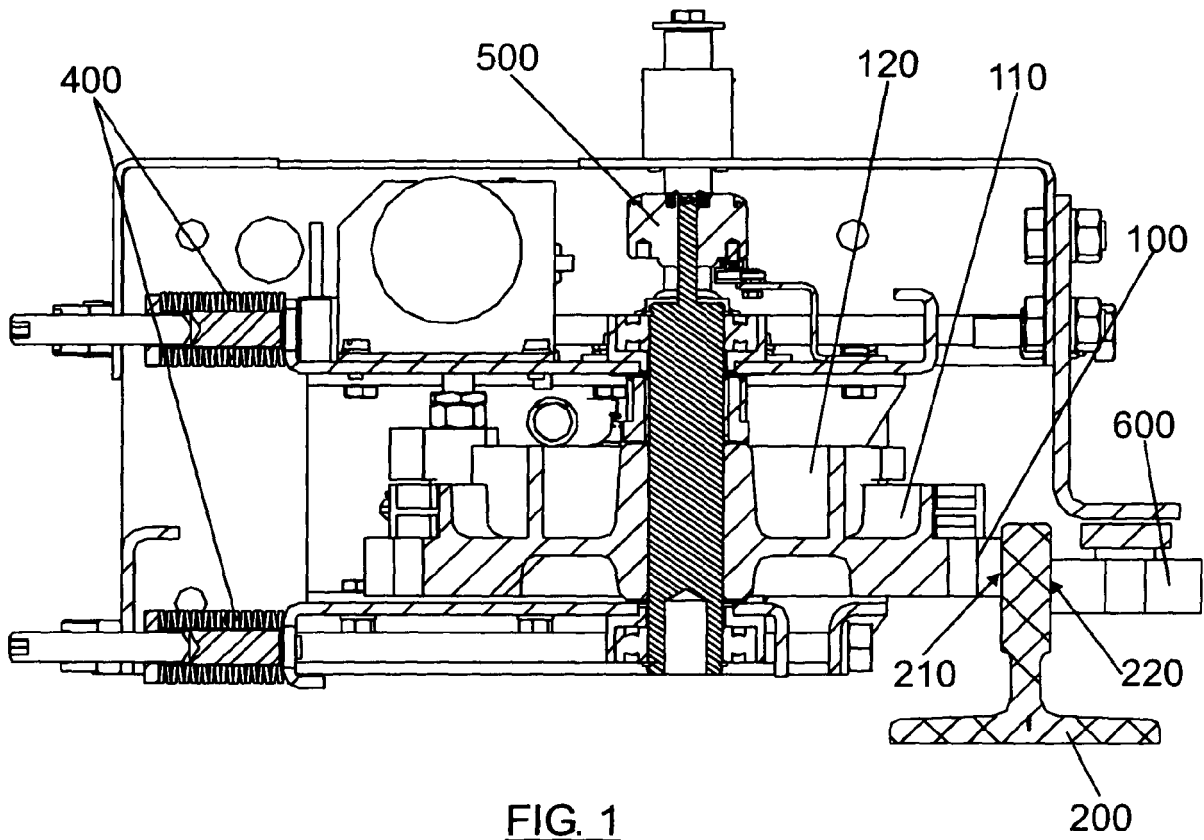

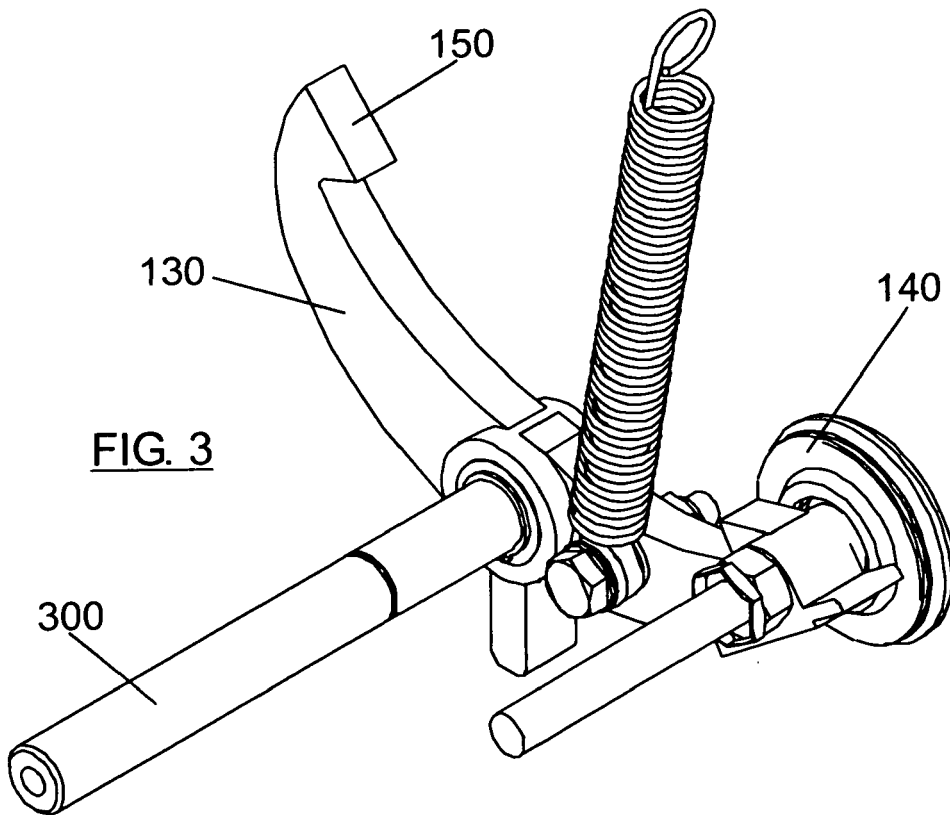
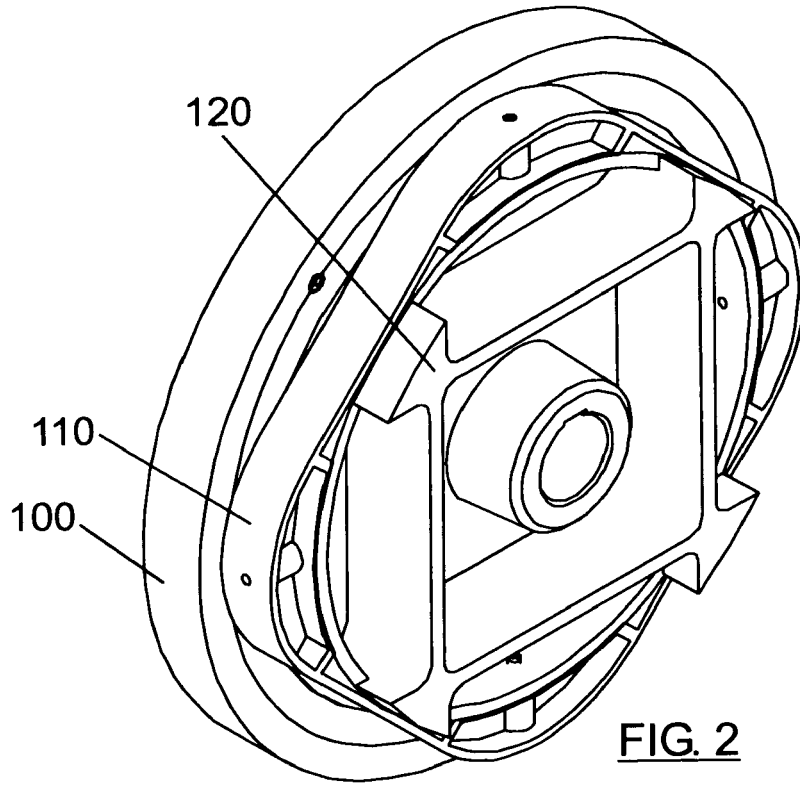

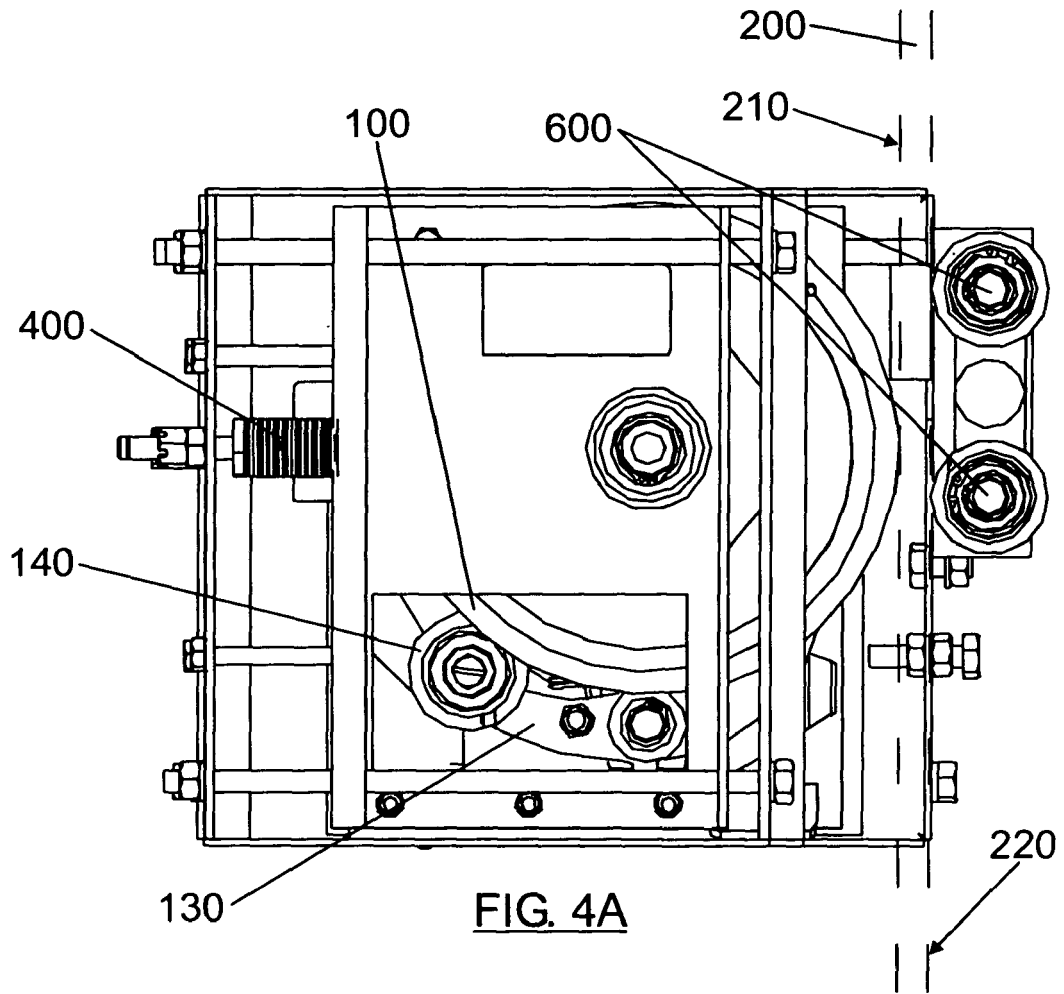
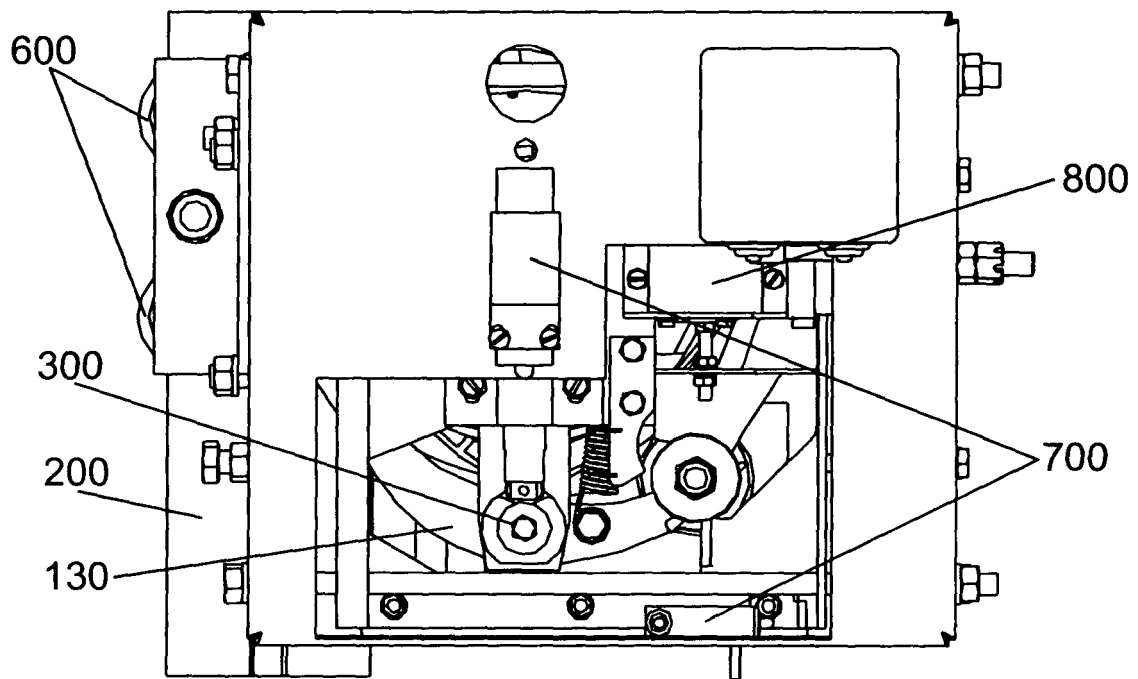
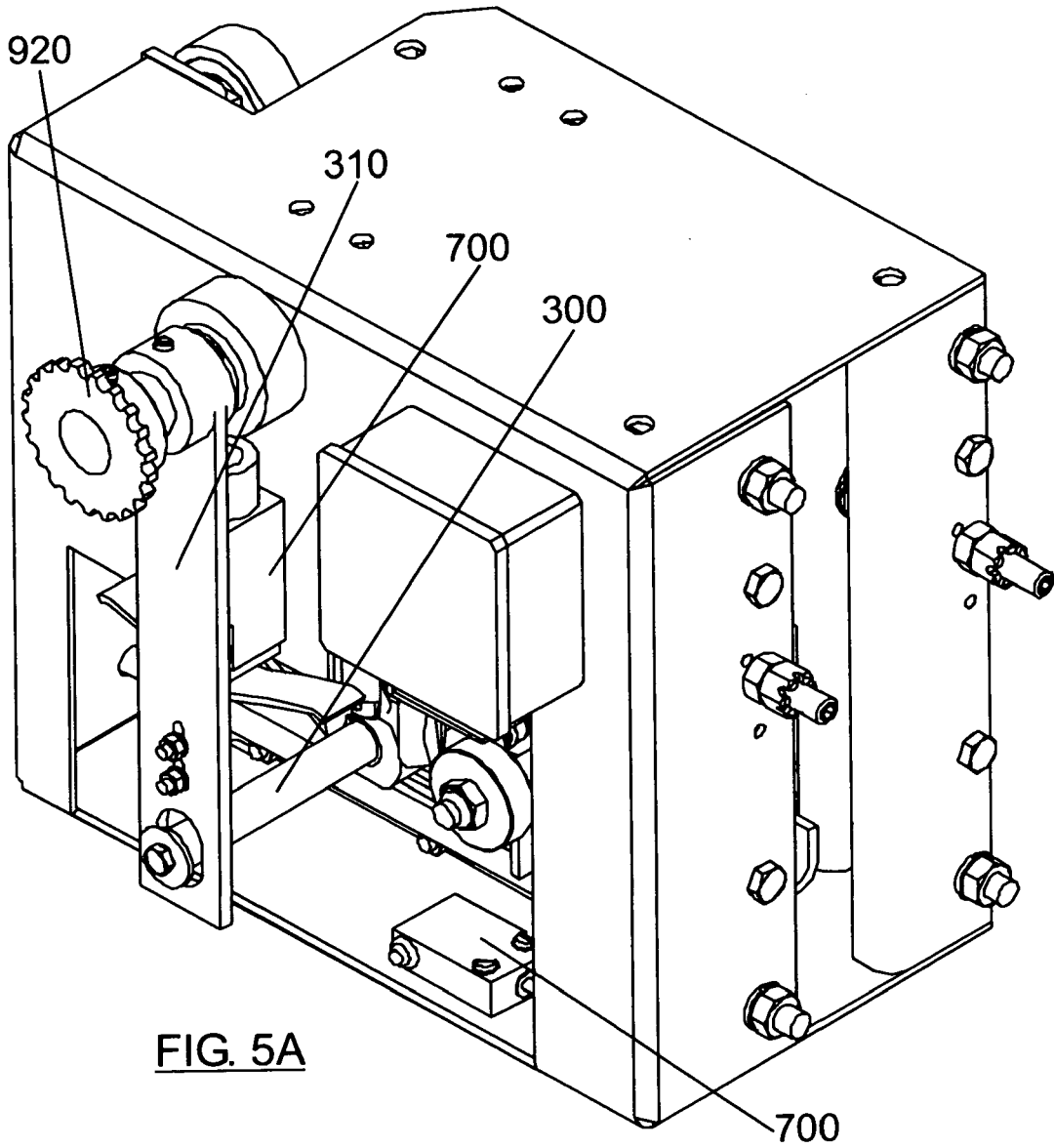

FIG. 4B





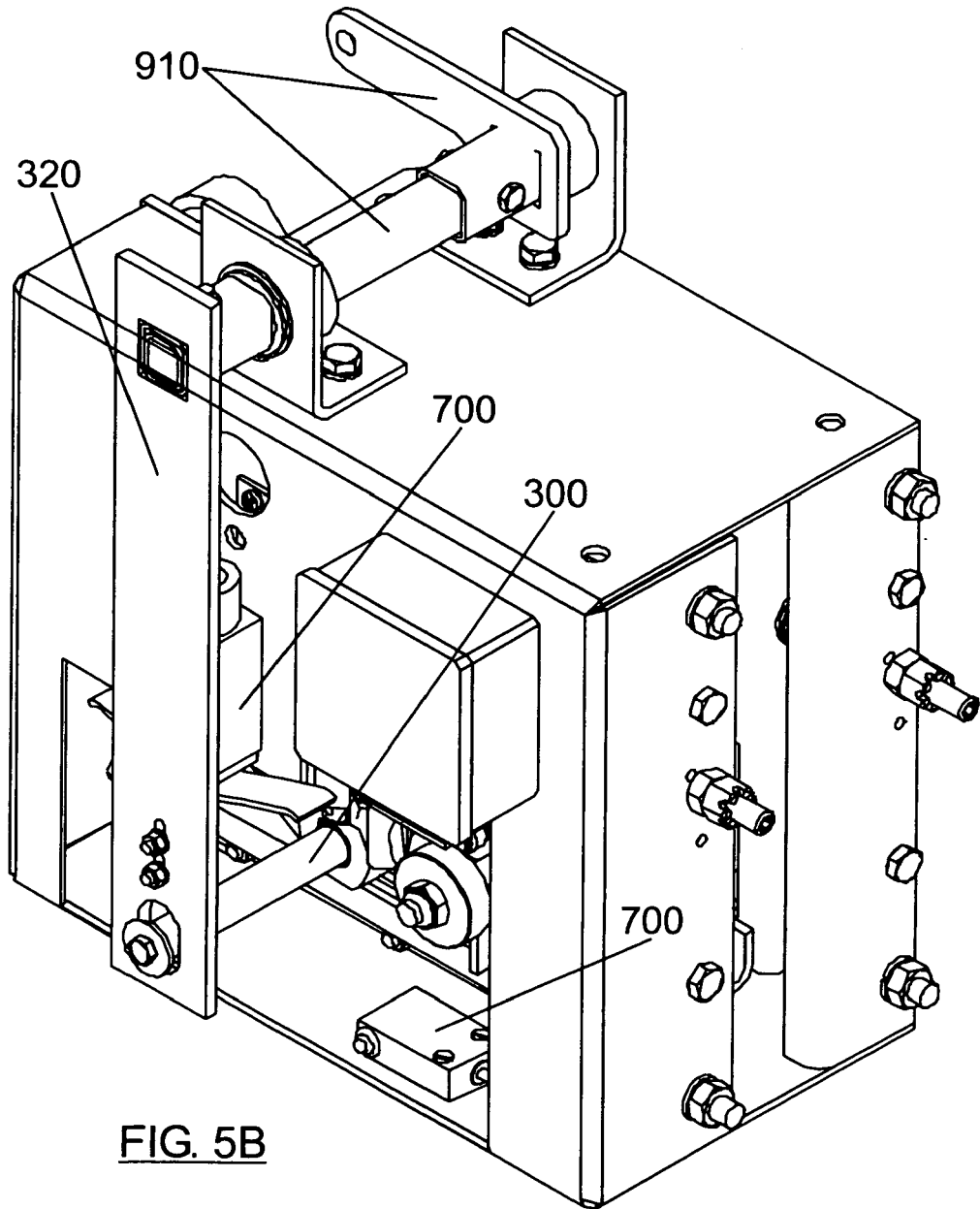

FIG. 5B



DOCUMENTS CONSIDERED TO BE RELEVANT			
Category	Citation of document with indication, where appropriate, of relevant passages	Relevant to claim	CLASSIFICATION OF THE APPLICATION (IPC)
X	DE 101 47 629 A1 (SCHLOSSER GERHARD [DE]) 24 April 2003 (2003-04-24) * the whole document *	1,4,6-8	INV. B66B5/04
Y	-----	5	
X	EP 1 516 842 A (AUFZUGEVOLUTION SCHLOSSER & SC [DE]) 23 March 2005 (2005-03-23) * abstract * * paragraph [0024] - paragraph [0036] * * figures 1,2 *	1,4,6-8	
Y	-----	5	
X	EP 0 121 711 A (BONGERS & DEIMANN [DE]) 17 October 1984 (1984-10-17) * abstract * * page 5, line 26 - page 6, line 27 * * claim 10 * * figures 1,2 *	1,4-8	
X	DE 28 57 376 C2 (THYSSEN AUFZUEGE GMBH, 7303 NEUHAUSEN, DE) 1 October 1981 (1981-10-01) * abstract * * column 4, line 25 - column 7, line 30 * * figures 1-3 *	1,4,6-8	
			TECHNICAL FIELDS SEARCHED (IPC)
			B66B
Y	-----	5	
D,A	US 5 065 845 A (PEARSON DAVID B [US]) 19 November 1991 (1991-11-19) * abstract * * column 2, line 67 - column 4, line 16 * * figures 1-4 *	1	

The present search report has been drawn up for all claims			
Place of search		Date of completion of the search	Examiner
The Hague		14 December 2007	Oosterom, Marcel
CATEGORY OF CITED DOCUMENTS			
X : particularly relevant if taken alone Y : particularly relevant if combined with another document of the same category A : technological background O : non-written disclosure P : intermediate document		T : theory or principle underlying the invention E : earlier patent document, but published on, or after the filing date D : document cited in the application L : document cited for other reasons & : member of the same patent family, corresponding document	

EPO FORM 1503 03/82 (P04C01)

**ANNEX TO THE EUROPEAN SEARCH REPORT
ON EUROPEAN PATENT APPLICATION NO.**

EP 07 38 0228

This annex lists the patent family members relating to the patent documents cited in the above-mentioned European search report. The members are as contained in the European Patent Office EDP file on
The European Patent Office is in no way liable for these particulars which are merely given for the purpose of information.

14-12-2007

Patent document cited in search report	Publication date	Patent family member(s)	Publication date
DE 10147629 A1	24-04-2003	NONE	
EP 1516842 A	23-03-2005	DE 10343193 A1	21-04-2005
EP 0121711 A	17-10-1984	NONE	
DE 2857376 C2	01-10-1981	NONE	
US 5065845 A	19-11-1991	AT 136001 T	15-04-1996
		AU 638866 B2	08-07-1993
		AU 8381791 A	19-03-1992
		BR 9103946 A	26-05-1992
		CA 2049510 A1	14-03-1992
		CN 1061945 A	17-06-1992
		DE 59107609 D1	02-05-1996
		DK 475114 T3	08-07-1996
		EP 0475114 A1	18-03-1992
		ES 2087934 T3	01-08-1996
		FI 914211 A	14-03-1992
		HK 85997 A	27-06-1997
		HU 59642 A2	29-06-1992
		JP 2863354 B2	03-03-1999
		JP 4246079 A	02-09-1992
		MX 9101017 A1	04-05-1992
		NO 913556 A	16-03-1992
		ZA 9106773 A	27-05-1992

REFERENCES CITED IN THE DESCRIPTION

This list of references cited by the applicant is for the reader's convenience only. It does not form part of the European patent document. Even though great care has been taken in compiling the references, errors or omissions cannot be excluded and the EPO disclaims all liability in this regard.

Patent documents cited in the description

- ES 2184612 [0003]
- EP 475114 A [0004]