

D. J. JONES.

Improvement in Machines for Rolling Metals.

No. 131,005.

Patented Sep. 3, 1872.

*Fig. 1*

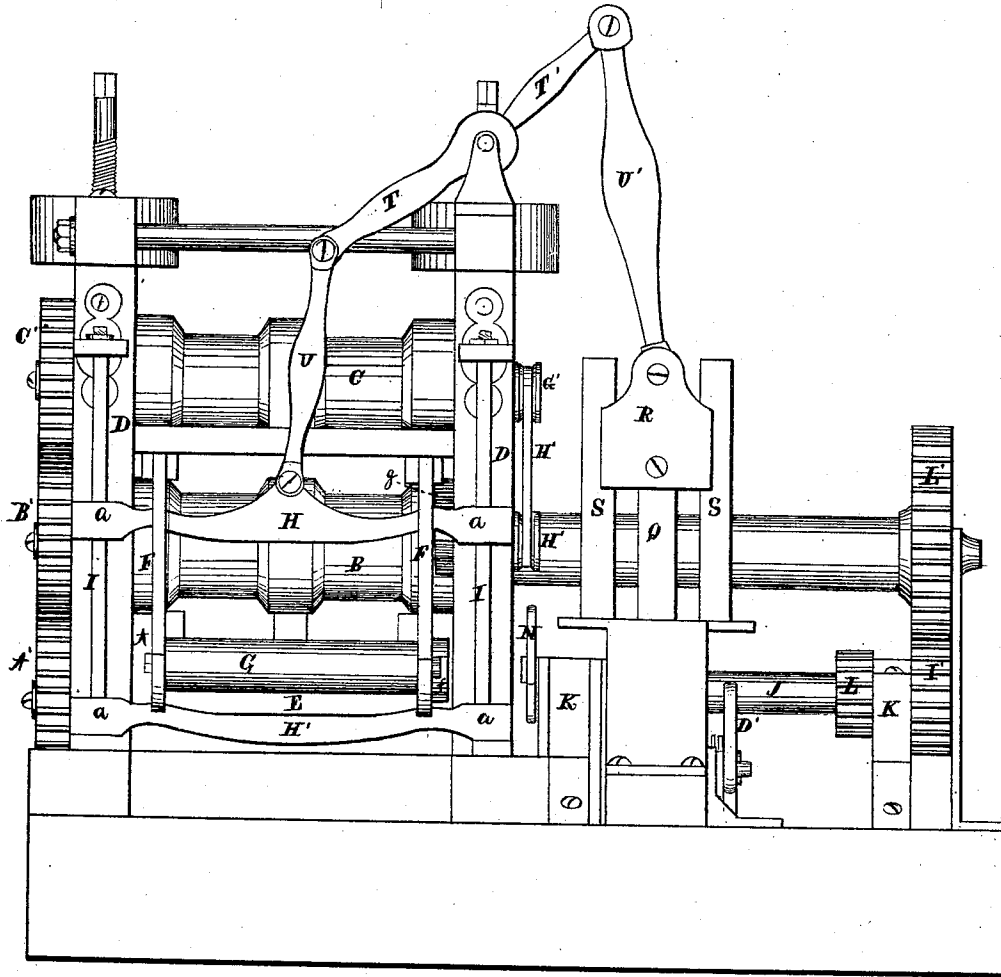

**Witnesses**  
*A. W. Decker*  
*A. F. Cornell.*

**Inventor**  
*David J. Jones.*  
*Per. Burridge & Co.*  
*Attys.*

D. J. JONES.

Improvement in Machines for Rolling Metals.

No. 131,005.

Patented Sep. 3, 1872.

*Fig. 2*

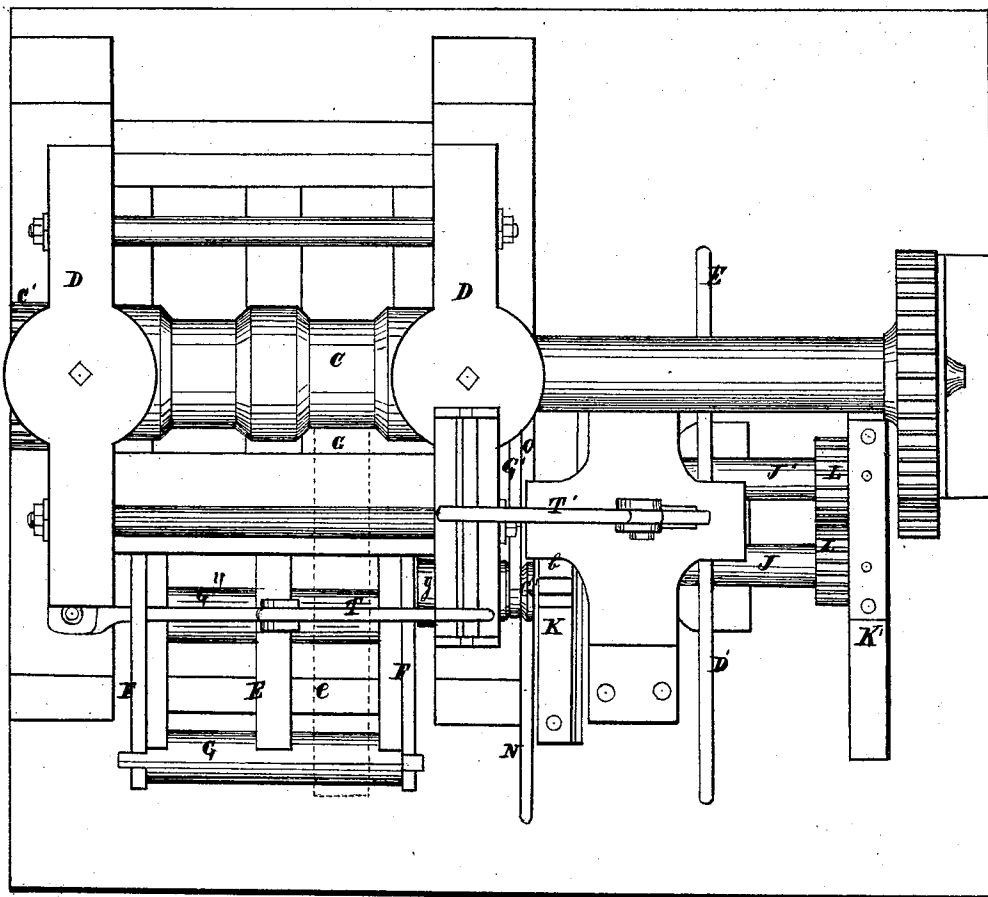

**Witnesses**

*A. W. Decker*  
*A. F. Cornell.*

**Inventor**

*David J. Jones.*  
*Per. Burridge & Co.*  
*Attns.*

D. J. JONES.

Improvement in Machines for Rolling Metals.

No. 131,005.

Patented Sep. 3, 1872.

*Fig. 3*

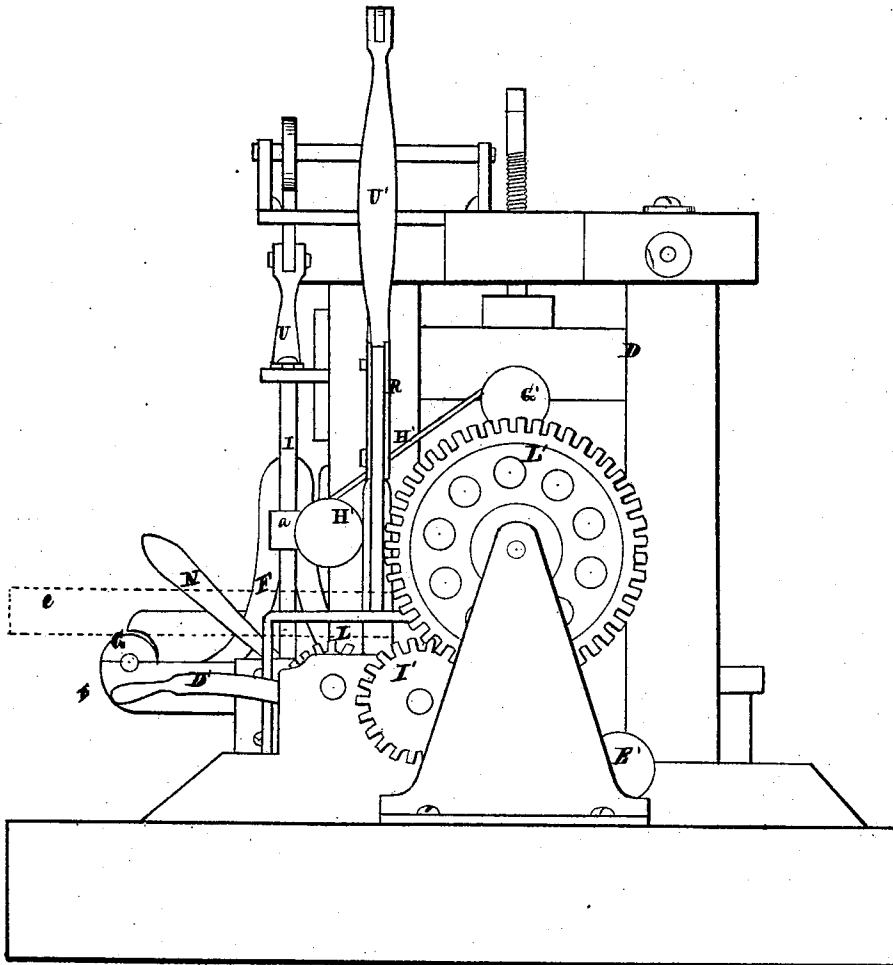

**Witnesses**  
*A. W. Decker*  
*A. F. Cornell.*

**Inventor**  
*David J. Jones.*  
*Per. Burridge & Co.*  
*Atty's.*

D. J. JONES.

Improvement in Machines for Rolling Metals.

No. 131,005.

Patented Sep. 3, 1872.

Fig. 4

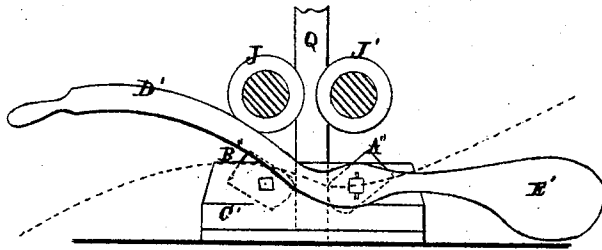

Fig. 5

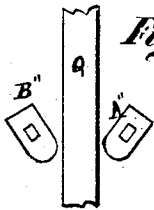

Fig. 7



Fig. 6

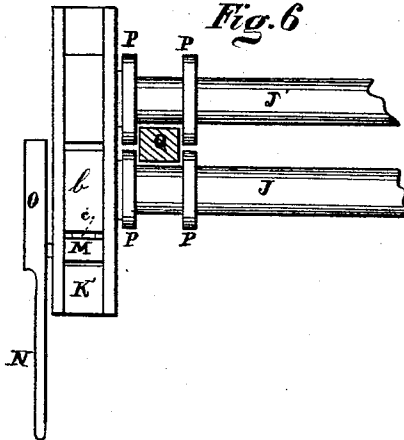
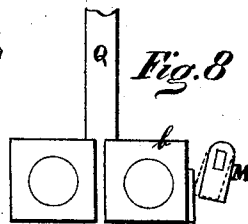

Fig. 8



Witnesses

A. W. Decker  
A. F. Cornell.

Inventor

David J. Jones.  
Per. Burridge & Co.  
Atty's.

# UNITED STATES PATENT OFFICE.

DAVID I. JONES, OF NEWBURG, OHIO.

## IMPROVEMENT IN MACHINES FOR ROLLING METALS.

Specification forming part of Letters Patent No. 131,005, dated September 3, 1872.

To all whom it may concern:

Be it known that I, DAVID I. JONES, of Newburg, in the county of Cuyahoga and State of Ohio, have invented a certain new and Improved Machine for Rolling Iron and Steel; and I do hereby declare that the following is a full, clear, and complete description thereof, reference being had to the accompanying drawing making part of the same.

Figure 1 is a side elevation of the machine. Fig. 2 is a plan view. Fig. 3 is an end elevation. Figs. 4, 5, 6, 7, and 8 are detached sections, to which reference will be made.

Like letters of reference refer to like parts in the several views.

### SPECIFICATION.

The nature of this invention relates to a certain device attached to an iron-rolling machine having a gang of three rollers or more; and the object thereof is to elevate or lower the billet or pile, thereby bringing it into proper position for being passed between the rolls, by which device is saved the hand labor and the attention of a number of the hands usually employed for that purpose.

Of the above said device the following is a more full and complete description:

In the drawing, A B C represent the rollers, which are arranged one above the other, as shown, and secured in the housings D in the usual way, and made to revolve by the gearing A' B' C'. In front of the rollers is arranged an elevator, E, Fig. 2, consisting of the sides F, Fig. 3, having journaled transversely therein rollers G. On the upper and lower side of the elevator is a cross-head, H H', Fig. 1, the ends of which project beyond the sides thereof, forming guides *a*, through which pass the rods I, whereby the said elevator is supported and guided in its vertical movements. The upward movement of the elevator is obtained by the friction-rollers J J', Fig. 2, a detached view of which is shown in Fig. 6. Said rollers are journaled in the stays K K', and are made to engage each other by means of the pinions L. The journal-boxes of the roller J' are fixed in the stays, whereas the journal-box *b*, Figs. 2 and 6, of the roller J, is adjustable in the stay, so that it can be moved either toward or away from the stationary box of the roller J', by means of a lug, M, Fig. 8, pivoted in

the cheeks of the stay, as shown in Fig. 6, and which is operated for moving it toward the stationary box by the lever N attached to the projecting end of the journal of the lug, which, on depressing the projecting end of the lever, throws the lug against the box, thereby forcing it toward the stationary one, but which immediately recedes therefrom on releasing the lever, the counter-balance or weight O on the opposite end of the lever causing the lug to drop away from the box and permit the box to move away from the stationary box. In order to keep the lug in constant contact with the box, and to prevent it from moving too far back, a piece of rubber, *c*, is interposed between the lug and box, which causes a slight pressure to be exerted on the box, but not of sufficient force to move it. It will be observed that on each of the rollers J is a pair of collars, P, Fig. 6, between which is inserted the wooden shaft Q, Fig. 1, which is of sufficient thickness to be pressed by the two rollers, on moving forward the movable box of roller J without permitting the faces of the collars to touch. The upper end of the shaft is attached to a cross-head, R, Fig. 1, secured between the guides S, in which the head slides, for a purpose presently shown. The cross-head and shaft referred to are connected to the elevator E above described by the interposition of the arms T T' and the pitman U U', as shown in Fig. 1. Immediately below the collared section of the rollers is arranged a clamp, consisting of the lugs A' B', Figs. 4 and 5, which represent detached sections thereof. Between said lugs descends the lower end of the shaft Q, as shown in Fig. 4. Said lugs are pivoted in a frame or box, C', arranged for that purpose. To one of the lugs is attached the lever D' in a rigid manner, whereas the other lug is attached thereto by a link, *d*, Fig. 7, secured rigidly to the lug and pivoted to a similar link, *d'*, also attached to the lug to which the lever is connected. By this attachment of the lugs to the lever they are both operated simultaneously on working the lever. On one end of said lever is a weight, E', whereby the opposite end is thrown upward, thereby causing the two lugs to embrace the sides of the shaft Q, between which it descends from between the collars of the rolls J J', as shown in Fig. 4, which represents a detached section

of the machine, or so much thereof as shows the rolls J J' and the clamping device above described. *f*, Fig. 1, is a friction-roller journaled in the side of the housing, and is made to revolve by a pulley and belt, H' H', and a pulley, G', secured to the end of the upper roll C. The purpose of said friction-roller will hereinafter be shown.

Having described the construction and arrangement of the machine, the practical operation of the same is as follows: As aforesaid, the above-described invention is for the purpose of raising the billet or ingot of metal from the lower passes of the rollers to the rollers above, and for lowering the same from the higher passes to the lower ones, thereby saving the lifting of the metal by the bodily strength of the workmen. The relative position of the elevator to the lower rollers is such as to permit the billet to pass between them; and in order to do which it is laid upon the elevator on the rollers G, as indicated by the dotted lines *e*, Figs. 2 and 3. The passes are now made in the usual way, from the front to the back of the rolls, and from thence through to the front again. In order to bring the now partially-rolled billet in position to pass through the upper and middle rolls the elevator is raised up from the position shown in Fig. 1 so far as to bring the iron in range of the rolls, which is done by pressing down upon the end of the lever N, thereby forcing the movable box *b* toward the fixed one, thus bringing the roller J, or that part thereof between the collars P, forcibly against the side of the shaft Q, which the revolving rollers will draw down, thereby raising the elevator to the desired height to allow the iron thereon to pass through the rollers, which it will do by being carried forward to the rollers by the middle roller G'' of the elevator, and upon which rollers the iron rests. Said roller G'', at this time, is made to revolve for carrying forward the iron by means of the friction-rollers *f*, Fig. 1, secured to the outer end of said middle roller G'', which, in consequence of the lifting up of the elevator, is caused to impinge upon the roller *g*, driven by the pulley H'. The contact of the friction-roller *f* with the friction-roller *g* rotates the roller on which the iron lies, and which is thereby carried forward into the rolls. The elevator is retained in its relation to the middle and upper rolls by the lugs A'' B'', the lower sides of which are kept in constant contact with the sides of the shaft Q by the weight E' of the end of the lever D', to which the lugs are attached, as above described. This contact of the lugs with the shaft, while it permits the shaft to descend between them for

raising the elevator, will not allow it to ascend, as the tendency of the lugs is to draw hard against the shaft, and thereby prevent its ascent, but which will hold it securely at any one particular height. In order to cause the shaft to ascend, to effect the descent of the elevator, the lugs are thrown back from their contact with the shaft, by depressing the end of the lever D', the effect of which will be to move back the two lugs from their contact with the shaft, as shown in Fig. 5. The weight of the elevator will cause itself to descend when thus released from the clamping contact of the lugs to the position shown in Fig. 1, to be again used as a table and guide, on which to lay another billet or pile for being passed through the rollers—the lower and middle one—which, when done, the elevator is again raised by depressing the end of the lever N, thereby forcing the rollers J J' hard against the shaft Q, which will thereby be drawn down as and for the purpose above said, the two rollers being operated by the cog-wheels I' and L', Fig. 3, whereby the rollers are kept in motion all the time for raising the elevator.

As aforesaid, the above-described device saves much of the heavy lifting heretofore required to bring the iron in position for passing through the rollers, and also dispenses with the use of several hands usually necessary to run a set of rolls in the ordinary way.

An elevator of the same construction and operated in the same way can be or should be arranged on both sides of the rolls.

The elevator above described can be applied to, and operated in combination with, a three or more high roll-mill.

#### Claims.

What I claim as my invention, and desire to secure by Letters Patent, is—

1. The elevator E, consisting of the sides F, rollers G G'', cross-head H H', guides *a*, and friction-roller *f*, constructed and arranged in relation to the rollers A B C and roller *g* to cooperate therewith in the manner described, and for the purpose set forth.

2. The rollers J J', cross-head R, guide S, shaft Q, pitman U U', and arms T T', in combination with the elevator E, in the manner as and for the purpose set forth.

3. The lugs A'' B'', links *d d'*, and lever D', as arranged in combination with the shaft Q, substantially as and for the purpose specified.

DAVID I. JONES.

Witnesses:

W. H. BURRIDGE,  
JOHN H. BURRIDGE.