



US 20170121881A1

(19) **United States**

(12) **Patent Application Publication**
YANG et al.

(10) **Pub. No.: US 2017/0121881 A1**

(43) **Pub. Date: May 4, 2017**

(54) **A METHOD FOR DETECTING IMBALANCE OF WASHING MACHINE, AND A WASHING MACHINE**

D06F 39/00 (2006.01)

D06F 25/00 (2006.01)

D06F 37/30 (2006.01)

D06F 37/36 (2006.01)

(71) Applicant: **QINGDAO HAIER WASHING MACHINE CO.,LTD.**, Laoshan, Qingdao (CN)

D06F 37/24 (2006.01)

D06F 39/14 (2006.01)

(72) Inventors: **Lin YANG**, Laoshan, Qingdao (CN); **Qiuying GAO**, Laoshan, Qingdao (CN); **Dafeng FANG**, Laoshan, Qingdao (CN); **Wenting XU**, Laoshan, Qingdao (CN)

(52) **U.S. Cl.**

CPC *D06F 37/203* (2013.01); *D06F 37/24*

(2013.01); *D06F 33/02* (2013.01); *D06F*

39/14 (2013.01); *D06F 25/00* (2013.01);

D06F 37/304 (2013.01); *D06F 37/36*

(2013.01); *D06F 39/005* (2013.01)

(73) Assignee: **QINGDAO HAIER WASHING MACHINE CO.,LTD.**, Laoshan, Qingdao (CN)

(57)

ABSTRACT

(21) Appl. No.: **15/318,778**

(22) PCT Filed: **Jul. 2, 2014**

(86) PCT No.: **PCT/CN2014/081462**

§ 371 (c)(1),

(2) Date: **Dec. 14, 2016**

(30) **Foreign Application Priority Data**

Jun. 16, 2014 (CN) 201410266859.7

Jun. 16, 2014 (CN) 201410267444.1

Publication Classification

(51) **Int. Cl.**

D06F 37/20 (2006.01)

D06F 33/02 (2006.01)

A washing machine and method for detecting imbalance of the washing machine, comprising the following steps: running a dehydration process, and performing an eccentricity detection action in a test dehydration process performing eccentricity detection test dehydration action; a sensor module performing a eccentricity detection action to detect the eccentricity of a machine in real time, and setting a preliminary dehydration curve; when running a low-speed drain, the sensor module detects the low-speed eccentricity in real time; determining whether the detected low-speed eccentricity exceeds a set value; if yes, then correcting the low-speed eccentricity, and if not, then proceeding to the next step; when running a high-speed drain, the sensor module detects a high-speed eccentricity in real time; determining whether the high-speed eccentricity of the high-speed drain exceeds a set value; if yes, then correcting the high-speed eccentricity, and if not, then ending with a high-speed draining.

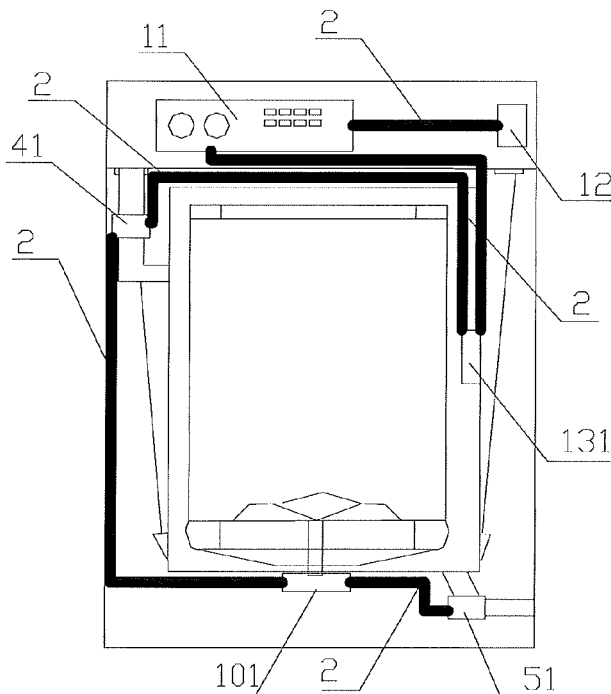

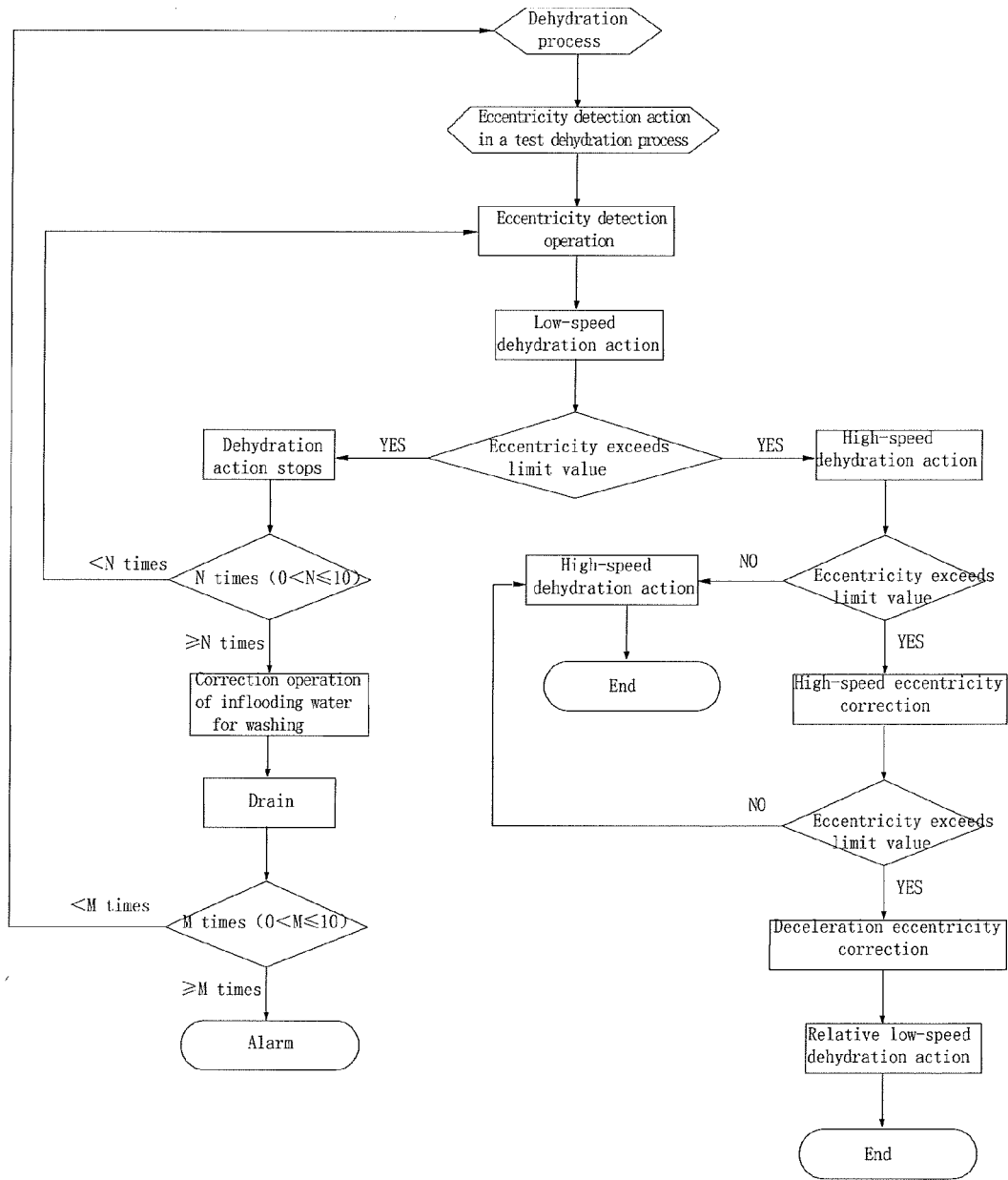

Fig. 1

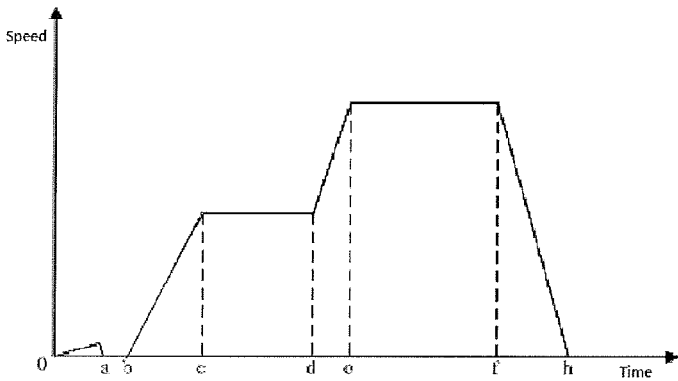

Fig. 2

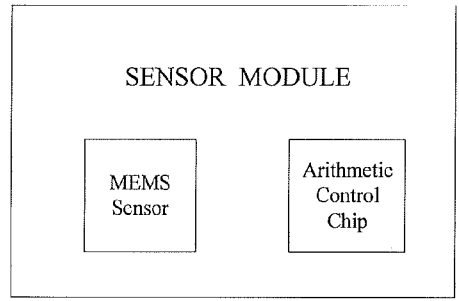

Fig. 3

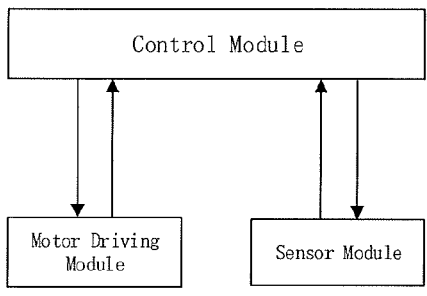

Fig.4

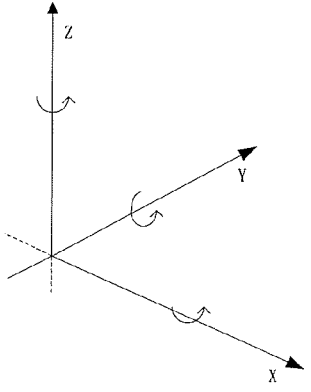

Fig. 5

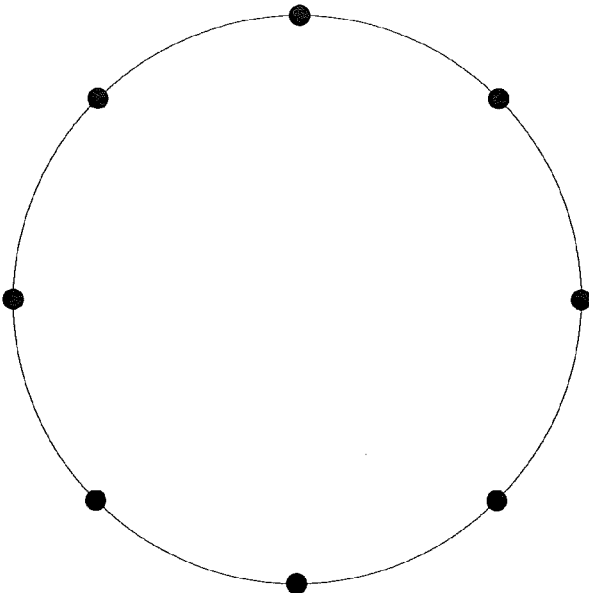

Fig. 6

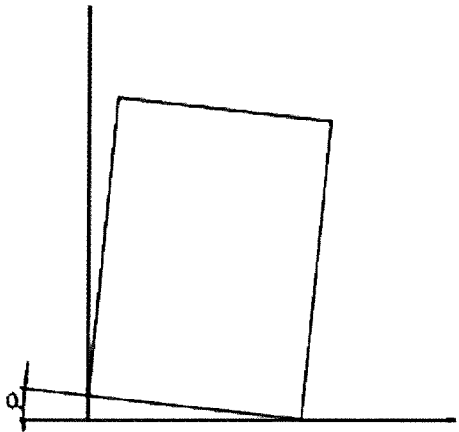

Fig. 7

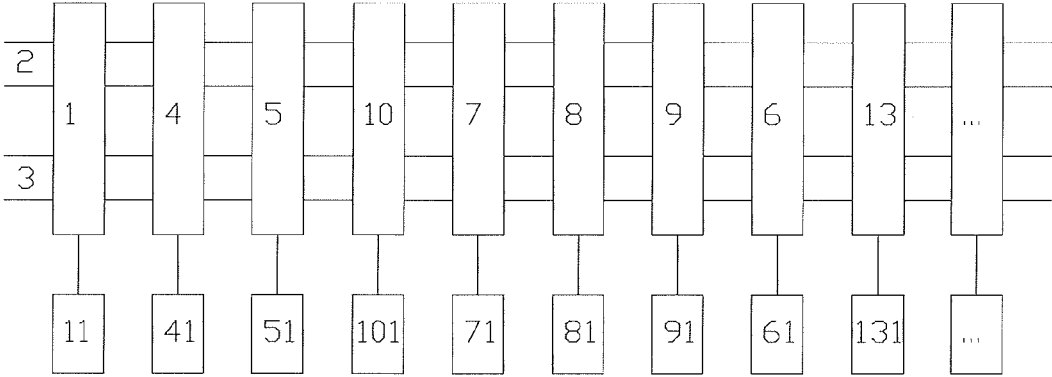

Fig. 8

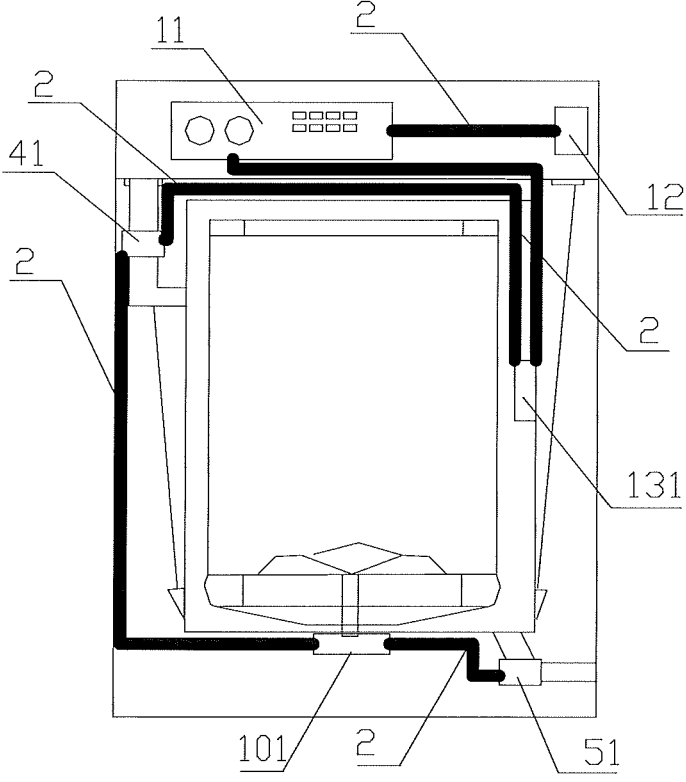

Fig. 9

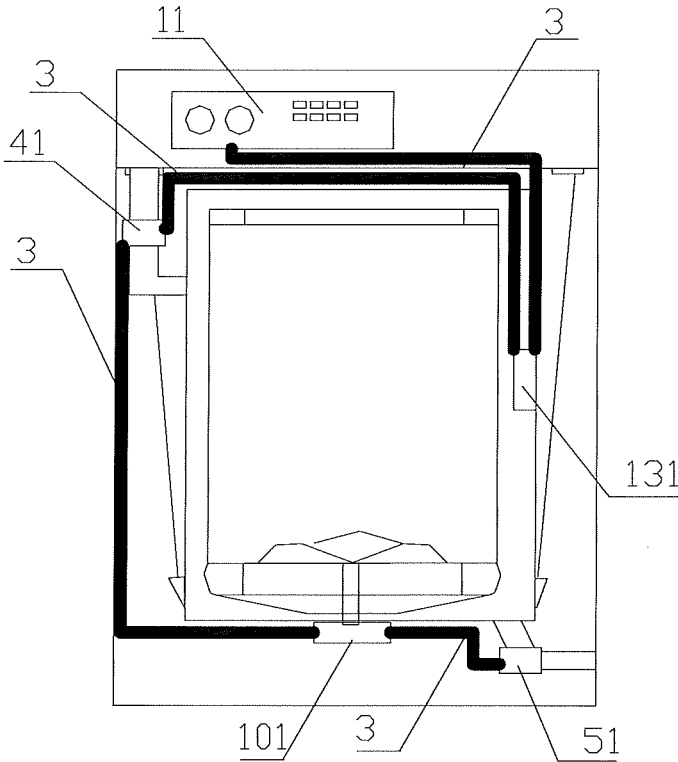

Fig. 10

A METHOD FOR DETECTING IMBALANCE OF WASHING MACHINE, AND A WASHING MACHINE

FIELD OF THE INVENTION

[0001] The present invention relates to the field of washing machines, and more particularly, to a method for detecting imbalance of washing machine and a washing machine.

BACKGROUND OF THE INVENTION

[0002] Washing machines are very popular among users for freeing people from the laundry work as a daily household appliance. A washing machine mainly comprising a casing, an outer tub, an inner tub, an agitator, a motor and a printed circuit board, the agitator is inside the inner tub, the inner tub is inside the outer tub, the outer tub is suspended from the casing by a boom, the printed circuit board controls the motor to perform rinsing and spinning. When the clothes are rinsed, the washing machine goes on spinning process. The spinning way of the prior auto agitator washing machine is that the loads are driven by the inner tub to spin the water out through the centrifugal force. When the loads are not evenly distributed, the washing machine easily vibrates, the outer tub is easily thumping the sides of the casing and the washing machine shifts in severe situation. It will affect the quietness of the operating washing machine and the service time of the motor and mechanical structure of the washing machine.

[0003] The existing auto washing machine avoiding the “jumps and bangs” phenomenon by hitting the anti-collision bar to trigger the safety switch when imbalanced spinning. However, there are several shortcomings as follows: firstly, when the eccentricity is too large the outer tub will thump the casing when turn off the washing machine due to inertia; secondly, the anti-collision bar is fixedly mounted on a position, the outer tub may thump the casing without triggering the safety switch and the anti-collision bar can't detect the thumping problem to avoid vibration; thirdly, due to the strong randomness of the thump, there may be eccentricity of the outer tub but no thump to the safety switch. This will result in “misleading”, so that the washing machine will continue to spin and continue to thump the casing, this will lead to the occurrence of displacement or damage of the washing machine, reducing the service life of the washing machine.

[0004] In order to achieve the goal of balancing the machine, part of the existing washing machines using photosensors to calculate the acceleration by measuring the rotational speed, but the balance of the washing machine can't be precisely controlled. At some eccentricities, the outer tub is easily thumping the casing at the beginning stage of spinning, it needs several calculations to find the appropriate drain curve.

[0005] Therefore, how to realize the real-time eccentricity detection of the washing machine in the spinning, and real-time control based on the detection result becomes an urgent problem to be solved.

SUMMARY OF THE INVENTION

[0006] The object of the present disclosure is to provide a method for detecting imbalance of a pulsator washing machine, which is capable of actively and real-timely per-

forming eccentricity detection and performing real-time correction based on the detection result.

[0007] In order to achieve the object above, the present disclosure adopts following technical scheme:

[0008] A method for detecting imbalance of a washing machine comprises the following steps:

[0009] S1. Running a dehydration process and performing an eccentricity detection action in a test dehydration process;

[0010] S2. A sensor module performing an eccentricity detection operation to detect an eccentricity state of the washing machine in real-time and setting a preliminary dehydration curve;

[0011] S3. Performing a low-speed dehydration action in accordance with the dehydration curve, and the sensor module detecting a low-speed eccentricity in real time;

[0012] S4. Determining whether or not the detected low-speed eccentricity exceeds a limit value;

[0013] S5. If the determination result is YES, executing a low-speed eccentricity correcting operation, and if the determination result is NO, proceeding to the next step;

[0014] S6. Performing a high-speed dehydration action, and the sensor module detecting a high-speed eccentricity in real time;

[0015] S7. Determining whether or not the detected high-speed eccentricity exceeds a limit value;

[0016] S8. If the determination result is YES, executing a high-speed eccentricity correcting operation, and if the determination result is NO, ending with the high-speed dehydration action.

[0017] Further, the low-speed eccentricity correcting operation in S5 comprises following steps:

[0018] S51. Stopping the low-speed dehydration action;

[0019] S52. Correcting the dehydration curve;

[0020] S53. Performing the low-speed dehydration action in accordance with the corrected dehydration curve and backing to S3.

[0021] Further, the low-speed eccentricity correcting operation is executed up to N times in S5, wherein, the N satisfies: $0 < N \leq 10$.

[0022] Further, when the low-speed eccentricity correcting operation is executed more than N times in S5, following steps are executed:

[0023] S54. Performing a correction action of inflooding water for washing;

[0024] S55. Executing a drain operation;

[0025] S56. Backing to S1.

[0026] Further, S54 is executed up to M times, wherein, the M satisfies: $0 < M \leq 10$, if S54 is executed more than M times, an alarm action is executed.

[0027] Further, the high-speed eccentricity correcting operation in S8 comprises following steps:

[0028] S81. Perform speed, acceleration correction action, the sensor module detecting the high-speed eccentricity in real time;

[0029] S82. Determining whether or not the high-speed eccentricity exceeds the limit value;

[0030] S83. If the determination result is YES, performing a deceleration eccentricity correcting operation and proceeding next step; if the determination result is NO, end with the high-speed dehydration action.

[0031] S84. End with a relative low-speed dehydration action.

[0032] Further, the sensor module comprises six-axis sensors, the six-axis sensors comprise a three-axis accelerom-

eter and a three-axis gyroscope, the three-axis accelerometer detects a linear acceleration and an inclination angle of an outer tub and it can detect amplitude and direction of linear and gravitational acceleration combined, the three-axis gyroscope detects the rotational angular velocity of the outer tub and tracks a moving direction of the outer tub and the rotational movement.

[0033] Further, the sensor module further comprises an arithmetic control chip, the arithmetic control chip:

[0034] in the eccentricity detection action in the test dehydration process and the low-speed dehydration action stages, corrects the eccentricity limit value and analyze an algorithm to calculate dehydration curve of not thumping a casing according to data detected by the three-axis accelerometer and the three-axis gyroscope and a distance between the outer tub and the casing.

[0035] During the high-speed dehydration action stage or relative low-speed dehydration action stage, running the algorithm and correct the velocity and acceleration dehydration curve based on the algorithm, and doing a real-time correction based on data from three-axis accelerometer and three-axis gyroscope. Maintaining a not thumping the casing state until the dehydration process is complete.

[0036] Further, the sensor module is installed on a bottom of the outer tub or on a side of the outer tub or on a boom.

[0037] Further, a real-time detection position of the sensor module is set at least at one clock point on an upper part of the outer tub and/or in a middle of the outer tub and/or on a lower part of the outer tub, preferably, the real-time detection position of the sensor module is respectively set at 8 clock points of three levels of the upper part, the middle part and the lower part of the outer tub.

[0038] A washing machine using the method above is provided in the present disclosure, comprising an eccentricity detecting device, the eccentricity detecting device comprises a control module, a motor driving module and a sensor module, the motor drive module and the sensor module are respectively connected with the control module, the motor driving module and the sensor module are communicated in real time through the control module.

[0039] A washing machine using the method above is provided in the present disclosure, comprising a main control module and function control modules, each function control module is respectively connected with a corresponding load, the function control modules comprises the sensor module, the sensor module and the main control module are mutually independent; the main control module and the sensor module are respectively connected with a data bus and a power bus, wherein a load of the sensor module corresponding to the sensor module is an acceleration sensor for unbalance detection of the washing machine, or a six-axis sensor or a nine-axis sensor.

[0040] Further, the load of the sensor module is set on the bottom of the outer tub or on the side wall of the outer tub or at the boom; the sensor module is arranged on the load of the sensor module or near the load of the sensor module.

[0041] Further, the function control modules at least comprise a motor control module, a water inlet control module and a drainage control module, wherein at least one of the function control modules is provided independently from the main control module, the main control module, each independent setting function control module is respectively connected with the data bus and the power bus, preferably,

all of the function control modules are independently set with the main control module.

[0042] Further, the function control modules also include a door lock control module, a drying control module, an automatic delivery control module, or a heating control module, or a combination of at least two of them.

[0043] The method for detecting imbalance of washing machine of the present disclosure using a six-axis sensor to achieve the active real-time eccentricity detection of washing machine, therefore, the detection result is more accurate and timely, meanwhile, the real-time detection of the sensor helps the control module of the washing machine to correct the eccentricity according to the detection result in time. The detecting method of the present disclosure is more accurate, improves the efficiency of dehydration, avoids the phenomenon of thumping the casing of the washing machine, and prolongs the service life of the washing machine.

[0044] In particular, the present disclosure has the following technical effects:

[0045] 1) After entering the dehydration timing sequence, first preform the eccentricity detection test dehydration action. During the action, the sensor module detects eccentricity in real-time and the control module of the washing machine sets the preliminary dehydration curve in accordance with the eccentricity detection result. Therefore, the preliminary dehydration curve takes preliminary eccentricity state of washing machine into consideration in the present disclosure which is more in line with the actual situation and greatly reducing the probability of eccentric formal dehydration.

[0046] 2) The present disclosure divides the dehydration process into a low-speed dehydration stage and a high-speed dehydration stage. Eccentricity detection is carried out in both the low-speed dehydration stage and the high-speed dehydration stage and the washing machine won't enter the high-speed dehydration stage when the eccentricity in the low-speed stage doesn't be corrected. Therefore, the method for eccentricity detection of the present disclosure is more accurate, more timely and can avoid washing machine damage from eccentric spinning.

[0047] 3) The present disclosure mainly carries out two eccentricity correction modes in the low speed dehydration stage. One is to stop the low-speed dewatering, then to modify the dehydration curve through the sensor module, to start the low speed dehydration stage again and carry out the eccentric correction. The other one is when the first eccentricity correction method is invalid after a number of corrections, the use of the correction operation of inflooding water for washing, then drain water and re-enter the water dehydration process. Therefore, the eccentricity correction of the present disclosure utilizes different eccentricity correction modes depending on different stages and the different eccentricity results, making the eccentricity correction of the present disclosure more effective

[0048] 4) The eccentricity correction of the present disclosure mainly concentrates on the low-speed dehydration stage, and directly enters the high-speed dehydration stage when the low-speed dehydration stage has no eccentricity. And when the eccentricity on the low-speed dehydration stage is not corrected, the washing machine will not enter the high-speed dehydration stage. It makes the high-speed dehydration stage go smoothly and safely.

[0049] 5) The eccentricity detection is also carried out during the high-speed dehydration stage in the present

disclosure. When eccentricity is too large, a high-speed dehydration correction will be carried out. Since the eccentricity of the low-speed dehydration stage is within the limit value, the high-speed eccentricity correction in the high-speed dehydration stage is relatively simple, mainly by modifying the operation of acceleration and velocity. When the correction method can't achieve the expected effect of correction, the dehydration speed will be reduced to complete the dehydration process. Therefore, the high-speed dehydration stage of the present disclosure can proceed safely and accurately, it effectively avoids a probability of too large eccentricity during the high-speed dehydration phase, ensures the smooth process of dehydration.

[0050] 6) A six-axis sensor is provided in the present disclosure to detect the eccentricity of the washing machine and realizes the active real-time detection of the eccentricity of the washing machine. A three-axis accelerometer of the six-axis sensor senses the linear acceleration and the inclination angle, the three-axis gyroscope senses the rotational angle. Therefore, the six-axis sensor provided in the present disclosure not only can detect the linear acceleration and the inclination angle of the outer tub in real-time, but also can avoid the rotation angle brought about by the rotation of the inner tub to the greatest extent, so that the detection result of the disclosure is more accurate.

[0051] 7) The real-time detection position of the sensor module of the present disclosure is respectively set at 8 clock points of three levels of the upper part, the middle part and the lower part of the outer tub. Therefore, the detection result is more accurate and the respond is more rapid.

BRIEF DESCRIPTION OF THE DRAWINGS

[0052] FIG. 1 is a process control flow chart of the present disclosure;

[0053] FIG. 2 a dehydration curve of the present disclosure;

[0054] FIG. 3 is a schematic diagram of the sensor module of the present disclosure;

[0055] FIG. 4 is a control schematic diagram of the detecting device of the present disclosure;

[0056] FIG. 5 is a composition schematic diagram of the MEMS sensor of the present disclosure;

[0057] FIG. 6 is a schematic diagram of the eccentricity detection position of the present disclosure;

[0058] FIG. 7 is a schematic diagram of an inclination angel of the washing machine of the present disclosure;

[0059] FIG. 8 is structural schematic of the washing machine of the present disclosure;

[0060] FIG. 9 is schematic diagram of the power bus connection of the washing machine of the present disclosure;

[0061] FIG. 10 is a schematic diagram of the data bus connection of the washing machine of the present disclosure.

[0062] Description of major components: 1—main control module, 2—power bus, 3—data bus, 4—water inlet control module, 5—drainage control module, 6—door lock control module, 7—drying control module, 8—automatic delivery control module, 9—heating control module, 10—motor control module, 11—control panel, 12—power adapter, 13—sensor module, 41—water inlet valve, 51—drain valve, 61—door lock, 71—drying assembly, 81—automatic delivery module, 91—heating wire, 101—load motor, 131—sensor module load.

DETAILED DESCRIPTION OF THE INVENTION

[0063] Specific embodiments about a method for detecting imbalance of washing machine of the present disclosure are further described below in detail with reference to the accompanying drawings.

[0064] As shown in FIG. 1, a process control flow chart of a method for detecting imbalance of washing machine of the present disclosure which comprises following steps:

[0065] S1. Running a dehydration process and performing an eccentricity detection action in a test run of the dehydration process.

[0066] When a washing machine enters the dehydration process, first the eccentricity detection action in the test run of the dehydration process is performed. The purpose of the eccentricity detection action in the test dehydration process is to detect the eccentricity state of the washing machine at the beginning of the dehydration process. The eccentricity detection action in the test run of the dehydration process is that the sensor detection module immediately detects the eccentricity of the washing machine to get the initial eccentricity at the moment of rotation which is a slight rotation of the washing machine inner tub. Since the eccentricity detecting method of the present disclosure includes the eccentricity detection action in the test run of the dehydration process, the present disclosure can avoid “jumps and bangs” phenomenon due to a large eccentricity when the washing machine initially enters the dehydration stage. And this phenomenon in the dehydration stage of the existing washing machine is unavoidable and the frequency of occurrence is very high.

[0067] S2. A sensor module performs an eccentricity detection operation to detect an eccentricity state of the washing machine in real-time and sets a preliminary dehydration curve.

[0068] The washing machine of the present disclosure is provided with a sensor module for detecting the eccentricity, and the sensor module of the present disclosure can detect actively the eccentricity of the washing machine in real-time. The sensor module works at the eccentricity detection action in the test run of the dehydration process and sets a preliminary dehydration curve based on an initial eccentricity of the outer tub detected by the sensor module. The preliminary dehydration curve set in the present disclosure is the theoretical curve of the dehydration stage, which generally includes eccentricity detection test dehydration stage, low-speed dehydration stage and high-speed dehydration stage. However, in the actual dehydration process, the eccentricity will be amended, therefore, the initial setting of the dehydration curve will make the appropriate amendments to ensure the dehydration stage to go smoothly. The preliminary dehydration curve set by the disclosure can be selected according to the initial eccentricity of the washing machine to obtain the most suitable dehydration speed to ensure the smooth dehydration and avoid the eccentric bucket “jumps and bangs” phenomenon.

[0069] S3. Performing a low-speed dehydration action, the sensor module detects a low-speed eccentricity in real time.

[0070] The present disclosure performs the low-speed dehydration action in a low-speed dehydration stage, the sensor module detects eccentricity in real time on low-speed dehydration stage. The washing machine first enters the low-speed dehydration stage based on the preliminary dehydration curve. When the eccentricity is corrected on the

low-speed dehydration stage, the preliminary dehydration curve is corrected accordingly, and the washing machine re-enters the low-speed dehydration stage based on the corrected dehydration curve.

[0071] S4. Determining whether or not the detected low-speed eccentricity exceeds a limit value.

[0072] The limit value of the present disclosure need to be set by corresponding experiment, and limit value of different type of washing machines are different from each other due to different washing machine models. The limit value is the critical inclination angle of the outer tub hitting the casing of washing machine when the outer tub is eccentric during the dehydration stage of the washing machine.

[0073] S5. If the determination result is YES, a low-speed eccentricity correcting operation is executed, and if the determination result is NO, proceed to the next step.

[0074] S6. Performing a high-speed dehydration action, the sensor module detects a high-speed eccentricity in real time.

[0075] S7. Determining whether or not the detected high-speed eccentricity exceeds a limit value.

[0076] S8. If the determination result is YES, a high-speed eccentricity correcting operation is executed, and if the determination result is NO, end with high-speed dehydration action.

[0077] The imbalance detection method of the present disclosure divides the dehydration process into three stages: the eccentricity detection test dehydration stage, on which preliminary dehydration curve is set based on the initial eccentricity detected through test dehydration; the low-speed dehydration stage, which is the main stage for eccentricity detection and correction, and if the eccentricity of the low-speed dehydration stage is not corrected, the washing machine doesn't enter the high-speed dehydration stage; high-speed dehydration stage which is the main stage for dehydration, and eccentricity detection and correction are also executed. It should be understood by a person skilled in the field that since the eccentricity has met the requirement in the low-speed dehydration stage the dehydration process ends with the high-speed dehydration stage.

[0078] Therefore, the imbalance detection method of the present disclosure can actively detect and correct the eccentricity of the washing machine in real time, and targeted eccentricity detection and correction are carried out during different dehydration stages. The imbalance detection method of the present disclosure is more accurate and the reaction is more sensitive.

[0079] As a preferred embodiment of the present disclosure, an eccentricity correction method performed on a low speed dehydration stage is simultaneously disclosed in the present disclosure. Specifically, the low speed eccentricity correcting operation in S5 includes the following steps:

[0080] S51. Stopping the low-speed dehydration;

[0081] S52. Correcting the dehydration curve;

[0082] S53. Performing the low-speed dehydration action in accordance with the corrected dehydration curve and backing to S3.

[0083] When the eccentricity detected by the sensor module of the present disclosure exceeds the limit value, that is the outer tub has the tendency to hit the casing or a state to hit the casing, a control module will stop motor and the sensor module will re-correct the dehydration curve. The washing machine will re-enter the low-speed dehydration stage based on the corrected dehydration curve.

[0084] As a preferred embodiment of the present disclosure, the low-speed eccentricity correcting operation is executed up to N times in S5, wherein, the N satisfies: $0 < N \leq 10$; preferably, $N=3$.

[0085] As a preferred embodiment of the present disclosure, S51-S53 above can't solve the problem that the eccentricity exceeds the limit value, which is, when the low-speed eccentricity correcting operation is executed more than N times in S5, following steps are executed:

[0086] S54. Performing a correction operation of inflooding water for washing is executed;

[0087] S55. Performing a drain operation;

[0088] S56. Backing to S1. As a preferred embodiment of the present disclosure, S54 of the present disclosure is executed up to M times, wherein, the M satisfies: $0 < M \leq 10$, preferably, $M=3$. If S54 is executed more than M times, an alarm action is executed.

[0089] The eccentric correction method is that the control module orders the water inlet valve to supply water and re-wash to balance eccentricity. The washing machine re-runs the dehydration process after balanced the eccentricity and drained. If the inlet water correction is repeated three times and still can't avoid "jumps and bangs" phenomenon, then the control module alarms.

[0090] Analysis of the above two kinds of eccentricity correction in the low-speed dehydration stage shows that the washing machine of the present disclosure enters the high-speed dehydration stage only when the eccentricity in the low-speed dehydration stage is smaller than the limit value. When the eccentricity can't be corrected, the control module alarms, and the users need to manually balance the eccentricity or seek related repairs according to the alarm. Therefore, the method of the present disclosure can avoid "jumps and bangs" phenomenon due to a too large eccentricity in the high-speed dehydration stage, and the damage to the casing of the washing machine which caused by the "jumps and bangs" phenomenon in the high-speed dehydration stage is often great.

[0091] In order to further ensure the smooth progress of the dehydration stage, the present disclosure simultaneously performs eccentricity detection and eccentricity correction in the high-speed dehydration stage. As a preferred embodiment of the present disclosure, the high-speed eccentricity correcting operation in S8 comprises following steps:

[0092] S81. Performing a speed, acceleration correction action, the sensor module detecting the high-speed eccentricity in real time;

[0093] S82. Determining whether or not the high-speed eccentricity exceeds the limit value;

[0094] S83. If the determination result is YES, performing a deceleration eccentricity correcting operation and proceeding next step; if the determination result is NO, ending with the high-speed dehydration action.

[0095] S84. Ending with the low-speed dehydration action.

[0096] The correction result of the high-speed dehydration stage of the present invention ends with the high-speed dehydration action or a relative low-speed dehydration operation, it is mainly because the washing machine enters the high-speed dehydration stage only when the eccentricity in the low-speed stage of the present disclosure is smaller than the limit value. Therefore, strictly speaking, the high-speed eccentricity correcting operation of the present disclosure is intended to further ensure the smooth completion

of the dehydration. The relative low-speed dehydration operation mentioned in the present disclosure means that the dehydration speed is slightly smaller than the set rotational speed of the originally high-speed dehydration stage, but the lower rotational speed still satisfies the dehydration requirement and does not cause a “jumps and bangs” phenomenon. Therefore, the eccentricity correction in the high-speed dehydration stage of the present disclosure is achieved mainly by the control module commanding the motor to drive module to correct the acceleration and the speed.

[0097] As shown in FIG. 2 is a dehydration curve of the present disclosure, which in the figure:

[0098] Stage 0-a: eccentricity detection action in the test run of the dehydration process;

[0099] Stage a-b: motor stopping;

[0100] Stage b-c: motor accelerating and entering low-speed dehydration stage;

[0101] Stage c-d: low-speed dehydration stage, the motor running at low speed;

[0102] Stage d-e: motor accelerates and entering high-speed dehydration stage;

[0103] Stage e-f: high-speed dehydration stage, the motor running at high speed.

[0104] It should be understood by a person skilled in the field that the dehydration curve is just an example curve. During the actual operation, the dehydration curve is different due to the different actual dehydration situation. For example, the motor in stage a-b does not stop, the motor decelerates to a certain value or enters the low-speed dehydration stage directly from the test dehydration stage. It gradually enters into the high-speed dehydration stage of e-f from the low-speed dehydration stage of c-d by multiple adjustments. Rather than in this curve directly from the low-speed dehydration stage of a one-time accelerated into the high-speed dehydration stage.

[0105] As shown in FIG. 3, the sensor module of the present disclosure is divided into two parts: a MEMS sensor and an arithmetic control chip.

[0106] As a preferred embodiment of the present disclosure, MEMS sensor comprises six-axis sensor. The six-axis sensor comprises a three-axis accelerometer and a three-axis gyroscope. The three-axis accelerometer detects a linear acceleration and an inclination angle of an outer tub and it can detect amplitude and direction of linear and gravitational acceleration combined, the three-axis gyroscope detects the rotational angular velocity of the outer tub and tracks a moving direction of the outer tub and the rotational movement.

[0107] As another preferred embodiment of the present disclosure, MEMS sensor comprises nine-axis sensors. The nine-axis sensors comprise a three-axis accelerometer, a three-axis gyroscope and a three-axis magnetometer. As shown in FIG. 5, the three-axis accelerometer detects a linear acceleration and an inclination angle of an outer tub and it can detect amplitude and direction of linear and gravitational acceleration combined, the three-axis gyroscope detects the rotational angular velocity of the outer tub and tracks a moving direction of the outer tub and the rotational movement, the three-axis magnetometer detects a direction of the outer tub.

[0108] The arithmetic control chip of the present disclosure:

[0109] In the eccentricity detection action in test dehydration process and the low-speed dehydration action stages,

correct the eccentricity limit value and analyze an algorithm to calculate dehydration curve of not thumping a casing according to data detected by the three-axis accelerometer and the three-axis gyroscope and a distance between the outer tub and the casing.

[0110] During the high-speed dehydration action stage or a relative low-speed dehydration action stage, running in accordance with the dehydration curve corrected by the velocity and acceleration based on the algorithm, and doing a real-time correction based on data from three-axis accelerometer and three-axis gyroscope. Maintaining a not thumping the casing state until the dehydration process is complete.

[0111] As a preferred embodiment of the present disclosure, the sensor module is installed on a bottom of the outer tub or on a side of the outer tub or on a boom. The working principle of the sensor module of the present disclosure is different from the working principle of the existing detection method, the mounting method of the sensor module of the present disclosure is more simple and flexible.

[0112] In order to further increase the detection accuracy, as shown in FIG. 6, a real-time detection position of the sensor module of the present disclosure is set at least at one clock point on an upper part of the outer tub, and/or in a middle of the outer tub, and/or on a lower part of the outer tub, preferably, the real-time detection position of the sensor module is respectively set at 8 clock points of three levels of the upper part, the middle part and the lower part of the outer tub.

[0113] In the actual use of the process, a washing machine body may be tilt due to uneven position where the washing machine placed. It is necessary to take this variable into account with the actual eccentricity limit value. As shown in FIG. 7, the eccentricity limit value of the present disclosure also dependent on an inclination angle α of the washing machine body to a horizontal plane, wherein $0 < \alpha \leq 10^\circ$. The limit value is valid only when the inclination angle α of the washing machine body is within this range, and when the inclination angle is excessively large, the limit value is no longer applicable.

[0114] As shown in FIG. 4, a washing machine using the imbalance detection method is provided in the present disclosure, and comprises an eccentricity detecting device, the eccentricity detecting device comprises a control module, a motor driving module and a sensor module, the motor drive module and the sensor module are respectively connected with the control module, the motor drive module and the sensor module are communicated through the control module in real time.

[0115] The control module is responsible for controlling the motor drive module and the sensor module; the motor drive module is responsible for real-time motor speed feedback; the sensor module is responsible for eccentricity detection and correction of the dehydration acceleration and speed.

Embodiment 1

[0116] As shown in FIG. 8, a washing machine using the imbalance detection method in the present disclosure, comprises a main control module 1 and function control modules. Each function control module is respectively connected with a corresponding load. The function control modules comprise the sensor module 13, and the sensor module 13 and the main control module 1 are mutually independent.

The main control module **1** and the sensor module **13** are respectively connected with a data bus **3** and a power bus **2**. The sensor module load (**131**) corresponding to the sensor module **11** is an acceleration sensor, a six-axis sensor or a nine-axis sensor for unbalance detection of the washing machine.

[0117] As a preferred embodiment of the present disclosure, the function control module at least comprises a motor control module **10**, a water inlet control module **4** and a drainage control module **5**, wherein at least one of the function control modules is provided independently from the main control module **1**. The main control module **1** and each independent setting function control module are respectively connected with the data bus **3** and the power bus **2**. Preferably, all of the function control modules are independently set with the main control module **1**.

[0118] In this embodiment, each function control module is respectively connected with a corresponding load, and is arranged on the load of the sensor module or near the load of the sensor module. The load of the main control module **1** is a control panel **11**, and the circuit board provided with the main control module **1** is installed at the control panel **11**. The control panel **11** further comprises human-computer interaction devices such as keys, a digital tube and an LCD display screen. And the load of the main control module **1** is function control modules. The human-computer exchange information of the control panel **11** and the information fed back by function control modules are processed and analyzed, and then the instruction signals are sent to the function control modules. So that each function control module in accordance with the corresponding instruction signal controls the corresponding loads.

[0119] In this embodiment, the load of the motor control module **10** is a load motor **101**, and the load motor **101** is a series motor, a variable frequency motor or a DD direct-drive motor or any other motors. The motor control module **10** is provided on a separate circuit board or on a control circuit board. Preferably, the separate circuit board with motor control module **10** is mounted on or near the load motor **101**. Further preferably, the motor control module **10** is a smart computer board mounted on the load motor **10**.

[0120] In this embodiment, the load of the water inlet control module **4** is an inlet assembly for controlling the on-off state of the water inlet pipe. In this embodiment, the inlet assembly is provided as a water inlet valve **41**, and the inlet control module **4** is provided on a separate circuit board or on a control circuit board. Preferably, the separate circuit board with the water inlet control module **4** is installed near the water inlet valve **41**. Further preferably, the inlet control module **4** is a smart computer board installed near the water inlet valve **41**.

[0121] In this embodiment, the load of the drainage control module **5** is a load drainage module, and the load drainage module is a drain pump and/or a drain valve **51** for controlling the opening and closing of the drain pipe. In this embodiment, the load drainage module is the drain valve **51**. The drainage control module **5** is provided on a separate circuit board or on the control circuit board. Preferably, the separate circuit board provided with the drainage control module **5** is installed near the drain valve **51**. Further preferably, the drainage control module **5** is a smart computer board installed near the drain valve **51**.

[0122] In this embodiment, the above-mentioned separate circuit board is a separately provided and separated from the

control circuit board. Thus, the corresponding function control module of each load is realized to be set independently, which simplifies the steps of circuit board maintenance and replacement, improves the maintenance and production efficiency of the washing machine.

[0123] In this embodiment, the motor control module **10**, the water inlet control module **4** and the drainage control module **5** are respectively provided with a data bus terminal and a power bus terminal. The data bus terminal of each function control module is respectively connected with the data bus **3**, and the power bus terminal is respectively connected with the power bus **2**.

[0124] The power bus terminal of each function control module is connected with the power bus and the function control module controls the on-off of the power bus and the load of each road, so that the corresponding load takes power and operates. At the same time, by connecting the data bus terminals of the function control modules to the data bus, the human-computer interaction information obtained by the main control module is transmitted to the function control module to control the operation state of the corresponding load, or the action information of each load is fed back to the main control module to realize the communication transmission between the main control module and the function control modules.

[0125] As shown in FIG. 9, in this embodiment, at the power adapter **12** of the washing machine the power bus **2** extends towards the inside of the washing machine casing. The power bus **2** sequentially passes through the control panel **11**, the sensor module load **131**, the water inlet valve **41**, the load motor **101**, and the drain valve **51**. The power bus **2** is provided with a corresponding port on the control panel **11**, the sensor module load **131**, the water inlet valve **41**, the load motor **101** and the drain valve **51**, and the ports are respectively connected with the corresponding terminals of the main control module **1**, the sensor module **13**, the water inlet control module **4**, the motor control module **10** and the drainage control module **5**. The main control module **1**, the sensor module **13**, the water inlet control module **4**, the motor control module **10** and the drainage control module **5** are connected in series by the power bus to realize the power distribution of each function control module arranged on the load or near the load. In this embodiment, the main control module and each function control module can also be connected in series in any order via the power bus.

[0126] As shown in FIG. 10, in this embodiment, the data bus **3** extends from the control panel at the upper portion of the washing machine toward the inside of the washing machine casing. The data bus **3** sequentially passes through the sensor module load **131**, the water inlet valve **41**, the load motor **101**, and the drain valve **51**. The data bus **3** is provided with corresponding ports at the sensor module load **131**, the water inlet valve **41**, the load motor **101**, and the drain valve **51**, and the ports are respectively connected with the corresponding terminals of the sensor module **13**, the water inlet control module **4**, the motor control module **10** and the drainage control module **5**. The main control module **1**, the sensor module **13**, the water inlet control module **4**, the motor control module **10** and the drainage control module **5** are connected in series by the data bus to realize the information transmission between the function control modules arranged on the loads or near the loads. In this embodi-

ment, the main control module and each function control module can also be connected in series in any order via the power bus.

[0127] As a preferred embodiment of the present disclosure, the function control module also includes one of the followings: a door lock control module 6, a drying control module 7, an automatic delivery control module 8, or a heating control module 9, or a combination of at least two of them.

[0128] As a preferred embodiment of the present disclosure, the load of the drying control module 7 is drying assembly 71 constituting the laundry drying system of the washing machine. The drying control module 7 may be provided on a separate circuit board or on a control circuit board. Preferably, the drying control module 7 is a smart control computer board for controlling the operation state of the drying assembly 71 of the washing machine and installed near the drying assembly. The smart control computer board forming the drying control module 7 is directly connected to the drying assembly.

[0129] In this embodiment, the data bus 3 sequentially passes through the control panel 11, the drying assembly 71, the water inlet valve 41, the load motor 101, and the drain valve 51. The data bus 3 is provided with corresponding ports at the loads, and the ports are respectively connected with the corresponding terminals of the drying control module 7, the water inlet control module 4, the motor control module 10 and the drainage control module 5. The data bus connects the main control module, the drying control module, the water inlet control module, the motor control module and the drainage control module in series to realize the information transmission between the functional control modules arranged on the loads or near the loads. In this embodiment, the main control module and the function control modules can also be connected in series in any order via a data bus.

[0130] In this embodiment, at the power adapter 12 of the washing machine, the power bus 2 extends towards the inside of the washing machine casing. The power bus 2 sequentially passes through the control panel 11, the drying assembly 71, the water inlet valve 41, the load motor 101, and the drain valve 51. The power bus 2 is provided with corresponding ports at the loads, and the ports are respectively connected with the corresponding terminals of the main control module 1, drying control module 7, water inlet control module 4, motor control module 10 and drainage control module 5. The main control module, the drying control module, the water inlet control module, the motor control module and the drainage control module are connected in series in series through the power bus to realize the power distribution of function control modules set on the loads or near the loads. In this embodiment, the main control module and the function control modules can also be connected in series in any order via the power bus.

[0131] As a preferred embodiment of the present disclosure, the automatic delivery control module 8 may be provided on the separate circuit board or on the control circuit board. The load of the automatic delivery control module 8 is an automatic delivery module 81 for controlling the delivery of the detergent box 82. In this embodiment, the automatic delivery module 81 is composed of an automatic dispenser which is communicated with the outer tub of the washing machine via a delivery line, and the delivery line is provided with a control valve. Preferably, the automatic

delivery control module 8 is a smart control computer board installed near the control valve for controlling the amount of the liquid detergent and/or the powder detergent and/or softening agent in the washing machine. The smart control computer board constituting the automatic delivery control module 8 is directly connected to the control valve constituting the automatic delivery module 81.

[0132] In this embodiment, the data bus 3 is sequentially passed through the control panel 11, the automatic delivery module 81 of the detergent box, the water inlet valve 41, the load motor 101, and the drain valve 51. The data bus 3 is provided with corresponding ports at the loads, and the ports are respectively connected with the corresponding terminals of the automatic delivery control module 8, the water inlet control module 4, the motor control module 10, and the drainage control module 5. The data bus connects the main control module, the automatic delivery control module, the water inlet control module, the motor control module and the drainage control module in series in order to realize the information transmission between the functional control modules arranged on the loads or near the loads. In this embodiment, the main control module and the function control modules can also be connected in series in any order via a data bus.

[0133] In this embodiment, at the power adapter of the washing machine the power bus 2 extends towards the inside of the washing machine casing. The power bus 2 sequentially passes through the control panel 11, the automatic delivery module 81 of the detergent box 82, the water inlet valve 41, the load motor 101, and the drain valve 51. The power bus 2 is provided with corresponding ports at the loads, and the ports are respectively connected with the corresponding terminals of the main control module 1, the automatic delivery control module, the water inlet control module 4, the motor control module 10 and the drainage control module 5. The main control module, the automatic delivery control module, the water inlet control module, the motor control module and the drainage control module are sequentially connected in series through the power bus to realize the power distribution of the function control modules arranged on the loads or near the loads. In this embodiment, the main control module and the function control modules can also be connected in series in any order via the power bus.

[0134] As a preferred embodiment of the present disclosure, the heating control module 9 may be provided on a separate circuit board or on a control circuit board. The load of the heating control module is heating assembly in the heating system. The heating assembly includes a heating wire 91, a heating tube or a heat pump system, etc. In this embodiment, preferably, the heating assembly is the heating wire 91. Further preferably, the heating wire 91 is arranged in the water inlet pipe to heat the inlet water flow. The heating control module 9 is a smart control computer board installed near the heating wire 91 for controlling the heating state of the heating assembly of the washing machine. The smart control circuit constituting the heating control module 9 is directly connected to the heating wire 91.

[0135] In this embodiment, the data bus 3 passes through the control panel 11, the water inlet valve 41, a position near the heating wire 91, the load motor 101, and the drain valve 51. The data bus 3 is provided with corresponding ports at the loads, and the ports are respectively connected with the corresponding terminals of the water inlet control module 4,

the heating control module 9, the motor control module 10 and the drainage control module 5. The data bus connects the main control module, the water inlet control module, the heating control module, the motor control module and the drainage control module in series, so as to realize the information transmission between the functional control modules set on the load or near the load. In this embodiment, the main control module and the function control modules can also be connected in series in any order via a data bus.

[0136] In this embodiment, at the power adapter of the washing machine the power bus 2 extends towards the inside of the washing machine casing. The power bus 2 sequentially passes through the control panel 11, the water inlet valve 41, a position near the heating wire 91, the load motor 101, and the drain valve 51 in this order. The power bus 2 is provided with corresponding ports at the loads, and the ports are respectively connected with the corresponding terminals of the main control module 1, water inlet control module 4, heating control module 9, motor control module 10 and drainage control module 5. The main control module, the water inlet control module, the heating control module, the motor control module and the drainage control module are sequentially connected in series through the power bus to realize the power distribution of the functional control modules set on or near the load. In this embodiment, the main control module and the function control modules can also be connected in series in any order via the power bus.

[0137] As a preferred embodiment of the present disclosure, in the embodiment, at least one function control module and the main control module 1 are provided on the control circuit board, and the function control modules provided on the control circuit board in common with the control module 1 are respectively connected with the corresponding loads via a connection line. And the control circuit board provided with the main control module and at least one function control module is connected in series via the power bus and the data bus to the functional control modules provided on the circuit board which is relatively independent from the control circuit board. The separate circuit boards provided with the functional control modules are installed on or near the corresponding loads.

[0138] The main control module 1 and the function control modules which are provided on the control circuit board are connected with each other through the connection circuit, and the main control module 1 and the function control modules are respectively connected with the power bus via the terminals of the power bus, connected with the data bus via the terminals of the data bus, so that the main control module 1 provided on the control circuit board and the function control modules are respectively connected with the other function control modules provided on the separate circuit boards in series to achieve the connection between the main control module 1 and the function control modules. It achieves the purpose of data transmission between modules and power control.

[0139] The implementation solutions in the above embodiments can be further combined or replaced, and the embodiments merely describe preferred embodiments of the present disclosure, instead of limiting the concept and the scope of the present disclosure; without departing from the design concept of the present disclosure, various variations and improvements made to the technical solutions of the present disclosure by persons skilled in the art all belong to the protection scope of the present disclosure.

1. A method for detecting imbalance of a washing machine, comprising the following steps:

- S1, Running a dehydration process and performing an eccentricity detection action in a test dehydration process;
- S2, Performing, with a sensor module, an eccentricity detection operation to detect an eccentricity state of the washing machine in real time and setting a preliminary dehydration curve;
- S3, Performing a low-speed dehydration action in accordance with the preliminary dehydration curve, and the sensor module detecting a low-speed eccentricity in real time;
- S4, Determining whether or not the detected low-speed eccentricity exceeds a first limit value;
- S5, If a first determination result is YES, performing a low-speed eccentricity correcting operation, and if the first determination result is NO, proceeding to next step;
- S6, Performing a high-speed dehydration action, and the sensor module detecting a high-speed eccentricity in real time;
- S7, Determining whether or not the high-speed eccentricity exceeds a second limit value;
- S8, If a second determination result is YES, performing a high-speed eccentricity correcting operation, and if the second determination result is NO, ending with the high-speed dehydration action.

2. The method for detecting imbalance of the washing machine according to claim 1, wherein, the low-speed eccentricity correcting operation in step S5 comprises the following steps:

- S51, Stopping the low-speed dehydration action;
- S52, Correcting a dehydration curve;
- S53, Performing the low-speed dehydration action in accordance with a corrected dehydration curve and returning to S3.

3. The method for detecting imbalance of the washing machine according to claim 2, wherein, the low-speed eccentricity correcting operation is executed up to N times in S5, and the N satisfies: $0 < N \leq 10$.

4. The method for detecting imbalance of the washing machine according to claim 3, wherein, when a number of performing the low-speed eccentricity correcting operation is more than N times in step S5, the following steps are performed:

- S54, Performing a correction operation of inflooding water for washing;
- S55, Performing a drain operation;
- S56, Returning to S1.

5. The method for detecting imbalance of the washing machine according to claim 4, wherein, S54 is executed up to M times, and M satisfies: $0 < M \leq 10$, if S54 is executed more than M times, an alarm action is executed.

6. The method for detecting imbalance of the washing machine according to claim 1, wherein, the high-speed eccentricity correcting operation in step S8 comprises following steps:

- S81, Performing speed, acceleration correction action, the sensor module detecting the high-speed eccentricity in real time;
- S82, Determining whether or not the high-speed eccentricity exceeds the second limit value;

- S83.** If the determination result is YES, executing a deceleration eccentricity correcting operation is executed and proceeding to the next step; if the determination result is NO, end with the high-speed dehydration action;
- S84.** Ending with a relative low-speed dehydration action.
- 7.** The method for detecting imbalance of the washing machine according to claim 1, wherein, the sensor module comprises a six-axis sensor,
- the six-axis sensor comprises a three-axis accelerometer and a three-axis gyroscope,
 - the three-axis accelerometer detects a linear acceleration and an inclination angle of an outer tub, and detects amplitude and direction of linear and gravitational acceleration combined,
 - the three-axis gyroscope detects a rotational angular velocity of the outer tub and tracks a moving direction of the outer tub and a rotational movement.
- 8.** The method for detecting imbalance of the washing machine according to claim 7, wherein, the sensor module further comprises an arithmetic control chip:
- in the eccentricity detection action in the test dehydration process and the low-speed dehydration action stages, the arithmetic control chip corrects the first and second limit value of the eccentricity and analyzes an algorithm to calculate the dehydration curve of not thumping a casing according to data detected by the three-axis accelerometer and the three-axis gyroscope and a distance between the outer tub and the casing;
 - during the high-speed dehydration action stage or relative low-speed dehydration action stage, running in accordance with the dehydration curve corrected by the velocity and acceleration based on the algorithm, and doing a real-time correction based on data from three-axis accelerometer and three-axis gyroscope, maintaining a not thumping the casing state until the dehydration process is complete.
- 9.** The method for detecting imbalance of the washing machine according to claim 1, wherein, the sensor module is installed on a bottom of the outer tub or on a side of the outer tub or on a boom.
- 10.** The method for detecting imbalance of the washing machine according to claim 1, wherein, a real-time detection position of the sensor module is set at least at one clock point on an upper part of the outer tub, in a middle of the outer tub, and/or on a lower part of the outer tub.
- 11.** A washing machine using the method according to claim 1, wherein, the washing machine comprises an eccentricity detecting device,
- the eccentricity detecting device comprises a control module, a motor driving module and a sensor module,
 - the motor drive module and the sensor module are respectively connected with the control module, or the motor driving module and the sensor module are communicated through the control module in real time.
- 12.** A washing machine using the method according to claim 1, comprising a main control module and function control modules respectively connected with corresponding loads,
- wherein, the function control modules comprise a sensor module,
 - the sensor module and the main control module are mutually independent;
 - the main control module and the sensor module are respectively connected with a data bus and a power bus,
 - a sensor module load corresponding to the sensor module is an acceleration sensor, a six-axis sensor, or a nine-axis sensor for unbalance detection of the washing machine.
- 13.** The washing machine using the method according to claim 12, wherein, the sensor module load is set on a bottom of an outer tub or on a side wall of the outer tub or at a boom; the sensor module is arranged on the sensor module load or near the sensor module load.
- 14.** The washing machine using the method according to claim 12, wherein,
- the function control modules at least comprise a motor control module, a water inlet control module and a drainage control module,
 - at least one of the function control modules is provided independently from the main control module,
 - the main control module and each independent setting function control module are respectively connected with the data bus and the power bus.
- 15.** The washing machine using the method according to claim 12, wherein,
- the function control modules also include: a door lock control module, a drying control module, an automatic delivery control module, or a heating control module, or a combination of at least two of them.
- 16.** The method for detecting imbalance of the washing machine according to claim 1, wherein, the real-time detection position of the sensor module is respectively set at 8 clock points of three levels of the upper part, the middle part and the lower part of the outer tub.
- 17.** The washing machine using the method according to claim 14, wherein,
- all of the function control modules are independently set with the main control module.
- 18.** The washing machine using the method according to claim 13, wherein,
- the function control modules also include: a door lock control module, a drying control module, an automatic delivery control module, or a heating control module, or a combination of at least two of them.
- 19.** The washing machine using the method according to claim 14, wherein,
- the function control modules also include: a door lock control module, a drying control module, an automatic delivery control module, or a heating control module, or a combination of at least two of them.