



(72) KANGASLAHTI, PEKKA, FI
(72) KALAJO, SAMI, FI
(71) YLINEN ELECTRONICS OY, FI

(51) Int.Cl.⁷ H04B 1/62

(30) 1997/08/27 (973525) FI

(54) **CIRCUIT DE LINÉARISATION DE PRÉDISTORSION**

(54) **PREDISTORTION LINEARIZER CIRCUIT**

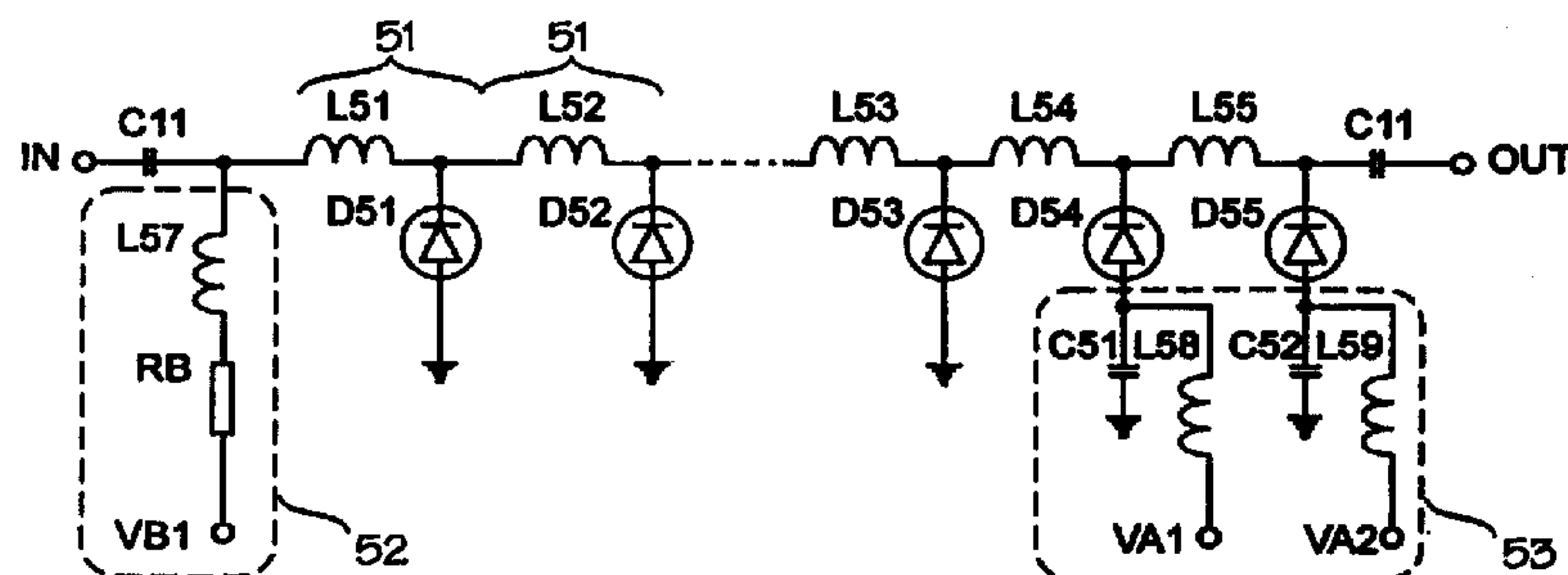

(57) Ce circuit de linéarisation de prédistorsion comporte un élément de distorsion d'amplitude (AM/AM) et un élément de distorsion de phase (AM/PM). L'élément de distorsion de phase (AM/PM), celui-ci au moins, comporte des systèmes de polarisation de bande large (51) et une ligne de transmission non linéaire (L51/D51 - L55/D55) réagissant à ceux-ci. Ces systèmes de polarisation (51) sont conçus pour polariser la ligne de transmission non linéaire (L51/D51 - L55/D55) vers une zone sensiblement de distorsion de phase. Il est possible de modifier les caractéristiques du circuit par adaptation d'une tension de polarisation (VB1) ou par commutation de certaines diodes (D54, D55), les désactivant au moyen de signaux d'activation (VA1, VA2). L'élément de distorsion d'amplitude (AM/AM) et l'élément de distorsion de phase (AM/PM) peuvent avoir une structure similaire mais les diodes (D51 - D55) sont en partie polarisées en sens direct, les pertes qu'elles occasionnent réduisant l'amplitude du signal.

(57) A predistortion linearizer circuit comprising an amplitude distorting part (AM/AM) and a phase distorting part (AM/PM). At least the phase distorting part (AM/PM) comprises broadband biasing means (51) and a non-linear transmission line (L51/D51 to L55/D55) responsive to them. The biasing means (51) are arranged to bias the non-linear transmission line (L51/D51 to L55/D55) to a substantially phase distorting area. The characteristics of the circuit can be changed by adjusting a biasing voltage (VB1) or by switching some of the diodes (D54, D55) inactive by activation signals (VA1, VA2). The amplitude distorting part (AM/AM) and the phase distorting part (AM/PM) can be similar in structure, but the diodes (D51 to D55) are partly forward-biased, whereby the losses caused by them decrease the amplitude of the signal.

PCT

WORLD INTELLECTUAL PROPERTY ORGANIZATION
International Bureau

INTERNATIONAL APPLICATION PUBLISHED UNDER THE PATENT COOPERATION TREATY (PCT)

<p>(51) International Patent Classification ⁶ : H04B 1/62</p>	A2	<p>(11) International Publication Number: WO 99/10987 (43) International Publication Date: 4 March 1999 (04.03.99)</p>
<p>(21) International Application Number: PCT/FI98/00649 (22) International Filing Date: 24 August 1998 (24.08.98) (30) Priority Data: 973525 27 August 1997 (27.08.97) FI (71) Applicant (for all designated States except US): IN-SINÖÖRITOIMISTO JUHANA YLINEN OY [FI/FI]; Teollisuustie 9 A, FIN-02700 Kauniainen (FI). (72) Inventors; and (75) Inventors/Applicants (for US only): KANGASLAHTI, Pekka [FI/FI]; Kalkkikuja 6 B, FIN-02730 Espoo (FI). KALAJO, Sami [FI/FI]; Munkkiniemen puistotie 14 B 34, FIN-00330 Helsinki (FI). (74) Agent: KOLSTER OY AB; Iso Roobertinkatu 23, P.O. Box 148, FIN-00121 Helsinki (FI).</p>	<p>(81) Designated States: AL, AM, AT, AT (Utility model), AU, AZ, BA, BB, BG, BR, BY, CA, CH, CN, CU, CZ, CZ (Utility model), DE, DE (Utility model), DK, DK (Utility model), EE, EE (Utility model), ES, FI, FI (Utility model), GB, GE, GH, GM, HR, HU, ID, IL, IS, JP, KE, KG, KP, KR, KZ, LC, LK, LR, LS, LT, LU, LV, MD, MG, MK, MN, MW, MX, NO, NZ, PL, PT, RO, RU, SD, SE, SG, SI, SK, SK (Utility model), SL, TJ, TM, TR, TT, UA, UG, US, UZ, VN, YU, ZW, ARIPO patent (GH, GM, KE, LS, MW, SD, SZ, UG, ZW), Eurasian patent (AM, AZ, BY, KG, KZ, MD, RU, TJ, TM), European patent (AT, BE, CH, CY, DE, DK, ES, FI, FR, GB, GR, IE, IT, LU, MC, NL, PT, SE), OAPI patent (BF, BJ, CF, CG, CI, CM, GA, GN, GW, ML, MR, NE, SN, TD, TG).</p> <p>Published Without international search report and to be republished upon receipt of that report.</p>	

(54) Title: PREDISTORTION LINEARIZER CIRCUIT

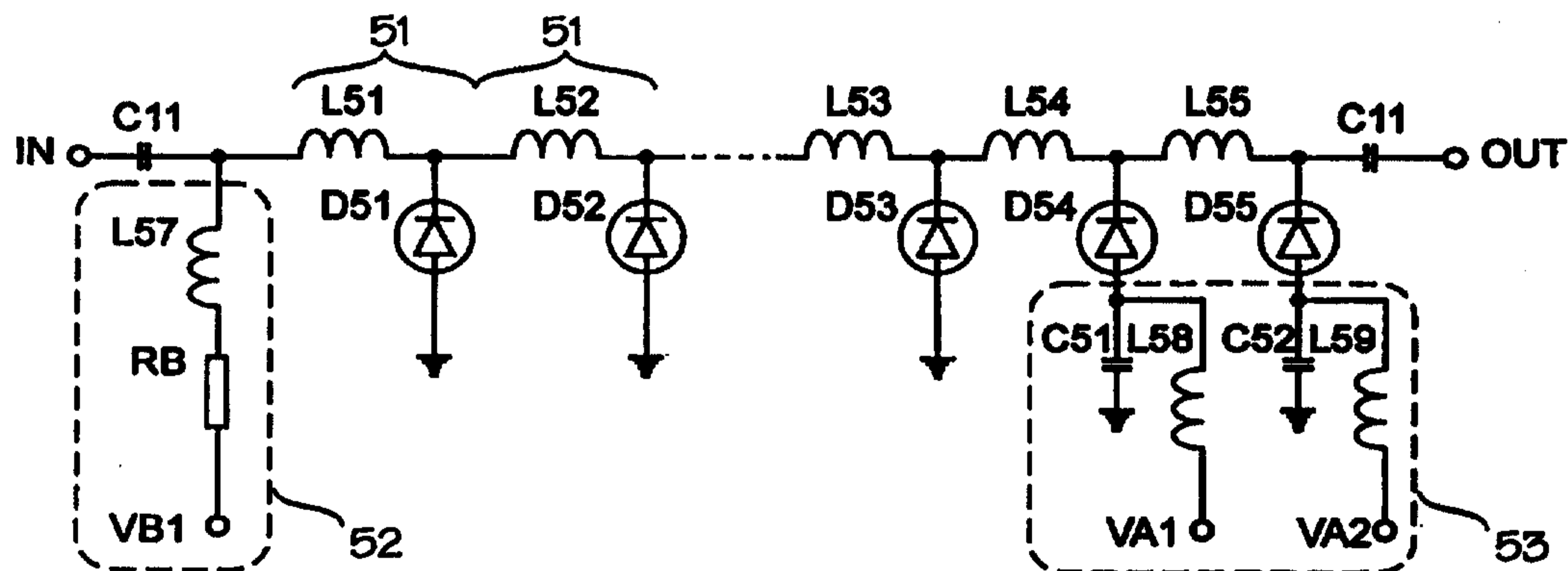

(57) Abstract

A predistortion linearizer circuit comprising an amplitude distorting part (AM/AM) and a phase distorting part (AM/PM). At least the phase distorting part (AM/PM) comprises broadband biasing means (51) and a non-linear transmission line (L51/D51 to L55/D55) responsive to them. The biasing means (51) are arranged to bias the non-linear transmission line (L51/D51 to L55/D55) to a substantially phase distorting area. The characteristics of the circuit can be changed by adjusting a biasing voltage (VB1) or by switching some of the diodes (D54, D55) inactive by activation signals (VA1, VA2). The amplitude distorting part (AM/AM) and the phase distorting part (AM/PM) can be similar in structure, but the diodes (D51 to D55) are partly forward-biased, whereby the losses caused by them decrease the amplitude of the signal.

PREDISTORTION LINEARIZER CIRCUIT

BACKGROUND OF THE INVENTION

The invention relates to a predistortion linearizer circuit and a method on which it is based. The predistortion linearizer circuit of the invention is primarily intended to be used to predistort the amplitude and phase of the input signal of a travelling wave tube amplifier in order to cancel the amplitude and phase distortion caused by the amplifier. To be more precise, the purpose of the predistortion linearizer circuit of the invention is that the third and fifth order intermodulation distortion, AM/AM and AM/PM response, AM/PM transition and noise/power ratio of the linearized travelling wave tube amplifier can be substantially minimized.

Prior art predistortion linearizer circuits have been implemented by means of one or two non-linear components (a diode or a transistor, for instance) and by dividing a signal into two branches: linear and non-linear. The former solution utilizes the increase of transmission loss or reflection of the non-linear component as a function of the input power. In the latter solution, the non-linear branch being compressed is added to the linear branch by an appropriate phase shift and amplitude. A predistortion linearizer circuit operating at a certain frequency can be formed in both ways. A predistortion linearizer circuit of this kind is disclosed in US Patent 4 752 743, for instance. A predistortion linearizer circuit PDL can be used in accordance with Figure 1, for example, to predistort the input signal of a travelling wave tube amplifier TWTA. The predistortion linearizer circuit consists of two main parts: an amplitude distorting part AM/AM and a phase distorting part AM/PM. (The two-part term AM/PM is meant to indicate that amplitude modulation of the input signal causes phase modulation (unit %/dB) of the output signal. In addition, the predistortion linearizer circuit PDL comprises a mechanism for inhibiting direct current (and a modulation frequency signal). In Figure 1, this kind of mechanism is a capacitor C11 coupled in series with the signal, but it can also be a transformer (not shown), etc.

The problem in the prior art predistortion linearizer circuits is that they operate only in a narrow frequency band. If the operating frequency is changed, the prior art predistortion linearizer circuits must be tuned to the new operating frequency. In other words, they are not sufficiently broadband.

BRIEF DESCRIPTION OF THE INVENTION

An object of the invention is to provide a predistortion linearizer circuit that operates in a broader frequency band than the prior art predistortion linearizer circuits. The objects of the invention can be achieved with a method and a predistortion linearizer circuit which are characterized by what is stated in the characterizing parts of the independent claims. The preferred embodiments of the invention are disclosed in the dependent claims.

The invention is based on the observation that the phase-frequency distortions of a non-linear transmission line with a certain transit time and biased by appropriate biasing means and of a travelling wave tube amplifier as a function of the input power are inversely related over a broad frequency band. The basis of the implementation of the invention is that at least the phase distorting part of the predistortion linearizer circuit comprises a non-linear transmission line and broadband biasing means for appropriately biasing the non-linear transmission line to an operating point changing with incoming amplitude modulation. In this connection, the broadband biasing means imply that at a modulation bandwidth their input impedance is designed to be suitable for detecting the modulation, but at a carrier frequency their input impedance is high. The structure is thus of the type of a low-pass filter. The transmission line comprises several stages, each comprising an inductance coupled in series with the signal and a capacitance coupled in parallel with the signal. In practice, the transmission line is formed by a component arrangement satisfying the characteristic transmission line equations known to those skilled in the art, as will be described below. The minimum number of the stages is two; in practice about 20 stages are necessary. A non-linear transmission line means that an inductance and/or a capacitance (in practice capacitance) changes as a function of the instantaneous voltage or current of an input signal. The carrier wave power must thus be detected and the transmission line voltage in the modulation band must be controlled by the detected signal. The practical implementation of the non-linear transmission line is usually an inductance in series with the signal and an appropriately biased semiconductor junction, such as a diode, in parallel with the signal.

The predistortion linearizer circuit of the invention is a broadband one. Its phase-frequency distortion in a broad frequency band is inverse to the phase-frequency distortion caused by a travelling wave tube. The propagation delay of the travelling wave tube becomes longer with the increase of the input

power, while the propagation delay of the predistortion linearizer circuit of the invention correspondingly becomes shorter, so the phase-frequency distortions of the predistortion linearizer circuit and travelling wave tube cancel each other out over the broad frequency band.

5 The active part of the predistortion linearizer circuit of the invention is an extremely simple non-linear transmission line. In practice the transmission line is implemented by two components, one of which can be merely a short bit of wire. This makes diverse modifications possible without making the whole circuit considerably more complex. The non-linear transmission line is
10 known from other contexts, so those skilled in the art can easily manage its implementation, design and behaviour.

BRIEF DESCRIPTION OF THE DRAWINGS

The invention is now described in closer detail in connection with preferred embodiments with reference to the accompanying drawings, in which
15 Figure 1 shows a schematic view of a predistortion linearizer circuit;
 Figures 2 to 3 show an equivalent circuit of a transmission line;
 Figure 4 shows an embodiment of an amplitude distorting part; and
 Figure 5 shows a suitable circuit for distorting both phase and amplitude.

20 DETAILED DESCRIPTION OF THE INVENTION

 Figure 2 shows an equivalent circuit of a transmission line. The transmission line with its equivalent circuits and designs is technique well known to those skilled in the art, but to use it in a predistortion linearizer circuit is novel. The transmission line comprises inductances L_s in series with the
25 signal and capacitances C_p coupled in parallel with the signal. A non-linear transmission line is formed in such a manner that the value of a capacitance C_p changes as a function of a voltage V_j across it, in other words $C_p = C(V_j)$. When the RF power of an input signal is detected by an appropriate technique, and the voltage V_j is controlled by the detected AM signal, the C_p can be de-
30 creased when the input power increases. In practice, the parallel capacitance C_p is implemented in a circuit by an appropriate semiconductor barrier, such as a PN junction, Schottky junction or PIN diode. All operations essential for non-linearity, i.e. the detection of the RF power, the control of the voltage V_j by means of broadband biasing means and the non-linear capacitance C_p , are
35 combined in this kind of junction. Any barrier or component whatsoever that

implements these three essential operations qualifies as a diode in the sense of the present application.

As is known, the characteristic impedance of a transmission line $Z_0 = \sqrt{Ls / Cp}$ and propagation coefficient $\gamma = \omega \sqrt{Ls Cp}$. A suitable coil or a short bit of any high impedance wire, such as a microstrip, for instance, may operate as a series inductance Ls . The characteristic impedance Z_0 is typically designed to be 50Ω .

Figure 3 shows the equivalent circuit of a transmission line in a situation where a detecting junction is biased to a conducting range. A conductance Gp , which causes losses in the line, is formed in parallel to capacitances Cp . The conductance Gp also depends on the voltage Vj across the junction. When the junction voltage Vj thus changes as the input power increases, the conductance Gp decreases and the attenuation of the line decreases. A non-linear transmission line thus distorts amplitude when biased in a certain manner, and when biased in another manner it distorts phase, in other words the propagation delay. Amplitude distortion also distorts the phase at the same time, but an appropriate phase and amplitude predistortion can be achieved by choosing appropriate phase and amplitude distortions and by placing a broadband amplifier between the parts.

Figure 4 shows an embodiment of an amplitude distorting part AM/AM. Amplitude distortion can be achieved by a diode $D41$ which is coupled in series with a signal and with which a parallel-resonant circuit comprising a capacitor $C41$ and an inductance $L41$ have been coupled in parallel. The inductance $L41$ is parallel-resonant with the (capacitive) reactance of the diode $D41$ in the circuit's operating frequency. This efficiently inhibits signal propagation through the reactive components of the circuit and thus inhibits the generation of phase distortion. The resistance of a resistor $R41$ lowers the Q factor of the resonance circuit and thus increases the operating frequency band of the circuit. The resistance determines the transmission loss of the circuit at a low input power, when the diode $D41$ does not conduct. The diode $D41$ is biased by an adjustable bias voltage $VB1 - VB2$ through coils $L42$ and $L43$, which inhibit the propagation of a radio frequency signal. When the input signal amplitude with the bias voltage added to it becomes higher than the threshold voltage of the forward conduct of the diode $D41$, the diode $D41$ starts conducting a certain part of the input signal cycles. The mean resistance during a cycle decreases and the attenuation of the propagating signal de-

creases as a function of the input power. This decrease of attenuation taking place as the function of the input power can be controlled by the bias voltage VB1 – VB2. In figure 4 two such parallel couplings 41 of a biased diode and a resonance circuit are coupled in series to ensure sufficient dynamic range. There can, of course, be more than two of them. In addition, broadband amplifiers can be coupled between and/or after the parts 41 in order to compensate for losses.

Figure 5 shows, as an embodiment of a circuit suitable for phase distortion (block AM/PM in Figure 1). The circuit of Figure 5 is based on the usage of an appropriately biased non-linear transmission line for predistorting a signal. The non-linear transmission line comprises several stages 51 formed by a series inductance and a parallel capacitance, as is shown in connection with Figures 2 and 3. In Figure 5, series inductances are coils L51 to L55, and parallel capacitances are capacitances C_p of diodes D51 to D55. The transmission line is biased by a bias voltage VB1 through a resistor RB and a coil L57. The dotted line between coils L52 and L53 illustrates the fact that more or fewer stages 51 formed by the series inductance and the parallel capacitance can be coupled in series than shown in Figure 5. The operation of these stages 51 is described in connection with Figures 2 and 3. The values of the series inductance and the parallel capacitance determine the characteristic impedance Z_0 and the propagation coefficient γ of the transmission line. The inductance and the capacitance must be sufficiently low to ensure that the cutoff frequency of a low-pass type line is clearly above the operating frequency. When the input power increases, the diodes D51 to D55 of the line start conducting, whereby the diodes change to be more reverse-biased on account of the voltage difference generated over the serial resistance RB of the bias line. This decreases the junction capacitance C_p of the diodes, whereby the propagation coefficient of the non-linear transmission line decreases and the electrical length of the line is shortened. The characteristics of the circuit can be adjusted by biasing, in other words by the bias voltage VB1 and/or by changing the value of the biasing resistor RB. The RB can be electrically or mechanically adjustable. The characteristics of the circuit can also be adapted by changing the number of active diodes. Reference number 53 indicates a mechanism for changing the number of active diodes. The diodes D54 and D55 have been isolated from ground by capacitors C51 and C52, respectively, and their bias voltages are applied through inductances L58 and

L59. The capacitors C51 and C52 are designed in such a manner that they ground the carrier wave frequency. The bias voltage sources are here called activation voltages VA1 and VA2 to emphasize the fact that the diodes D54 and D55 can be made entirely active or entirely inactive (as opposed to merely slightly adjusting the phase shift caused by them). If, for example, the activation voltage VA1 is sufficiently negative, the diode D54 is clearly reverse-biased at all input power values. The capacitance of the diode D54 is thus not changed as a function of the input power, and the change in the propagation coefficient of the line and in the electrical length as a function of the input power decrease. The advantage of this kind of circuit is that there is a wide range of possible configurations.

The circuit of Figure 5 can also be used for distorting the amplitude. This is performed by partly forward-biasing the diodes D51 to D55, as was described in connection with Figure 3.

A predistortion linearizer circuit PDL in accordance with Figure 1 can be implemented by coupling an amplitude distorting part of Figure 4 and a phase distortion circuit of Figure 5 in series. As an alternative to this arrangement, two circuits of Figure 5 can be coupled in series, the first circuit changing the amplitude and the second the phase (or vice versa). The diodes D51 to D55 of the phase changing circuit are reverse-biased and the diodes D51 to D55 of the amplitude changing circuit are partly forward-biased. The advantage of the latter arrangement is that the phase distorting part and the amplitude distorting part of the predistortion linearizer circuit are similar in structure, the different biasing being the only difference between them.

It will be obvious to those skilled in the art that the basic idea of the invention can be implemented in many ways. The invention and its embodiments are thus not restricted to the examples described above but they can vary within the scope of the claims.

CLAIMS

1. A method for predistorting a radio frequency input signal, in which method the flow of direct current and the propagation of a modulation frequency signal are inhibited, and the signal is subjected to amplitude and phase distortion, **characterized** in that the signal is applied through a non-linear transmission line at least during phase distortion and said non-linear transmission line is biased to a substantially phase distorting range.
2. A predistortion linearizer circuit (PDL) for predistorting a radio frequency input signal, comprising means (C11) for inhibiting direct current and modulation frequency, and comprising an amplitude distorting part (AM/AM) and a phase distorting part (AM/PM), **characterized** in that at least the phase distorting part (AM/PM) comprises broadband biasing means (52) and a non-linear transmission line (51) responsive to them, and
- the biasing means (52) are arranged to bias the non-linear transmission line (51) to a substantially phase distorting range.
3. A predistortion linearizer circuit as claimed in claim 2, **characterized** in that the non-linear transmission line (51) comprises an inductance (L51) coupled in series with the signal and a diode (D51) coupled in parallel with the signal.
4. A predistortion linearizer circuit as claimed in claim 3, **characterized** in that the non-linear transmission line (51) comprises several inductances (L51 to L55) and several diodes (D51 to D55) and means (53) by which some of the diodes (D54 – D55) can be switched inactive.
5. A predistortion linearizer circuit as claimed in claim 4, **characterized** in that the means (53) by which some of the diodes can be switched inactive comprise a capacitance (C51, C52) isolating each diode (D54, D55) to be switched from ground, and means (VA1, VA2, L58, L59) for strongly reverse-biasing said diode.
6. A predistortion linearizer circuit as claimed in any one of claims 2 to 5, **characterized** in that the amplitude distorting part (AM/AM) comprises at least one stage (41) comprising a diode (D41) with its biasing means (VB1, VB2, L42, L43) coupled in series with the signal and a parallel-resonant circuit (L41, C41) coupled in parallel with the diode and comprising a resistance (R41) lowering its Q factor.

7. A predistortion linearizer circuit as claimed in claim 6, **characterized** in that it comprises several substantially similar stages (41) that are coupled in series.

5 8. A predistortion linearizer circuit as claimed in any one of claims 2 to 5, **characterized** in that the amplitude distorting part (AM/AM) is substantially similar in structure to said phase distorting part (AM/PM), but said non-linear transmission line (51) is biased to a substantially phase distorting range.

10 9. A predistortion linearizer circuit as claimed in any one of claims 2 to 8, **characterized** in that it comprises several amplitude and/or phase distorting parts coupled in series, and amplifiers coupled between them.

10. Use of a non-linear transmission line biased to a substantially phase distorting range for predistorting the phase of a radio frequency signal.

1/1

Fig. 1
(PRIOR ART)

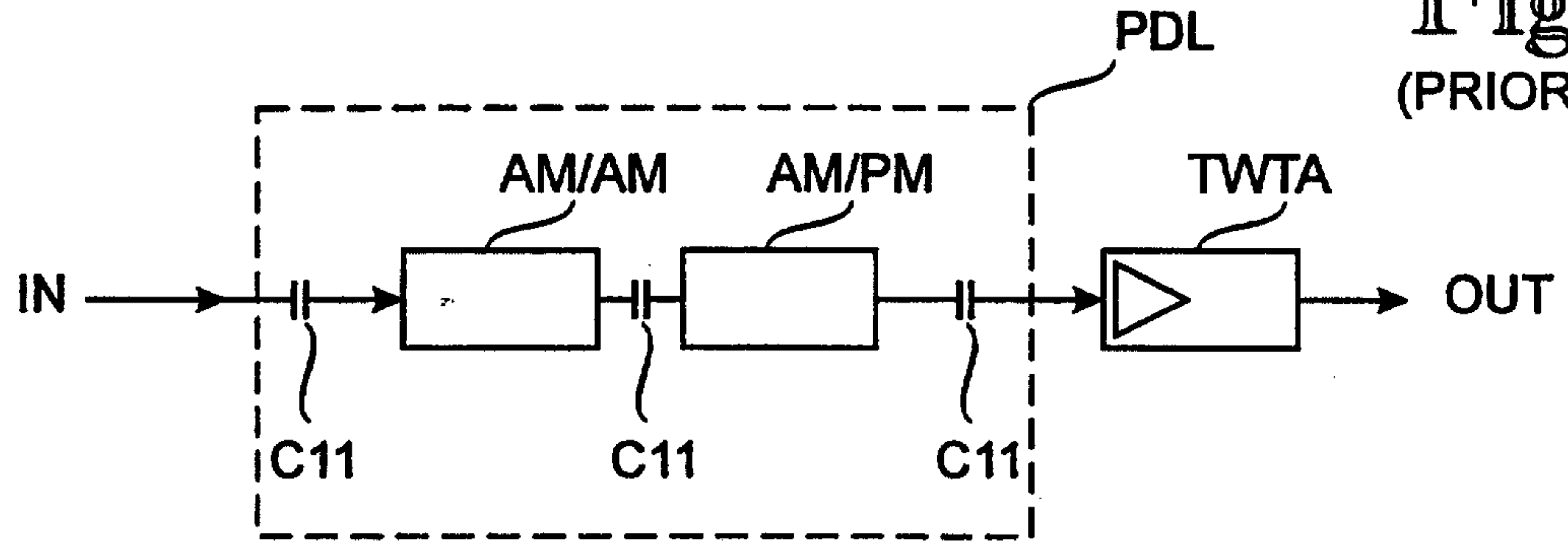

Fig. 2

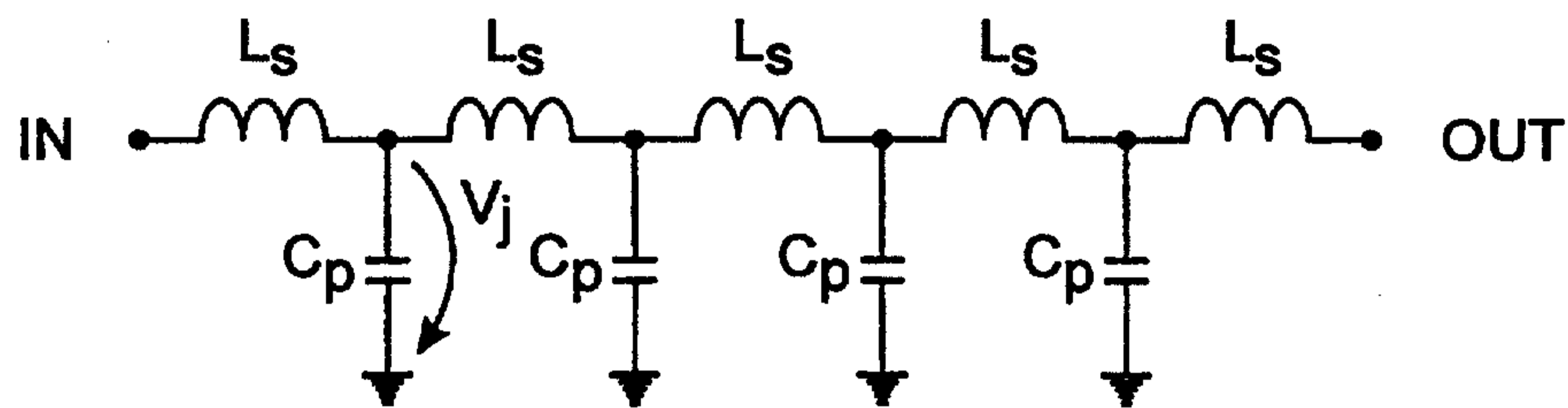

Fig. 3

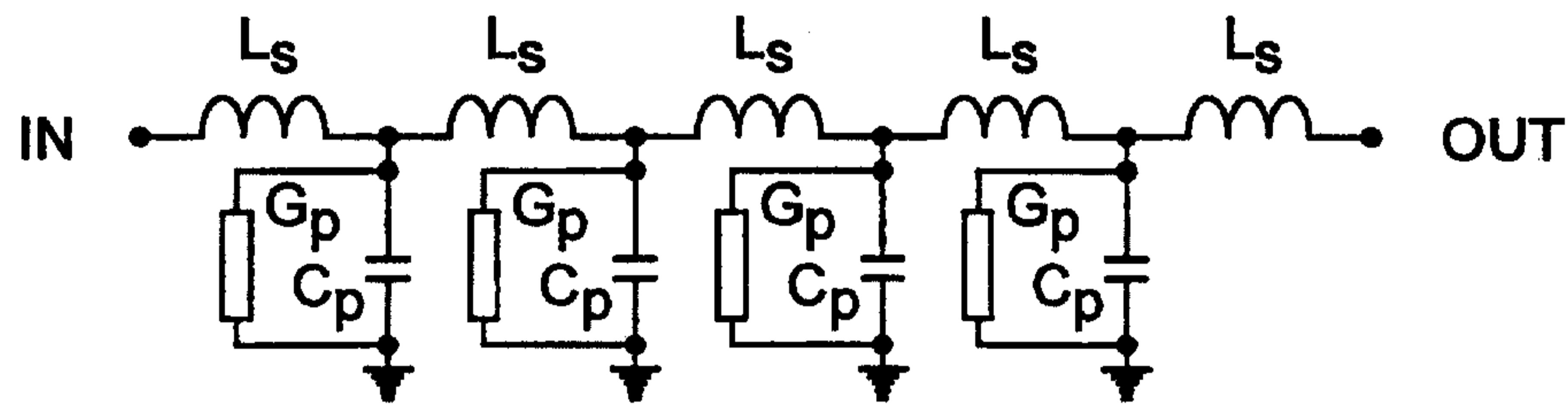

Fig. 4

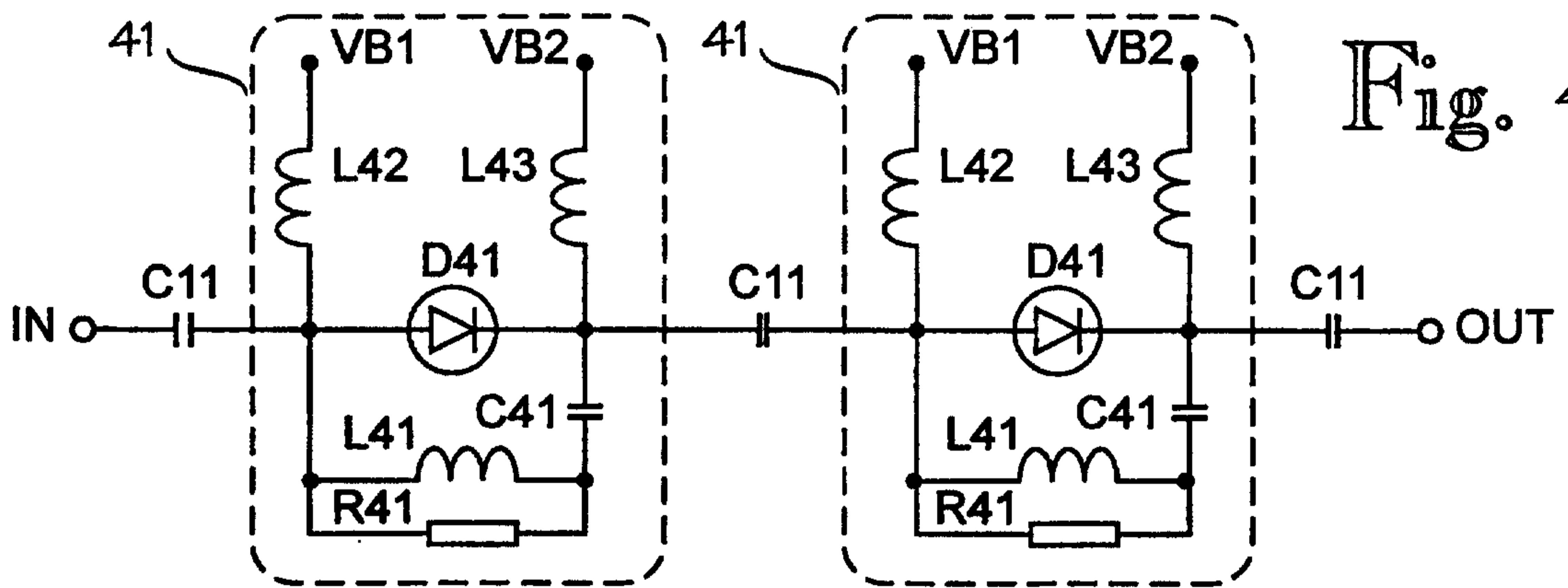

Fig. 5

