

C. VAN HOASEN.

Improvement in Sash-Balances.

No. 114,729.

Patented May 9, 1871.

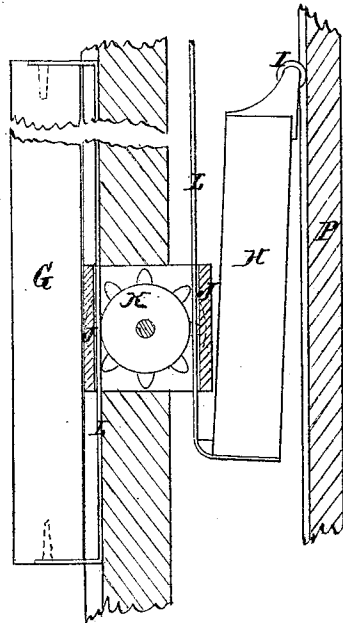
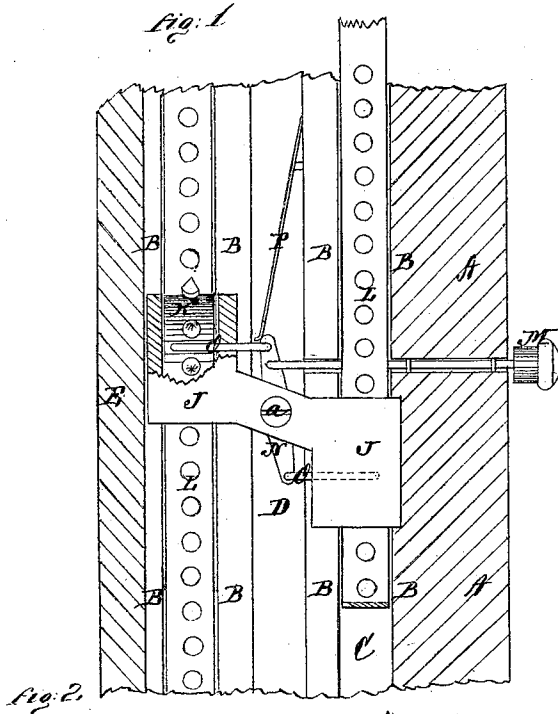

Witnesses.

C. L. Covert.
A. A. Yeatman

Inventor.

Casper Van Hoasen
per
Alexander Mason

Atty-

United States Patent Office.

CASPER VAN HOUSEN, OF CATSKILL, NEW YORK.

Letters Patent No. 114,729, dated May 9, 1871.

IMPROVEMENT IN SASH-BALANCES.

The Schedule referred to in these Letters Patent and making part of the same.

To all whom it may concern:

Be it known that I, CASPER VAN HOUSEN, of Catskill, in the county of Greene and in the State of New York, have invented certain new and useful Improvements in Sash and Weight Attachment and Lock; and do hereby declare that the following is a full, clear, and exact description thereof, reference being had to the accompanying drawing and to the letters of reference marked thereon making a part of this specification.

The nature of my invention consists in combining perforated metallic strips arranged with the sash and weight, and operated by toothed wheels placed in frames between the sash and window-frame, the said weights running in guides and being provided with friction-rollers; also, in the construction of the locking device for holding the sash, as will be more fully hereinafter set forth.

In order to enable others skilled in the art to which my invention appertains to make and use the same, I will now proceed to describe its construction and operation, referring to the annexed drawing, in which—

Figure 1 is a front or face view of a side of a window-frame representing my sash-balance and lock in position, the sash, parting-strip, and front-stop being removed.

Figure 2 is a side cross-section view of the entire arrangement.

A represents the position of the front-stop of a window.

B B, the pulley-stile or side of window-frame, against which the side of the sash or sash-stile slides.

C C are shallow grooves about one-quarter inch deep and five-eighths wide, cut the entire length of the pulley-stile B, and in a line with the center of the pulleys or wheels.

D is the deep groove in the pulley-stile for parting-strip, which may be dispensed with in this arrangement if so desired.

E is the back or outer stop.

F is a thin backing-piece to the weight-case.

G is the sash-stile.

H is the weight, having secured to its upper end a friction-roller, I, as seen in fig. 2, which rolls against or in a shallow channel cut in the surface of said backing-piece F, and so guiding the upper end of the said weight.

J J are the pulleys or wheel-frames, which are let in the pulley-stile or side of the window-frame even with its face-surface, and in center line with the grooves C C, being in line with the sash-way.

Two of said pulleys or wheel-frames are shown in fig. 1, being one for each sash, and joined together in one by a connecting-bar which has a hole in its center, through which is passed a wood screw, a, entering in

the solid wood of the window-frame at the bottom of the parting-strip groove D, thus holding said wheel-frames securely in place.

K K are the rounded and pointed tooth-wheels, which rest and turn on their axis in said frames J J.

These frames have slots in their front and back plates, as shown, in which the ends of the pin-cogs of the wheels pass, scribing a circle when said wheels are turned.

L L are metallic strips about five-eighths of an inch wide and from one-thirty-second to one-sixteenth of an inch thick, which have a row of holes punched in them to correspond with and work on the pin-cogs of the wheels K K.

These perforated metallic strips are confined and pass freely up and down between the body of said wheel and the inner surface of the wheel-frame's front and back slotted plates.

There are two strips used in connection with each wheel, one on each side. The one on the outside, which slides in shallow grooves O in the pulley-stile B, and between it and the sash-stile G, has its ends bent over and screwed to the top and bottom of the sash, as shown. The other or inner metallic perforated strip has its lower end bent under and hooked on the hooking-pin b, at the lower end of the weight H. The upper end of this strip may be free or guided by a wire or other suitable means.

M is a knob attached to one end of a wire rod, the other end of which is attached to one side of an evener or lever, N, which turns on the shank of the screw a.

This lever N is placed behind the bar which connects the two wheel-frames J J, and within the parting-strip groove D, in which it freely plays under said strip.

At each end of the evener or lever N is attached a small pin or bolt, O, of wire, which slides backward and forward in holes pierced in the front face-plate of the wheel-frames J, and across the slots seen in the same.

The wire pins O O, sliding in said holes across the slots in front of the perforated strips L L, and between the pin-teeth of the wheels K K, prevent the turning of said wheels and the consequent movement of the said strips, sash, and weights, thus completely and securely locking the windows.

P is a slight spring placed in the parting-strip groove, to act on the lever N to force the bolts O O inward and insure the locking. The unlocking is effected by pulling the knob M.

Having thus fully described my invention,

What I claim as new, and desire to secure by Letters Patent, is—

1. The combination of the perforated metallic strips L L, arranged respectively upon the sash and

weight, the wheels K K, and the weight H, when the latter is provided with a friction-roller and guide, all substantially as set forth.

2. The pulley-frames J J, when joined together, as described, in one, and secured to the pulley-stile by one screw, *a*, substantially as set forth.

3. The combination of the frames J J, pulleys or wheels-K K, strips L L, weight H with roller I, knob M, lever N, bolts O O, and spring P, substantially as and for the purposes herein set forth.

In testimony that I claim the foregoing, I have hereunto set my hand and seal this 18th day of October, 1870.

CASPER VAN HOUSEN. [L. s.]

Witnesses:

RUFUS H. KING,
JOSEPH HALLOCK.