

S. D. WHEELER.
AIRSHIP.
APPLICATION FILED DEC. 8, 1909.

1,001,721.

Patented Aug. 29, 1911.
2 SHEETS—SHEET 1.

Fig. 1.

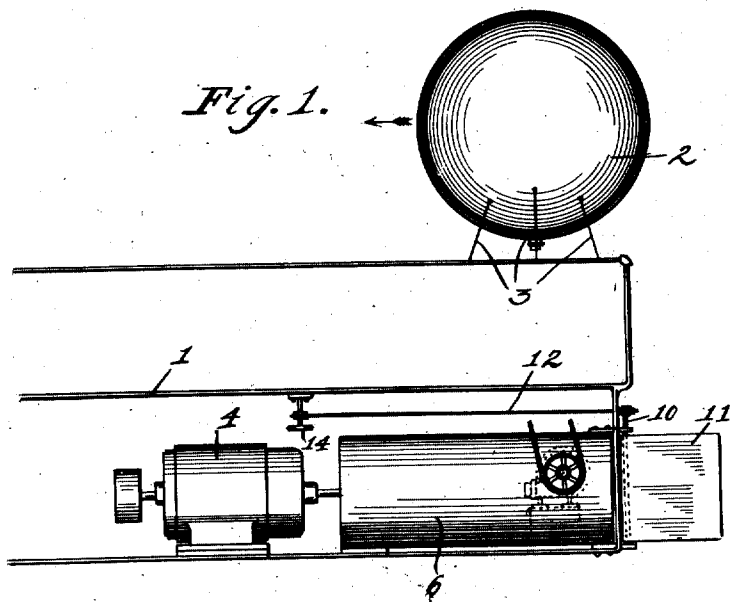
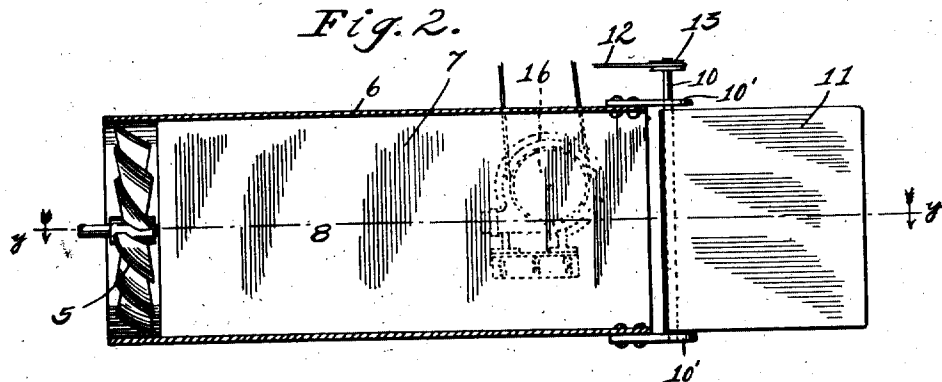

Fig. 2.



Witnesses:
C. E. Wessels.
A. A. Olson.

Inventor:
Samuel D. Wheeler,
By Joshua R. H. Fess
his Attorney.

1,001,721.

Patented Aug. 29, 1911.

2 SHEETS—SHEET 2.

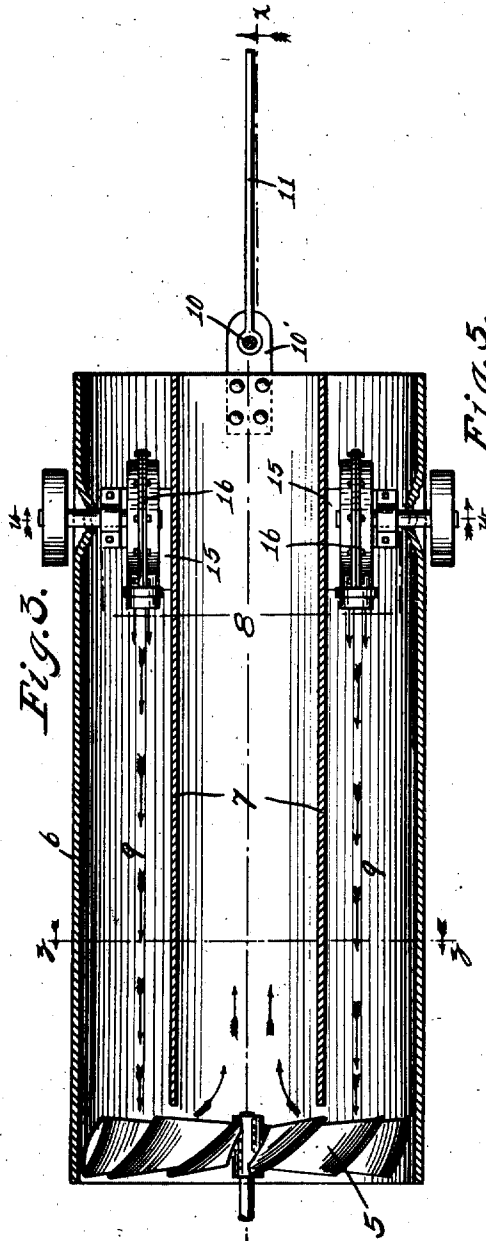

Fig. 3.

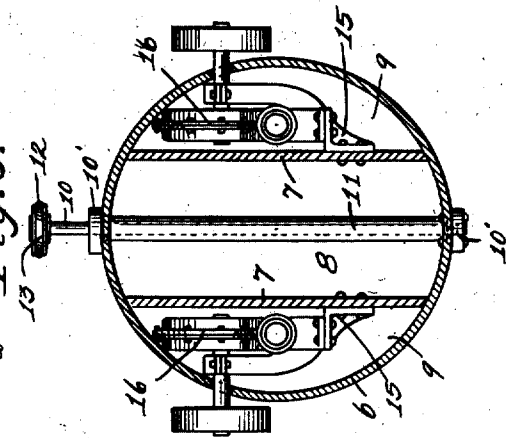

Fig. 5.

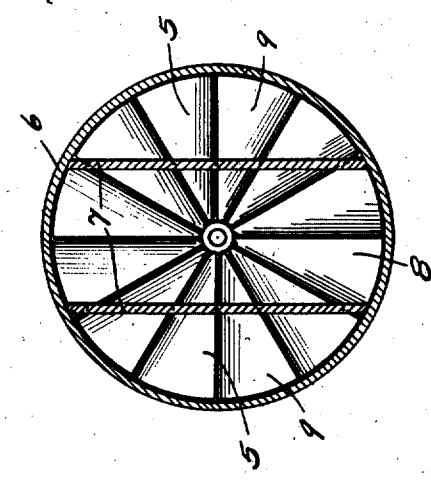

Fig. 1.

Witnesses:
E. E. Weissels.
A. A. Olson.

Inventor:
Samuel D. Wheeler,
By Joshua H. P. ...
his Attorney.

UNITED STATES PATENT OFFICE.

SAMUEL D. WHEELER, OF CHICAGO, ILLINOIS.

AIRSHIP.

1,001,721.

Specification of Letters Patent. Patented Aug. 29, 1911.

Application filed December 8, 1909. Serial No. 532,014.

To all whom it may concern:

Be it known that I, SAMUEL D. WHEELER, a citizen of the United States, residing at Chicago, county of Cook, and State of Illinois, have invented certain new and useful Improvements in Airships, of which the following is a specification.

My invention relates to air-ships and more specifically to propelling and steering means therefor.

The object of my invention is the provision of improved propelling and steering means for aerial craft which will render the latter applicable to travel at a greater rate of speed than is possible at the present time with air-ships of the present design, and which will make it possible to steer an air-ship with greater facility and accuracy.

A further object is the provision of improved propelling and steering mechanism as mentioned which will be of great effectiveness and which will be comparatively simple of construction.

Other objects will appear hereinafter.

With these objects in view my invention consists in improvements characterized as above mentioned and in certain details of construction and arrangement of parts all as will be hereinafter fully described and particularly pointed out in the appended claims.

My invention will be more readily understood by reference to the accompanying drawings forming a part of this specification, and in which,

Figure 1 is a side elevation of the rear end portion of an air-ship showing the arrangement of my device therein, Fig. 2 is a central longitudinal section of my device detached, taken on substantially the line $x-x$ of Fig. 3, Fig. 3 is a slightly enlarged longitudinal section taken on substantially the line $y-y$ of Fig. 2, and Figs. 4 and 5 are transverse sections taken on lines $z-z$ and $w-w$ of Fig. 3.

Referring now to the drawings, 1 represents the frame-work or body of an ordinary air-ship, 2 indicating one of the elevating gas bags therefor secured as by ropes 3 thereto. Mounted in the frame-work 1 adjacent the rearward end thereof is a motor 4, directly connected to which is the screw propeller 5 of the ship. Mounted rearward of the motor 4 in axial alinement with the power shaft thereof, is a cylindrical tube 6

open at both ends. Said tube is of a diameter slightly greater than that of the circle described by the propeller 5, the rearward extremity thereof enveloping said propeller as illustrated. Provided in said tube are two longitudinally extending vertically disposed partitions 7 substantially co-extensive in length therewith. Said partitions divide the interior of said tube into three passages, a central passage 8 and two similar outer passages 9. Having its stem 10 centrally mounted at the rearward extremity of said tube in diametrically opposed projecting bearings 10' arranged upon said rearward extremity of said tube is a vertically disposed rudder blade 11. 12 is the operating cord for said rudder, the same passing around a channel pulley 13 provided upon the upper extremity of the stem 10, and extending forwardly therefrom to and being operatively connected with a hand-wheel 14.

Mounted in each of the passages 9 upon brackets 15 arranged, upon the partitions 7, as shown, is a blower 16 of suitable design and driven by any suitable means carried in the ship frame-work. Said blowers are adapted to force air forwardly in the passages 9 into contact with the comprising blades of the propeller 5. With such provision, it is evident, that the air forced forwardly against the propeller blades increases the normal atmospheric resistance to said blades thereby necessarily proportionally increasing the propelling effectiveness of the same; it being clear, that the greater the atmospheric resistance to the rearward or operative surfaces of said blades the greater will be the propelling effectiveness thereof.

The air forced forwardly in the passages 9 will be forced rearwardly by the propeller through the passage 8, as indicated by arrows. Thus air is directed, as seen, to either side of the rudder blade, this increased draft upon the latter evidently increasing the effectiveness thereof and thereby making it possible to steer the ship with greater facility.

While I have shown what I deem to be the preferable form of my device I do not wish to be limited thereto as there might be various changes made in the details of construction and the arrangement of parts without departing from the spirit of the invention comprehended within the scope of the appended claims.

Having described my invention what I

claim as new and desire to secure by Letters Patent is:

1. In an air-ship, a propeller and a rudder arranged therein, in combination with a fixed tubular member interposed between said propeller and said rudder with its axis in alinement therewith, longitudinally extending partitions dividing the interior of said tubular member into a plurality of longitudinally extending passages, and means arranged in some of said passages for generating a draft and directing the same upon said propeller, substantially as described.
2. In an air-ship, a propeller and a rudder arranged therein, in combination with a fixed tubular member interposed between said propeller and said rudder with its axis in alinement therewith, said tubular member being open at both ends, longitudinally extending partitions dividing the interior of said tubular member into a plurality of longitudinally extending passages, and air blowers arranged in some of said passages adapted to direct currents of air toward said propeller, substantially as described.
3. In an air-ship, a propeller and a rudder arranged therein, in combination with a fixed tubular member interposed between said propeller and said rudder, longitudinally extending partitions dividing the interior of said tubular member into a plurality of longitudinally extending passages, only one of said passages communicating with said rudder, and means arranged in the remainder of said passages for generating air currents and directing the same toward said propeller, substantially as described.

4. In an air-ship, a propeller and a rudder arranged therein, in combination with a fixed tubular member interposed between said propeller and said rudder with its axis in alinement therewith, longitudinally extending vertical partitions dividing the interior of said tubular member into a plurality of longitudinally extending passages, the central one of said passages communicating with said rudder, and air blowers arranged in the remainder of said passages adapted to direct air currents toward said propeller, substantially as described.

5. In an air-ship, a screw propeller and a rudder arranged therein at the rearward end thereof, in combination with a fixed cylindrical tubular member interposed between said propeller and said rudder with its axis in alinement therewith, the forward end of said tubular member enveloping said propeller, two vertically disposed longitudinally extending partitions dividing the interior of said tubular member into three longitudinally extending passages, the central one of said passages communicating with said rudder, and an air blower arranged in each of the other passages adapted to direct an air current toward said propeller, substantially as described.

In testimony whereof I have signed my name to this specification in the presence of two subscribing witnesses.

SAMUEL D. WHEELER.

Witnesses:

JANET E. HOGAN,
JOSHUA R. H. POTTS.