



(11) **EP 1 992 795 A3**

(12) **EUROPEAN PATENT APPLICATION**

(88) Date of publication A3:  
**24.03.2010 Bulletin 2010/12**

(51) Int Cl.:  
**F01L 13/00<sup>(2006.01)</sup> F01L 1/18<sup>(2006.01)</sup>**

(43) Date of publication A2:  
**19.11.2008 Bulletin 2008/47**

(21) Application number: **08154624.4**

(22) Date of filing: **16.04.2008**

(84) Designated Contracting States:  
**AT BE BG CH CY CZ DE DK EE ES FI FR GB GR HR HU IE IS IT LI LT LU LV MC MT NL NO PL PT RO SE SI SK TR**  
Designated Extension States:  
**AL BA MK RS**

(72) Inventor: **Hendriksma, Nick J.**  
**Grand Rapids, MI 49546 (US)**

(74) Representative: **Denton, Michael John et al**  
**Delphi France SAS**  
**64 Avenue de la Plaine de France**  
**ZAC Paris Nord II**  
**B.P. 65059, Tremblay en France**  
**95972 Roissy Charles de Gaulle Cedex (FR)**

(30) Priority: **16.05.2007 US 803910**

(71) Applicant: **Delphi Technologies, Inc.**  
**Troy, Michigan 48007 (US)**

(54) **Two-step roller finger cam follower**

(57) A two-step roller finger follower assembly for shifting between high-lift and low-lift valve modes in a valve train of an internal combustion engine includes a body having side members defining coaxially disposed shaft orifices, a pallet end, a socket end, a slider arm aperture, and a latch pin channel. The socket end is mountable to a hydraulic lash adjuster, and the pallet end is matable with a valve stem. A slider arm for engaging

a high-lift cam lobe is disposed in the aperture, is pivotably mounted to a rotatable cross-shaft extending through the shaft orifices, and includes a slider tip for selectively engaging a latch pin to latch or unlatch the slider arm from the body. Dual rollers on the cross-shaft follow dual low-lift cam lobes. Preferably, the slider arm has a compound radial surface to provide compound lost motion of the slider arm, thereby minimizing rotational inertia.

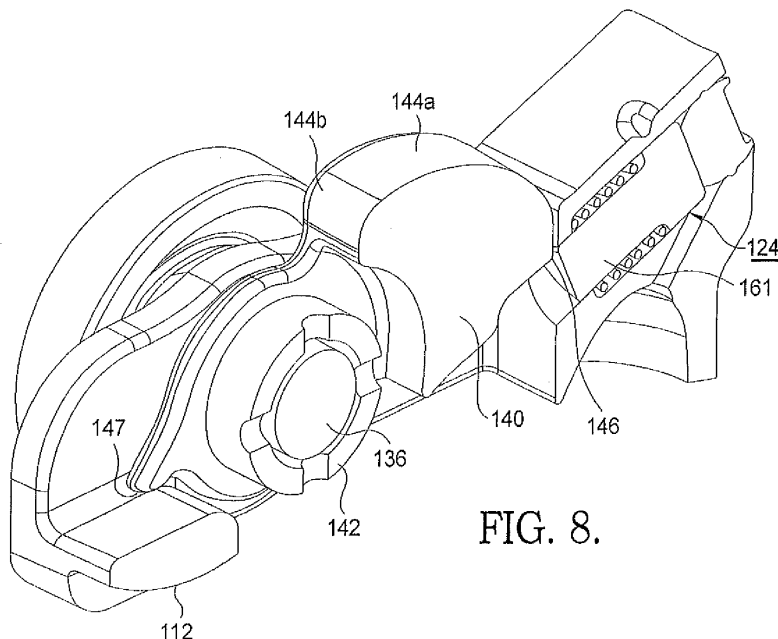

**FIG. 8.**

**EP 1 992 795 A3**



EUROPEAN SEARCH REPORT

Application Number  
EP 08 15 4624

DOCUMENTS CONSIDERED TO BE RELEVANT			
Category	Citation of document with indication, where appropriate, of relevant passages	Relevant to claim	CLASSIFICATION OF THE APPLICATION (IPC)
D,X	WO 2007/035673 A (TIMKEN US CORP [US]; DEIERLEIN MATTHEW J [US]; LAIRD BRIAN [US]; MURPH) 29 March 2007 (2007-03-29)	1,2	INV. F01L13/00 F01L1/18
Y	* paragraphs [0039], [0040]; figures 1-4 *	3,4	
X	WO 2005/093224 A (TIMKEN US CORP [US]; MURPHY RICHARD F [US]; DEIERLEIN MATTHEW J [US]) 6 October 2005 (2005-10-06)	1,2	
Y	* figures 1-4 *	3,4	
Y	EP 1 338 760 A (DELPHI TECH INC [US]) 27 August 2003 (2003-08-27)	3,4	
Y	US 2004/103869 A1 (HARRIS WAYNE S [US]) 3 June 2004 (2004-06-03)	3,4	
			TECHNICAL FIELDS SEARCHED (IPC)
			F01L
<del>The present search report has been drawn up for all claims</del>			
Place of search Munich		Date of completion of the search 16 October 2009	Examiner Clot, Pierre
CATEGORY OF CITED DOCUMENTS X : particularly relevant if taken alone Y : particularly relevant if combined with another document of the same category A : technological background O : non-written disclosure P : intermediate document		T : theory or principle underlying the invention E : earlier patent document, but published on, or after the filing date D : document cited in the application L : document cited for other reasons ..... & : member of the same patent family, corresponding document	

1  
EPO FORM 1503 03.02 (P04C01)



Application Number

EP 08 15 4624

**CLAIMS INCURRING FEES**

The present European patent application comprised at the time of filing claims for which payment was due.

- Only part of the claims have been paid within the prescribed time limit. The present European search report has been drawn up for those claims for which no payment was due and for those claims for which claims fees have been paid, namely claim(s):
- No claims fees have been paid within the prescribed time limit. The present European search report has been drawn up for those claims for which no payment was due.

**LACK OF UNITY OF INVENTION**

The Search Division considers that the present European patent application does not comply with the requirements of unity of invention and relates to several inventions or groups of inventions, namely:

see sheet B

- All further search fees have been paid within the fixed time limit. The present European search report has been drawn up for all claims.
- As all searchable claims could be searched without effort justifying an additional fee, the Search Division did not invite payment of any additional fee.
- Only part of the further search fees have been paid within the fixed time limit. The present European search report has been drawn up for those parts of the European patent application which relate to the inventions in respect of which search fees have been paid, namely claims:
- None of the further search fees have been paid within the fixed time limit. The present European search report has been drawn up for those parts of the European patent application which relate to the invention first mentioned in the claims, namely claims:  
see additional sheet(s)
- The present supplementary European search report has been drawn up for those parts of the European patent application which relate to the invention first mentioned in the claims (Rule 164 (1) EPC).

**LACK OF UNITY OF INVENTION  
SHEET B**Application Number  
EP 08 15 4624

The Search Division considers that the present European patent application does not comply with the requirements of unity of invention and relates to several inventions or groups of inventions, namely:

## 1. claims: 1-4,13

A roller finger follower assembly whereby the first cam lobe is a low lift lobe and the second cam lobe is high lift lobe and comprising two rollers for following two of the low lift cam lobes resp. an internal combustion engine including such assembly.

---

## 2. claims: 5,6

A roller finger follower assembly including a bushing.

---

## 3. claims: 7,8

A roller finger follower assembly wherein the slider arm surface is a compound surface.

---

## 4. claim: 9

A roller finger follower assembly comprising a rotational limiter

---

## 5. claim: 10

A roller finger follower assembly comprising a bias spring grounded to the body and the slider arm.

---

## 6. claims: 11,12

A camshaft engaging element comprising a slider surface having a compound surface.

---

**ANNEX TO THE EUROPEAN SEARCH REPORT  
ON EUROPEAN PATENT APPLICATION NO.**

EP 08 15 4624

This annex lists the patent family members relating to the patent documents cited in the above-mentioned European search report. The members are as contained in the European Patent Office EDP file on  
The European Patent Office is in no way liable for these particulars which are merely given for the purpose of information.

16-10-2009

Patent document cited in search report	Publication date	Patent family member(s)	Publication date
WO 2007035673 A	29-03-2007	EP 1934436 A2	25-06-2008
		JP 2009509081 T	05-03-2009
		US 2008245330 A1	09-10-2008
-----			
WO 2005093224 A	06-10-2005	EP 1725744 A1	29-11-2006
		JP 2007526423 T	13-09-2007
		US 2008149059 A1	26-06-2008
-----			
EP 1338760 A	27-08-2003	JP 4330356 B2	16-09-2009
		JP 2003254024 A	10-09-2003
		US 2003159666 A1	28-08-2003
-----			
US 2004103869 A1	03-06-2004	NONE	
-----			