

(19)



Europäisches Patentamt
European Patent Office
Office européen des brevets



(11)

EP 1 265 203 A3

(12)

EUROPEAN PATENT APPLICATION

(88) Date of publication A3:
23.02.2005 Bulletin 2005/08

(51) Int Cl.7: **G07G 1/00, G07F 9/06,
E05G 1/02, G07D 11/00**

(43) Date of publication A2:
11.12.2002 Bulletin 2002/50

(21) Application number: **02253718.7**

(22) Date of filing: **27.05.2002**

(84) Designated Contracting States:
**AT BE CH CY DE DK ES FI FR GB GR IE IT LI LU
MC NL PT SE TR**
Designated Extension States:
AL LT LV MK RO SI

(72) Inventor: **Ross, John**
Seaford, East Sussex, BN25 2QD (GB)

(74) Representative: **Leckey, David Herbert et al**
Frank B. Dehn & Co.,
European Patent Attorneys,
179 Queen Victoria Street
London EC4V 4EL (GB)

(30) Priority: **05.06.2001 GB 0113689**

(71) Applicant: **Cash Bases Ltd.**
Newhaven, East Sussex BN9 0LA (GB)

(54) **Cash storage unit**

(57) The invention relates to a highly secure cash storage unit 10 for containing coins, bank notes, card transaction slips, coupons etc. and to a cash register or a retail checkout system comprising such a cash storage unit. The cash storage unit 10 comprises a base, a

lid 20 and a locking means for locking the lid in a closed position and may further comprise a drawer for storing cash. The lid 20 and/or the base are deformable such that, when force is used to try to move the lid 20 from the closed position to the open position the lid 20 and base engage to retain the lid in the closed position.

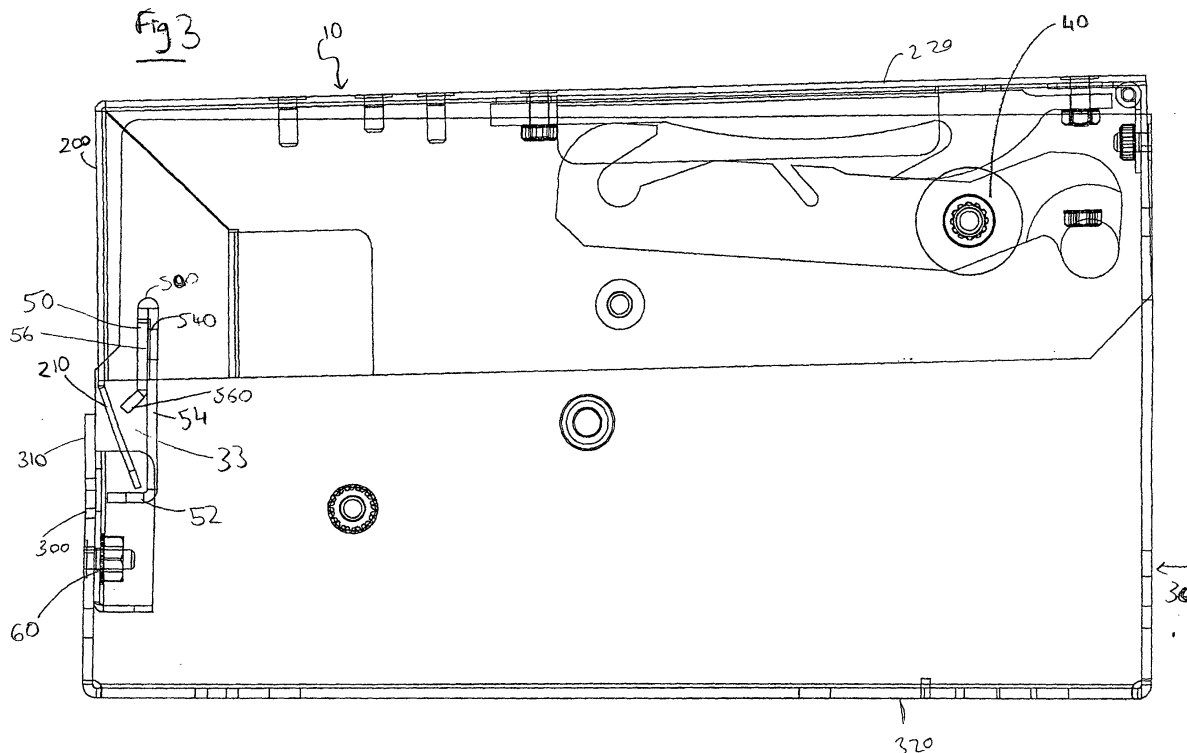

EP 1 265 203 A3



European Patent
Office

EUROPEAN SEARCH REPORT

Application Number
EP 02 25 3718

DOCUMENTS CONSIDERED TO BE RELEVANT			
Category	Citation of document with indication, where appropriate, of relevant passages	Relevant to claim	CLASSIFICATION OF THE APPLICATION (Int.Cl.7)
Y	EP 0 924 670 A (CASH BASES GB LTD) 23 June 1999 (1999-06-23) * abstract * * paragraph '0041! - paragraph '0042! * * figure 1 *	1-44	G07G1/00 G07F9/06 E05G1/02 G07D11/00
Y	US 4 725 084 A (CATRICOLA FRANK) 16 February 1988 (1988-02-16) * abstract * * figures 2,3 * * column 1, line 47 - column 2, line 14 *	1-44	
A	EP 0 637 674 A (INTELLECTUAL TRADE COMPANY S A) 8 February 1995 (1995-02-08) * abstract * * figure 1 * * figure 2 *	1-44	
A	DE 32 27 416 C (ADS ANKER GMBH) 19 January 1984 (1984-01-19) * column 2, line 60 - column 4, line 16 * * figure 1 *	1-44	
A,P	DE 100 05 074 A (WILLRICH PETER) 13 September 2001 (2001-09-13) * abstract * * column 1, line 34 - line 53 * * figures 2-4 *	1-44	TECHNICAL FIELDS SEARCHED (Int.Cl.7) G07G G07D E05G G07F
A	AU 84598 91 A (DELVIC PTY LIMITED) 26 March 1992 (1992-03-26) * page 2, line 1 - line 8 * * page 2, line 17 - line 23 * * page 2, line 31 - page 3, line 10 * * figures 2A,2B *	1-44	
		-/--	
The present search report has been drawn up for all claims			
Place of search		Date of completion of the search	Examiner
The Hague		21 December 2004	Diepstraten, M
CATEGORY OF CITED DOCUMENTS			
X : particularly relevant if taken alone Y : particularly relevant if combined with another document of the same category A : technological background O : non-written disclosure P : intermediate document		T : theory or principle underlying the invention E : earlier patent document, but published on, or after the filing date D : document cited in the application L : document cited for other reasons & : member of the same patent family, corresponding document	

EPO FORM 1503 03/92 (P/94C01)



European Patent
Office

EUROPEAN SEARCH REPORT

Application Number
EP 02 25 3718

DOCUMENTS CONSIDERED TO BE RELEVANT			
Category	Citation of document with indication, where appropriate, of relevant passages	Relevant to claim	CLASSIFICATION OF THE APPLICATION (Int.Cl.7)
A	WO 01/14672 A (SIO YEOK SING) 1 March 2001 (2001-03-01) * abstract * * page 1, paragraph 3 * * figures 1,2 * -----	1-44	
			TECHNICAL FIELDS SEARCHED (Int.Cl.7)
The present search report has been drawn up for all claims			
Place of search		Date of completion of the search	Examiner
The Hague		21 December 2004	Diepstraten, M
CATEGORY OF CITED DOCUMENTS X : particularly relevant if taken alone Y : particularly relevant if combined with another document of the same category A : technological background O : non-written disclosure P : intermediate document T : theory or principle underlying the invention E : earlier patent document, but published on, or after the filing date D : document cited in the application L : document cited for other reasons & : member of the same patent family, corresponding document			

EPO FORM 1503 03 02 (F04C01)

ANNEX TO THE EUROPEAN SEARCH REPORT
ON EUROPEAN PATENT APPLICATION NO.

EP 02 25 3718

This annex lists the patent family members relating to the patent documents cited in the above-mentioned European search report. The members are as contained in the European Patent Office EDP file on
The European Patent Office is in no way liable for these particulars which are merely given for the purpose of information.

21-12-2004

Patent document cited in search report		Publication date	Patent family member(s)	Publication date
EP 0924670	A	23-06-1999	EP 0924670 A1	23-06-1999
US 4725084	A	16-02-1988	NONE	
EP 0637674	A	08-02-1995	LU 88391 A1	01-03-1995
			DE 69409307 D1	07-05-1998
			DE 69409307 T2	17-09-1998
			EP 0637674 A1	08-02-1995
DE 3227416	C	19-01-1984	DE 3227416 C1	19-01-1984
			DE 3249315 A1	02-02-1984
DE 10005074	A	13-09-2001	DE 10005074 A1	13-09-2001
AU 8459891	A	26-03-1992	AU 640046 B2	12-08-1993
WO 0114672	A	01-03-2001	SG 83743 A1	16-10-2001
			AU 6887500 A	19-03-2001
			CN 1371447 T	25-09-2002
			EP 1212503 A1	12-06-2002
			JP 2003507608 T	25-02-2003
			WO 0114672 A1	01-03-2001
			US 2004207216 A1	21-10-2004