



US011344774B2

(12) **United States Patent**
Parsons et al.

(10) **Patent No.:** **US 11,344,774 B2**

(45) **Date of Patent:** ***May 31, 2022**

(54) **GOLF CLUB HEADS AND METHODS TO MANUFACTURE GOLF CLUB HEADS**

(71) Applicant: **PARSONS XTREME GOLF, LLC**,
Scottsdale, AZ (US)

(72) Inventors: **Robert R. Parsons**, Scottsdale, AZ (US); **Bradley D. Schweigert**, Cave Creek, AZ (US); **Michael R. Nicolette**, Scottsdale, AZ (US)

(73) Assignee: **PARSONS XTREME GOLF, LLC**,
Scottsdale, AZ (US)

(*) Notice: Subject to any disclaimer, the term of this patent is extended or adjusted under 35 U.S.C. 154(b) by 0 days.

This patent is subject to a terminal disclaimer.

(21) Appl. No.: **17/138,797**

(22) Filed: **Dec. 30, 2020**

(65) **Prior Publication Data**

US 2021/0121747 A1 Apr. 29, 2021

Related U.S. Application Data

(63) Continuation-in-part of application No. 16/820,366, filed on Mar. 16, 2020, now Pat. No. 10,981,037, and (Continued)

(51) **Int. Cl.**

A63B 53/04 (2015.01)
A63B 60/02 (2015.01)
A63B 60/54 (2015.01)

(52) **U.S. Cl.**

CPC **A63B 53/0466** (2013.01); **A63B 53/04** (2013.01); **A63B 60/02** (2015.10); (Continued)

(58) **Field of Classification Search**

CPC **A63B 53/0433**; **A63B 53/045**; **A63B 2053/0491**; **A63B 53/0475**; (Continued)

(56) **References Cited**

U.S. PATENT DOCUMENTS

1,133,129 A 3/1915 Govan
1,269,745 A 6/1918 Robertson
(Continued)

FOREIGN PATENT DOCUMENTS

JP 2007136068 A 6/2007
JP 3158662 U 4/2010

OTHER PUBLICATIONS

PCT/US15/42484: International Search Report and Written Opinion dated Oct. 19, 2015 (12 Pages).

(Continued)

Primary Examiner — Sebastiano Passaniti

(57) **ABSTRACT**

Embodiments of golf club heads and methods to manufacture golf club heads are generally described herein. In one example, a golf club head may include a body portion having a toe portion, a heel portion, a top portion, a bottom portion, a rear portion, a first interior cavity portion, and a second interior cavity portion. The second interior cavity portion may include a filler material. Other examples and embodiments may be described and claimed.

20 Claims, 17 Drawing Sheets

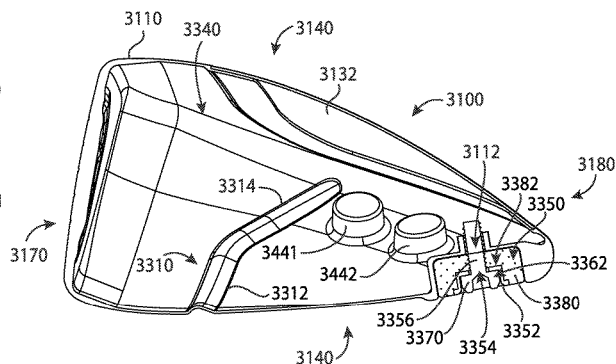
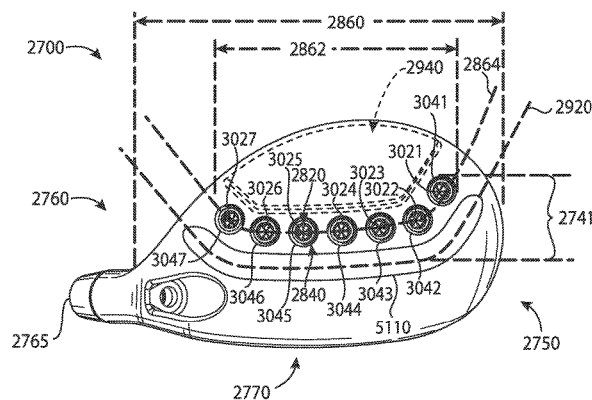

Related U.S. Application Data

a continuation-in-part of application No. 16/815,164, filed on Mar. 11, 2020, now abandoned, and a continuation-in-part of application No. 16/713,942, filed on Dec. 13, 2019, now Pat. No. 11,000,742, and a continuation-in-part of application No. 16/710,903, filed on Dec. 11, 2019, now Pat. No. 10,898,768, and a continuation of application No. 16/542,548, filed on Aug. 16, 2019, now Pat. No. 10,898,766, said application No. 16/710,903 is a continuation-in-part of application No. 16/539,397, filed on Aug. 13, 2019, now Pat. No. 10,786,712, said application No. 16/820,366 is a continuation of application No. 16/418,691, filed on May 21, 2019, now Pat. No. 10,653,928, and a continuation-in-part of application No. 16/375,553, filed on Apr. 4, 2019, now Pat. No. 10,695,623, said application No. 16/815,164 is a continuation of application No. 16/375,553, filed on Apr. 4, 2019, now Pat. No. 10,695,623, said application No. 16/820,366 is a continuation-in-part of application No. 16/372,009, filed on Apr. 1, 2019, now Pat. No. 10,821,334, and a continuation-in-part of application No. 16/290,610, filed on Mar. 1, 2019, now Pat. No. 10,617,918, said application No. 16/542,548 is a continuation-in-part of application No. 16/222,580, filed on Dec. 17, 2018, now Pat. No. 10,722,764, said application No. 16/713,942 is a continuation of application No. 16/198,128, filed on Nov. 21, 2018, now Pat. No. 10,532,257, said application No. 16/539,397 is a continuation of application No. 16/035,268, filed on Jul. 13, 2018, now Pat. No. 10,420,990, said application No. 16/710,903 is a continuation of application No. 15/994,860, filed on May 31, 2018, now Pat. No. 10,543,407, said application No. 16/542,548 is a continuation of application No. 15/967,098, filed on Apr. 30, 2018, now Pat. No. 10,420,989, said application No. 16/375,553 is a continuation of application No. 15/967,117, filed on Apr. 30, 2018, now Pat. No. 10,293,221, said application No. 16/372,009 is a continuation of application No. 15/875,416, filed on Jan. 19, 2018, now Pat. No. 10,293,220, said application No. 16/290,610 is a continuation of application No. 15/875,496, filed on Jan. 19, 2018, now Pat. No. 10,252,123, said application No. 16/222,580 is a continuation of application No. 15/831,148, filed on Dec. 4, 2017, now Pat. No. 10,195,501, said application No. 15/994,860 is a continuation of application No. 15/807,201, filed on Nov. 8, 2017, now Pat. No. 10,010,770, said application No. 16/418,691 is a continuation of application No. 15/803,157, filed on Nov. 3, 2017, now Pat. No. 10,335,645, said application No. 16/035,268 is a continuation of application No. 15/725,900, filed on Oct. 5, 2017, now Pat. No. 10,052,532, said application No. 15/967,098 is a continuation of application No. 15/687,273, filed on Aug. 25, 2017, now Pat. No. 9,981,160, said application No. 16/198,128 is a continuation of application No. 15/583,756, filed on May 1, 2017, now Pat. No. 10,143,899, said application No. 15/807,201 is a continuation of application No. 15/463,306, filed on Mar. 20, 2017, now Pat. No. 9,821,200, said application No. 15/967,117 is a continuation of application No. 15/457,618, filed on Mar. 13, 2017, now Pat. No. 9,987,526, said application No. 15/875,496 is a continuation of application No.

15/457,627, filed on Mar. 13, 2017, now Pat. No. 9,895,583, said application No. 15/831,148 is a continuation of application No. 15/453,701, filed on Mar. 8, 2017, now Pat. No. 9,833,667, said application No. 15/875,416 is a continuation of application No. 15/446,842, filed on Mar. 1, 2017, now Pat. No. 9,895,582, said application No. 15/725,900 is a continuation of application No. 15/445,253, filed on Feb. 28, 2017, now Pat. No. 9,795,843, said application No. 15/446,842 is a continuation of application No. 15/377,120, filed on Dec. 13, 2016, now Pat. No. 9,802,087, said application No. 15/803,157 is a continuation of application No. 15/290,859, filed on Oct. 11, 2016, now Pat. No. 9,814,945, said application No. 15/583,756 is a continuation of application No. 15/271,574, filed on Sep. 21, 2016, now Pat. No. 9,669,270, said application No. 15/463,306 is a continuation of application No. 15/249,857, filed on Aug. 29, 2016, now Pat. No. 9,630,070, said application No. 15/445,253 is a continuation of application No. 15/227,281, filed on Aug. 3, 2016, now Pat. No. 9,782,643, said application No. 15/457,627 is a continuation of application No. 15/189,806, filed on Jun. 22, 2016, now Pat. No. 9,636,554, said application No. 15/457,618 is a continuation of application No. 15/163,393, filed on May 24, 2016, now Pat. No. 9,662,547, said application No. 15/290,859 is a continuation of application No. 15/040,892, filed on Feb. 10, 2016, now Pat. No. 9,550,096, said application No. 15/377,120 is a continuation of application No. 14/939,849, filed on Nov. 12, 2015, now Pat. No. 9,555,295, said application No. 15/189,806 is a continuation of application No. 14/667,546, filed on Mar. 24, 2015, now Pat. No. 9,399,158, said application No. 15/163,393 is a continuation of application No. 14/667,541, filed on Mar. 24, 2015, now Pat. No. 9,352,197, which is a continuation-in-part of application No. 14/615,606, filed on Feb. 6, 2015, now Pat. No. 9,199,140, said application No. 14/939,849 is a continuation of application No. 14/615,606, filed on Feb. 6, 2015, now Pat. No. 9,199,140, said application No. 14/667,546 is a continuation-in-part of application No. 14/615,606, filed on Feb. 6, 2015, now Pat. No. 9,199,140.

(60) Provisional application No. 62/380,727, filed on Aug. 29, 2016, provisional application No. 62/362,491, filed on Jul. 14, 2016, provisional application No. 62/361,988, filed on Jul. 13, 2016, provisional application No. 62/360,802, filed on Jul. 11, 2016, provisional application No. 62/356,539, filed on Jun. 30, 2016, provisional application No. 62/337,184, filed on May 16, 2016, provisional application No. 62/301,756, filed on Mar. 1, 2016, provisional application No. 62/296,506, filed on Feb. 17, 2016, provisional application No. 62/291,793, filed on Feb. 5, 2016, provisional application No. 62/281,639, filed on Jan. 21, 2016, provisional application No. 62/195,211, filed on Jul. 21, 2015, provisional application No. 62/194,135, filed on Jul. 17, 2015, provisional application No. 62/184,757, filed on Jun. 25, 2015, provisional application No. 62/138,918, filed on Mar. 26, 2015, provisional application No. 62/120,760, filed on Feb. 25, 2015, provisional application No. 62/115,024, filed on Feb. 11, 2015, provisional application No. 62/109,510, filed on Jan.

29, 2015, provisional application No. 62/105,123, filed on Jan. 19, 2015, provisional application No. 62/101,543, filed on Jan. 9, 2015, provisional application No. 62/048,693, filed on Sep. 10, 2014, provisional application No. 62/042,155, filed on Aug. 26, 2014.

(52) **U.S. Cl.**

CPC *A63B 53/0408* (2020.08); *A63B 53/0412* (2020.08); *A63B 53/0433* (2020.08); *A63B 60/54* (2015.10); *A63B 2053/0491* (2013.01)

(58) **Field of Classification Search**

CPC . *A63B 53/0466*; *A63B 53/04*; *A63B 53/0408*; *A63B 60/54*; *A63B 60/02*; *A63B 53/0412*
 USPC 473/332, 334–339, 341, 343, 344, 345, 473/346, 350

See application file for complete search history.

(56)

References Cited

U.S. PATENT DOCUMENTS

1,306,029 A 6/1919 Robertson
 D55,867 S 7/1920 Matters
 1,534,600 A 4/1925 Mattern
 1,538,312 A 5/1925 Neish
 D138,437 S 8/1944 Link
 D138,438 S 8/1944 Link
 D138,442 S 8/1944 Link
 3,652,094 A 3/1972 Glover
 D240,748 S 7/1976 Bock et al.
 4,085,934 A 4/1978 Churchward
 D253,773 S 12/1979 Bieger
 D307,783 S 5/1990 Iinuma
 5,106,094 A 4/1992 Desbiolles et al.
 D326,885 S 6/1992 Paul
 5,219,408 A 6/1993 Sun
 D351,883 S 10/1994 Solheim et al.
 5,499,819 A 3/1996 Nagamoto
 5,518,243 A 5/1996 Redman
 D378,111 S 2/1997 Parente et al.
 D384,120 S 9/1997 Cruz et al.
 5,788,584 A 8/1998 Parente et al.
 D400,625 S 11/1998 Kubica et al.
 D400,627 S 11/1998 Kubica et al.
 D405,489 S 2/1999 Kubica et al.
 D405,492 S 2/1999 Kubica et al.
 5,997,415 A 12/1999 Wood
 D444,830 S 7/2001 Kubica et al.
 6,290,609 B1 9/2001 Takeda
 6,306,048 B1 10/2001 McCabe et al.
 6,409,612 B1 6/2002 Evans et al.
 6,533,679 B1 3/2003 McCabe et al.
 D478,140 S 8/2003 Burrows
 6,638,182 B2 10/2003 Kosmatka
 6,773,360 B2 8/2004 Willett et al.
 D508,969 S 8/2005 Hasebe
 D513,051 S 12/2005 Barez et al.
 D514,179 S 1/2006 Chen et al.
 D514,185 S 1/2006 Barez et al.
 6,991,560 B2 1/2006 Tseng
 D520,586 S 5/2006 Bingman
 D522,077 S 5/2006 Schweigert et al.
 D522,601 S 6/2006 Schweigert et al.
 D523,498 S 6/2006 Chen et al.
 D526,694 S 8/2006 Schweigert et al.
 7,083,530 B2 8/2006 Wahl et al.
 7,121,956 B2 10/2006 Lo
 D534,599 S 1/2007 Barez et al.
 7,166,040 B2 1/2007 Hoffman et al.
 D536,401 S 2/2007 Kawami
 D536,403 S 2/2007 Kawami
 D536,498 S 2/2007 Presnell
 7,186,190 B1 3/2007 Beach et al.
 7,223,180 B2 5/2007 Willett et al.

D563,498 S 3/2008 Jertson et al.
 D564,054 S 3/2008 Jertson et al.
 D564,055 S 3/2008 Jertson et al.
 7,338,388 B2 3/2008 Schweigert et al.
 7,347,794 B2 3/2008 Schweiger
 D566,934 S 4/2008 Valle
 D567,317 S 4/2008 Jertson et al.
 D569,933 S 5/2008 Jertson et al.
 D569,934 S 5/2008 Jertson et al.
 D569,935 S 5/2008 Schweigert et al.
 D569,936 S 5/2008 Schweigert et al.
 D569,942 S 5/2008 Jertson et al.
 D570,937 S 6/2008 Schweigert et al.
 D570,938 S 6/2008 Jertson et al.
 7,407,447 B2 8/2008 Beach et al.
 7,410,425 B2 8/2008 Willett et al.
 7,410,426 B2 8/2008 Willett et al.
 7,419,441 B2 9/2008 Hoffman et al.
 7,448,963 B2 11/2008 Beach et al.
 7,448,964 B2 11/2008 Schweigert et al.
 7,530,904 B2 5/2009 Beach et al.
 D594,520 S 6/2009 Schweigert et al.
 D594,521 S 6/2009 Jertson et al.
 D594,919 S 6/2009 Schweigert et al.
 7,540,811 B2 6/2009 Beach et al.
 D597,620 S 8/2009 Taylor et al.
 7,568,985 B2 8/2009 Beach et al.
 7,572,193 B2* 8/2009 Yokota A63B 53/0466
 473/328
 7,578,753 B2 8/2009 Beach et al.
 D600,297 S 9/2009 Jertson et al.
 7,584,531 B2 9/2009 Schweigert et al.
 7,588,502 B2 9/2009 Nishino
 7,591,738 B2 9/2009 Beach et al.
 D603,472 S 11/2009 Schweigert et al.
 7,611,424 B2 11/2009 Nagai et al.
 7,621,823 B2 11/2009 Beach et al.
 D605,715 S 12/2009 Barez et al.
 7,632,194 B2 12/2009 Beach et al.
 7,658,666 B2 2/2010 Sung
 7,713,142 B2 5/2010 Hoffman et al.
 7,717,804 B2 5/2010 Beach et al.
 7,717,805 B2 5/2010 Beach et al.
 D618,746 S 6/2010 Jertson et al.
 D618,747 S 6/2010 Schweigert et al.
 D618,753 S 6/2010 Jertson et al.
 D618,754 S 6/2010 Schweigert et al.
 7,744,484 B1 6/2010 Chao
 7,798,203 B2 9/2010 Schweigert et al.
 7,846,041 B2 12/2010 Beach et al.
 D635,626 S 4/2011 Nicolette
 D636,893 S 4/2011 Nicholls et al.
 7,927,229 B2 4/2011 Jertson et al.
 D638,896 S 5/2011 Schweigert et al.
 7,963,861 B2 6/2011 Beach et al.
 8,012,038 B1 9/2011 Beach et al.
 D647,585 S 10/2011 Jertson et al.
 D661,751 S 6/2012 Nicolette et al.
 D661,756 S 6/2012 Nicolette et al.
 8,197,357 B1 6/2012 Rice et al.
 8,202,175 B2 6/2012 Ban
 8,257,196 B1 9/2012 Abbott et al.
 8,257,197 B2 9/2012 Schweiger
 8,262,506 B2 9/2012 Watson et al.
 D673,630 S 1/2013 Schweiger
 D673,632 S 1/2013 Schweigert et al.
 8,371,957 B2 2/2013 Schweigert et al.
 D680,179 S 4/2013 Solheim et al.
 8,414,422 B2 4/2013 Peralta et al.
 8,444,506 B2 5/2013 Watson et al.
 8,485,919 B2 7/2013 Rice et al.
 D691,230 S 10/2013 Chen et al.
 8,562,457 B2 10/2013 Beach et al.
 8,608,587 B2 12/2013 Henrikson et al.
 8,628,431 B2 1/2014 Schweigert et al.
 8,651,975 B2 2/2014 Soracco
 8,663,026 B2 3/2014 Blowers et al.
 8,777,778 B2 7/2014 Solheim et al.
 8,784,232 B2 7/2014 Jertson et al.

(56)

References Cited

U.S. PATENT DOCUMENTS

8,790,196	B2	7/2014	Solheim et al.	
8,808,108	B2	8/2014	Schweiger	
D712,989	S	9/2014	Gillig	
8,826,512	B2	9/2014	Schweiger	
8,858,362	B1	10/2014	Leposky et al.	
8,961,336	B1	2/2015	Parsons et al.	
D724,164	S	3/2015	Schweigert et al.	
8,979,671	B1	3/2015	Demille et al.	
D729,892	S	5/2015	Nicolette et al.	
D733,234	S	6/2015	Nicolette	
9,192,830	B2	11/2015	Parsons et al.	
9,199,140	B1	12/2015	Schweigert et al.	
9,199,143	B1	12/2015	Parsons et al.	
D753,251	S	4/2016	Schweigert et al.	
D756,471	S	5/2016	Nicolette et al.	
9,345,938	B2	5/2016	Parsons et al.	
9,352,197	B2	5/2016	Parsons et al.	
D760,334	S	6/2016	Schweigert et al.	
9,399,158	B2	7/2016	Parsons et al.	
9,399,352	B2	7/2016	Mizutani et al.	
9,427,634	B2	8/2016	Parsons et al.	
9,550,096	B2	1/2017	Parsons et al.	
9,630,070	B2	4/2017	Parsons et al.	
9,833,667	B1	12/2017	Parsons et al.	
9,981,160	B2*	5/2018	Parsons	A63B 53/0466
10,420,989	B2	9/2019	Parsons et al.	
2003/0027662	A1	2/2003	Werner et al.	
2003/0104878	A1	6/2003	Yabu	
2004/0033646	A1	2/2004	Tang et al.	
2004/0087388	A1	5/2004	Beach et al.	
2005/0101408	A1	5/2005	Sanchez et al.	
2005/0192116	A1	9/2005	Imamoto	
2006/0105856	A1	5/2006	Lo	
2006/0111200	A1	5/2006	Poynor	
2007/0004527	A1	1/2007	Helmstetter	
2007/0049400	A1*	3/2007	Imamoto	A63B 53/0466 473/329
2007/0129161	A1	6/2007	Matsunaga et al.	

2007/0238551	A1	10/2007	Yokota
2007/0293344	A1	12/2007	Davis
2008/0004133	A1	1/2008	Schweiger
2008/0015049	A1	1/2008	Imamoto
2008/0188322	A1	8/2008	Anderson et al.
2008/0261715	A1	10/2008	Carter et al.
2009/0029795	A1	1/2009	Schweigert et al.
2009/0069113	A1	3/2009	Nakano
2010/0144461	A1	6/2010	Ban
2010/0167837	A1	7/2010	Ban
2010/0331102	A1	12/2010	Golden et al.
2011/0143858	A1	6/2011	Peralta et al.
2011/0152001	A1	6/2011	Hirano
2012/0142445	A1	6/2012	Burnett et al.
2012/0202615	A1	8/2012	Beach et al.
2012/0220387	A1	8/2012	Beach et al.
2013/0210542	A1	8/2013	Harbert et al.
2013/0303304	A1	11/2013	Sato
2013/0318772	A1	12/2013	Wahl et al.
2013/0324281	A1	12/2013	Boyd et al.
2014/0235369	A1	8/2014	Willett et al.

OTHER PUBLICATIONS

PCT/US16/17474: International Search Report and Written Opinion dated May 12, 2016 (8 Pages).

PCT/US2015/016666: International Search Report and Written Opinion dated May 14, 2015 (8 Pages).

PCT/US2015/042282: International Search Report and Written Opinion dated Oct. 13, 2015 (12 Pages).

PCT/US2017/013513: International Search Report and Written Opinion dated Mar. 17, 2017 (8 Pages).

U.S. Appl. No. 29/512,313, Nicolette, "Golf Club Head," filed Dec. 18, 2018.

Wall, Jonathan, "Details: Phil'S Prototype Mack Daddy PM-Grind Wedge," (<http://www.pgatour.com/equipmentreport/2015/01/21/callaway-wedge.html>), www.pgstour.com, PGA Tour, Inc., Published Jan. 21, 2015.

* cited by examiner

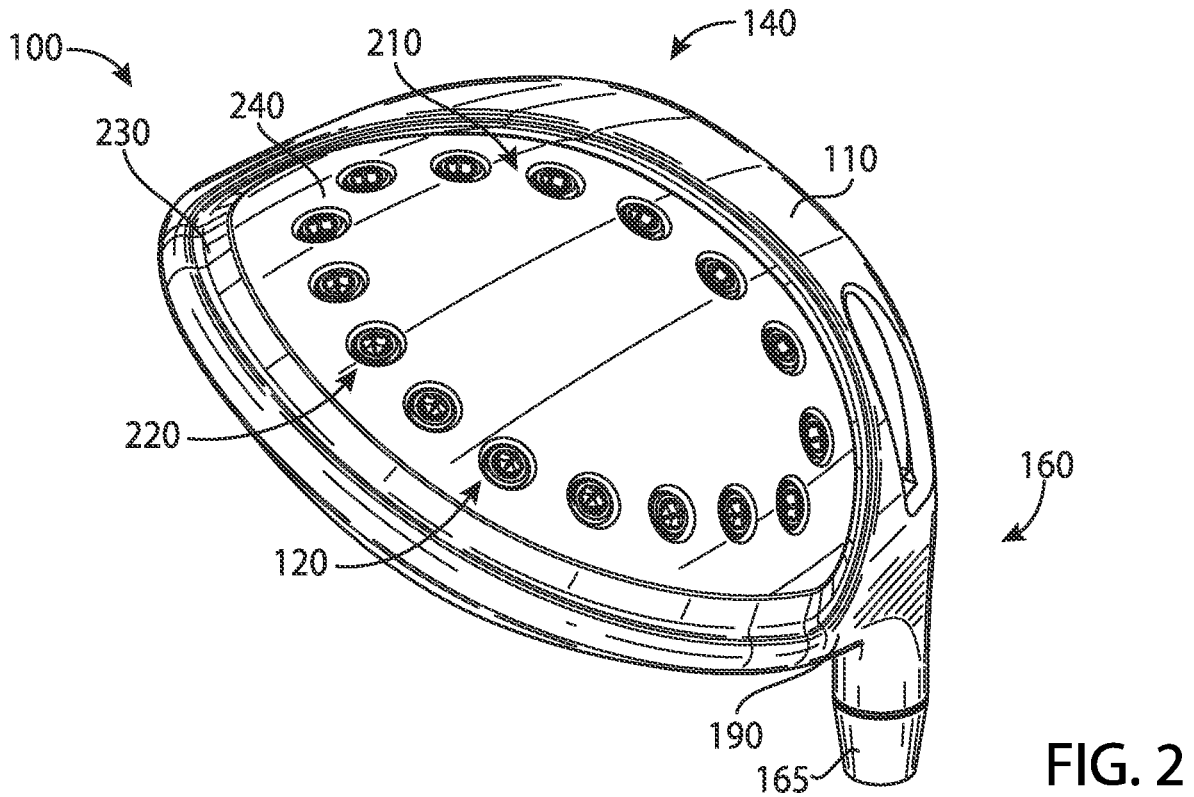
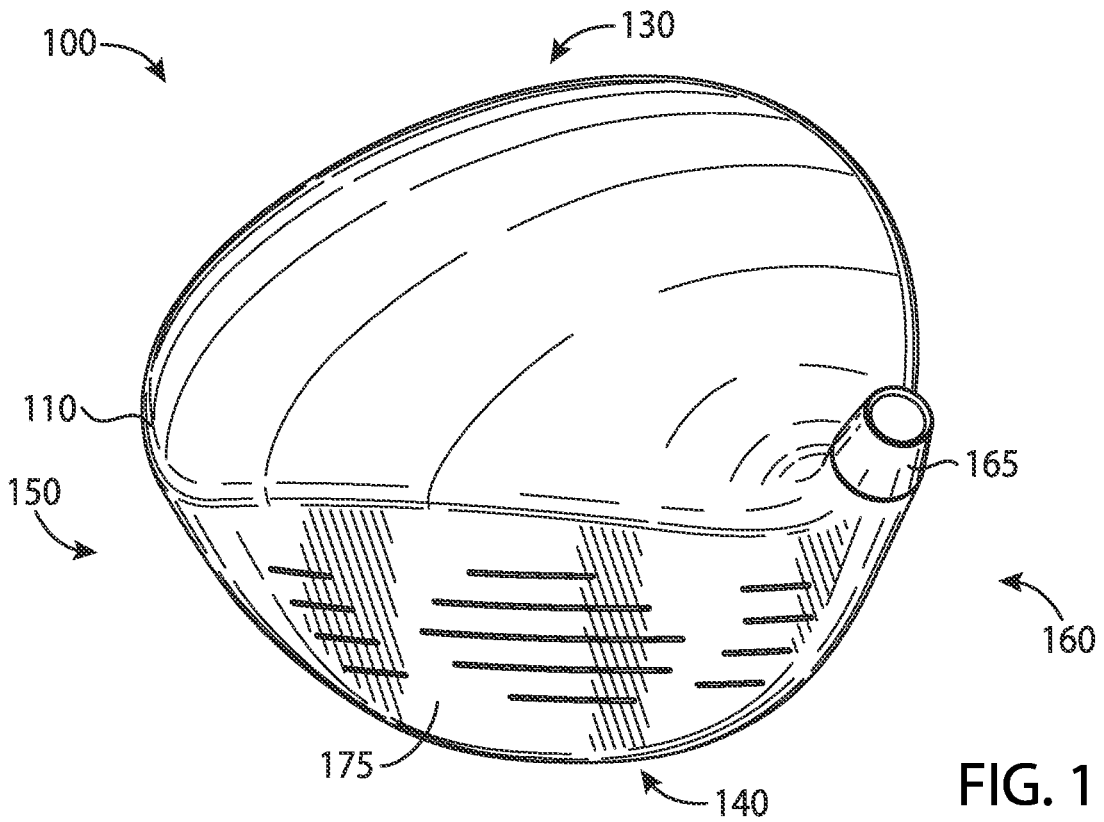

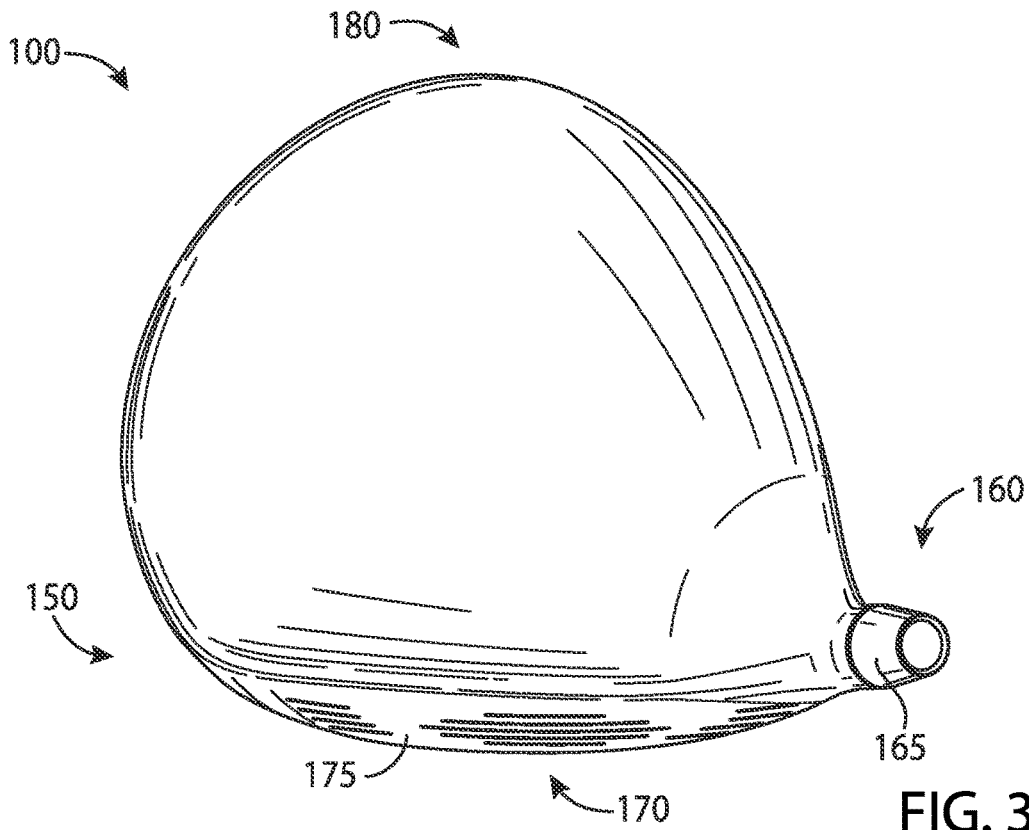

FIG. 3

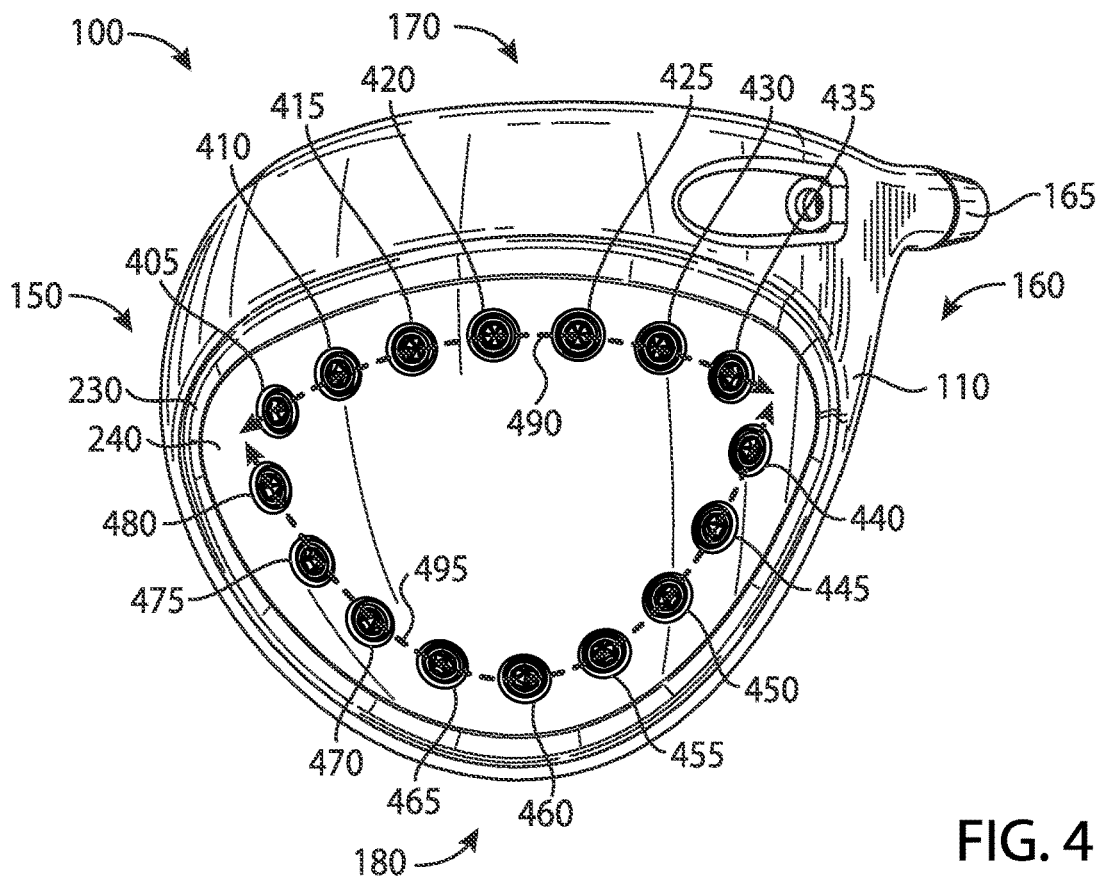

FIG. 4

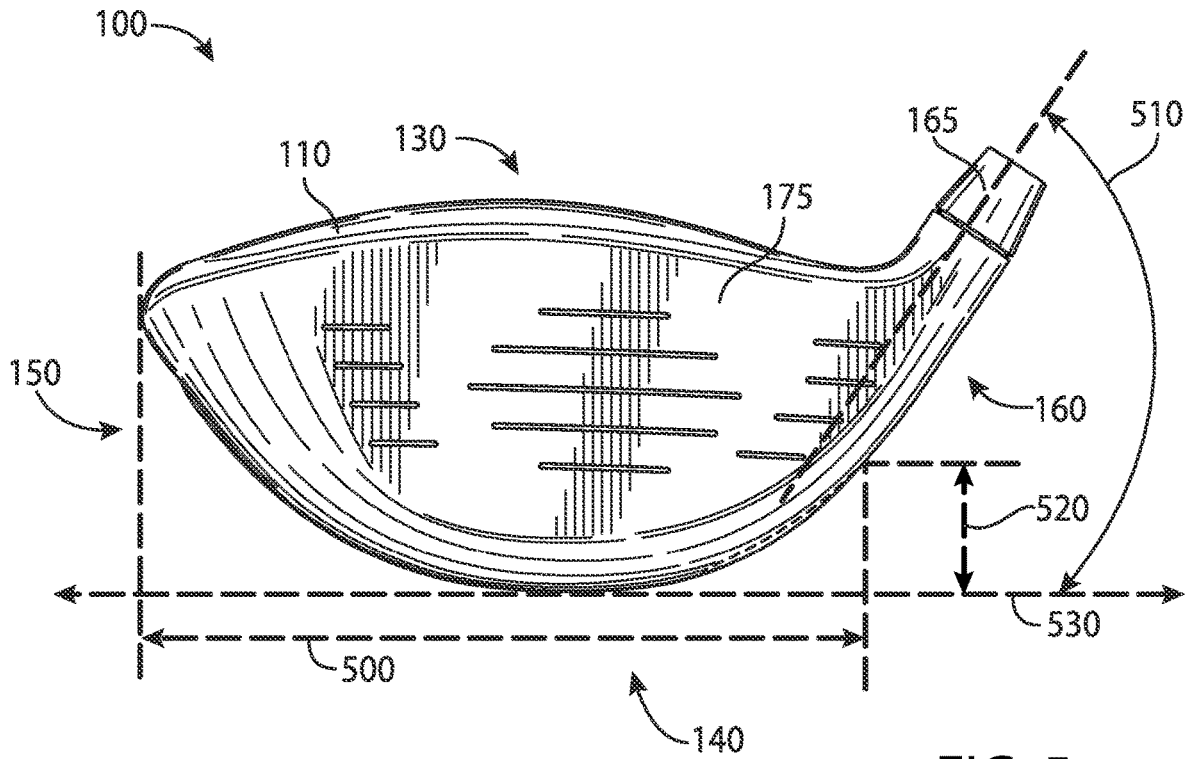

FIG. 5

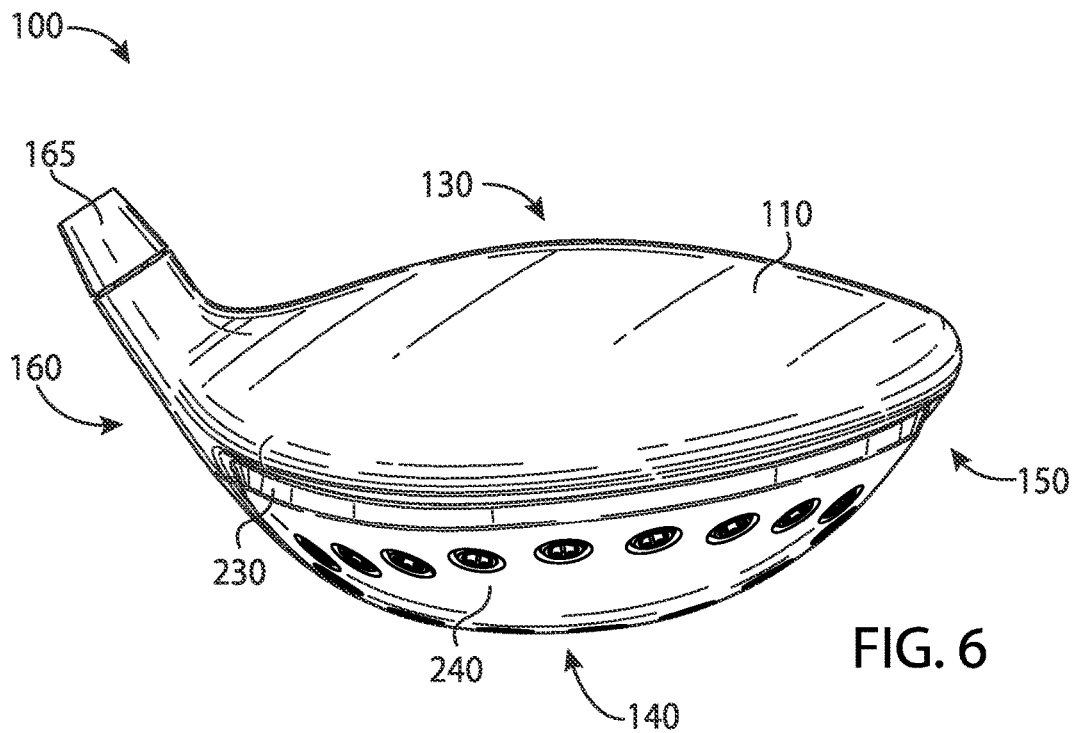

FIG. 6

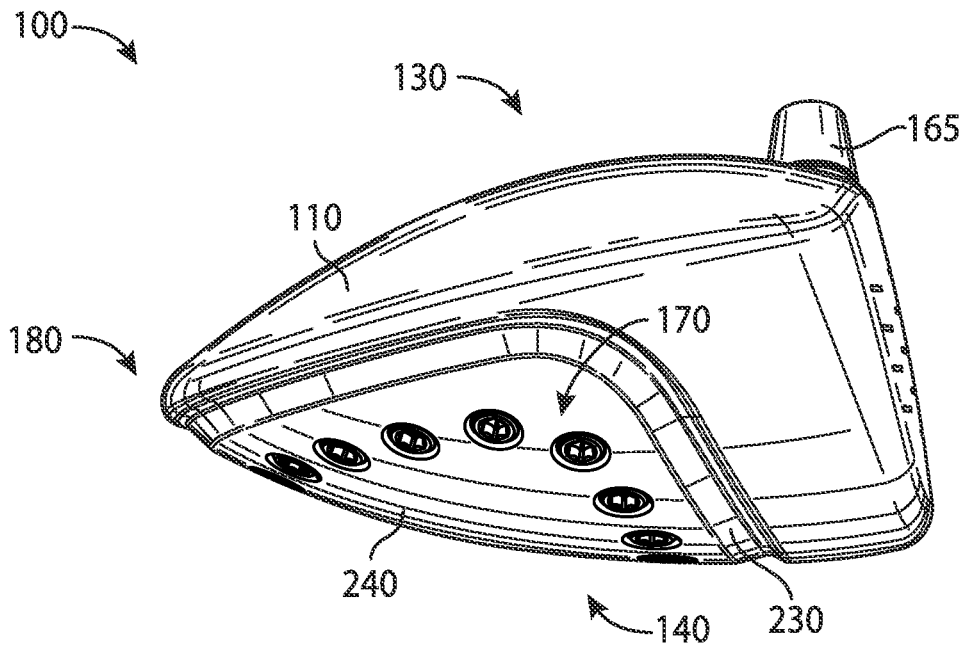

FIG. 7

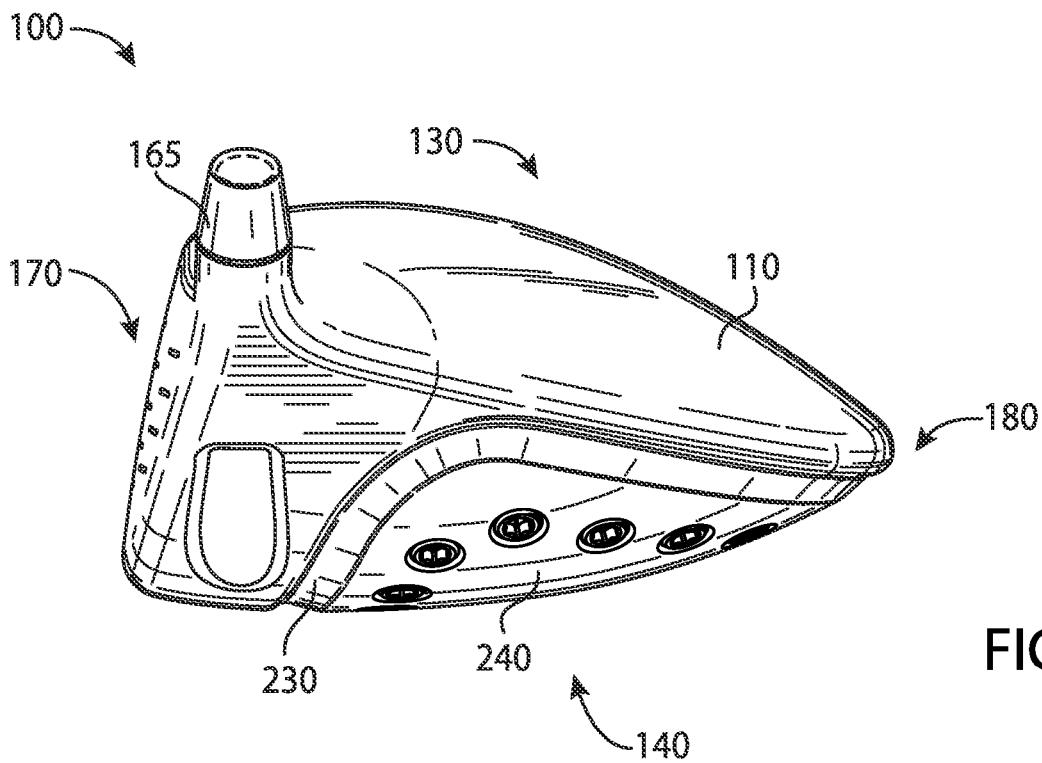
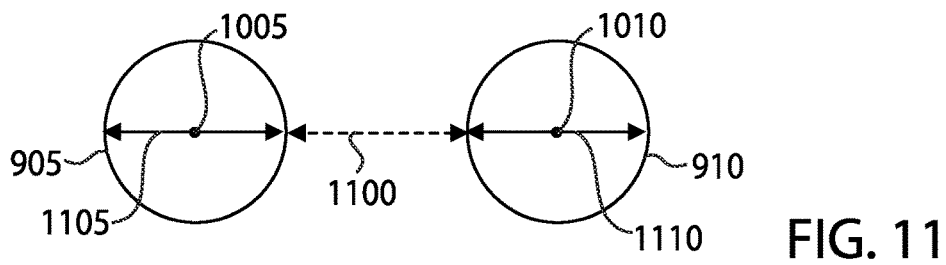
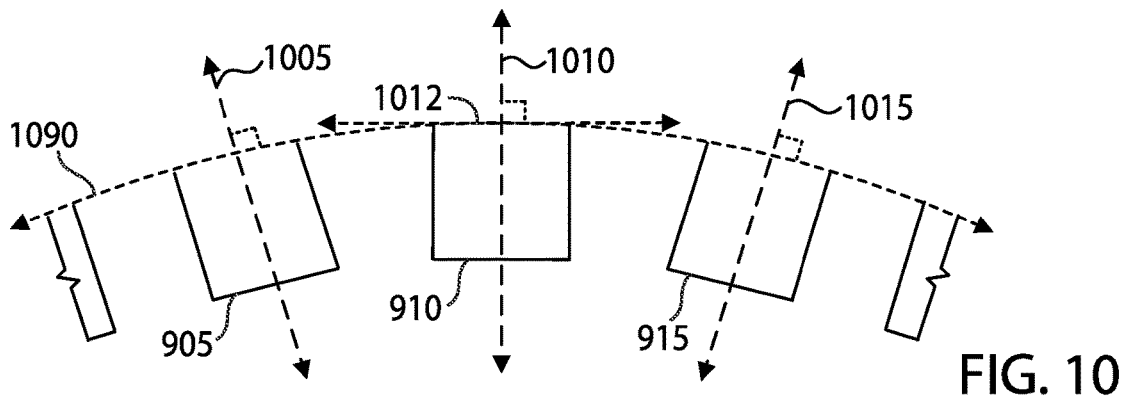
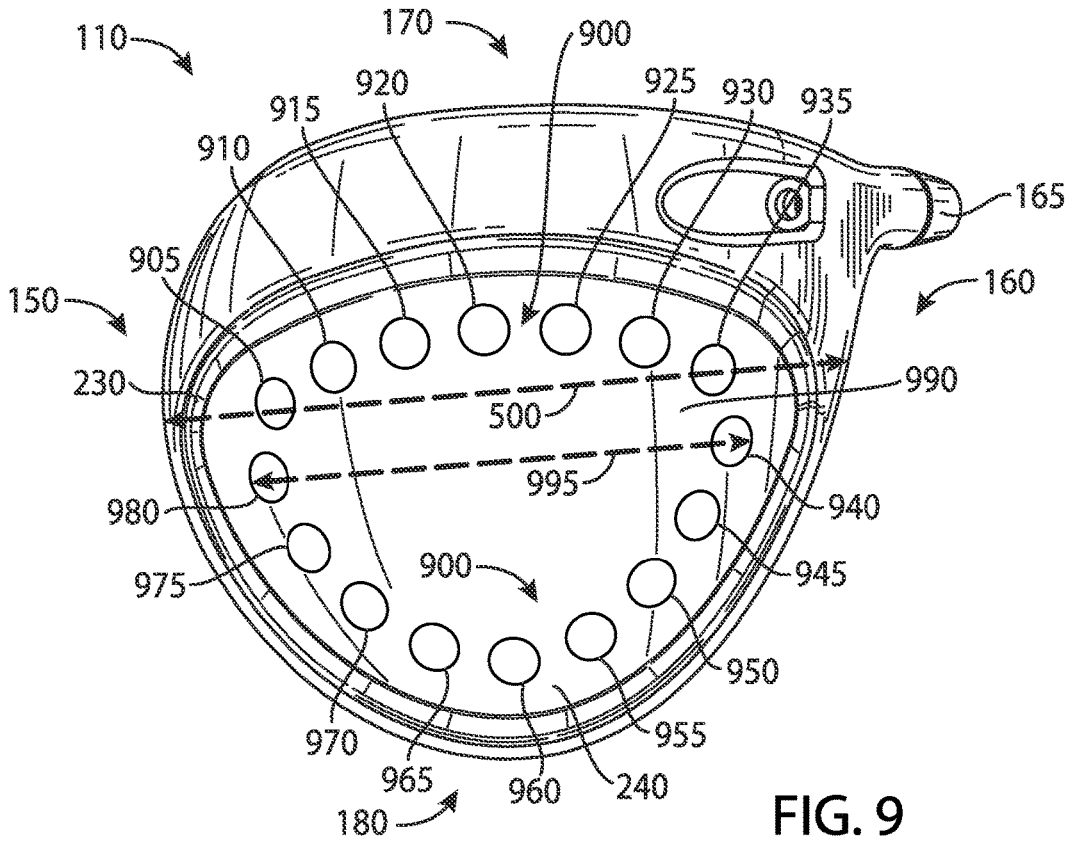

FIG. 8



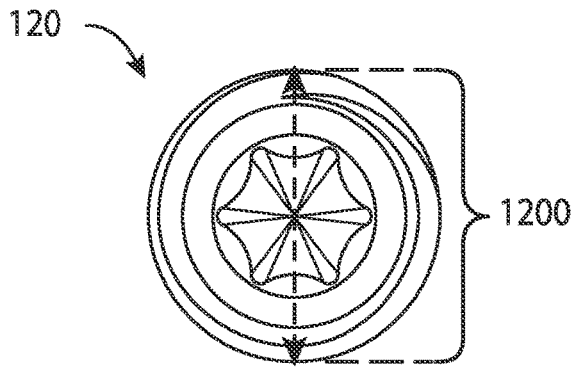

FIG. 12

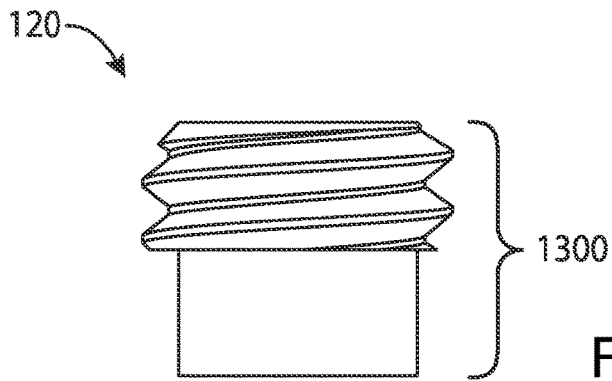

FIG. 13

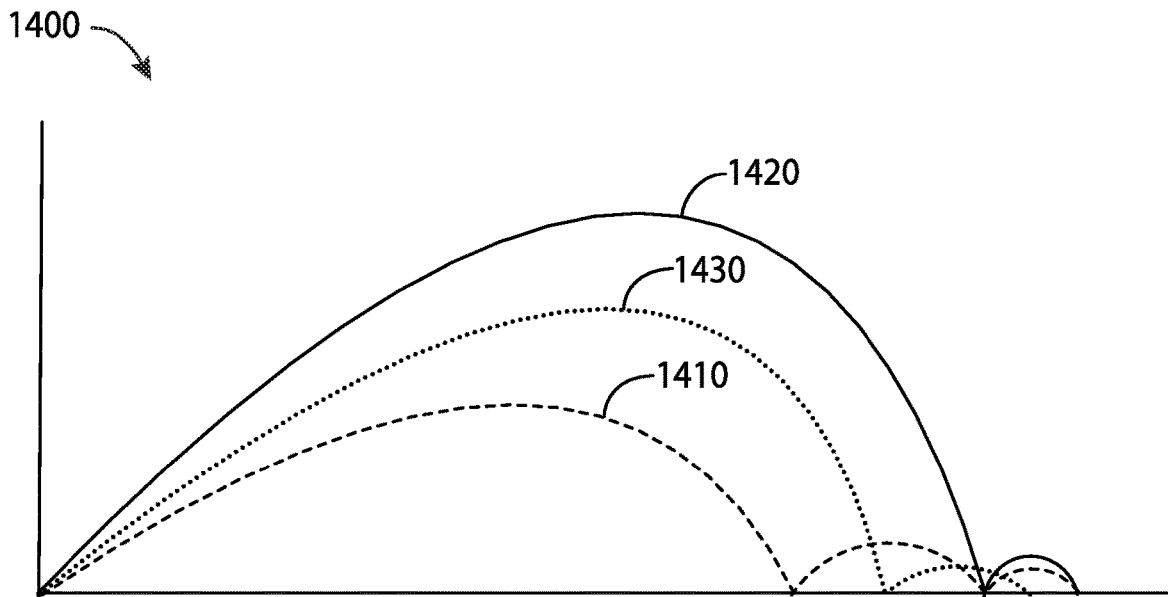

FIG. 14

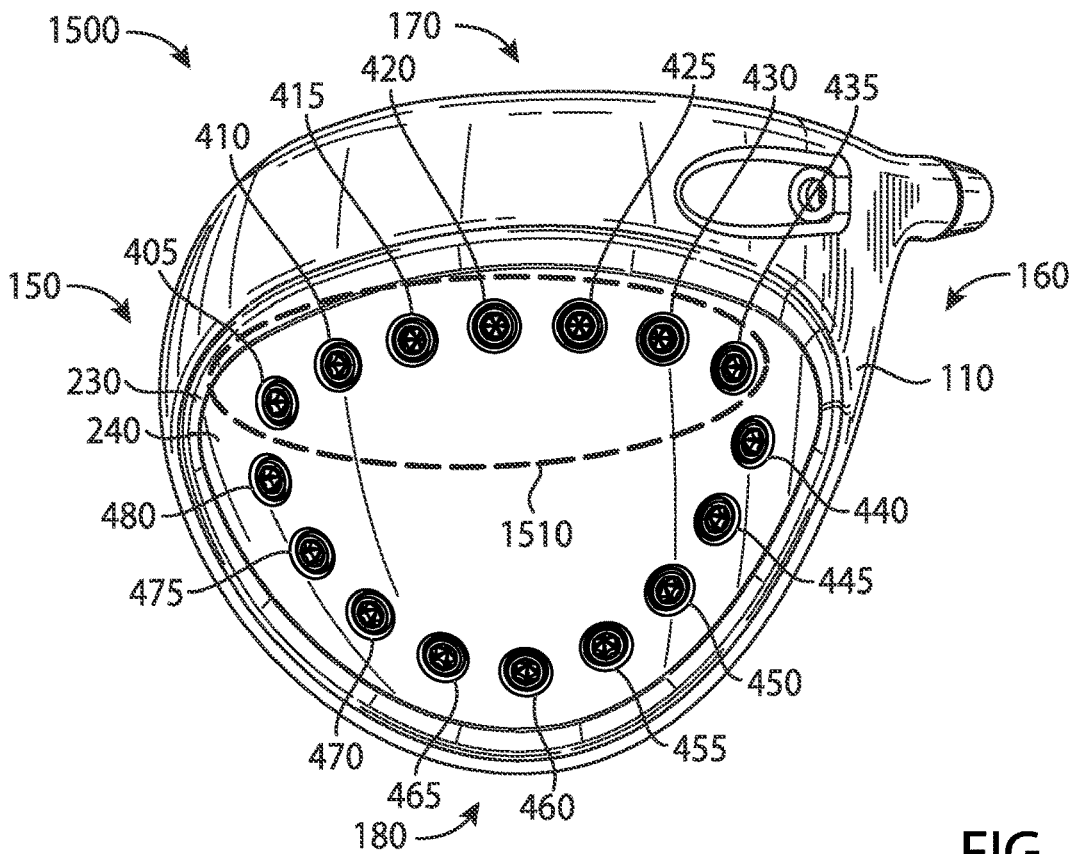

FIG. 15

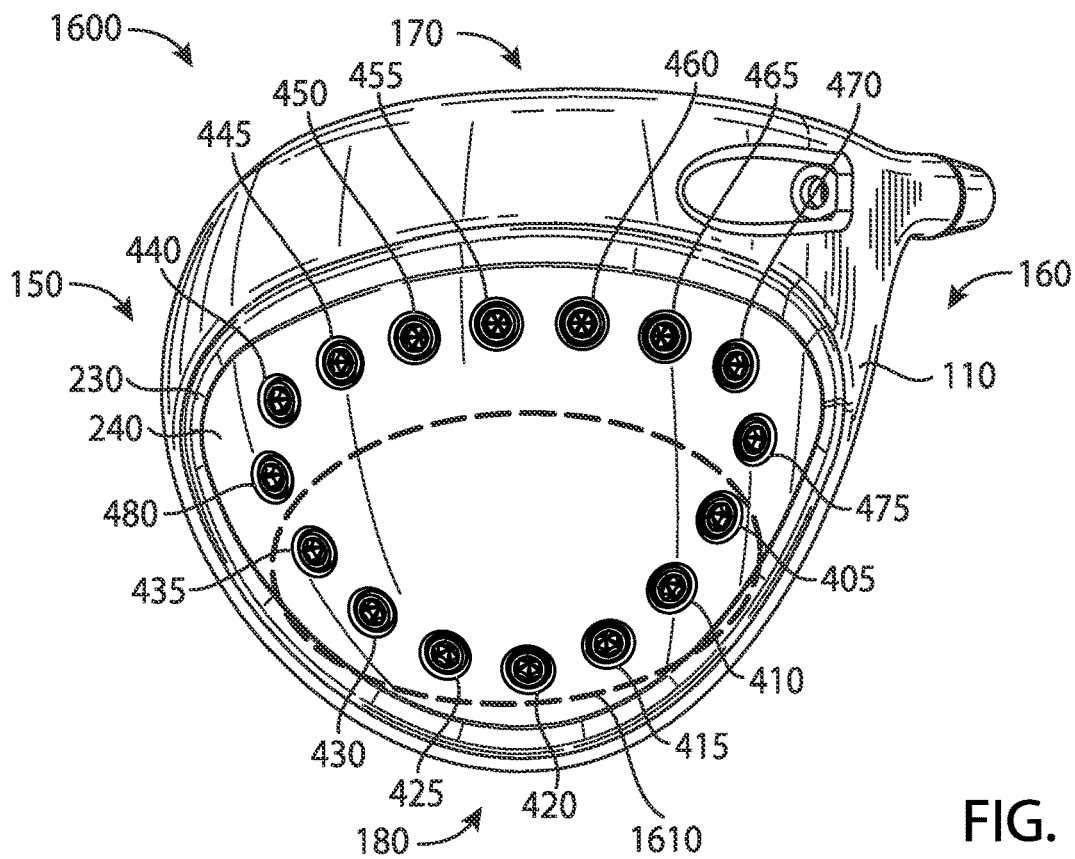

FIG. 16

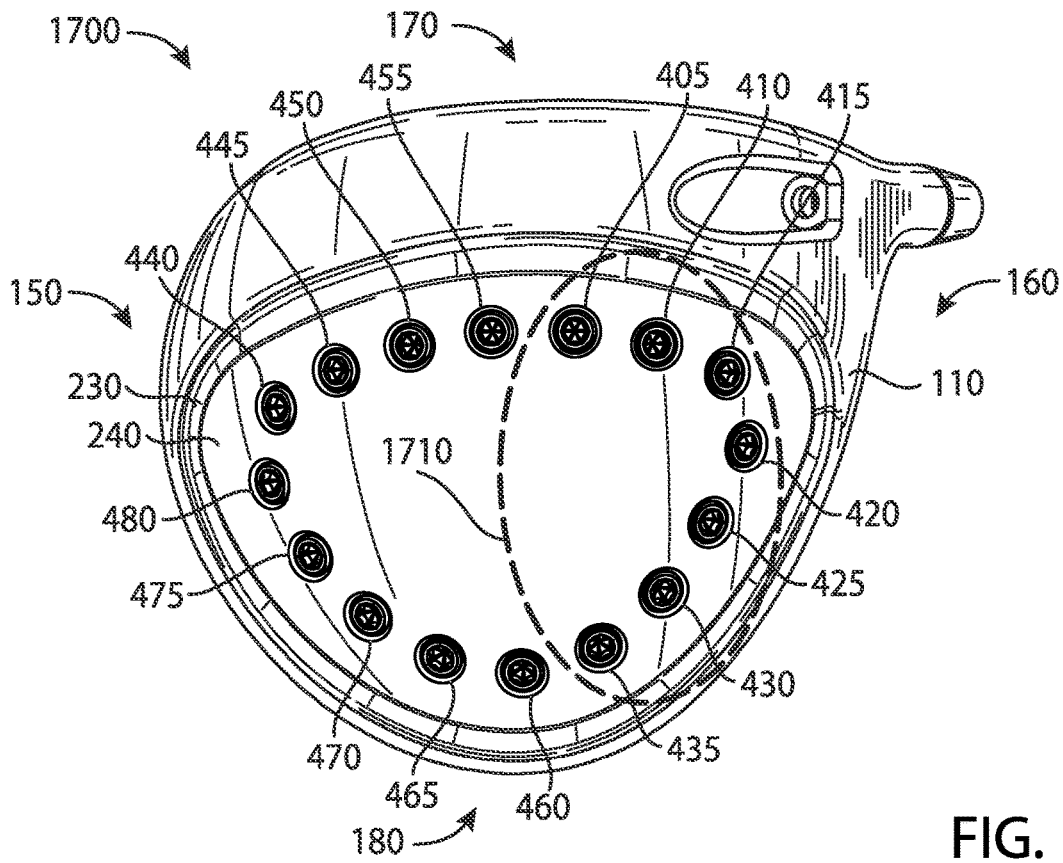

FIG. 17

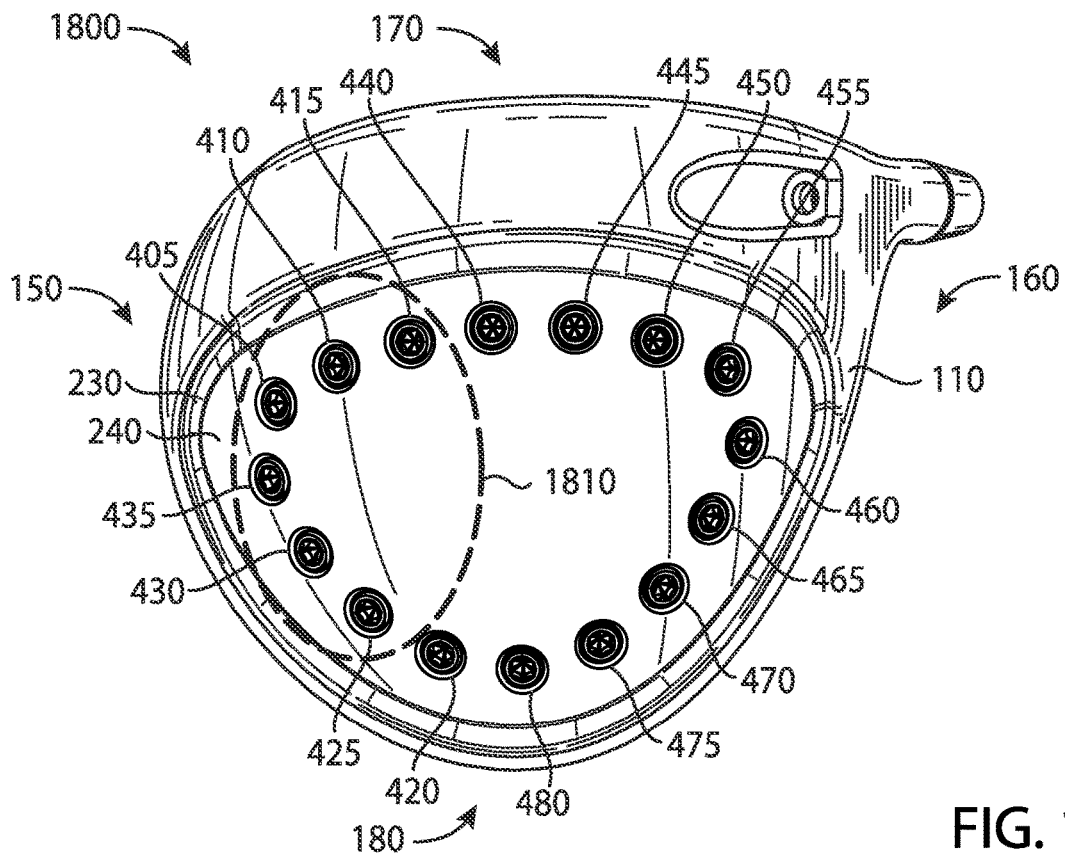

FIG. 18

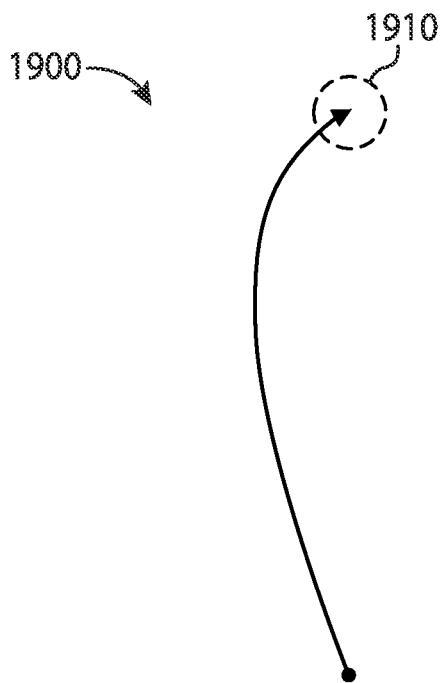

FIG. 19

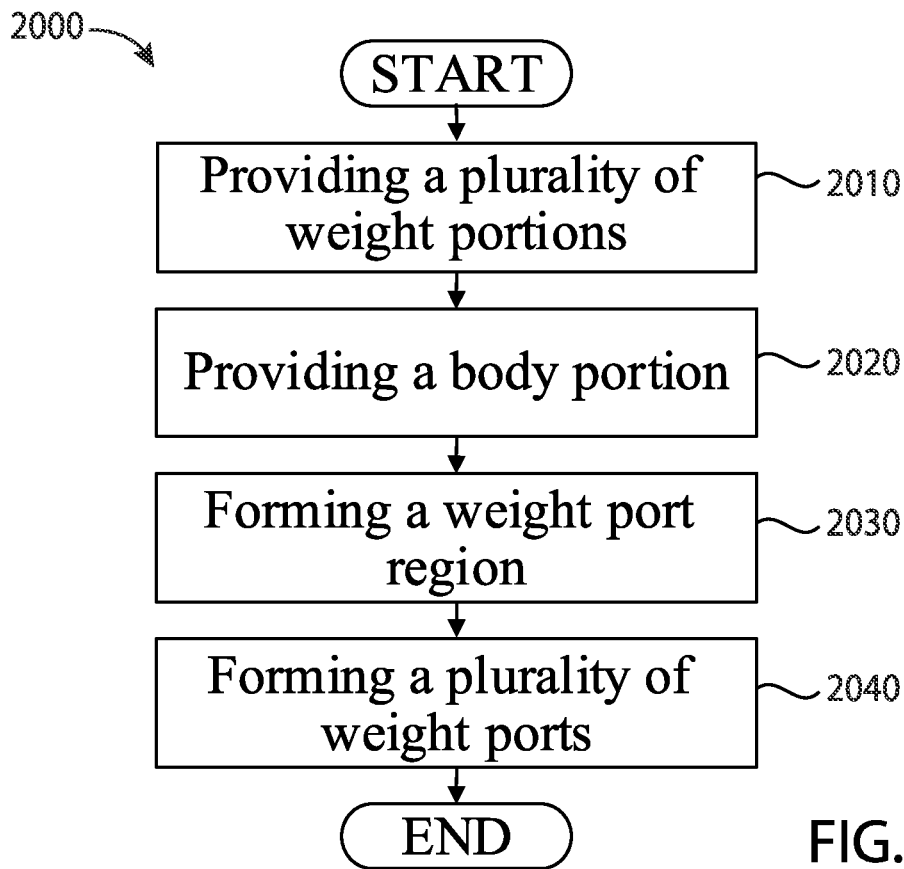

FIG. 20

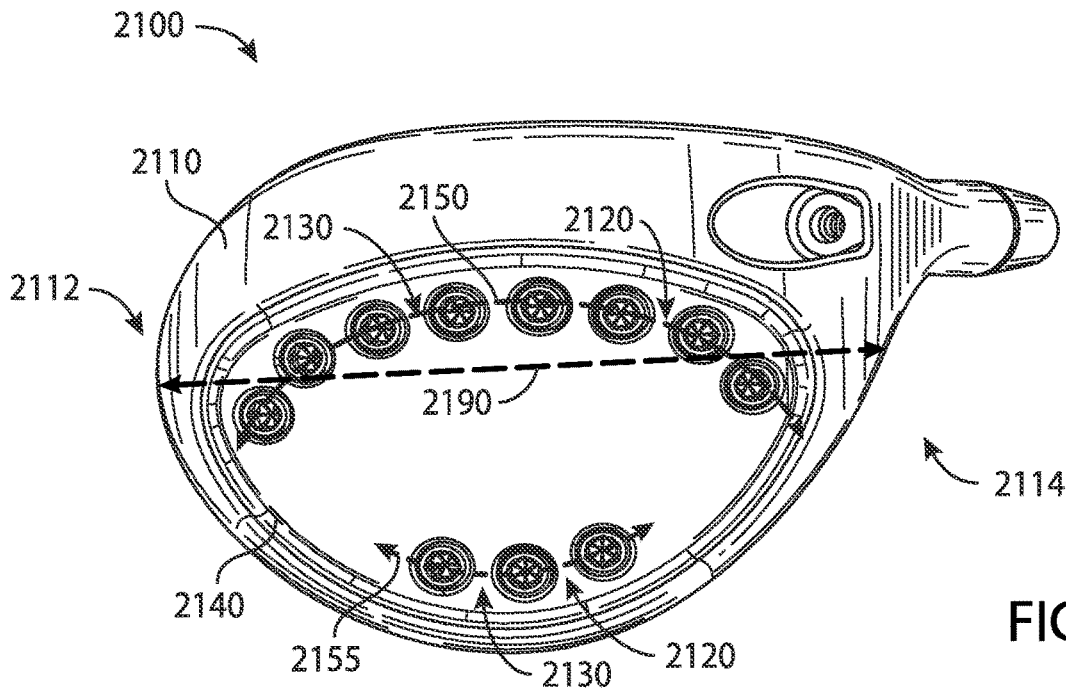

FIG. 21

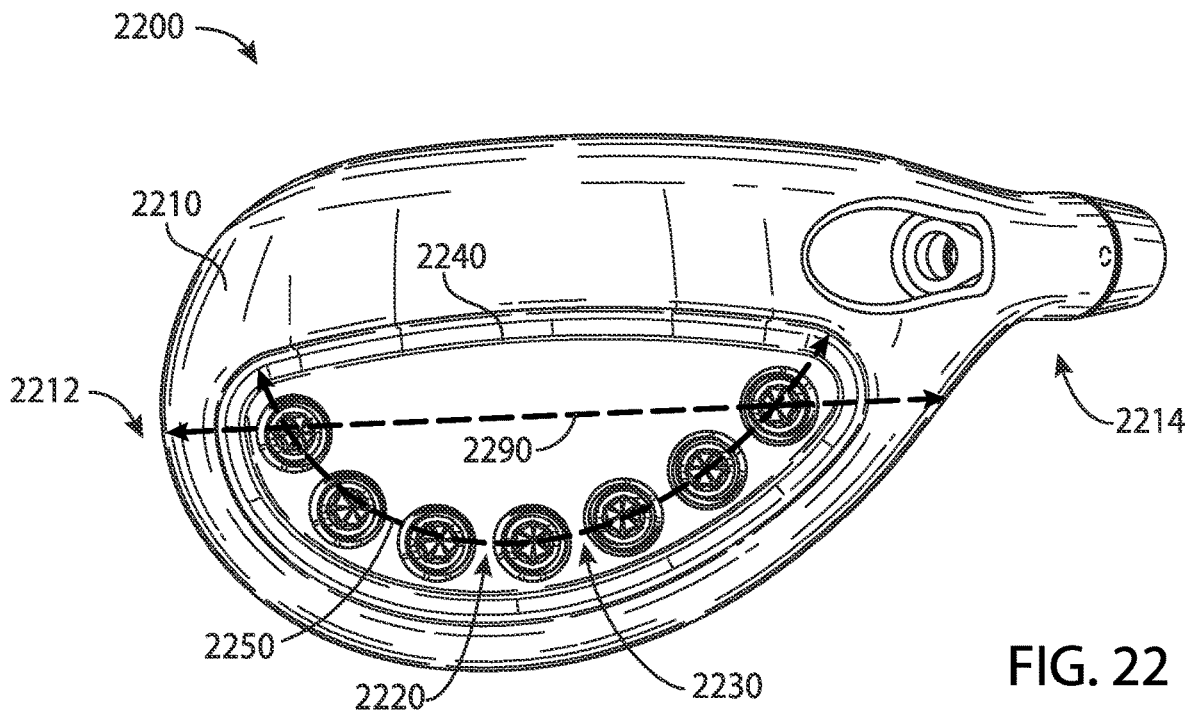

FIG. 22

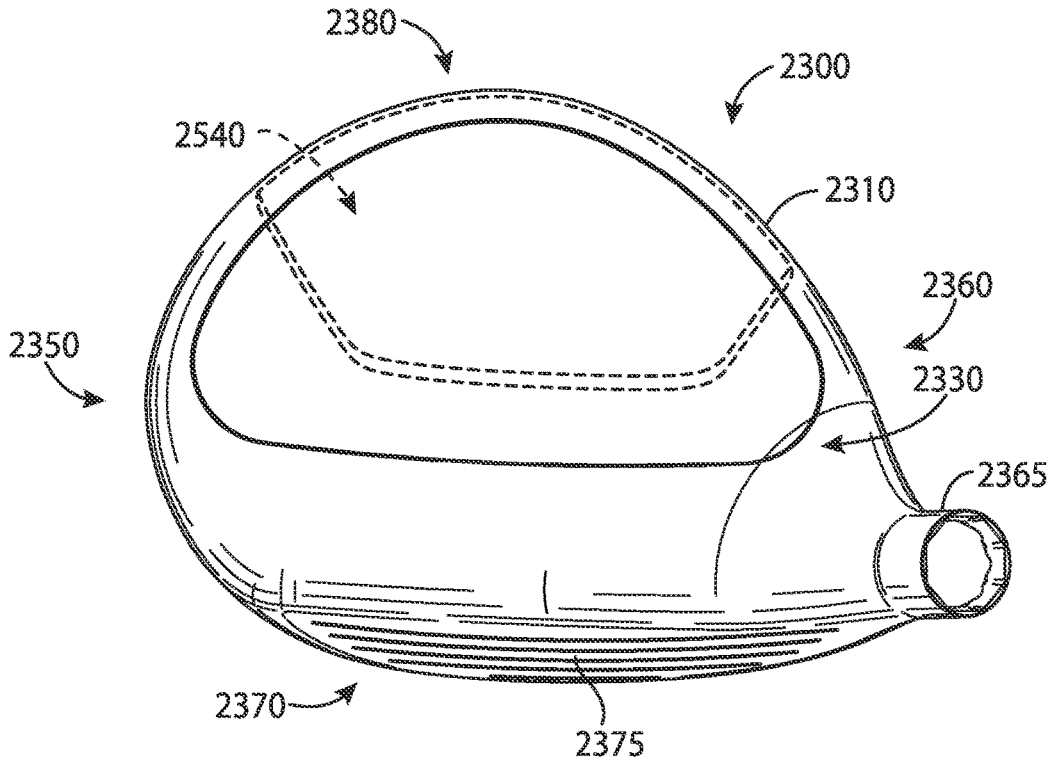

FIG. 23

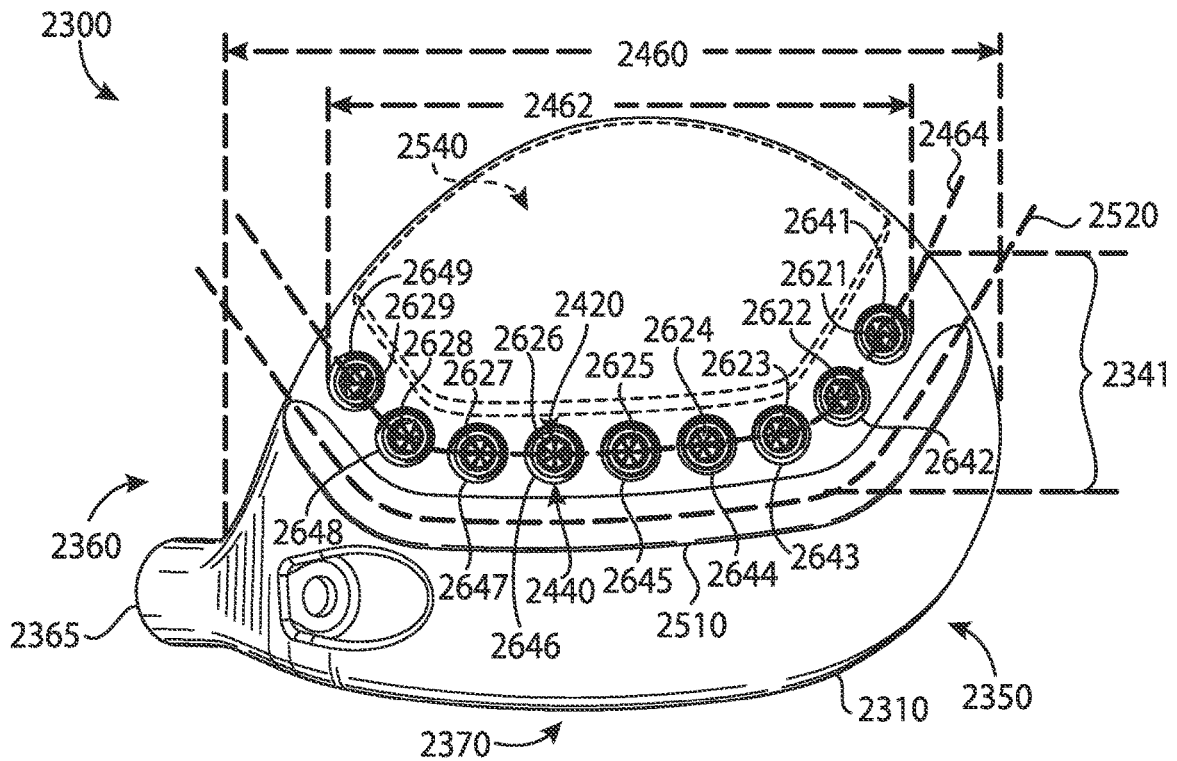
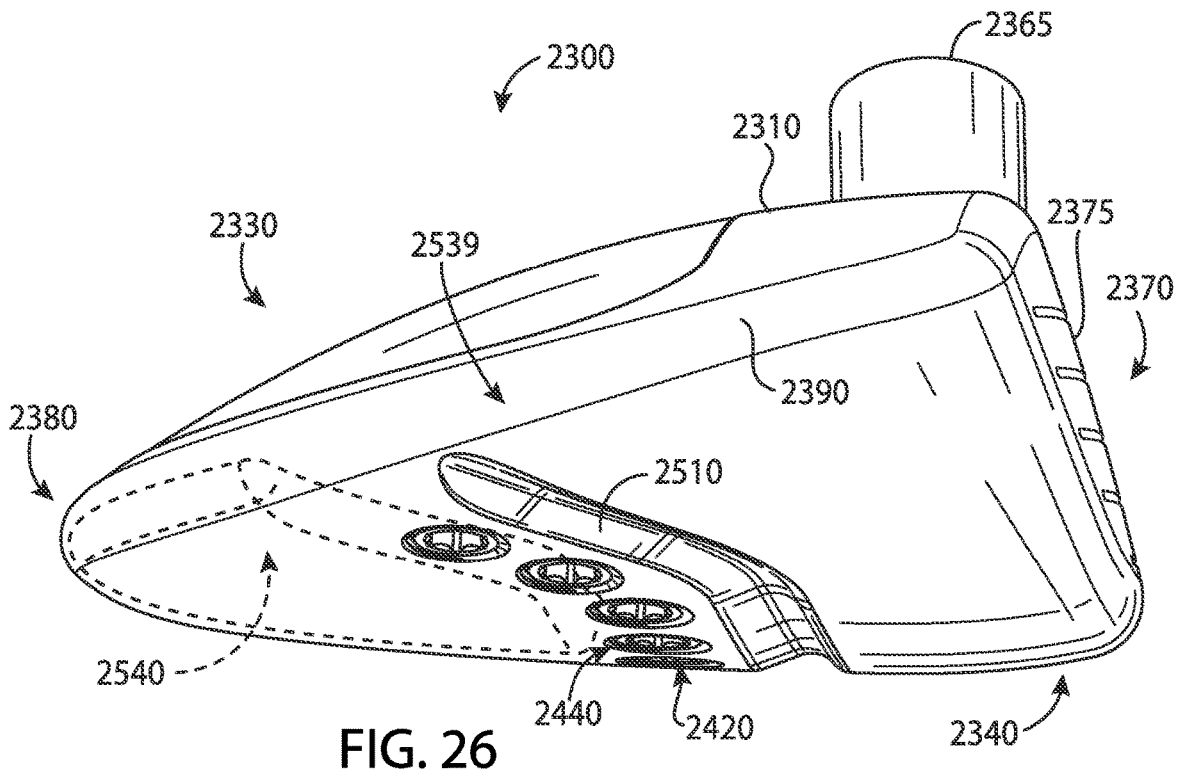
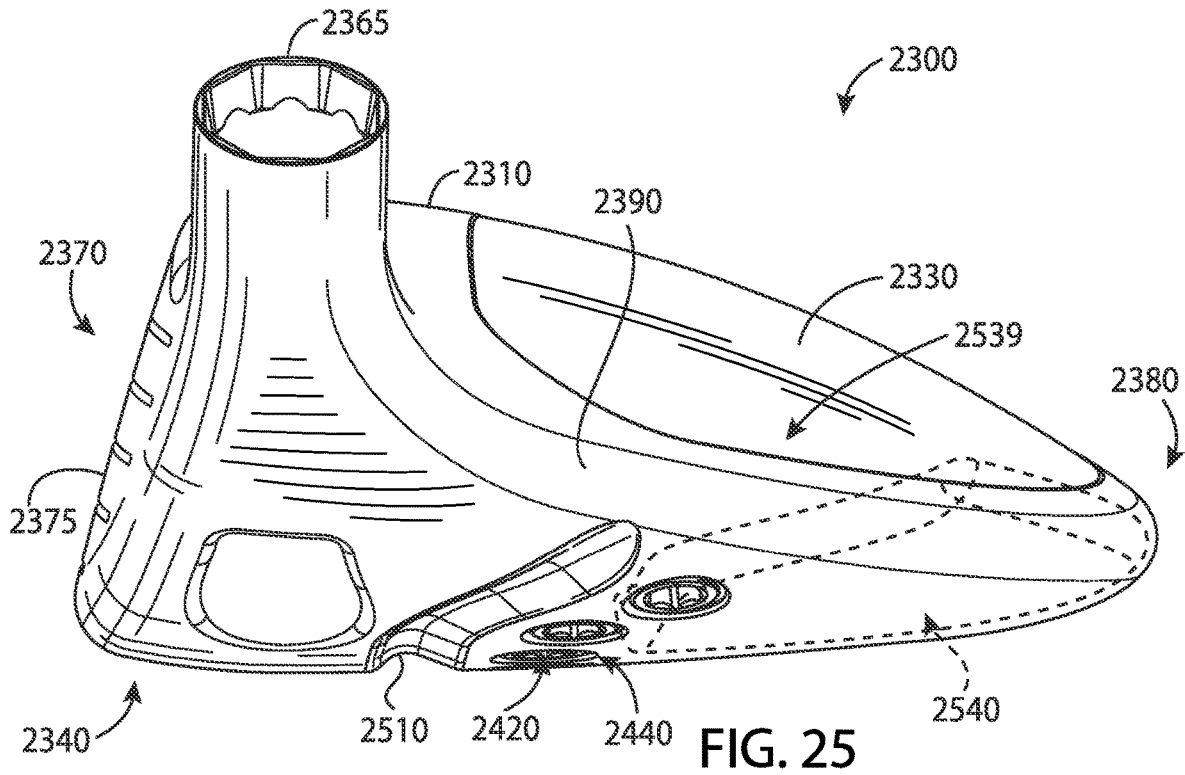

FIG. 24



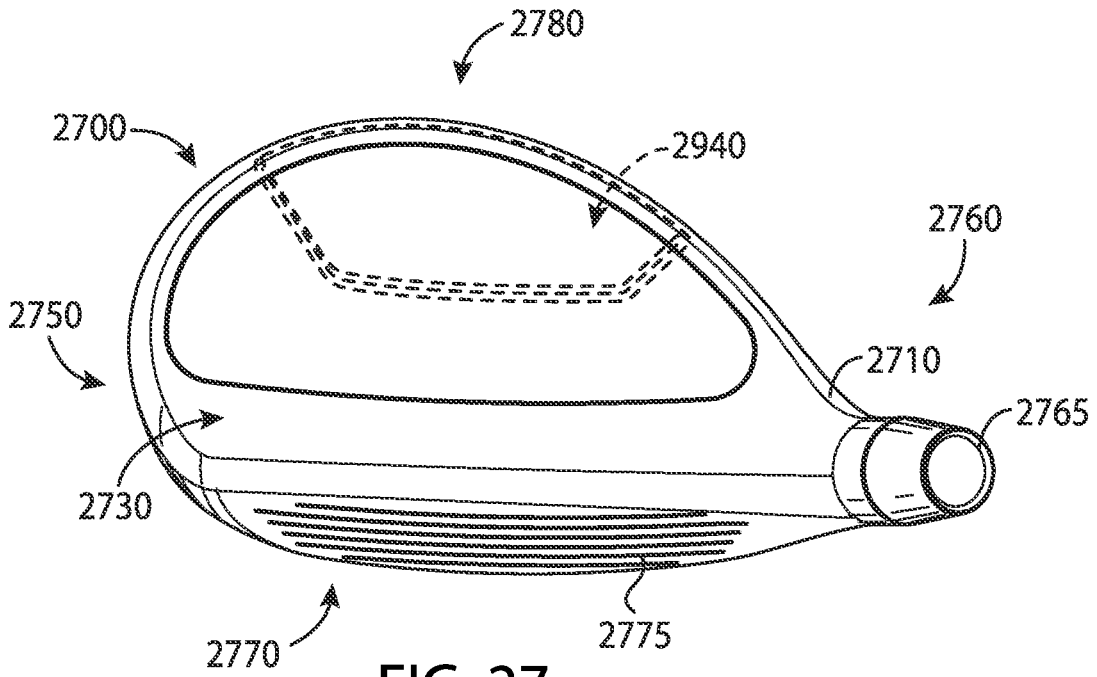

FIG. 27

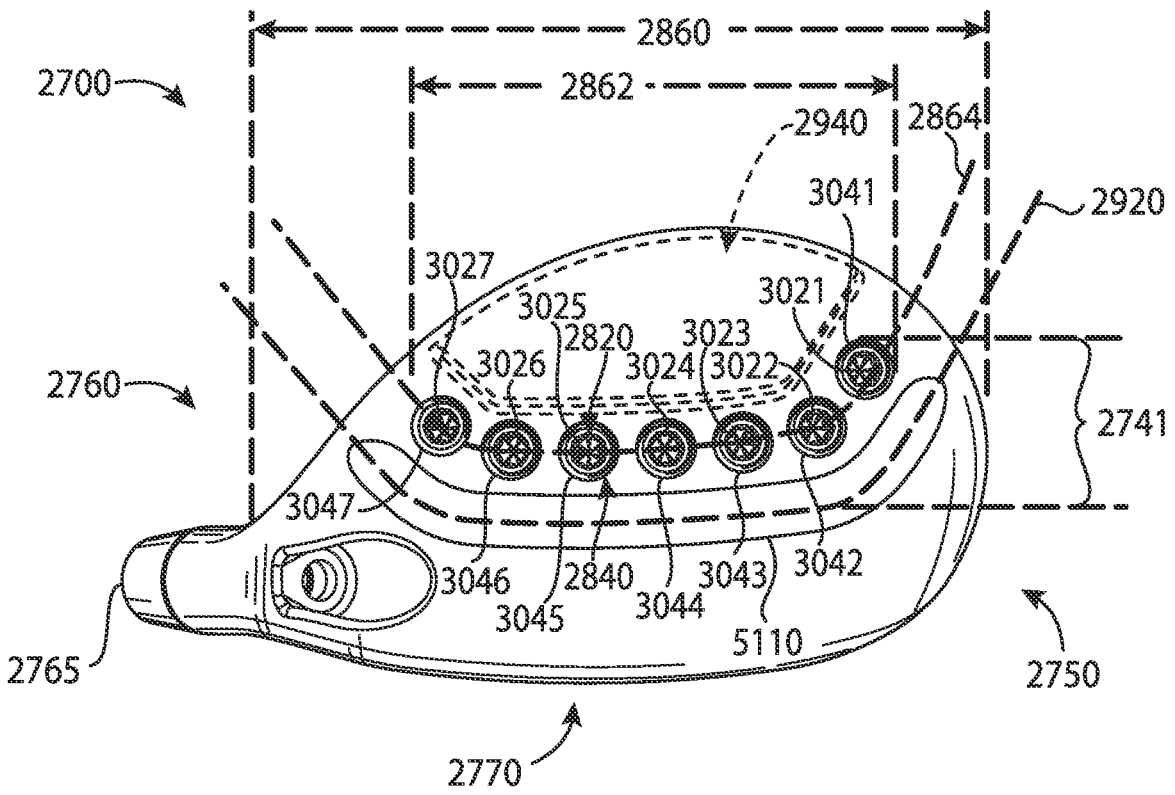

FIG. 28

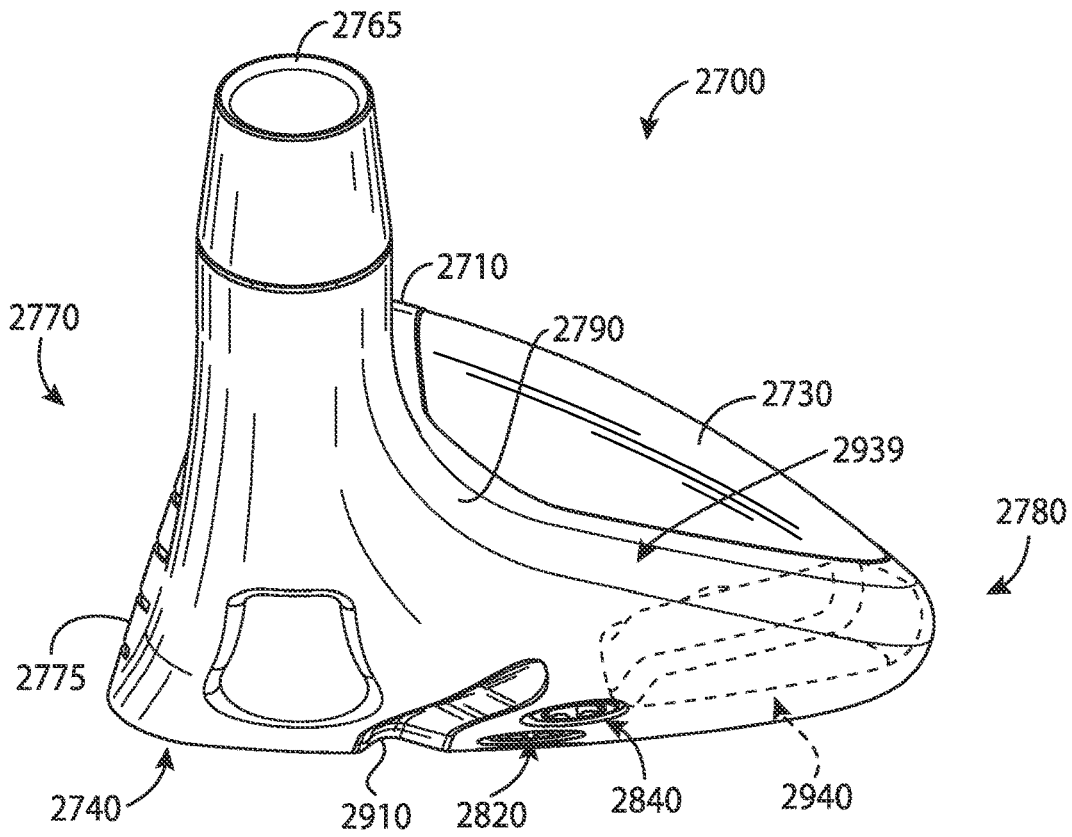

FIG. 29

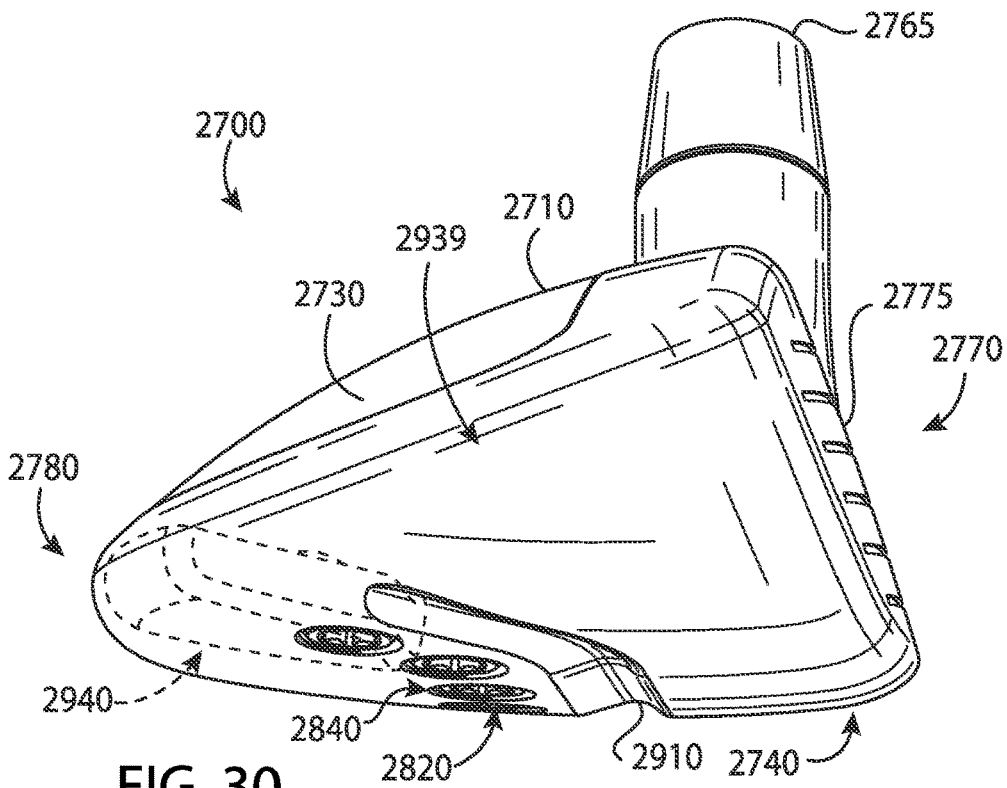

FIG. 30

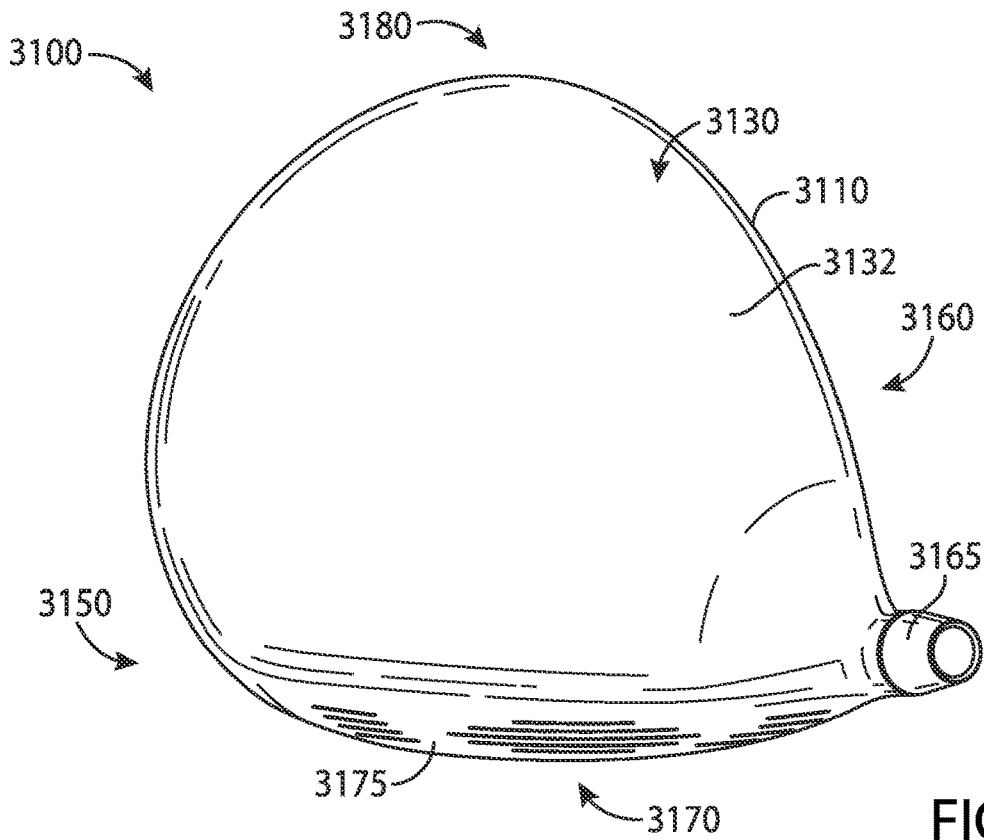

FIG. 31

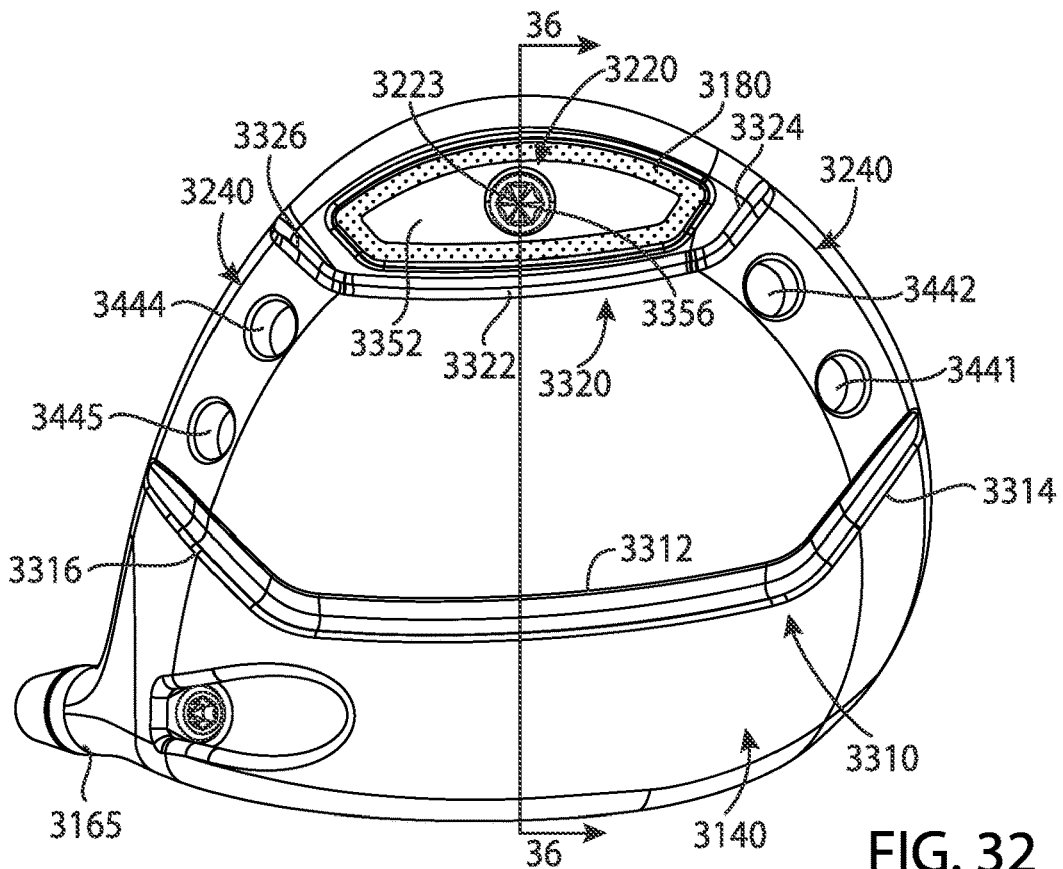
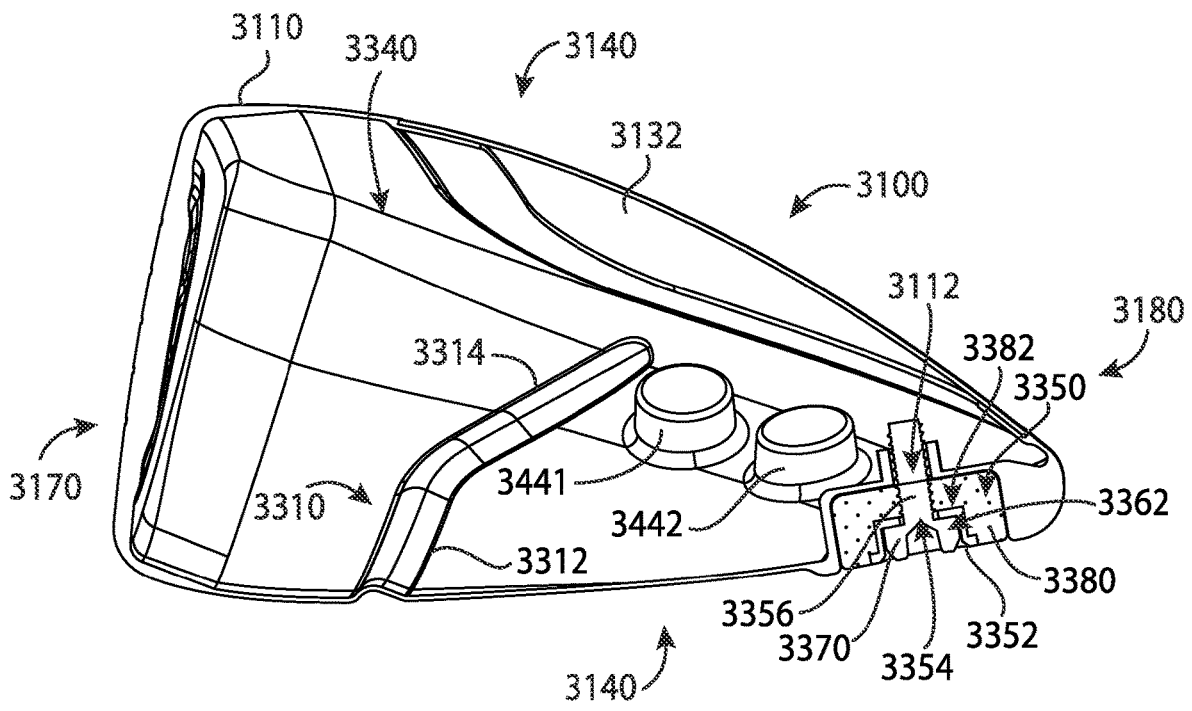
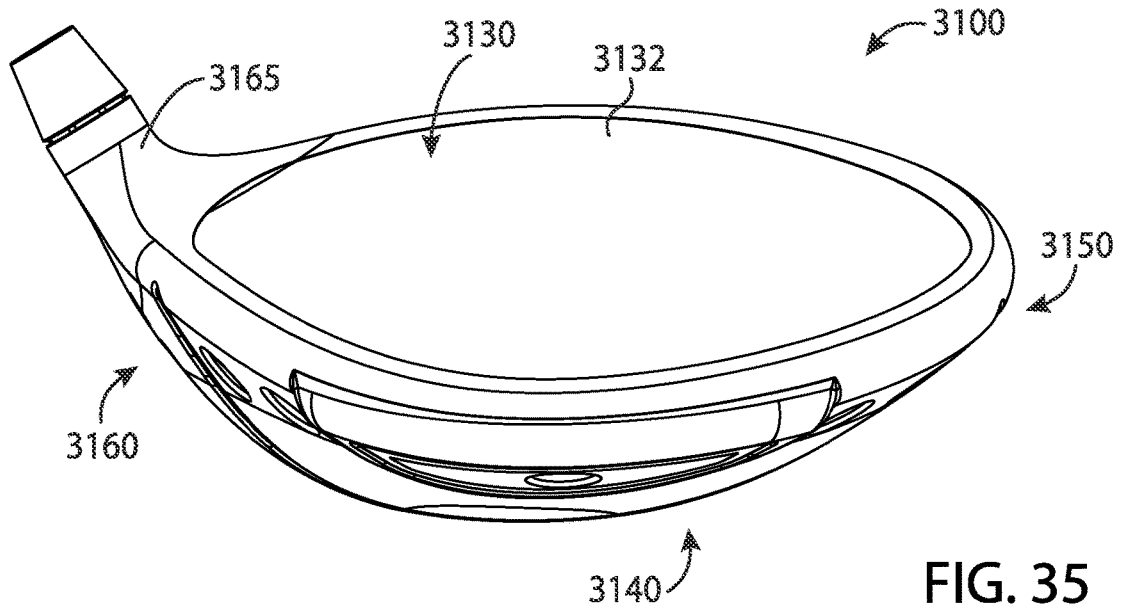

FIG. 32



**GOLF CLUB HEADS AND METHODS TO
MANUFACTURE GOLF CLUB HEADS**

CROSS REFERENCE

This application is a continuation-in-part of application Ser. No. 16/815,164, filed Mar. 11, 2020, which is a continuation of application Ser. No. 16/375,553, filed Apr. 4, 2019, now U.S. Pat. No. 10,695,623, which is a continuation of application Ser. No. 15/967,117, filed Apr. 30, 2018, now U.S. Pat. No. 10,293,221, which is a continuation application Ser. No. 15/457,618, filed Mar. 13, 2017, now U.S. Pat. No. 9,987,526, which is a continuation of application Ser. No. 15/163,393, filed May 24, 2016, now U.S. Pat. No. 9,662,547, which is a continuation of application Ser. No. 14/667,541, filed Mar. 24, 2015, now U.S. Pat. No. 9,352,197, which is a continuation-in-part of application Ser. No. 14/615,606, filed Feb. 6, 2015, now U.S. Pat. No. 9,199,140, which claims the benefit of U.S. Provisional Application No. 62/042,155, filed Aug. 26, 2014, U.S. Provisional Application No. 62/048,693, filed Sep. 10, 2014, U.S. Provisional Application No. 62/101,543, filed Jan. 9, 2015, U.S. Provisional Application No. 62/105,123, filed Jan. 19, 2015, and U.S. Provisional Application No. 62/109,510, filed Jan. 29, 2015.

This application is a continuation-in-part of application Ser. No. 16/820,366, filed Mar. 16, 2020, which is a continuation of application Ser. No. 16/418,691, filed May 21, 2019, now U.S. Pat. No. 10,653,928, which is a continuation of application Ser. No. 15/803,157, filed Nov. 3, 2017, now U.S. Pat. No. 10,335,645, which is a continuation of application Ser. No. 15/290,859, filed Oct. 11, 2016, now U.S. Pat. No. 9,814,945, which is a continuation of application Ser. No. 15/040,892, filed Feb. 10, 2016, now U.S. Pat. No. 9,550,096, which claims the benefit of U.S. Provisional Application No. 62/115,024, filed Feb. 11, 2015, U.S. Provisional Application No. 62/120,760, filed Feb. 25, 2015, U.S. Provisional Application No. 62/138,918, filed Mar. 26, 2015, U.S. Provisional Application No. 62/184,757, filed Jun. 25, 2015, U.S. Provisional Application No. 62/194,135, filed Jul. 17, 2015, and U.S. Provisional Application No. 62/195,211, filed Jul. 21, 2015.

U.S. application Ser. No. 16/820,366, filed Mar. 16, 2020, is a continuation-in-part of application Ser. No. 16/372,009, filed Apr. 1, 2019, now U.S. Pat. No. 10,821,334, which is a continuation of application Ser. No. 15/875,416, filed Jan. 19, 2018, now U.S. Pat. No. 10,293,220, which is a continuation of application Ser. No. 15/446,842, filed Mar. 1, 2017, now U.S. Pat. No. 9,895,582, which is a continuation of application Ser. No. 15/377,120, filed Dec. 13, 2016, now U.S. Pat. No. 9,802,087, which is a continuation of application Ser. No. 14/939,849, filed Nov. 12, 2015, now U.S. Pat. No. 9,555,295, which is a continuation of application Ser. No. 14/615,606, filed Feb. 6, 2015, now U.S. Pat. No. 9,199,140.

U.S. application Ser. No. 16/820,366, filed Mar. 16, 2020, is a continuation-in-part of application Ser. No. 16/290,610, filed Mar. 1, 2019, now U.S. Pat. No. 10,617,918, which is a continuation of application Ser. No. 15/875,496, filed Jan. 19, 2018, now U.S. Pat. No. 10,252,123, which is a continuation of application Ser. No. 15/457,627, filed Mar. 13, 2017, now U.S. Pat. No. 9,895,583, which is a continuation of application Ser. No. 15/189,806, filed Jun. 22, 2016, now U.S. Pat. No. 9,636,554, which is a continuation of application Ser. No. 14/667,546, filed Mar. 24, 2015, now U.S. Pat. No. 9,399,158, which is a continuation-in-part of application Ser. No. 14/615,606, filed Feb. 6, 2015, now U.S. Pat.

No. 9,199,140, which claims the benefit of U.S. Provisional Application No. 62/042,155, filed Aug. 26, 2014, U.S. Provisional Application No. 62/048,693, filed Sep. 10, 2014, U.S. Provisional Application No. 62/101,543, filed Jan. 9, 2015, U.S. Provisional Application No. 62/105,123, filed Jan. 19, 2015, and U.S. Provisional Application No. 62/109,510, filed Jan. 29, 2015.

U.S. application Ser. No. 16/820,366, filed Mar. 16, 2020, is a continuation-in-part of application Ser. No. 16/375,553, filed Apr. 4, 2019, now U.S. Pat. No. 10,695,623, which is a continuation of application Ser. No. 15/967,117, filed Apr. 30, 2018, now U.S. Pat. No. 10,293,221, which is a continuation application Ser. No. 15/457,618, filed Mar. 13, 2017, now U.S. Pat. No. 9,987,526, which is a continuation of application Ser. No. 15/163,393, filed May 24, 2016, now U.S. Pat. No. 9,662,547, which is a continuation of application Ser. No. 14/667,541, filed Mar. 24, 2015, now U.S. Pat. No. 9,352,197, which is a continuation-in-part of application Ser. No. 14/615,606, filed Feb. 6, 2015, now U.S. Pat. No. 9,199,140, which claims the benefit of U.S. Provisional Application No. 62/042,155, filed Aug. 26, 2014, U.S. Provisional Application No. 62/048,693, filed Sep. 10, 2014, U.S. Provisional Application No. 62/101,543, filed Jan. 9, 2015, U.S. Provisional Application No. 62/105,123, filed Jan. 19, 2015, and U.S. Provisional Application No. 62/109,510, filed Jan. 29, 2015.

This application is a continuation-in-part application Ser. No. 16/713,942, filed Dec. 13, 2019, which is a continuation of application Ser. No. 16/198,128, filed Nov. 21, 2018, now U.S. Pat. No. 10,532,257, which is a continuation of application Ser. No. 15/583,756, filed May 1, 2017, now U.S. Pat. No. 10,143,899, which is a continuation of application Ser. No. 15/271,574, filed Sep. 21, 2016, now U.S. Pat. No. 9,669,270, which claims the benefit of U.S. Provisional Application No. 62/291,793, filed Feb. 5, 2016.

This application is a continuation-in-part of application Ser. No. 16/710,903, filed Dec. 11, 2019, which is a continuation of application Ser. No. 15/994,860, filed May 31, 2018, now U.S. Pat. No. 10,543,407, which is a continuation of application Ser. No. 15/807,201, filed Nov. 8, 2017, now U.S. Pat. No. 10,010,770, which is a continuation of application Ser. No. 15/463,306, filed Mar. 20, 2017, now U.S. Pat. No. 9,821,200, which is a continuation of application Ser. No. 15/249,857, filed Aug. 29, 2016, now U.S. Pat. No. 9,630,070, which claims the benefit of U.S. Provisional Application No. 62/337,184, filed May 16, 2016, and U.S. Provisional Application No. 62/361,988, filed Jul. 13, 2016.

U.S. application Ser. No. 16/710,903, filed Dec. 11, 2019 is a continuation-in-part of application Ser. No. 16/539,397, filed Aug. 13, 2019, now U.S. Pat. No. 10,786,712, which is a continuation of application Ser. No. 16/035,268, filed Jul. 13, 2018, now U.S. Pat. No. 10,420,990, which is a continuation of application Ser. No. 15/725,900, filed Oct. 5, 2017, now U.S. Pat. No. 10,052,532, which is a continuation of application Ser. No. 15/445,253, filed Feb. 28, 2017, now U.S. Pat. No. 9,795,843, which is a continuation of application Ser. No. 15/227,281, filed Aug. 3, 2016, now U.S. Pat. No. 9,782,643, which claims the benefit of U.S. Provisional Application No. 62/281,639, filed Jan. 21, 2016, U.S. Provisional Application No. 62/296,506, filed Feb. 17, 2016, U.S. Provisional Application No. 62/301,756, filed Mar. 1, 2016, and U.S. Provisional Application No. 62/362,491, filed Jul. 14, 2016.

This application is a continuation of application Ser. No. 16/542,548, filed Aug. 16, 2019, which is a continuation of application Ser. No. 15/967,098, filed Apr. 30, 2018, now U.S. Pat. No. 10,420,989, which is a continuation of appli-

cation Ser. No. 15/687,273, filed Aug. 25, 2017, now U.S. Pat. No. 9,981,160, which claims the benefit of U.S. Provisional Application No. 62/380,727, filed Aug. 29, 2016.

U.S. patent application Ser. No. 16/542,548, filed Aug. 16, 2019 is also a continuation-in-part of application Ser. No. 16/222,580, filed Dec. 17, 2018, now U.S. Pat. No. 10,722,764, which is a continuation of application Ser. No. 15/831,148, filed Dec. 4, 2017, now U.S. Pat. No. 10,195,101, which is a continuation of application Ser. No. 15/453,701, filed Mar. 8, 2017, now U.S. Pat. No. 9,833,667, which claims the benefit of U.S. Provisional Application No. 62/356,539, filed Jun. 30, 2016, and U.S. Provisional Application No. 62/360,802, filed Jul. 11, 2016.

The disclosures of the referenced applications are incorporated herein by reference.

COPYRIGHT AUTHORIZATION

The present disclosure may be subject to copyright protection. The copyright owner has no objection to the facsimile reproduction by anyone of the present disclosure and its related documents, as they appear in the Patent and Trademark Office patent files or records, but otherwise reserves all applicable copyrights.

FIELD

The present disclosure generally relates to sports equipment and, more particularly, to golf club heads and methods to manufacture golf club heads.

BACKGROUND

In golf, various factors may affect the distance and direction that a golf ball may travel. In particular, the center of gravity (CG) and/or the moment of inertia (MOI) of a golf club head may affect the launch angle, the spin rate, and the direction of the golf ball at impact. Such factors may vary significantly based the type of golf swing.

BRIEF DESCRIPTION OF THE DRAWINGS

FIG. 1 is top perspective view of an example golf club head according to an embodiment of the apparatus, methods, and articles of manufacture described herein.

FIG. 2 depicts a bottom perspective view of the example golf club head of FIG. 1.

FIG. 3 depicts a top view of the example golf club head of FIG. 1.

FIG. 4 depicts a bottom view of the example golf club head of FIG. 1.

FIG. 5 depicts a front view of the example golf club head of FIG. 1.

FIG. 6 depicts a rear view of the example golf club head of FIG. 1.

FIG. 7 depicts a toe view of the example golf club head of FIG. 1.

FIG. 8 depicts a heel view of the example golf club head of FIG. 1.

FIG. 9 depicts a bottom view of an example body portion of the example golf club head of FIG. 1.

FIG. 10 depicts a cross-sectional view of the example body portion of the example golf club head of FIG. 1.

FIG. 11 depicts two weight ports of the example golf club head of FIG. 1.

FIG. 12 depicts a top view of an example weight portion of the example golf club head of FIG. 1.

FIG. 13 depicts a side view of the example weight portion of FIG. 10.

FIG. 14 depicts example launch trajectory profiles of the example golf club head of FIG. 1.

FIG. 15 depicts a first weight configuration of the example weight portions.

FIG. 16 depicts a second weight configuration of the example weight portions.

FIG. 17 depicts a third weight configuration of the example weight portions.

FIG. 18 depicts a fourth weight configuration of the example weight portions.

FIG. 19 depicts an example launch trajectory profile of the example golf club head of FIG. 18.

FIG. 20 depicts one manner in which the example golf club heads described herein may be manufactured.

FIG. 21 depicts a bottom view of another example golf club head.

FIG. 22 depicts a bottom view of yet another example golf club head.

FIG. 23 is top perspective view of an example golf club head according to an embodiment of the apparatus, methods, and articles of manufacture described herein.

FIG. 24 depicts a bottom perspective view of the example golf club head of FIG. 23.

FIG. 25 depicts a side perspective view of the example golf club head of FIG. 23.

FIG. 26 depicts a side perspective view of the example golf club head of FIG. 23.

FIG. 27 is top perspective view of an example golf club head according to an embodiment of the apparatus, methods, and articles of manufacture described herein.

FIG. 28 depicts a bottom perspective view of the example golf club head of FIG. 27.

FIG. 29 depicts a heel-side perspective view of the example golf club head of FIG. 27.

FIG. 30 depicts a toe-side perspective view of the example golf club head of FIG. 27.

FIG. 31 is a top view of another example golf club head according to an embodiment of the apparatus, methods, and articles of manufacture described herein.

FIG. 32 depicts a bottom view of the example golf club head of FIG. 31.

FIG. 33 depicts a heel view of the example golf club head of FIG. 31.

FIG. 34 depicts a toe view of the example golf club head of FIG. 31.

FIG. 35 depicts a rear view of the example golf club head of FIG. 31.

FIG. 36 depicts a cross-sectional view of the example golf club head of FIG. 31 taken at section lines 36-36 of FIG. 32.

For simplicity and clarity of illustration, the drawing figures illustrate the general manner of construction, and descriptions and details of well-known features and techniques may be omitted to avoid unnecessarily obscuring the present disclosure. Additionally, elements in the drawing figures are not necessarily drawn to scale. For example, the dimensions of some of the elements in the figures may be exaggerated relative to other elements to help improve understanding of embodiments of the present disclosure.

DESCRIPTION

In general, golf club heads and methods to manufacture golf club heads are described herein. The apparatus, methods, and articles of manufacture described herein are not limited in this regard.

In the example of FIGS. 1-13, a golf club head **100** may include a body portion **110**, and a plurality of weight portions **120**, generally, shown as a first set of weight portions **210** (FIG. 2) and a second set of weight portions **220** (FIG. 2). The body portion **110** may include a top portion **130**, a bottom portion **140**, a toe portion **150**, a heel portion **160**, a front portion **170**, and a rear portion **180**. The bottom portion **140** may include a skirt portion **190** defined as a side portion of the golf club head **100** between the top portion **130** and the bottom portion **140** excluding the front portion **170** and extending across a periphery of the golf club head **100** from the toe portion **150**, around the rear portion **180**, and to the heel portion **160**. The bottom portion **140** may include a transition region **230** and a weight port region **240**. For example, the weight port region **240** may be a D-shape region. The weight port region **240** may include a plurality of weight ports **900** (FIG. 9) to receive the plurality of weight portions **120**. The front portion **170** may include a face portion **175** to engage a golf ball (not shown). The body portion **110** may also include a hosel portion **165** to receive a shaft (not shown). Alternatively, the body portion **110** may include a bore instead of the hosel portion **165**. For example, the body portion **110** may be made partially or entirely of an aluminum-based material, a magnesium-type material, a steel-based material, a titanium-based material, any combination thereof, or any other suitable material. In another example the body portion **110** may be made partially or entirely of a non-metal material such as a ceramic material, a composite material, any combination thereof, or any other suitable material.

The golf club head **100** may have a club head volume greater than or equal to 300 cubic centimeters (cm³ or cc). In one example, the golf club head **100** may be about 460 cc. Alternatively, the golf club head **100** may have a club head volume less than or equal to 300 cc. In particular, the golf club head **100** may have a club head volume between 100 cc and 200 cc. The club head volume of the golf club head **100** may be determined by using the weighted water displacement method (i.e., Archimedes Principle). For example, procedures defined by golf standard organizations and/or governing bodies such as the United States Golf Association (USGA) and/or the Royal and Ancient Golf Club of St. Andrews (R&A) may be used for measuring the club head volume of the golf club head **100**. Although FIG. 1 may depict a particular type of club head (e.g., a driver-type club head), the apparatus, methods, and articles of manufacture described herein may be applicable to other types of club head (e.g., a fairway wood-type club head, a hybrid-type club head, an iron-type club head, a putter-type club head, etc.). The apparatus, methods, and articles of manufacture described herein are not limited in this regard.

Each of the first set of weight portions **210**, generally shown as **405**, **410**, **415**, **420**, **425**, **430**, and **435** (FIG. 4), may be associated with a first mass. Each of the second set of weight portions **220**, generally shown as **440**, **445**, **450**, **455**, **460**, **465**, **470**, **475**, and **480** (FIG. 4), may be associated with a second mass. The first mass may be greater than the second mass or vice versa. In one example, the first set of weight portions **210** may be made of a tungsten-based material whereas the second set of weight portions **220** may be made of an aluminum-based material. As described in detail below, the first and second set of weight portions **210** and **220**, respectively, may provide various weight configurations (e.g., FIGS. 15-18).

Referring to FIGS. 9-11, for example, the bottom portion **140** of the body portion **110** may include a plurality of weight ports **900**. The plurality of weight ports **900**, gener-

ally shown as **905**, **910**, **915**, **920**, **925**, **930**, **935**, **940**, **945**, **950**, **955**, **960**, **965**, **970**, **975**, and **980**, may be located along a periphery of the weight port region **240** of the bottom portion **140**. The plurality of weight ports **900** may extend across the bottom portion **140**. In particular, the plurality of weight ports **900** may extend between the toe and heel portions **150** and **160**, respectively, across the bottom portion **140**. The plurality of weight ports **900** may also extend between the front and rear portions **170** and **180**, respectively, across the bottom portion **140**. The plurality of weight ports **900** may be arranged across the bottom portion **140** along a path that defines a generally D-shaped loop. In one example, the plurality of weight ports **900** may extend more than 50% of a maximum toe-to-heel distance **500** between of the toe and heel portions **150** and **160**, respectively, across the bottom portion **140**. The maximum toe-to-heel distance **500** of the golf club head **100** may be measured from transition regions between the top and bottom portions **130** and **140**, respectively, at the toe and heel portions **150** and **160**, respectively. Alternatively, the maximum toe-to-heel distance **500** may be a horizontal distance between vertical projections of the outermost points of the toe and heel portions **150** and **160**, respectively. For example, the maximum toe-to-heel distance **500** may be measured when the golf club head **100** is at a lie angle **510** of about 60 degrees. If the outermost point of the heel portion **160** is not readily defined, the outermost point of the heel portion **160** may be located at a height **520** of about 0.875 inches (22.23 millimeters) above a ground plane **530** (i.e., a horizontal plane on which the golf club head **100** is lying on). The plurality of weight ports **900** may extend more than 50% of a maximum toe-to-heel club head distance **500** of the golf club head **100**. In particular, the plurality of weight ports **900** may extend between the toe portion **150** and the heel portion **160** at a maximum toe-to-heel weight port distance **995**, which may be more than 50% of the maximum toe-to-heel club head distance **500** of the golf club head **100**. In one example, the maximum toe-to-heel club head distance **500** of the golf club head **100** may be no more than 5 inches (127 millimeters). Accordingly, the plurality of weight ports **900** may extend a weight port maximum toe-to-heel weight port distance of at least 2.5 inches between the toe and heel portions **150** and **160**, respectively. A maximum toe-to-heel weight port distance **995** may be the maximum distance between the heel-side boundary of the weight port farthest from the toe portion **150** and the toe-side boundary of the weight port farthest from the heel portion **160**. In the example of FIG. 9, the weight port maximum toe-to-heel weight port distance **995** may be the maximum distance between the heel-side boundary of the weight port **940** and toe-side boundary of the weight port **980**. For example, the maximum toe-to-heel weight port distance **995** may be about 3.7 inches. As the rules of golf may change from time to time (e.g., new regulations may be adopted or old rules may be eliminated or modified by golf standard organizations and/or governing bodies), the lie angle **510** and/or the height **520** for measuring the maximum toe-to-heel club head distance **500** may also change. The apparatus, methods, and articles of manufacture described herein are not limited in this regard.

Each of the plurality of weight ports **900** may be associated with a port diameter (D_{port}) (e.g., two shown as **1105** and **1110** in FIG. 11). For example, the port diameter of each weight port of the plurality of weight ports **900** may be about 0.3 inch (7.65 millimeters). Alternatively, the port diameters of adjacent weight ports may be different. In one example, the weight port **905** may be associated with a port diameter **1105**, and the weight port **910** may be associated with a port

diameter **1110**. In particular, the port diameter **1105** of the weight port **905** may be larger than the port diameter **1110** of the weight port **910** or vice versa. The apparatus, methods, and articles of manufacture described herein are not limited in this regard.

The bottom portion **140** may also include an outer surface **990**. As illustrated in FIG. **10**, for example, the plurality of weight ports **900** may be formed on the bottom portion **140** relative to an outer surface curve **1090** formed by the outer surface **990**. In particular, each of the plurality of weight ports **900** may be associated with a port axis generally shown as **1005**, **1010**, and **1015**. A center of a weight port may define the port axis of the weight port. Each port axis may be perpendicular or substantially perpendicular to a plane that is tangent to the outer surface curve **1090** at the point of intersection of the port axis and the outer surface curve **1090**. In one example, substantially perpendicular may refer to a deviation of $\pm 5^\circ$ from perpendicular. In another example, substantially perpendicular may refer to a deviation of $\pm 3^\circ$ from perpendicular. The deviation from perpendicular may depend on manufacturing tolerances.

In one example, the port axis **1010** may be perpendicular or substantially perpendicular (i.e., normal) to a tangent plane **1012** of the outer surface curve **1090**. Multiple fixtures may be used to manufacture the plurality of weight ports **900** by positioning the golf club head **100** in various positions. Alternatively, the weight ports may be manufactured by multiple-axis machining processes, which may be able to rotate the golf club head around multiple axes to mill away excess material (e.g., by water jet cutting and/or laser cutting) to form the plurality of weight ports **900**. Further, multiple-axis machining processes may provide a suitable surface finish because the milling tool may be moved tangentially about a surface. Accordingly, the apparatus, methods, and articles of manufacture described herein may use a multiple-axis machining process to form each of the plurality of weight ports **900** on the bottom portion **140**. For example, a five-axis milling machine may form the plurality of weight ports **900** so that the port axis **1000** of each of the plurality of weight ports **900** may be perpendicular or substantially perpendicular to the outer surface curve **1090**. The tool of the five-axis milling machine may be moved tangentially about the outer surface curve **1090** of the outer surface **990**.

Turning to FIG. **11**, for example, two adjacent weight ports may be separated by a port distance **1100**, which may be the shortest distance between two adjacent weight ports on the outer surface **990**. In particular, the port distance **1100** may be less than or equal to the port diameter of any of the two adjacent weight ports. In one example, the port distance **1100** between the weight ports **905** and **910** may be less than or equal to either the port diameter **1105** or the port diameter **1110**. The apparatus, methods, and articles of manufacture described herein are not limited in this regard.

The plurality of weight portions **120** may have similar or different physical properties (e.g., density, shape, mass, volume, size, color, etc.). In one example, the first set of weight portions **210** may be a black color whereas the second set of weight portions **220** may be a gray color or a steel color. Some or all of the plurality of weight portions **120** may be partially or entirely made of a metal material such as a steel-based material, a tungsten-based material, an aluminum-based material, any combination thereof or suitable types of materials. Alternatively, some or all of the plurality of weight portions **120** may be partially or entirely made of a non-metal material (e.g., composite, plastic, etc.).

In the illustrated example as shown in FIGS. **12** and **13**, each weight portion of the plurality of weight portions **120**

may have a cylindrical shape (e.g., a circular cross section). Although the above examples may describe weight portions having a particular shape, the apparatus, methods, and articles of manufacture described herein may include weight portions of other suitable shapes (e.g., a portion of or a whole sphere, cube, cone, cylinder, pyramid, cuboidal, prism, frustum, or other suitable geometric shape). Each weight portion of the plurality of weight portions **120** may be associated with a diameter **1200** and a height **1300**. In one example, each weight portion of the plurality of weight portions **120** may have a diameter of about 0.3 inch (7.62 millimeters) and a height of about 0.2 inch (5.08 millimeters). Alternatively, the first and second sets of weight portions **210** and **220**, respectively, may be different in width and/or height.

Instead of a rear-to-front direction as in other golf club heads, each weight portion of the plurality of weight portions **120** may engage one of the plurality of weight ports **400** in a bottom-to-top direction. The plurality of weight portions **120** may include threads to secure in the weight ports. For example, each weight portion of the plurality of weight portions **120** may be a screw. The plurality of weight portions **120** may not be readily removable from the body portion **110** with or without a tool. Alternatively, the plurality of weight portions **120** may be readily removable (e.g., with a tool) so that a relatively heavier or lighter weight portion may replace one or more of the plurality of weight portions **120**. In another example, the plurality of weight portions **120** may be secured in the weight ports of the body portion **110** with epoxy or adhesive so that the plurality of weight portions **120** may not be readily removable. In yet another example, the plurality of weight portions **120** may be secured in the weight ports of the body portion **110** with both epoxy and threads so that the plurality of weight portions **120** may not be readily removable. Further, one or more weight portions of the plurality of weight portions **120** may include a marking corresponding to the mass of the weight portion (e.g., on the bottom of the weight portion). In one example, a weight portion may include a laser-etched marking of "2.4" on the bottom to indicate that the weight portion is 2.4 grams. The apparatus, methods, and articles of manufacture described herein are not limited in this regard.

In contrast to other golf club heads, the golf club head **100** may accommodate at least four different types of golf swings. As illustrated in FIG. **14**, for example, each weight configuration may be associated with one of the plurality of launch trajectory profiles **1400**, generally shown as **1410**, **1420**, and **1430**. Referring to FIG. **15**, for example, a first weight configuration **1500** may be associated with a configuration of a first set of weight portions **1510**. The first set of weight portions **1510** may be located at or proximate to the front portion **170** (e.g., weight ports **905**, **910**, **915**, **920**, **925**, **930**, and **935** shown in FIG. **9**). In the first weight configuration **1500**, a first set of weight portions may be disposed toward the front portion **170** according to the configuration of the first set of weight portions **1510**, whereas a second set of weight portions may be disposed toward the rear portion **180**. In particular, the first set of weight portions may form a cluster according to the configuration of the first set of weight portions **1510** at or proximate to the front portion **170**. The weight portions **405**, **410**, **415**, **420**, **425**, **430**, and **435** may define the first set of weight portions and may be disposed in weight ports **905**, **910**, **915**, **920**, **925**, **930**, and **935**, respectively. The weight portions **440**, **445**, **450**, **455**, **460**, **465**, **470**, **475**, and **480** may define the second set of weight portions and may be disposed in weight ports **940**, **945**, **950**, **955**, **960**, **965**, **970**, **975**, and **980**, respectively. The

first weight configuration **1500** may be associated with the first launch trajectory profile **1410** (FIG. **14**). In particular, the first weight configuration **1500** may decrease spin rate of a golf ball. By placing relatively heavier weight portions (i.e., the first set of weight portions) towards the front portion **170** of the golf club head **100** according to the configuration of the first set of weight ports **1510**, the center of gravity (GC) of the golf club head **100** may move relatively forward and lower to produce a relatively lower launch and spin trajectory. As a result, the first launch trajectory profile **1410** may be associated with a relatively greater roll distance (i.e., distance after impact with the ground). While the above example may describe the weight portions being disposed in certain weight ports, any weight portion of the first set of weight portions **210** may be disposed in any weight port of the first set of weight ports **1510**.

Turning to FIG. **16**, for example, a second weight configuration **1600** may be associated with a configuration of a second set of weight ports **1610**. The second set of weight ports **1610** may be located at or proximate to the rear portion **180** (e.g., weight ports, **945**, **950**, **955**, **960**, **965**, **970**, and **975** shown in FIG. **9**). In a second weight configuration **1600** as illustrated in FIG. **16**, for example, a first set of weight portions may be disposed toward the rear portion **180** whereas a second set of weight portions may be disposed toward the front portion **170**. In particular, the first set of weight portions may form a cluster **1610** at or proximate to the rear portion **180** according to the configuration of the second set of weight ports **1610**. The weight portions **405**, **410**, **415**, **420**, **425**, **430**, and **435** may define the first set of weight portions and may be disposed in weight ports **945**, **950**, **955**, **960**, **965**, **970**, and **975**, respectively. The weight portions **440**, **445**, **450**, **455**, **460**, **465**, **470**, **475**, and **480** may define the second set of weight portions and may be disposed in weight ports **905**, **910**, **915**, **920**, **925**, **930**, **935**, **940**, and **980**, respectively. The second weight configuration **1600** may be associated with the second launch trajectory profile **1420** (FIG. **14**). In particular, the second weight configuration **1600** may increase launch angle of a golf ball and maximize forgiveness. By placing the relatively heavier weight portion (i.e., the first set of weight portions) towards the rear portion **180** of the golf club head **100** according to the configuration of the second set of weight ports **1610**, the center of gravity (GC) of the golf club head **100** may move relatively back and up to produce a relatively higher launch and spin trajectory. Further, the moment of inertia (MOI) of the golf club head **100** may increase in both the horizontal (front-to-back axis) and vertical axes (top-to-bottom axis), which in turn, provides relatively more forgiveness on off-center hits. As a result, the second launch trajectory profile **1420** may be associated with a relatively greater carry distance (i.e., in-the-air distance).

Turning to FIG. **17**, for example, a third weight configuration **1700** may be associated with a configuration of a third set of weight ports **1710**. In the third weight configuration **1700**, for example, a first set of weight portions may be disposed toward the heel portion **160** whereas a second set of weight portions may be disposed toward the toe portion **150**. In particular, the first set of weight portions may form a cluster of weight portions at or proximate to the heel portion **160** according to the configuration of the third set of weight ports **1710**. The weight portions **405**, **410**, **415**, **420**, **425**, **430**, and **435** may define the first set of weight portions and may be disposed in weight ports **925**, **930**, **935**, **940**, **945**, **950**, and **955**, respectively. The weight portions **440**, **445**, **450**, **455**, **460**, **465**, **470**, **475**, and **480** may define the

second set of weight portions and may be disposed in weight ports **905**, **910**, **915**, **920**, **960**, **965**, **970**, **975**, and **980**, respectively. The third weight configuration **1700** may be associated with a third launch trajectory profile **1430** (FIG. **14**). In particular, the third weight configuration **1700** may allow an individual to turn over the golf club head **100** relatively easier (i.e., square up the face portion **175** to impact a golf ball). By placing the relatively heavier weight portions (i.e., the first set of weight portions) towards the heel portion **160** of the golf club head **100**, the center of gravity (GC) of the golf club head **100** may move relatively closer to the axis of the shaft.

Turning to FIG. **18**, for example, a fourth weight configuration **1800** may be associated with a configuration of a fourth set of weight ports **1810**. In a fourth weight configuration **1800**, for example, a first set of weight portions may be disposed toward the toe portion **150** whereas a second set of weight portions may be disposed toward the heel portion **160**. In particular, the first set of weight portions may form a cluster of weight portions at or proximate to the toe portion **150** according to the configuration of the fourth set of weight ports **1810**. The weight portions **405**, **410**, **415**, **420**, **425**, **430**, and **435** may define the first set of weight portions and may be disposed in weight ports **905**, **910**, **915**, **965**, **970**, **975**, and **980**, respectively. The weight portions **440**, **445**, **450**, **455**, **460**, **465**, **470**, **475**, and **480** may define the second set of weight portions and may be disposed in weight ports **920**, **925**, **930**, **935**, **940**, **945**, **950**, **955**, and **960**, respectively. The fourth weight configuration **1800** may be associated with the third launch trajectory profile **1430** (FIG. **14**). In particular, the fourth weight configuration **1800** may prevent an individual from turning over the golf club head **100** (i.e., the face portion **175** may be more open to impact a golf ball). By placing the relatively heavier weight portions (i.e., the first set of weight portions) towards the toe portion **150** of the golf club head **100**, the center of gravity (GC) of the golf club head **100** may move relatively farther away from the axis of the shaft. The fourth weight configuration **1800** may result in a fade golf shot (as shown in FIG. **19**, for example, a trajectory or ball flight in which a golf ball travels to the left of a target **1910** and curving back to the right of the target for a right-handed individual). The apparatus, methods, and articles of manufacture described herein are not limited in this regard.

FIG. **20** depicts one manner in which the golf club head **100** may be manufactured. In the example of FIG. **20**, the process **2000** may begin with providing a plurality of weight portions (block **2010**). The plurality of weight portions may include a first set of weight portions and a second set of weight portions. Each weight portion of the first set of weight portions may be associated with a first mass whereas each weight portion of the second set of weight portions may be associated with a second mass. The first mass may be greater than the second mass. In one example, each weight portion of the first set of weight portions may be made of a tungsten-based material with a mass 2.6 grams whereas each weight portion of the second set of weight portions may be made of an aluminum-based material with a mass of 0.4 grams. Each weight portion of the first set weight portions may include a marking to indicate the corresponding mass (e.g., "2.6" for 2.6 grams). In a similar manner, each weight portion of the second set of weight portions may include a marking to indicate the corresponding mass (e.g., "0.4" for 0.4 grams). The first set of weight portions may have a gray color or a steel color whereas the second set of weight portions may have a black color.

The process 2000 may provide a body portion of a golf club head (block 2020). The body portion may include a front portion, a rear portion, a toe portion, a heel portion, a top portion, a bottom portion having an outer surface associated with outer surface curve, and a skirt portion between the top and bottom portion.

The process 2000 may form a weight port region located at or proximate to the bottom and skirts portions (block 2030). A transition region may surround the weight port region.

The process 2000 may form a plurality of weight ports along a periphery of the weight port region (block 2040). Each weight port of the plurality of weight ports may be associated with a port diameter and configured to receive at least one weight portion of the plurality of weight portions. Two adjacent weight ports may be separated by less than or equal to the port diameter. Further, each weight port of the plurality of weight ports may be associated with a port axis. The port axis may be perpendicular or substantially perpendicular relative to a tangent plane of the outer surface curve of the bottom portion of the golf club head.

The example process 2000 of FIG. 20 is merely provided and described in conjunction with FIGS. 1-19 as an example of one way to manufacture the golf club head 100. While a particular order of actions is illustrated in FIG. 20, these actions may be performed in other temporal sequences. For example, two or more actions depicted in FIG. 20 may be performed sequentially, concurrently, or simultaneously. Although FIG. 20 depicts a particular number of blocks, the process may not perform one or more blocks. The apparatus, methods, and articles of manufacture described herein are not limited in this regard.

As shown in the above examples, the plurality of weight portions 120 and the plurality of weight ports 900 may be located on a periphery of the weight port region 240 along a path that defines a generally D-shaped loop formed with two arcs, generally shown as 490 and 495 in FIG. 4. For example, the weight portions 405, 410, 415, 420, 425, 430, and 435 (FIG. 4), and the weight ports 905, 910, 915, 920, 925, 930, and 935 (FIG. 9) may form the first arc 490. In particular, the first arc 490 may extend between the toe and heel portions 150 and 160, respectively, across the bottom portion 140. The weight portions 440, 445, 450, 455, 460, 465, 470, 475, and 480 (FIG. 4), the weight ports 940, 945, 950, 955, 960, 965, 970, 975, and 980 (FIG. 9) may form the second arc 495. The second arc 495 may generally follow the contour of the rear portion 180 of the body portion 110. Alternatively, the first and second arcs 490 and 495 may define loops with other shapes that extend across the bottom portion 140 (e.g., a generally O-shaped loop). The apparatus, methods, and articles of manufacture described herein are not limited in this regard.

Although the above examples may depict the plurality of weight portions 120 and the plurality of weight ports 900 forming a particular geometric shape, the apparatus, methods, and articles of manufacture described herein may have weight portions and weight ports located along a periphery of a weight portion region to form other geometric shapes. Turning to FIG. 21, for example, a golf club head 2100 may include a bottom portion 2110, and a plurality of weight portions 2120 disposed in a plurality of weight ports 2130. The plurality of weight ports 2130 may be located along a periphery of a weight port region 2140 of the bottom portion 2110 (i.e., the plurality of weight ports 2130 may extend between the toe and heel portions 2112 and 2114, respectively, across the bottom portion 2110). In contrast to the plurality of weight portions 120 and the plurality of weight

ports 900 (e.g., FIGS. 4 and 9), the plurality of weight ports 2130 may form two discrete arcs, generally shown as 2150 and 2155, extending across the bottom portion 2110.

The first arc 2150 may extend between the toe portion 2112 and the heel portion 2114. The first arc 2150 may curve toward the front portion 2170 of the golf club head 2100 (i.e., concave relative to the front portion 2170). According to the example of FIG. 21, the first arc 2150 may extend from a region proximate the toe portion 2112 to a region proximate to the front portion 2170 and from the region proximate to the front portion 2170 to a region proximate to the heel portion 2114 (i.e., concave relative to the front portion 2170). Accordingly, the first arc 2150 may appear as a C-shaped arc facing the rear portion 2180 of the golf club head 2100 that extends between the toe portion 2112 and the heel portion 2114. The second arc 2155 may also extend between the toe portion 2112 and the heel portion 2114. The second arc 2155 may curve toward the rear portion 2180 of the golf club head 2100 (i.e., concave relative to the rear portion 2180). Accordingly, the second arc 2155 may appear as a C-shaped arc facing the front portion 2170 of the golf club head 2100 that extends between the toe portion 2112 and the heel portion 2114. Further, the first arc 2150 may be closer to the front portion 2170 than the second arc 2155. The first arc 2150 and the second arc 2155 may be discrete so that the first and second arcs 2150 and 2155, respectively, may be spaced apart along the periphery of the bottom portion 2110. Accordingly, the bottom portion 2110 may include gaps 2190 and 2192 along the periphery of the bottom portion 2110 between the weight ports 2130 of the first arc 2150 and the weight ports 2130 of the second arc 2155. The gaps 2190 and/or 2192 may be greater than or equal to the port diameter of any of the weight ports 2130 such as the weight ports 2130 that are adjacent to the gaps 2190 and/or 2192. According to one example as shown in FIG. 21, the gaps 2190 and 2192 may be several orders or magnitude larger than the diameters of the weight ports 2130 that are adjacent to the gaps 2190 and 2192. The apparatus, methods, and articles of manufacture described herein are not limited in this regard.

Referring to FIG. 21, for example, the first arc 2150 may include a greater number of weight ports 2130 than the second arc 2155, which may be suitable for certain golf club heads (e.g., a fairway wood-type golf club head and/or a hybrid-type golf club head). Alternatively, the second arc 2155 may include the same or a greater number of weight ports 2130 than the first arc 2150. The number of weight ports 2130 in each of the first and second arcs 2150 and 2155, respectively, the weight portions 2120 associated with each weight port 2130 and the spacing between adjacent weight ports 2130 may be determined based on the type of golf club, a preferred weight distribution of the golf club head 2100, and/or a center of gravity location of the golf club head 2100.

The weight ports 2130 of the first arc 2150 and/or the second arc 2155 may be spaced from each other at the same or approximately the same distance along the first arc 2150 and/or the second arc 2155, respectively. Any variation in the spacing between the weight ports 2130 of the first arc 2150 or the second arc 2155 or any of the weight ports described herein may be due to different manufacturing considerations, such as manufacturing tolerances and/or cost effectiveness associated with manufacturing precision. For example, the variation in the spacing between the weight ports 2130 of the first arc 2150 and/or the second arc 2155 may be between $\frac{1}{16}$ of an inch to 0.001 inch. As described herein, the distance between adjacent weight ports 2130

(i.e., port distance) may be less than or equal to the port diameter of any of the two adjacent weight ports. The plurality of weight ports **2130** may extend between the toe portion **2112** and the heel portion **2114** at a maximum toe-to-heel weight port distance that is more than 50% of a maximum toe-to-heel club head distance **2195** of the golf club head **2100**. The maximum toe-to-heel weight port distance may be the maximum distance between the heel-side boundary of the weight port farthest from the toe portion **2112** and the toe-side boundary of the weight port farthest from the heel portion **2114**.

In particular, the golf club head **2100** may have a volume of less than 430 cc. In example, the golf club head **2100** may have a volume ranging from 100 cc to 400 cc. In another example, the golf club head **2100** may have a volume ranging from 150 cc to 350 cc. In yet another example, the golf club head **2100** may have a volume ranging from 200 cc to 300 cc. The golf club head **2100** may have a mass ranging from 100 grams to 350 grams. In another example, the golf club head **2100** may have a mass ranging from 150 grams to 300 grams. In yet another example, the golf club head **2100** may have a mass ranging from 200 grams to 250 grams. The golf club head **2100** may have a loft angle ranging from 10° to 30°. In another example, the golf club head **2100** may have a loft angle ranging from 13° to 27°. For example, the golf club head **2100** may be a fairway wood-type golf club head. Alternatively, the golf club head **2100** may be a smaller driver-type golf club head (i.e., larger than a fairway wood-type golf club head but smaller than a driver-type golf club head). The apparatus, methods, and articles of manufacture described herein are not limited in this regard.

As illustrated in FIG. 22, for example, a golf club head **2200** may include a bottom portion **2210**, and a plurality of weight portions **2220** disposed in a plurality of weight ports **2230**. The plurality of weight ports **2230** located along a periphery of a weight port region **2240** may be arranged along a path that defines an arc, generally shown as **2250**, extending across the bottom portion **2210** (i.e., the plurality of weight ports **2230** may extend between the toe and heel portions **2212** and **2214**, respectively, across the bottom portion **2210**). The arc **2250** may curve toward the rear portion **2280** of the golf club head **2200** (i.e., concave relative to the rear portion **2280**). According to the example of FIG. 22, the arc **2250** may extend from a region proximate the toe portion **2212** to a region proximate to the rear portion **2280** and from the region proximate to the rear portion **2280** to a region proximate to the heel portion **2214** (i.e., concave relative to the rear portion **2280**). Accordingly, the arc **2250** may appear as a C-shaped arc facing the front portion **2270** of the golf club head **2200** that extends from near the heel portion **2214** to near the toe portion **2212**. Further, the curvature of the arc **2250** is substantially similar to or generally follows the contour of the rear portion **2280** of the golf club head **2200**. The number of weight ports **2230** in the arc **2250**, the weight portions **2220** associated with each weight port **2230** and the spacing between adjacent weight ports **2230** may be determined based on the type of golf club, a preferred weight distribution of the golf club head **2200**, and/or a center of gravity location of the golf club head **2200**.

The weight ports **2230** of the arc **2250** may be spaced from each other at the same or approximately the same distance along the arc **2250** (e.g., the weight ports **2230** may be substantially similarly spaced apart from each other). Any variation in the spacing between the weight ports **2230** of the arc **2250** or any of the weight ports described herein may be

due to different manufacturing considerations, such as manufacturing tolerances and/or cost effectiveness associated with manufacturing precision. For example, the variation in the spacing between the weight ports **2130** of the arc **2250** may be between 1/16 of an inch to 0.001 inch. As described herein, the distance between adjacent weight ports **2230** (i.e., port distance) may be less than or equal to the port diameter of any of the two adjacent weight ports. The plurality of weight ports **2230** may extend between the toe portion **2212** and the heel portion **2214** at a maximum toe-to-heel weight port distance that is more than 50% of a maximum toe-to-heel club head distance of **2290** the golf club head **2200**. The maximum toe-to-heel weight port distance may be the maximum distance between the heel-side boundary of the weight port farthest from the toe portion **2212** and the toe-side boundary of the weight port farthest from the heel portion **2214**.

In particular, the golf club head **2200** may have a volume of less than 200 cc. In example, the golf club head **2200** may have a volume ranging from 50 cc to 150 cc. In another example, the golf club head **2200** may have a volume ranging from 60 cc to 120 cc. In yet another example, the golf club head **2200** may have a volume ranging from 70 cc to 100 cc. The golf club head **2200** may have a mass ranging from 180 grams to 275 grams. In another example, the golf club head **2200** may have a mass ranging from 200 grams to 250 grams. The golf club head **2200** may have a loft angle ranging from 15° to 35°. In another example, the golf club head **2200** may have a loft angle ranging from 17° to 33°. For example, the golf club head **2200** may be a hybrid-type golf club head. The apparatus, methods, and articles of manufacture described herein are not limited in this regard.

In the example of FIGS. 23-26, a golf club head **2300** may include a body portion **2310**, which may include a top portion **2330**, a bottom portion **2340**, a toe portion **2350**, a heel portion **2360**, a front portion **2370** with a face portion **2375** to engage a golf ball (not shown), and a rear portion **2380**. The body portion **2310** may include a skirt portion **2390** defined as a side portion of the golf club head **2300** between the top portion **2330** and the bottom portion **2340** excluding the front portion **2370** and extending across a periphery of the golf club head **2300** from the toe portion **2350**, around the rear portion **2380**, and to the heel portion **2360**. The body portion **2310** may also include a hosel portion **2365** to receive a shaft (not shown). Alternatively, the body portion **2310** may include a bore instead of the hosel portion **2365**. For example, the body portion **2310** may be made partially or entirely of an aluminum-based material, a magnesium-type material, a steel-based material, a titanium-based material, any combination thereof, or any other suitable material. In another example the body portion **2310** may be made partially or entirely of a non-metal material such as a ceramic material, a composite material, any combination thereof, or any other suitable material.

The golf club head **2300** may have a club head volume greater than or equal to 300 cubic centimeters (cm³ or cc). In one example, the golf club head **2300** may be about 460 cc. Alternatively, the golf club head **2300** may have a club head volume less than or equal to 300 cc. In particular, the golf club head **2300** may have a club head volume between 100 cc and 200 cc. The club head volume of the golf club head **2300** may be determined by using the weighted water displacement method (i.e., Archimedes Principle). For example, procedures defined by golf standard organizations and/or governing bodies such as the United States Golf Association (USGA) and/or the Royal and Ancient Golf Club of St. Andrews (R&A) may be used for measuring the

club head volume of the golf club head **2300**. Although FIGS. **23-26** may depict a particular type of club head (e.g., a driver-type club head), the apparatus, methods, and articles of manufacture described herein may be applicable to other types of golf club heads (e.g., a fairway wood-type club head, a hybrid-type club head, an iron-type club head, a putter-type club head, etc.). The apparatus, methods, and articles of manufacture described herein are not limited in this regard.

The body portion **2310** may be a hollow body having one or more interior cavity portions. In one example, the body portion **2310** may include a first interior cavity portion **2539** and a second interior cavity portion **2540**. The first interior cavity portion **2539** may define the overall volume of the body portion **2310**. The second interior cavity portion **2540** may be in the first interior cavity portion **2530** and define a portion of the overall volume of the body portion **2310**. The first interior cavity portion **2539** and the second interior cavity portion **2540** may be connected. For example, the second interior cavity portion **2540** may have an opening (not shown) to the first interior cavity portion **2539**. In one example, as shown in FIGS. **23-26**, the first interior cavity portion **2539** and the second interior cavity portion **2540** may be separate or have no connection between the internal space thereof. The apparatus, methods, and articles of manufacture described herein are not limited in this regard.

The bottom portion **2340** may include a plurality of weight portions **2420**, which are generally shown as weight portions **2621, 2622, 2623, 2624, 2625, 2626, 2627, 2628** and **2629** (FIG. **24**). The body portion **2310** may include a plurality of weight ports **2440**, which are generally shown as weight ports **2641, 2642, 2643, 2644, 2645, 2646, 2647, 2648** and **2649** (FIG. **24**). For example, as shown in FIG. **24**, each of the weight ports **2440** may extend from the bottom portion **2340** into the first interior cavity portion **2539**. Depending on the position of the weight ports **2440** on the bottom portion **2340**, some or all of the weight ports **2440** may extend into the second interior cavity portion **2540** (not shown) from the bottom portion **2340**. Each of the weight ports **2440** may receive one of the weight portions **2420**. The weight portions **2420**, the weight ports **2440**, the mass of each weight portion **2420**, the mass distribution of the weight portions **2420** on the body portion **2310**, distances between the weight ports **2440**, the materials of construction of the weight portions **2420**, the dimensions of the weight portions **2420**, the shapes of the weight portions **2420**, and/or any other physical properties of any of the weight portions **2420** and/or the weight ports **2440** may be similar in many respects to any of the weight portions and weight ports described herein. For example, each weight port of the weight ports **2440** may have a port diameter that may be similar to the port diameter of an adjacent weight port. For example, the distance between two adjacent weight ports may be less than or equal to the port diameter of any of the two adjacent weight ports. The apparatus, methods, and articles of manufacture described herein are not limited in this regard.

The weight ports **2440** may be arranged on the body portion **2310** in any configuration. In one example, the weight ports **2440** may generally extend between the toe portion **2350** and the heel portion **2360** at a location between the front portion **2370** and the rear portion **2380**. In one example, the weight ports **2440** may extend from the toe portion **2350** to the heel portion **2360** along a line. In the example of FIGS. **23-26**, weight ports **2643, 2644, 2645, 2646,** and **2647** may define a first set of weight ports and extend in a direction from the toe portion **2350** to the heel

portion **2360** at or proximate to a central portion **2341** of the bottom portion **2340**. The weight ports **2641** and **2642** may be closer to the rear portion **2380** than the weight port **2643** and define a second set of weight ports. Accordingly, the weight ports **2641** and **2642** may extend from at or proximate to the central portion **2341** toward the toe portion **2350** and the rear portion **2380**. The weight ports **2648** and **2649** may be closer to the rear portion **2380** than the weight port **2647** and define a third set of weight ports. Accordingly, the weight ports **2648** and **2649** may extend from at or proximate to the central portion **2341** toward the heel portion **2360** and the rear portion **2380**. In one example, the configuration of the plurality of weight ports **2440** may be similar to any one or a combination of the golf club heads described herein. In one example, the plurality of weight ports **2440** may extend along a curve that is concave relative to the front portion **2370**. In one example, the plurality of weight ports **2440** may extend along a curve that is concave relative to the rear portion **2380**. In one example, some or all of the plurality of weight ports **2440** may be closer to the front portion **2370** than the rear portion **2380**. In one example, some or all of the plurality of weight ports **2440** may be closer to the rear portion **2380** than the front portion **2370**. The apparatus, methods, and articles of manufacture described herein are not limited in this regard.

In one example, the weight portions of the plurality of weight portions **2420** may have the same mass. In one example, the weight portions of the plurality of weight portions **2420** may have different masses. In one example, the plurality of weight portions **2420** may include a first set of weight portions (not shown) associated with a first mass and a second set of weight portions (not shown) associated with a second mass. In one example, the plurality of weight portions **2420** may be associated with a plurality of sets of masses. Accordingly, the weight distribution of the body portion **2310** may be configured to any type of weight distribution such as to a toe biased weight distribution, a heel biased weight distribution, a front biased weight distribution, a rear biased weight distribution or various combinations thereof. Thus, the golf club head **2300** may accommodate any individual having any type of golf swing. In one example, the weight distribution of the body portion **2310** may be configured similar to the examples described herein. The apparatus, methods, and articles of manufacture described herein are not limited in this regard.

In one example, the plurality of weight ports **2440** may extend more than 50% of a maximum toe-to-heel distance **2460** between of the toe and heel portions **2350** and **2360**, respectively, across the bottom portion **2340** along a first path **2464**. The maximum toe-to-heel distance **2460** of the golf club head **2300** may be in similar in many respects to the maximum toe-to-heel distance of any of the golf club heads described herein. In one example, the plurality of weight ports **2440** may extend between the toe portion **2350** and the heel portion **2360** at a maximum toe-to-heel weight port distance **2462**, which may be more than 50% of the maximum toe-to-heel distance **2460** of the golf club head **2300**. A maximum toe-to-heel weight port distance **2462** may be the maximum distance between the heel-side boundary of the weight port farthest from the toe portion **2350** and the toe-side boundary of the weight port farthest from the heel portion **2360**. In one example, the plurality of weight ports **2440** may extend between the toe portion **2350** and the heel portion **2360** at a maximum toe-to-heel weight port distance **2462**, which may be more than 60% of the maximum toe-to-heel distance **2460** of the golf club head **2300**. In one example, the plurality of weight ports **2440** may

extend between the toe portion 2350 and the heel portion 2360 at a maximum toe-to-heel weight port distance 2462, which may be more than 70% of the maximum toe-to-heel distance 2460 of the golf club head 2300. In one example, the plurality of weight ports 2440 may extend between the toe portion 2350 and the heel portion 2360 at a maximum toe-to-heel weight port distance 2462, which may be more than 80% of the maximum toe-to-heel distance 2460 of the golf club head 2300. In one example, the plurality of weight ports 2440 may extend between the toe portion 2350 and the heel portion 2360 at a maximum toe-to-heel weight port distance 2462, which may be more than 90% of the maximum toe-to-heel distance 2460 of the golf club head 2300. The apparatus, methods, and articles of manufacture described herein are not limited in this regard.

In one example, the body portion 2310 may include an exterior support portion on the bottom portion 2340. For example, as shown in FIGS. 24-26, the exterior support portion may be a groove portion 2510 on the bottom portion 2340 that may be located between the front portion 2370 and the plurality of weight ports 2440 and extend on the bottom portion 2340 along a second path 2520. The groove portion 2510 may structurally support the bottom portion 2340 when the face portion 2375 strikes a golf ball (not shown). Accordingly, the groove portion 2510 may function as a structural support portion of the golf club head 2300. In one example shown in FIGS. 23-26, the second path 2520 may be similar or substantially similar to the first path 2464 of the plurality of weight ports 2440. Accordingly, the groove portion 2510 may include a first groove portion extending in a direction from the toe portion 2350 to the heel portion 2360 at or proximate to the central portion 2341, a second groove portion extending from the first groove portion toward the toe portion 2350 and the rear portion 2380, and a third groove portion extending from the first groove portion toward the heel portion 2360 and the rear portion 2380. In one example, the first path 2464 and the second path 2520 may be substantially parallel. In one example, the groove portion 2510 may extend between the toe portion 2350 and the heel portion 2360 in a different path than the path of extension of the plurality of weight ports 2440 (e.g. the first path 2464). The body portion 2310 may include additional groove portions on the bottom portion that may provide structural support to the golf club head 2300. Further, the groove portion 2510 may have any physical properties (i.e., depth, width, length, orientation, location, etc.). The apparatus, methods, and articles of manufacture described herein are not limited in this regard.

In one example, the groove portion 2510 may extend between the toe portion 2350 and the heel portion 2360 more than 50% of the maximum toe-to-heel distance 2460 of the golf club head 2300. In one example, the groove portion 2510 may extend between the toe portion 2350 and the heel portion 2360 more than 60% of the maximum toe-to-heel distance 2460 of the golf club head 2300. In one example, the groove portion 2510 may extend between the toe portion 2350 and the heel portion 2360 more than 70% of the maximum toe-to-heel distance 2460 of the golf club head 2300. In one example, the groove portion 2510 may extend between the toe portion 2350 and the heel portion 2360 more than 80% of the maximum toe-to-heel distance 2460 of the golf club head 2300. In one example, the groove portion

2510 may extend between the toe portion 2350 and the heel portion 2360 more than 90% of the maximum toe-to-heel distance 2460 of the golf club head 2300. In one example, the groove portion 2510 may extend between the toe portion 2350 and the heel portion 2360 the same or substantially the same as the maximum toe-to-heel distance 2460 of the golf club head 2300. In one example shown in FIGS. 23-26, the groove portion 2510 may be a single continuous groove portion 2510. In one example, the groove portion 2510 may include a plurality of groove portions (not shown), at least some of which may be discontinuous. The apparatus, methods, and articles of manufacture described herein are not limited in this regard.

The second interior cavity portion 2540 may be located at any location within the body portion 2310. In one example, as shown in FIG. 23-26, the second interior cavity portion 2540 may be located in the body portion 2310 between the plurality of weight ports 2440 and the rear portion 2380. The second interior cavity portion 2540 may be at any location on the body portion 2310 between the plurality of weight ports 2440 and the rear portion 2380. In one example as shown in FIGS. 23-26, the second interior cavity portion 2540 may be in the body portion 2310 at or near the rear portion 2380 and at or near the bottom portion 2340. The second interior cavity portion 2540 may be defined by a recessed portion (not shown) of the bottom portion 2340 that may be covered with a bottom cover portion (not shown). In one example, the second interior cavity portion 2540 may be inside the body portion 2310 and define a portion of the volume of the body portion 2310. In one example, the interior cavity 2540 may have any shape, configuration, length and/or width. The second interior cavity portion 2540 may have a volume that is between about 5% and about 85% of the volume of the body portion 2310. The second interior cavity portion 2540 may have a volume that is between about 5% and about 65% of the volume of the body portion 2310. The second interior cavity portion 2540 may have a volume that is between about 5% and about 45% of the volume of the body portion 2310. The second interior cavity portion 2540 may have a volume that is between about 5% and about 35% of the volume of the body portion 2310. The second interior cavity portion 2540 may have a volume that is between about 5% and about 25% of the volume of the body portion 2310. The second interior cavity portion 2540 may have a volume that is between about 5% and about 10% of the volume of the body portion 2310. The apparatus, methods, and articles of manufacture described herein are not limited in this regard.

In one example, the second interior cavity portion 2540 may be unfilled (i.e., empty space). Alternatively, the second interior cavity portion 2540 may be partially or entirely filled with a filler material that is an elastic polymer or elastomer material and/or other suitable types of materials to absorb shock, isolate vibration, dampen noise, and/or move the center of gravity of the golf club head 2300 lower and farther back. The second interior cavity portion 2540 may be filled from any opening on the body portion 2310 that may be closed after the second interior cavity portion 2540 is filled with the filler material. For example, any one or more of the weight ports 2440 may be connected to the second interior cavity portion 2540. Accordingly, the second interior cavity portion 2540 may be filled with the filler material from the one or more connected weight ports 2440. The apparatus, methods, and articles of manufacture described herein are not limited in this regard.

The filler material may be an elastic polymer or elastomer material (e.g., a viscoelastic urethane polymer material such

as Sorbothane® material manufactured by Sorbothane, Inc., Kent, Ohio), a thermoplastic elastomer material (TPE), a thermoplastic polyurethane material (TPU), and/or other suitable types of materials to absorb shock, isolate vibration, and/or dampen noise. In another example, the filler material may be a high density ethylene copolymer ionomer, a fatty acid modified ethylene copolymer ionomer, a highly amorphous ethylene copolymer ionomer, an ionomer of ethylene acid acrylate terpolymer, an ethylene copolymer comprising a magnesium ionomer, an injection moldable ethylene copolymer that may be used in conventional injection molding equipment to create various shapes, an ethylene copolymer that can be used in conventional extrusion equipment to create various shapes, and/or an ethylene copolymer having high compression and low resilience similar to thermoset polybutadiene rubbers. For example, the ethylene copolymer may include any of the ethylene copolymers associated with DuPont™ High-Performance Resin (HPF) family of materials (e.g., DuPont™ HPF AD1172, DuPont™ HPF AD1035, DuPont® HPF 1000 and DuPont™ HPF 2000), which are manufactured by E.I. du Pont de Nemours and Company of Wilmington, Del. The DuPont™ HPF family of ethylene copolymers are injection moldable and may be used with conventional injection molding equipment and molds, provide low compression, and provide high resilience. The apparatus, methods, and articles of manufacture described herein are not limited in this regard.

The filler material may be bonded, attached and/or connected to all or portions of the interior walls of the second interior cavity portion **2540** by a bonding portion (not shown) to improve adhesion and/or mitigate delamination between the body portion of any of the golf club heads described herein and the filler material. The bonding portion may be a bonding agent, an epoxy, a combination of bonding agents, a bonding structure or attachment device, a combination of bonding structures and/or attachment devices, and/or a combination of one or more bonding agents, one or more bonding structures and/or one or more attachment devices. In one example, the bonding portion may be low-viscosity, organic, solvent-based solutions and/or dispersions of polymers and other reactive chemicals such as MEGUM™, ROBOND™, and/or THIXON™ materials manufactured by the Dow Chemical Company, Auburn Hills, Mich. In another example, the bonding portion may be LOCTITE® materials manufactured by Henkel Corporation, Rocky Hill, Conn. The apparatus, methods, and articles of manufacture are not limited in this regard.

In the example of FIGS. 27-30, a golf club head **2700** may include a body portion **2710**, which may include a top portion **2730**, a bottom portion **2740**, a toe portion **2750**, a heel portion **2760**, a front portion **2770**, and a rear portion **2780**. The body portion **2710** may include a skirt portion **2790** defined as a side portion of the golf club head **2700** between the top portion **2730** and the bottom portion **2740** excluding the front portion **2770** and extending across a periphery of the golf club head **2700** from the toe portion **2750**, around the rear portion **2780**, and to the heel portion **2760**. The front portion **2770** may include a face portion **2775** to engage a golf ball (not shown). The body portion **2710** may also include a hosel portion **2765** to receive a shaft (not shown). Alternatively, the body portion **2710** may include a bore instead of the hosel portion **2765**. For example, the body portion **2710** may be made partially or entirely of an aluminum-based material, a magnesium-type material, a steel-based material, a titanium-based material, any combination thereof, or any other suitable material. In another example the body portion **2710** may be made

partially or entirely of a non-metal material such as a ceramic material, a composite material, any combination thereof, or any other suitable material.

The golf club head **2700** may have a volume of less than 430 cc. In example, the golf club head **2700** may have a volume ranging from 100 cc to 400 cc. In another example, the golf club head **2700** may have a volume ranging from 150 cc to 350 cc. In yet another example, the golf club head **2700** may have a volume ranging from 200 cc to 300 cc. The golf club head **2700** may have a mass ranging from 100 grams to 350 grams. In another example, the golf club head **2700** may have a mass ranging from 150 grams to 300 grams. In yet another example, the golf club head **2700** may have a mass ranging from 200 grams to 250 grams. The golf club head **2700** may have a loft angle ranging from 10° to 30°. In another example, the golf club head **2700** may have a loft angle ranging from 13° to 27°. For example, the golf club head **2700** may be a fairway wood-type golf club head. Alternatively, the golf club head **2700** may be a smaller driver-type golf club head (i.e., larger than a fairway wood-type golf club head but smaller than a driver-type golf club head). The apparatus, methods, and articles of manufacture described herein are not limited in this regard.

The body portion **2710** may be a hollow body having one or more interior cavity portions. In one example, the body portion **2710** may include a first interior cavity portion **2939** and a second interior cavity portion **2940**. The first interior cavity portion **2939** may define the overall volume of the body portion **2710**. The second interior cavity portion **2940** may be in the first interior cavity portion **2939** and define a portion of the overall volume of the body portion **2710**. The first interior cavity portion **2939** and the second interior cavity portion **2940** may be connected. For example, the second interior cavity portion **2940** may have an opening (not shown) to the first interior cavity portion **2939**. In one example, as shown in FIGS. 27-30, the first interior cavity portion **2939** and the second interior cavity portion **2940** may be separate or have no connection between the internal space thereof. The apparatus, methods, and articles of manufacture described herein are not limited in this regard.

The bottom portion **2740** may include a plurality of weight portions **2820**, which are generally shown as weight portions **3021**, **3022**, **3023**, **3024**, **3025**, **3026**, and **3027** (FIG. 28). The body portion **2710** may include a plurality of weight ports **2840**, which are generally shown as weight ports **3041**, **3042**, **3043**, **3044**, **3045**, **3046**, and **3047** (FIG. 28). For example, as shown in FIG. 28, each of the weight ports **2840** may extend from the bottom portion **2740** into the first interior cavity portion **2939**. Depending on the position of the weight ports **2840** on the bottom portion **2740**, some or all of the weight ports **2840** may extend into the second interior cavity portion **2940** (not shown) from the bottom portion **2740**. Each of the weight ports **2840** may receive one of the weight portions **2820**. The weight portions **2820**, the weight ports **2840**, the mass of each weight portion **2820**, the mass distribution of the weight portions **2820** on the body portion **2710**, distances between the weight ports **2840**, the materials of construction of the weight portions **2820**, the dimensions of the weight portions **2820**, the shapes of the weight portions **2820**, and/or any other physical properties of any of the weight portions **2820** and/or the weight ports **2840** may be similar in many respects to any of the weight portions and weight ports described herein. For example, each weight port of the weight ports **2440** may have a port diameter that may be similar to the port diameter of an adjacent weight port. For example, the distance between two adjacent weight ports may be less than or equal

to the port diameter of any of the two adjacent weight ports. The apparatus, methods, and articles of manufacture described herein are not limited in this regard.

The weight ports **2840** may be arranged on the body portion **2710** in any configuration. In one example, the weight ports **2840** may generally extend between the toe portion **2750** and the heel portion **2760** at a location between the front portion **2770** and the rear portion **2780**. For example, the weight ports **2840** may extend from the toe portion **2750** to the heel portion **2760** along a line. In the example of FIGS. **27-30**, weight ports **3043**, **3044**, and **3045** may define a first set of weight ports and extend in a direction from the toe portion **2750** to the heel portion **2760** at or proximate to a central portion **2741** of the bottom portion **2740**. The weight ports **3041** and **3042** may be closer to the rear portion **2780** than the weight port **3043** and define a second set of weight ports. Accordingly, the weight ports **3041** and **3042** may extend from at or proximate to the central portion **2741** toward the toe portion **2750** and the rear portion **2780**. The weight ports **3046** and **3047** may be closer to the rear portion **2780** than the weight port **3045** and define a third set of weight ports. Accordingly, the weight ports **3046** and **3047** may extend from at or proximate to the central portion **2741** toward the heel portion **2760** and the rear portion **2780**. In one example, the configuration of the plurality of weight ports **2840** may be similar to any one or a combination of the golf club heads described herein. In one example, the plurality of weight ports **2840** may extend along a curve that is concave relative to the front portion **2770**. In one example, the plurality of weight ports **2840** may extend along a curve that is concave relative to the rear portion **2780**. In one example, some or all of the plurality of weight ports **2840** may be closer to the front portion **2770** than the rear portion **2780**. In one example, some or all of the plurality of weight ports **2840** may be closer to the rear portion **2780** than the front portion **2770**. The apparatus, methods, and articles of manufacture described herein are not limited in this regard.

In one example, the weight portions of the plurality of weight portions **2820** may have the same mass. In one example, the weight portions of the plurality of weight portions **2820** may have different masses. In one example, the plurality of weight portions **2820** may include a first set of weight portions (not shown) associated with a first mass and a second set of weight portions (not shown) associated with a second mass. In one example, the plurality of weight portions **2820** may be associated with a plurality of sets of masses. Accordingly, the weight distribution of the body portion **2710** may be configured to any type of weight distribution such as to a toe biased weight distribution, a heel biased weight distribution, a front biased weight distribution, a rear biased weight distribution or various combinations thereof. Thus, the golf club head **2700** may accommodate any individual having any type of golf swing. In one example, the weight distribution of the body portion **2710** may be configured similar to the examples described herein. The apparatus, methods, and articles of manufacture described herein are not limited in this regard.

In one example, the plurality of weight ports **2840** may extend more than 50% of a maximum toe-to-heel distance **2860** between of the toe and heel portions **2750** and **2760**, respectively, across the bottom portion **2740** along a first path **2864**. The maximum toe-to-heel distance **2860** of the golf club head **2700** may be in similar in many respects to the maximum toe-to-heel distance of any of the golf club heads described herein. In one example, the plurality of weight ports **2840** may extend between the toe portion **2750**

and the heel portion **2760** at a maximum toe-to-heel weight port distance **2862**, which may be more than 50% of the maximum toe-to-heel distance **2860** of the golf club head **2700**. A maximum toe-to-heel weight port distance **2862** may be the maximum distance between the heel-side boundary of the weight port farthest from the toe portion **2750** and the toe-side boundary of the weight port farthest from the heel portion **2760**. In one example, the plurality of weight ports **2840** may extend between the toe portion **2750** and the heel portion **2760** at a maximum toe-to-heel weight port distance **2862**, which may be more than 60% of the maximum toe-to-heel distance **2860** of the golf club head **2700**. In one example, the plurality of weight ports **2840** may extend between the toe portion **2750** and the heel portion **2760** at a maximum toe-to-heel weight port distance **2862**, which may be more than 70% of the maximum toe-to-heel distance **2860** of the golf club head **2700**. In one example, the plurality of weight ports **2840** may extend between the toe portion **2750** and the heel portion **2760** at a maximum toe-to-heel weight port distance **2862**, which may be more than 80% of the maximum toe-to-heel distance **2860** of the golf club head **2700**. In one example, the plurality of weight ports **2840** may extend between the toe portion **2750** and the heel portion **2760** at a maximum toe-to-heel weight port distance **2862**, which may be more than 90% of the maximum toe-to-heel distance **2860** of the golf club head **2700**. In one example, the plurality of weight ports **2840** may extend between the toe portion **2750** and the heel portion **2760** at a maximum toe-to-heel weight port distance **2862**, which may be the same or substantially the same as the maximum toe-to-heel distance **2860** of the golf club head **2700**. The apparatus, methods, and articles of manufacture described herein are not limited in this regard.

In one example, the body portion **2710** may include one or more exterior support portion on the bottom portion **2740**. For example, as shown in FIGS. **28-30**, the exterior support portion may be a groove portion **2910** on the bottom portion **2740** that may be located between the front portion **2770** and the plurality of weight ports **2840** and extend on the bottom portion **2740** along a second path **2920**. The groove portion **2910** may structurally support the bottom portion **2740** when the face portion **2775** strikes a golf ball (not shown). Accordingly, the groove portion **2910** may function as a structural support portion of the golf club head **2700**. In one example shown in FIGS. **27-30**, the second path **2920** may be similar or substantially similar to the first path **2864** of the plurality of weight ports **2840**. Accordingly, the groove portion **2910** may include a first groove portion extending in a direction from the toe portion **2750** to the heel portion **2760** at or proximate to the central portion **2741**, a second groove portion extending from the first groove portion toward the toe portion **2750** and the rear portion **2780**, and a third groove portion extending from the first groove portion toward the heel portion **2760** and the rear portion **2780**. In one example, the first path **2864** and the second path **2920** may be substantially parallel. In one example, the groove portion **2910** may extend between the toe portion **2750** and the heel portion **2760** in a different path than the path of extension of the plurality of weight ports **2840** (e.g., the first path **2864**). The body portion **2710** may include additional groove portions on the bottom portion that may provide structural support to the golf club head **2700**. Further, the groove portion **2910** may have any physical properties (i.e., depth, width, length, orientation, location, etc.). The apparatus, methods, and articles of manufacture described herein are not limited in this regard.

In one example, the groove portion 2910 may extend between the toe portion 2750 and the heel portion 2760 more than 50% of the maximum toe-to-heel distance 2860 of the golf club head 2700. In one example, the groove portion 2910 may extend between the toe portion 2750 and the heel portion 2760 more than 60% of the maximum toe-to-heel distance 2860 of the golf club head 2700. In one example, the groove portion 2910 may extend between the toe portion 2750 and the heel portion 2760 more than 70% of the maximum toe-to-heel distance 2860 of the golf club head 2700. In one example, the groove portion 2910 may extend between the toe portion 2750 and the heel portion 2760 more than 80% of the maximum toe-to-heel distance 2860 of the golf club head 2700. In one example, the groove portion 2910 may extend between the toe portion 2750 and the heel portion 2760 more than 90% of the maximum toe-to-heel distance 2860 of the golf club head 2700. In one example, the groove portion 2910 may extend between the toe portion 2750 and the heel portion 2760 the same or substantially the same as the maximum toe-to-heel distance 2860 of the golf club head 2700. In one example shown in FIGS. 27-30, the groove portion 2910 may be a single continuous groove portion 2910. In one example, the groove portion 2910 may include a plurality of groove portions (not shown), at least some of which may be discontinuous. The apparatus, methods, and articles of manufacture described herein are not limited in this regard.

The second interior cavity portion 2940 may be located at any location within the body portion 2710. In one example, as shown in FIG. 27-30, the second interior cavity portion 2940 may be located in the body portion 2710 between the plurality of weight ports 2840 and the rear portion 2780. The second interior cavity portion 2940 may be at any location on the body portion 2710 between the plurality of weight ports 2840 and the rear portion 2780. In one example as shown in FIGS. 27-30, the second interior cavity portion 2940 may be in the body portion 2710 at or near the rear portion 2780 and at or near the bottom portion 2740. The second interior cavity portion 2940 may be defined by a recessed portion (not shown) of the bottom portion 2740 that may be covered with a bottom cover portion (not shown). In one example, the second interior cavity portion 2940 may be inside the body portion 2710 and define a portion of the volume of the body portion 2710. In one example, the interior cavity 2940 may have any shape, configuration, length and/or width. The second interior cavity 2940 portion may have a volume that is between about 5% and about 85% of the volume of the body portion 2710. The second interior cavity portion 2940 may have a volume that is between about 5% and about 65% of the volume of the body portion 2310. The second interior cavity portion 2940 may have a volume that is between about 5% and about 45% of the volume of the body portion 2710. The second interior cavity portion 2940 may have a volume that is between about 5% and about 35% of the volume of the body portion 2710. The second interior cavity portion 2940 may have a volume that is between about 5% and about 25% of the volume of the body portion 2710. The second interior cavity portion 2940 may have a volume that is between about 5% and about 10% of the volume of the body portion 2710. The apparatus, methods, and articles of manufacture described herein are not limited in this regard.

In one example, the second interior cavity portion 2940 may be unfilled (i.e., empty space). Alternatively, the second interior cavity portion 2940 may be partially or entirely filled with a filler material that is an elastic polymer or elastomer material and/or other suitable types of materials to

absorb shock, isolate vibration, dampen noise and/or move the center of gravity of the golf club head 2700 lower and farther back. A bonding portion (not show) similar to any of the bonding portions described herein may be used to bond the filler material to all or portions of the inner walls of the second interior cavity 2940. The second interior cavity portion 2940 may be filled from any opening on the body portion 2710 that may be closed after the second interior cavity portion 2940 is filled with the filler material. For example, any one or more of the weight ports 2840 may be connected to the second interior cavity portion 2940. Accordingly, the second interior cavity portion 2940 may be filled with the filler material from the one or more connected weight ports 2840. The filler material may be similar to any of the elastic polymer materials or filler materials described herein. The apparatus, methods, and articles of manufacture described herein are not limited in this regard.

In the example of FIGS. 31-36, a golf club head 3100 may include a body portion 3110, which may include a top portion 3130, a bottom portion 3140, a toe portion 3150, a heel portion 3160, a front portion 3170, and a rear portion 3180. The top portion 3130 may include a crown portion 3132 that may be constructed from the same or different materials as all or portions of the body portion 3110. For example, as shown in FIG. 36, the crown portion 3132 may be constructed from a different material and attached to the top portion 3130. In one example, the crown portion 3132 may be constructed from any material such as composite materials. In another example, the crown portion 3132 may be constructed from one or more layers including composite materials and one or more layers including an elastic polymer material. The apparatus, methods, and articles of manufacture described herein are not limited in this regard.

The bottom portion 3140 may include a skirt portion 3190 defined as a side portion of the golf club head 3100 between the top portion 3130 and the bottom portion 3140 excluding the front portion 3170 and extending across a periphery of the golf club head 3100 from the toe portion 3150, around the rear portion 3180, and to the heel portion 3160. The front portion 3170 may include a face portion 3175 to engage a golf ball (not shown). The body portion 3110 may also include a hosel portion 3165 to receive a shaft (not shown). Alternatively, the body portion 3110 may include a bore instead of the hosel portion 3165. For example, the body portion 3110 may be made partially or entirely of an aluminum-based material, a magnesium-type material, a steel-based material, a titanium-based material, any combination thereof, or any other suitable material. In another example the body portion 3110 may be made partially or entirely of a non-metal material such as a ceramic material, a composite material, any combination thereof, or any other suitable material. The apparatus, methods, and articles of manufacture described herein are not limited in this regard.

The golf club head 3100 may have a club head volume greater than or equal to 300 cubic centimeters (cm³ or cc). In one example, the golf club head 3100 may be about 540 cc. Alternatively, the golf club head 3100 may have a club head volume less than or equal to 300 cc. In particular, the golf club head 3100 may have a club head volume between 100 cc and 200 cc. The club head volume of the golf club head 3100 may be determined by using the weighted water displacement method (i.e., Archimedes Principle). For example, procedures defined by golf standard organizations and/or governing bodies such as the United States Golf Association (USGA) and/or the Royal and Ancient Golf Club of St. Andrews (R&A) may be used for measuring the club head volume of the golf club head 3100. Although

FIGS. 31-36 may depict a particular type of club head (e.g., a driver-type club head), the apparatus, methods, and articles of manufacture described herein may be applicable to other types of club head (e.g., a fairway wood-type club head, a hybrid-type club head, an iron-type club head, a putter-type club head, etc.). The apparatus, methods, and articles of manufacture described herein are not limited in this regard.

The bottom portion 3140 may include a plurality of weight portions 3220, one of which is shown as weight portion 3323 and a plurality of weight ports 3240, which are generally shown as weight ports 3441, 3442, 3444, and 3445. Each of the weight ports 3240 may receive one of the weight portions 3220. The weight portions 3220, the weight ports 3240, the mass of each weight portion 3220, the mass distribution of the weight portions 3220 on the body portion 3110, distances between the weight ports 3240, the materials of construction of the weight portions 3220, the dimensions of the weight portions 3220, the shapes of the weight portions 3220, and/or any other physical properties of any of the weight portions 3220 and the weight ports 3240 may be similar in many respects to any of the weight portions and weight ports described herein. The apparatus, methods, and articles of manufacture described herein are not limited in this regard.

The weight ports 3240 may be arranged on the body portion 3110 in any configuration. In one example, the weight ports 3240 may generally extend between the toe portion 3150 and the heel portion 3160 at a location between the front portion 3170 and the rear portion 3180. In the example of FIGS. 31-36, weight ports 3441, 3442, 3444 and 3445 extend in a direction from the toe portion 3150 to the heel portion 3160 proximate to the rear portion 3180 and may generally follow the contour or curvature of the rear portion 3180. The configuration of the plurality of weight ports 3240 may be similar to any one or a combination of the golf club heads described herein. In another example, the plurality of weight ports 3240 may extend between the toe portion 3150 and the heel portion 3160 at a maximum toe-to-heel weight port distance, which may be between about 20% and more or less than about 80% of the maximum toe-to-heel distance of the golf club head 3100. In yet another example, the plurality of weight ports 3240 may extend along a curve that is concave relative to the front portion 3170. In yet another example, the plurality of weight ports 3240 may extend along a curve that is concave relative to the rear portion 3180. In yet another example, the plurality of weight ports 3240 may be closer to the front portion 3170 than the rear portion 3180. In yet another example, the plurality of weight ports 3240 may be closer to the rear portion 3180 than the front portion 3170. The apparatus, methods, and articles of manufacture described herein are not limited in this regard.

In one example, the weight portions of the plurality of weight portions 3220 may have the same mass. In one example, the weight portions of the plurality of weight portions 3220 may have different masses. In one example, the plurality of weight portions 3220 may include a first set of weight portions (not shown) associated with a first mass and a second set of weight portions (not shown) associated with a second mass. In one example, the plurality of weight portions 3220 may be associated with a plurality of sets of masses. Accordingly, the overall weight, swing weight, and/or the weight distribution of the body portion 3110 may be configured to any overall weight, swing weight, and/or any type of weight distribution such as to a toe biased weight distribution, a heel biased weight distribution, a front biased weight distribution, a rear biased weight distribution or

various combinations thereof. Thus, the golf club head 3100 may accommodate any individual having any type of golf swing. In one example, the weight distribution of the body portion 3110 may be configured similar to the examples described herein. The apparatus, methods, and articles of manufacture described herein are not limited in this regard.

In one example, the body portion 3110 may include a first groove 3310 and a second groove 3320 on the bottom portion 3140. The first groove 3310 may be located closer to the front portion 3170 than the rear portion 3180. The second groove 3320 may be located closer to the rear portion 3180 than the front portion 3170. The grooves 3310 and 3320 may structurally support the bottom portion 3140 when the face portion 3175 strikes a golf ball (not shown). The grooves 3310 and 3320 may extend in any direction and in any configuration. For example, as shown in FIG. 32, the first groove 3310 has a first portion 3312 that may extend in a direction from the toe portion 3150 to the heel portion 3160. In one example, the first portion 3312 may be generally parallel to the face portion 3175. The first groove 3310 may include a second portion 3314 proximate to the toe portion 3150 that extends from the first portion 3312 toward the toe portion 3150 and the rear portion 3180. The first groove 3310 may also include a third portion 3316 proximate to the heel portion 3160 that extends from the first portion 3312 toward the heel portion 3160 and the rear portion 3180. The second groove 3320 may be similar in configuration to the first groove 3310. For example, as shown in FIG. 32, the second groove 3320 has a first portion 3322 that may extend in a direction from the toe portion 3150 to the heel portion 3160. In one example, the first portion 3322 may be generally parallel to the face portion 3175. The second groove 3320 may include a second portion 3324 proximate to the toe portion 3150 that extends from the first portion 3322 toward the toe portion 3150 and the rear portion 3180. The second groove 3320 may also include a third portion 3326 proximate to the heel portion 3160 that extends from the first portion 3322 toward the heel portion 3160 and the rear portion 3180. The shape of the grooves 3310 and 3320 may provide structural support for the body portion 3110 and further may provide dissipation and/or distribution of the forces exerted on the body portion 3110 during impact with a golf ball. For example, the grooves 3310 and 3320 may stiffen the bottom portion 3140 for structural support and/or to provide optimal vibration, dampening and/or noise characteristics for the golf club head 3100. In another example, the first groove 3310 and the second groove 3320 may dissipate and/or distribute the impact forces on the body portion 3110 throughout the body portion 3110 via the first groove portions 3312 and 3322, the second groove portions 3314 and 3324, and the third groove portions 3316 and 3326, respectively. The second groove portions 3314 and 3324 may dissipate and/or distribute the impact forces exerted on the bottom portion 3140 from the first groove portions 3312 and 3322, respectively, toward the toe portion 3150 and the rear portion 3180. In another example, the third groove portions 3316 and 3326 may dissipate and/or distribute the impact forces exerted on the bottom portion 3140 from the first groove portions 3312 and 3322, respectively, toward the heel portion 3160 and the rear portion 3180. Alternatively, the first groove 3310 and the second groove 3320 may have different configurations. The first groove 3310 and the second groove 3320 may have any depth, length, width and cross-sectional configuration. Each of the first groove 3310 and the second groove 3320 may extend between the toe portion 3150 and the heel portion 3160 between more than about 50% and less than about 90% of the maximum

toe-to-heel distance of the golf club head **3100**. Alternatively, each of the first groove **3310** and the second groove **3320** may extend between the toe portion **3150** and the heel portion **3160** between less than about 50% and more than about 90% of the maximum toe-to-heel distance of the golf club head **3100**. The grooves **3310** and **3320** may have a configuration similar to any of the grooves described herein. The apparatus, methods, and articles of manufacture described herein are not limited in this regard.

In one example, the weight ports **3441** and **3442** may be located on the bottom portion **3140** proximate to the toe portion **3150** and between the first groove **3310** and the second groove **3320**. The weight ports **3444** and **3445** may be located on the bottom portion **3140** proximate to the heel portion **3160** and between the first groove **3310** and the second groove **3320**. In one example, the distance between some or all of the adjacent weight ports of the plurality of weight ports **3440** may be less than or equal to a port diameter of any of the two adjacent weight ports. In another example, the distance between some or all of the adjacent weight ports of the weight ports may be greater than a port diameter of any of the two adjacent weight ports. The apparatus, methods, and articles of manufacture described herein are not limited in this regard.

The body portion **3110** may be a hollow body having one or more interior cavity portions. For example, as shown in FIG. **36**, the body portion **3110** may include a first interior cavity portion **3340** and a second interior cavity portion **3350**. The second interior cavity portion **3350** may be considered to be a part of the total volume of the body portion **3110**. The second interior cavity portion **3350** may be located on the bottom portion **3140** aft of the second groove **3320**. The second interior cavity portion **3350** may have any shape, configuration, length and/or width. In one example, as shown in FIG. **32**, the second interior cavity portion **3350** may have a shape that is generally similar to the shape of the portion of the bottom portion **3140** that is between the second groove **3320** and the rear portion **3180**. For example, as shown in FIG. **36**, the second interior cavity portion **3350** may be defined by a recess in the bottom portion **3140** proximate to the rear portion **3180** that may be covered with a bottom cover portion **3352**. The bottom cover portion **3352** may be connected and/or attached to the body portion **3110** by any fastening mechanism or method to partially or fully cover the second interior cavity portion **3350**. For example, as shown in FIG. **36**, the body portion **3110** may include a threaded bore **3112** between the recess defining the second interior cavity portion **3350** and the first interior cavity portion **3340**. The bottom cover portion **3352** may also include a bore **3354** that may be aligned with the threaded bore **3112** when the bottom cover portion **3352** is placed over the second interior cavity portion **3350**. A fastener **3356** may be inserted through the bore **3354** and threaded into the threaded bore **3112** to fasten the bottom cover portion **3352** to the body portion **3110**.

The bottom cover portion **3352** may include a recessed portion **3362** that is configured to fully receive the head portion **3370** of the fastener **3356** so that the head portion **3370** of the fastener **3356** does not protrude outward from the bottom portion **3140**. In one example, the recessed portion **3362** of the bottom cover portion **3352** may be similar in many respects to any of the weight ports of the plurality of weight ports **3440**. Accordingly, the fastener **3356** may be the weight portion **3423** of the plurality of weight portions **3420**, by which the bottom cover portion **3352** may be fastened to the body portion **3110**. Alternatively, the recessed portion **3362** and the fastener **3356** may

not be similar to any of the weight ports **3440** and/or any of the weight portions **3420**, respectively. The apparatus, methods, and articles of manufacture described herein are not limited in this regard.

In one example, the second interior cavity portion **3350** may be unfilled (i.e., empty space). Alternatively, the second interior cavity portion **3350** may be partially or entirely filled with an elastic polymer or elastomer material and/or other suitable types of materials to absorb shock, isolate vibration, and/or dampen noise. The material by which the second interior cavity portion **3350** may be filled may be similar to any of the elastic polymer materials described herein. Accordingly, a detailed description of the elastic polymer material by which the interior cavity portion **3350** may be filled is not provided. The apparatus, methods, and articles of manufacture described herein are not limited in this regard.

The second interior cavity portion **3350** may be filled with an elastic polymer or an elastomer material by injection molding. Alternatively, for example, as shown in FIG. **36**, the golf club head **3100** may include an insert **3380** constructed from an elastic polymer or an elastomer material such as any of the materials described herein. The insert **3380** may have a shape corresponding to the shape of the second interior cavity portion **3350** so as to fill the second interior cavity portion **3350**. The insert **3380** may include a recess portion **3382** that is configured to receive the recessed portion **3362** of the bottom cover portion **3352** so that the head portion **3370** of the fastener **3356** does not protrude outward from the bottom portion **3140** as described herein. For example, as shown in FIG. **34**, the bottom cover portion **3352** may not completely cover the second interior cavity portion **3350** such that portions of the insert **3380** may be exposed on the bottom portion **3140**. Accordingly, as shown in FIGS. **32-34** and **36**, the insert **3380** may be partially visible from the bottom portion **3140**. Alternatively, the bottom cover portion **3352** may completely cover the second interior cavity portion **3350**. The insert **3380** may provide reduced vibration, dampening and/or optimal noise characteristics for the golf club head **3100** when striking a golf ball. The insert **3380** may be interchangeable with other inserts having different elasticity and/or stiffness characteristics (e.g., made from different materials) to allow an individual to adjust the vibration, dampening and noise characteristics of the golf club head **3100**. The apparatus, methods, and articles of manufacture described herein are not limited in this regard.

The terms “and” and “or” may have both conjunctive and disjunctive meanings. The terms “a” and “an” are defined as one or more unless this disclosure indicates otherwise. The term “coupled” and any variation thereof refer to directly or indirectly connecting two or more elements chemically, mechanically, and/or otherwise. The phrase “removably connected” is defined such that two elements that are “removably connected” may be separated from each other without breaking or destroying the utility of either element.

The term “substantially” when used to describe a characteristic, parameter, property, or value of an element may represent deviations or variations that do not diminish the characteristic, parameter, property, or value that the element may be intended to provide. Deviations or variations in a characteristic, parameter, property, or value of an element may be based on, for example, tolerances, measurement errors, measurement accuracy limitations and other factors. The term “proximate” is synonymous with terms such as

“adjacent,” “close,” “immediate,” “nearby”, “neighboring”, etc., and such terms may be used interchangeably as appearing in this disclosure.

The apparatus, methods, and articles of manufacture described herein may be implemented in a variety of 5 embodiments, and the foregoing description of some of these embodiments does not necessarily represent a complete description of all possible embodiments. Instead, the description of the drawings, and the drawings themselves, disclose at least one embodiment, and may disclose alterna- 10 tive embodiments.

As the rules of golf may change from time to time (e.g., new regulations may be adopted or old rules may be eliminated or modified by golf standard organizations and/or governing bodies such as the USGA, the R&A, etc.), golf 15 equipment related to the apparatus, methods, and articles of manufacture described herein may be conforming or non-conforming to the rules of golf at any particular time. Accordingly, golf equipment related to the apparatus, meth- 20 ods, and articles of manufacture described herein may be advertised, offered for sale, and/or sold as conforming or non-conforming golf equipment. The apparatus, methods, and articles of manufacture described herein are not limited in this regard.

Further, while the above examples may be described with 25 respect to golf clubs, the apparatus, methods and articles of manufacture described herein may be applicable to other suitable types of sports equipment such as a fishing pole, a hockey stick, a ski pole, a tennis racket, etc.

Although certain example apparatus, methods, and 30 articles of manufacture have been described herein, the scope of coverage of this disclosure is not limited thereto. On the contrary, this disclosure covers all apparatus, methods, and articles of articles of manufacture fairly falling within the scope of the appended claims either literally or 35 under the doctrine of equivalents.

What is claimed is:

1. A golf club head comprising:

a body portion comprising a top portion, a bottom portion, 40 a toe portion, a heel portion, a front portion, and a rear portion;

a face portion attached to the front portion;

a first groove on the bottom portion, the first groove including:

a first groove portion extending in a direction from the 45 toe portion to the heel portion, the first groove portion generally parallel to the face portion;

a second groove portion proximate the toe portion and extending from the first groove portion toward the 50 toe portion and the rear portion; and

a third groove portion proximate the heel portion and extending from the first groove portion toward the heel portion and the rear portion; and

a second groove on the bottom portion, the second groove 55 including:

a first groove portion extending in a direction from the toe portion to the heel portion, the first groove portion generally parallel to the face portion;

a second groove portion proximate the toe portion and extending from the first groove portion toward the 60 toe portion and the rear portion; and

a third groove portion proximate the heel portion and extending from the first groove portion toward the heel portion and the rear portion,

wherein the first groove is located closer to the front 65 portion than the rear portion,

wherein the second groove is located closer to the rear portion than the front portion, and wherein the first groove is greater in length than the second groove.

2. A golf club head as defined in claim **1**, wherein the first groove extends between the toe portion and the heel portion between more than about 50% and less than about 90% of a maximum toe-to-heel distance of the golf club head.

3. A golf club head as defined in claim **1**, wherein the first groove extends a distance between the toe portion and the heel portion, and wherein the distance is greater than or equal to 50% of a maximum toe-to-heel distance of the golf club head.

4. A golf club head as defined in claim **1**, wherein the second groove extends between the toe portion and the heel portion between more than about 50% and less than about 90% of a maximum toe-to-heel distance of the golf club head.

5. A golf club head as defined in claim **1**, wherein the second groove extends a distance between the toe portion and the heel portion, and wherein the distance is greater than or equal to 50% of a maximum toe-to-heel distance of the golf club head.

6. A golf club head as defined in claim **1**, further comprising a first interior cavity portion within the body portion and a second interior cavity portion defined by a recess in the bottom portion, the second interior cavity portion having a shape that complements a shape of the bottom portion that is between the second groove and the rear portion.

7. A golf club head as defined in claim **1**, further comprising a bottom cover portion attached to the body portion and located between the second groove and the rear portion, the bottom cover portion covering an interior cavity portion comprising an interchangeable insert.

8. A golf club head comprising:

a body portion comprising a top portion, a bottom portion, a toe portion, a heel portion, a front portion, and a rear portion;

a first interior cavity portion within the body portion;

a second interior cavity portion defined by a recessed exterior surface of the bottom portion, the second interior cavity portion comprising an insert;

a bottom cover portion at least partially covering the second interior cavity portion;

a first groove on the bottom portion having a length extending between the toe portion and the heel portion; and

a second groove on the bottom portion having a length extending between the toe portion and heel portion, wherein the second groove is located aft of the first groove,

wherein the second interior cavity portion is located aft of the second groove, and wherein the first groove is greater in length than the second groove.

9. A golf club head as defined in claim **8**, wherein the insert comprises an elastic polymer or elastomer material.

10. A golf club head as defined in claim **8**, wherein the insert is shaped to fill the second interior cavity portion.

11. A golf club head as defined in claim **8**, further comprising a fastener securing the bottom cover portion to the body portion, wherein the bottom cover portion and the fastener together retain the insert in the second interior cavity portion.

12. A golf club head as defined in claim **8**, wherein the insert is interchangeable with other inserts having at least one of different elasticity or stiffness characteristics.

31

13. A golf club head as defined in claim 8, wherein the insert is partially visible from the bottom portion.

14. A golf club head comprising:

a body portion comprising a top portion, a bottom portion, a toe portion, a heel portion, a front portion, and a rear portion;

a first groove on the bottom portion having a length extending between the toe portion and the heel portion; a second groove on the bottom portion having a length extending between the toe portion and heel portion; and

a plurality of weight ports located on the bottom portion between the first groove and the second groove; and a plurality of weight portions, each weight portion of the plurality of weight portions received in a weight port of

the plurality of weight ports,

wherein the first groove is located closer to the front portion than the rear portion,

wherein the second groove is located closer to the rear portion than the front portion,

wherein the first groove has a different length than the second groove, and

wherein the first groove has a different width than the second groove.

15. A golf club head as defined in claim 14, wherein the plurality of weight ports include a first pair of weight ports spaced apart at the toe portion and extending between the first groove and the second groove.

16. A golf club head as defined in claim 14, wherein the plurality of weight ports include a second pair of weight

32

ports spaced apart at the heel portion and extending between the first groove and the second groove.

17. A golf club head as defined in claim 14, further comprising a first interior cavity portion within the body portion, a second interior cavity portion aft of the second groove and filled with a filler material comprising an elastic polymer or an elastomer material, and a bottom cover portion completely covering the second interior cavity portion.

18. A golf club head as defined in claim 14, further comprising a first interior cavity portion within the body portion, a second interior cavity portion aft of the second groove and filled with a filler material comprising an elastic polymer or an elastomer material, and a bottom cover portion partially covering the second interior cavity portion such that the filler material is visible from the bottom portion.

19. A golf club head as defined in claim 14, wherein the first groove extends a distance between the toe portion and the heel portion, and wherein the distance is greater than or equal to 50% of a maximum toe-to-heel distance of the golf club head.

20. A golf club head as defined in claim 14, wherein the second groove extends a distance between the toe portion and the heel portion, and wherein the distance is greater than or equal to 50% of a maximum toe-to-heel distance of the golf club head.

* * * * *