



(51) International Patent Classification:

F21S 2/00 (2006.01) F21V 21/14 (2006.01)  
F16M 11/04 (2006.01) F16M 13/02 (2006.01)  
F21V 21/005 (2006.01)

(21) International Application Number:

PCT/IB2013/055414

(22) International Filing Date:

2 July 2013 (02.07.2013)

(25) Filing Language:

English

(26) Publication Language:

English

(30) Priority Data:

PCT/CN2012/078748 17 July 2012 (17.07.2012) CN

(71) Applicant: **KONINKLIJKE PHILIPS N.V.** [NL/NL];  
High Tech Campus 5, NL-5656 AE Eindhoven (NL).

(72) Inventors: **LI, Gang**; c/o High Tech Campus Building 5,  
NL-5656 AE Eindhoven (NL). **LIN, Lihua**; c/o High Tech  
Campus Building 5, NL-5656AE Eindhoven (NL).

(74) Agents: **Van EEUWIJK, Alexander** et al.; High Tech  
Campus, Building 5, NL-5656 AE Eindhoven (NL).

(81) Designated States (unless otherwise indicated, for every  
kind of national protection available): AE, AG, AL, AM,  
AO, AT, AU, AZ, BA, BB, BG, BH, BN, BR, BW, BY,  
BZ, CA, CH, CL, CN, CO, CR, CU, CZ, DE, DK, DM,

DO, DZ, EC, EE, EG, ES, FI, GB, GD, GE, GH, GM, GT,  
HN, HR, HU, ID, IL, IN, IS, JP, KE, KG, KN, KP, KR,  
KZ, LA, LC, LK, LR, LS, LT, LU, LY, MA, MD, ME,  
MG, MK, MN, MW, MX, MY, MZ, NA, NG, NI, NO, NZ,  
OM, PA, PE, PG, PH, PL, PT, QA, RO, RS, RU, RW, SC,  
SD, SE, SG, SK, SL, SM, ST, SV, SY, TH, TJ, TM, TN,  
TR, TT, TZ, UA, UG, US, UZ, VC, VN, ZA, ZM, ZW.

(84) Designated States (unless otherwise indicated, for every  
kind of regional protection available): ARIPO (BW, GH,  
GM, KE, LR, LS, MW, MZ, NA, RW, SD, SL, SZ, TZ,  
UG, ZM, ZW), Eurasian (AM, AZ, BY, KG, KZ, RU, TJ,  
TM), European (AL, AT, BE, BG, CH, CY, CZ, DE, DK,  
EE, ES, FI, FR, GB, GR, HR, HU, IE, IS, IT, LT, LU, LV,  
MC, MK, MT, NL, NO, PL, PT, RO, RS, SE, SI, SK, SM,  
TR), OAPI (BF, BJ, CF, CG, CI, CM, GA, GN, GQ, GW,  
KM, ML, MR, NE, SN, TD, TG).

Declarations under Rule 4.17:

— as to applicant's entitlement to apply for and be granted a  
patent (Rule 4.17(ii))

Published:

— with international search report (Art. 21(3))  
— before the expiration of the time limit for amending the  
claims and to be republished in the event of receipt of  
amendments (Rule 48.2(h))

(54) Title: FIXTURE FOR INTERCONNECTION OF LIGHTING DEVICES

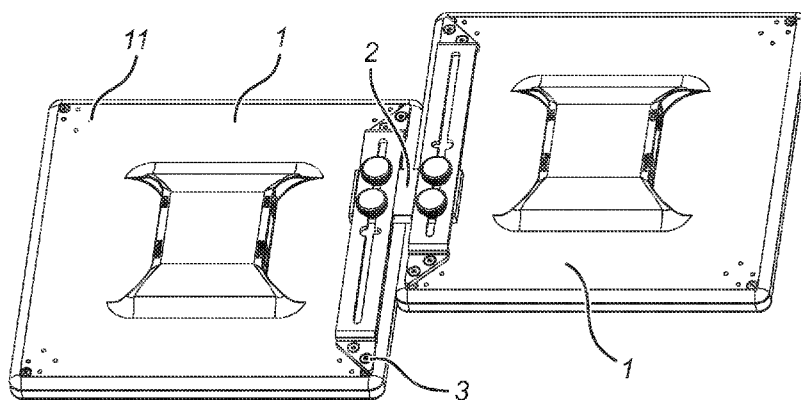

Fig. 1

(57) Abstract: The present invention is based on the understanding that if a changeless fixture is used to assemble lighting devices into a desired shape, a different fixture is needed for every desired shape. The present invention provides a fixture device (2) for attaching lighting devices (1) to each other. The fixture device comprises a slide bar arranged for attachment (3, 11) to a lighting device (1). The fixture device (2) further comprises a slide block (22). The fixture device (2) allows movement and locking of movement such that the first and the second lighting device (1) may be moved and locked from movement in the lateral direction, thereby allowing an adjustable interconnection of the first and the second lighting device (1).

## FIXTURE FOR INTECONNECTION OF LIGHTING DEVICES

5

## FIELD OF THE INVENTION

The present invention relates to the field of lighting devices and more specifically to the field of fixtures for interconnection of lighting devices.

## 10 BACKGROUND OF THE INVENTION

Lighting is an important aspect of any room. Flat panel lamps, especially LED flat panel lamps are usually designed as a lamp with just a simple lighting function. However, aesthetically lighting with a novel design is often desired for providing an attractive and unique indoor and outdoor environment. Thus, to satisfy people's living needs the lamps may need to embody both lighting and decorative function.

15

KR100732651 proposes a system for variable lighting design comprising two rail structures where multiple LED flat panel lamps may be inserted in between. This solution allows for different types of lamps, e.g. color and form, at least to some extent, to be placed beside each other in a row.

20

## SUMMARY OF THE INVENTION

It is an object of the present invention to provide a fixture for an adjustable interconnection of lighting devices and a lighting system that is inexpensive and provides a simple approach for interconnecting the lighting devices of the system in a flexible way.

25

The present invention is based on the understanding that if a changeless fixture is used to assemble lighting devices into a desired shape, a different fixture is needed for every desired shape. This may lead to high costs both for producers, e.g. manufacturing costs, storing costs etc., and for consumers. It would thus be desirable to have a more flexible way of interconnecting lighting devices.

30

According to a first aspect of the invention, this and other objects are achieved by a fixture device for attaching lighting devices to each other, comprising  
a first slide bar arranged for attachment to a first lighting device,  
a slide block coupled to a second lighting device and connected to the first slide bar, the slide block allowing movement and locking of movement of the first slide bar in a lateral direction of the slide block, respectively,

35

such that the first lighting device may be moved and locked from movement in the lateral direction relative the second lighting device, respectively.

This fixture device may allow for a flexible and simple way of interconnecting lighting devices. By allowing relative lateral movement between the first and the second lighting device, the number of possible ways of how two lighting devices may be interconnected to each other may be increased. In other words, the fixture setup is changeable which allows for an adjustable mechanical interconnection of lighting devices.

According to an embodiment of the present invention, the fixture device further comprising

a second slide bar arranged for attachment to the second lighting device,

wherein

the slide block is connecting the first and second slide bars, and allowing movement and locking of movement of the slide bars in a lateral direction of the slide block, respectively,

such that the second lighting device may be moved and locked from movement in the lateral direction relative the first lighting device, respectively.

An advantage of the present embodiment may be that the flexibility when interconnecting two lighting devices with the fixture device is increased since both lighting devices has a slide bar. Consequently, both the lighting devices may be further movable relative each other.

According to an embodiment of the present invention, the first and/or the second slide bar comprises an elongated slot, and the slide block comprises a fastener arranged in the elongated slot to allow the movement and locking of movement of the first and/or the second slide bar.

An advantage of the present embodiment may be that the user is guided by the fastener and the elongated slot when the relative position of the interconnected lighting devices is changed. A further advantage may be that the user is restricted from parting the lighting devices by mistake when the relative position of the interconnected lighting devices is changed.

According to an embodiment of the present invention, the fastener comprises a bolt and nut arrangement, wherein the bolt is attached to the slide bar, and wherein the locking of movement is accomplished by tightening of the bolt. An advantage of utilizing a bolt and nut arrangement may be that this is a well known standard way of accomplishing locking of movement and thus not requiring any special skills from a user handling the device. A further advantage may be that no special tools are needed when adjusting the relative position of two lighting devices using the present embodiment.

According to yet another embodiment, the first and/or the second slide bar further has an installation slot for suspending the fixture device. Consequently, the suspension of the fixture device in a ceiling or on a wall may be simplified.

According to yet another embodiment of the present invention, a maximum lateral movement of the first and/or the second slide bar is limited by the length of the elongated slot of the first and/or the second slide bar and the width of the slide block. This feature may prevent two lighting devices interconnected by the fixture device from being completely separated by mistake when adjusting the interconnection, e.g. by moving one lighting device too far relative to the other lighting device.

According to an embodiment of the present invention, the slide block has at least one lower-level section. The at least one lower-level section has the corresponding size of a slide bar such that the first and/or the second slide bar will match into the corresponding lower-level section of the slide block. An advantage of this embodiment may be that the user is guided when the relative position of the interconnected lighting devices is changed.

According to a second aspect of the present invention, the above mentioned objects have also been achieved by an adjustable lighting system having a fixture device according to the first aspect of the present invention, and a first and a second lighting device, wherein the first and the second lighting device are interconnected using the fixture device. The first and second lighting devices may be interconnected substantially within the same plane and the relative position of the first and second lighting device may be adjustable. This may provide a lighting system which utilize a small number of elements and permit a wide variety of lighting system designs. Thus, an inexpensive and simple approach for interconnecting lighting devices in a flexible way may be achieved.

According to a further embodiment of the present invention, the first and/or second lighting device has a slide bar connector for attaching the slide bar to a lighting device, wherein the slide bar connector comprises a bolt and nut arrangement, wherein the bolt is attached to the slide bar, and wherein the attachment of the first and second lighting device to the corresponding slide bar is accomplished by tightening of the bolt.

An advantage of utilizing a bolt and nut arrangement may be that this is a well known standard way of attaching a device to another device and thus not requiring any special skills from a user handling the device.

According to another embodiment of the present invention, the slide bar connector further comprises a pivot or hinge connection for attachment to the first and/or second lighting device. A lighting system including this feature may allow the lighting devices to be adjustable in more than one plane. By adapting the lighting system for such a foldable connection, a 3D configuration of the lighting devices may be achieved.

According to another embodiment of the present invention, the slide bar connector is arranged to attach the slide bar in a plurality of positions relative the lighting device. This may lead to more interconnection possibilities and thus a more flexible system.

The first and the second lighting device of the present invention may be a flat panel lighting device. The first and the second lighting device may also be an LED flat panel

lighting device. An advantage of using an LED flat panel lighting device may be that LED is an energy effective way of illuminating and thus require less power than other types of lighting devices.

5 According to a third aspect of the present invention, the above mentioned objects have also been achieved by using a fixture device according to the first aspect for interconnecting lighting devices to each other. The third aspect may generally have the same features and advantages as the first aspect.

It is noted that the invention relates to all possible combinations of features recited in the claims.

10

#### BRIEF DESCRIPTION OF THE DRAWINGS

This and other aspects of the present invention will now be described in more detail, with reference to the appended drawings showing embodiment(s) of the invention.

15 Fig. 1 illustrates a lighting system according to embodiments of the present invention;

Fig. 2 illustrates an exploded view of a lighting system according to embodiments;

Fig. 3 illustrates a perspective view of a fixture device according to embodiments;

20 Fig. 4 illustrates an exploded view of a fixture device according to embodiments;

Figs. 5 and 6 illustrate the adjustment process of a lighting system according to embodiments;

25 Figs. 7-8 and 9-10 illustrate different ways of interconnecting lighting devices according to embodiments.

As illustrated in the figures, the sizes of layers and regions are exaggerated for illustrative purposes and, thus, are provided to illustrate the general structures of embodiments of the present invention. Like reference numerals refer to like elements throughout.

#### 30 DETAILED DESCRIPTION

The present invention will now be described more fully hereinafter with reference to the accompanying drawings, in which embodiments of the invention are shown. This invention may, however, be embodied in many different forms and should not be construed as limited to the embodiments set forth herein; rather, these embodiments are provided for thoroughness and completeness, and fully convey the scope of the invention to the skilled person.

Throughout this detailed description, the fixture device is used for interconnecting flat panel lamps or similar, but this is merely an exemplary use of the fixture

device. Other types of lighting devices, such as a lamp with 3d structures, are equally possible.

Figs. 1 and 2 show the structure of embodiments of the present invention. The shown arrangement comprises a fixture device 2 and two flat panel lamps 1. Four groups of screw holes 11 are evenly disposed on the back of each flat panel lamp 1, and each group of screw holes 11 matches the countersunk holes of a slide bar 21. In this embodiment, one group of screw holes 11 is positioned in each of the corners of the flat panel lamp but this setup depends on design of the fixture device 2. The setup of screw holes 11 in the flat panel lamp 1 allows the slide bar to be fastened in a plurality of positions on the flat panel lamp, as will be shown in greater detail later in this application. The slide bars 21 may be of any suitable shape but in this embodiment they extend along the entire edge of the flat panel lamp 1 to which it is fastened. This may be advantageous for stability and flexibility reasons. The material of the slide bar and the slide block is preferably some kind of metal, such as aluminum, but plastic material or any other suitable material could also be used.

As shown in Figs. 2 and 3, countersunk holes 213 of the slide bar 21 are disposed to facilitate the slide bar 21 to be fastened to the flat panel lamp 1 by use of countersunk head screws 3. As seen in Fig 2, the counter sunk holes 213 are located on a triangle shaped surface to allow for a further slide bar to be fastened to the remaining two screw holes 11 not used by the current slide bars 21, for example the two lower left screw holes in the lower right corner of the left flat panel lamp in Fig 2. An elongated slot 211 of the slide bar 21 is disposed to enable the sliding of a slide block 22. An installation slot 212 of the slide bar 21 is disposed to facilitate the installing of the interconnected flat panel lamps system of the present invention. The installation slot is positioned at the center of the fixture device; this allows the system to be balanced when installed on a wall or hung from a ceiling.

Now referring to Figs. 3 and 4, the fixture device 2 comprises two slide bars 21, a slide block 22 and four sets of fasteners 23 arranged in the elongated slots 211 to allow the movement and locking of movement of the slide bars 21. Each set of fasteners 23 further comprises a flat washer 233, a spring washer 232 and a knob lock screw 231. Depending on the system, it may be sufficient with only one fastener 23 arranged in the elongated slot of a slide bar, but two fasteners may provide more stability to the system. The setup of the fastener above is only one exemplary setup out of many. The fastener 23 could also comprise a snap locking or any other suitable fastening setup. The knob lock screw may be replaced with any other screw, the advantage of using a screw with a head such as the knob lock screw or a cap screw is that no extra tools, such as a screw driver, may be needed if a user wants to adjust the interconnection of two flat panel lamps. The countersunk holes 213 are located on a surface which is lower relative to the rest of the slide bar 21. This facilitates the possibility to change the position of the slide block 22 and thus the relative position of the two slide bars 21

without removing the slide bar, e.g. unscrewing it, from the flat panel lamp to which it is fastened.

As shown in Fig. 4, a sunken model slot 221 of the slide block 22 restricts the lateral movements of the slide bar 21 after assembling, and the slide block 22 can perform longitudinal relative sliding when unscrewing the knob lock screws 231 which are locked to screw holes 222 on the bottom of the sunken model slot 221.

Figs. 5 and 6 show an adjusting process of a relative position along a connection side of the two interconnected flat panel lamps 1. After unscrewing the two knob lock screws 231, as illustrated in Fig. 5, to unlock the flat panel lamp, e.g. the right flat panel lamp in Figs 5 and 6, the interconnected flat panel lamp 1 is pushed relative to the second flat panel lamp, e.g. the left flat panel lamp in Figs 5 and 6, on the right side along the connection side of the two flat panel lamps 1. The pushing is stopped when the relative position of the interconnected flat panel lamps 1 reaches the desired position within a maximum scope allowed by the fixture device 2. The previously unscrewed knob lock screws 231 are tightened to lock the position of the adjusted flat panel lamp, and thus the relative position of the interconnected flat panel lamps 1 is changed. The maximum scope of the relative position adjustment of the interconnected flat panel lamps 1 depends on the length of the elongated slot 211 and the width of the slide block 22. In this embodiment, the elongated slot 211 is disposed substantially along the entire slide bar. An advantage of this is that the maximum scope is extended. The adjusting process described in this embodiment is simple to perform; no extra tools or training is needed.

Some exemplary interconnections of flat panel lamps 1 will now be described with reference to Figs 7, 8, 9 and 10.

As illustrated in the embodiment of Figs. 7 and 8, an oblique line style from a back view and a front view, respectively, of the lighting system of the present invention is obtained. This exemplary lighting system comprises four flat panel lamps 1, four fixture devices 2, an appropriate amount of countersunk head screws 3, and four extra slide bars 21; wherein the installation slot 212 of the four extra slide bars 21 facilitates to suspending the lighting system of the present embodiment in a desired position on a wall or in a ceiling. The advantage of using extra slide bars for suspending the lighting system is that no further parts need to be manufactured when producing the lighting system. This may lead to a cheaper manufacturing process and an easier setup of the system. The installation slot 212 is in this embodiment integrally formed in the slide bar 21, but other setups are equally possible. For example, an external hook or some other projecting device may be attached to the slide bar. An advantage of having such an integrally formed installation slot is that no extra protruding part is used for suspending the lighting system on a wall; thereby a flush design with the wall may be achieved. As illustrated in Figs 7 and 8, the slide bar 21 may be attached to a single

flat panel lamp 1 in a plurality of different positions. Three positions are shown in this setup, but four positions are possible.

As shown in the embodiment of Figs. 9 and 10, the present embodiment comprises five flat panel lamps 1, five fixture devices 2, an appropriate amount of  
5 countersunk head screws 3, and three extra slide bars 21. In particular illustrated in Fig. 9; two fixture devices 2 shares a slide bar 2. This possibility may lead to more options when interconnecting the flat panel lamps in a lighting system.

The person skilled in the art realizes that the present invention by no means is limited to the preferred embodiments described above. On the contrary, many modifications  
10 and variations are possible within the scope of the appended claims. For example, the slide bars of the fixture device may be fastened to the flat panel lamp by gluing or welding or it may also be an integrated part of the flat panel lamp.

Additionally, variations to the disclosed embodiments can be understood and effected by the skilled person in practicing the claimed invention, from a study of the  
15 drawings, the disclosure, and the appended claims. In the claims, the word "comprising" does not exclude other elements or steps, and the indefinite article "a" or "an" does not exclude a plurality. The mere fact that certain measures are recited in mutually different dependent claims does not indicate that a combination of these measured cannot be used to advantage.

## CLAIMS

1. A fixture device (2) for attaching lighting devices (1) to each other, comprising a first slide bar (21) arranged for attachment (3, 11) to a first lighting device (1),  
a slide block (22) coupled to a second lighting device (1) and connected to the first slide bar (21), the slide block allowing movement and locking of movement of the first slide bar (21) in a lateral direction of the slide block (22), respectively,  
such that the first lighting device (1) may be moved and locked from movement in the lateral direction relative the second lighting device (1), respectively.
2. The fixture device (2) of claim 1, further comprising a second slide bar arranged for attachment (3, 11) to the second lighting device (1), wherein  
the slide block connecting the first and second slide bars (21), and allowing movement and locking of movement of the slide bars (21) in a lateral direction of the slide block (22), respectively,  
such that the second lighting device (1) may be moved and locked from movement in the lateral direction relative the first lighting device (1), respectively.
3. The fixture device (2) of claim 1 or 2, wherein  
the first and/or the second slide bar (21) comprises an elongated slot (211), and the slide block (22) comprises a fastener (23, 231, 232, 233, 222) arranged in the elongated slot (211) to allow the movement and locking of movement of the first and/or the second slide bar (21).
4. The fixture device (2) of claim 3, wherein the fastener (23, 231, 232, 233, 222) comprises a bolt (231) and nut arrangement, wherein the bolt (231) is attached to the slide bar (21), and wherein the locking of movement is accomplished by tightening of the bolt (231).
5. The fixture device (2) of claim 1 or 2, wherein the first and/or the second slide bar (21) further has an installation slot (212) for suspending the fixture device (2).

6           The fixture device (2) of claim 3, wherein a maximum lateral movement of the first and/or the second slide bar (21) is limited by the length of the elongated slot (211) of the first and/or the second slide bar (21) and the width of the slide block (22).

5   7.           The fixture device (2) of claim 1 or 2, wherein  
the slide block (22) has at least one lower-level section (221),  
the at least one lower-level section (221) has a size corresponding to that of a  
slide bar (21), such that the first and/or the second slide bar (21) will match into the  
corresponding lower-level section (221) of the slide block.

10

8.           An adjustable lighting system having  
a fixture device (2) according to any one of claims 1 to 7,  
a first and a second lighting device (1), wherein  
the first and the second lighting device (1) are interconnected using the  
15 fixture device (2).

9           The adjustable lighting system according to claim 8, wherein the first and  
second lighting device (1) are interconnected substantially within the same plane and wherein  
the relative position of the first and second lighting device (1) is adjustable.

20

10.           The adjustable lighting system according to claim 8, wherein the first and/or  
second lighting device (1) has a slide bar connector (3, 11, 213) for attaching the slide bar  
(21) to a lighting device (1), wherein the slide bar connector (3, 11, 213) comprises a bolt (3)  
and nut arrangement, wherein the bolt (3) is attached to the slide bar (2), and wherein the  
25 attachment of the first and/or second lighting device (1) to the corresponding slide bar (2) is  
accomplished by tightening of the bolt.

11           The adjustable lighting system according to claim 10, wherein  
the slide bar connector (3, 11, 213) further comprises a pivot or hinge  
30 connection for attachment (3, 11) to the first and/or second lighting device (1).

12.           The adjustable lighting system according to claim 10, wherein the slide bar  
connector (3, 11, 213) is arranged to attach the slide bar in a plurality of positions relative the  
lighting device (1).

35

13.           The adjustable lighting system according to claim 8, wherein the first and the  
second lighting device (1) is a flat panel lighting device.

14. The adjustable lighting system according to claim 8, wherein the first and the second lighting device (1) is a LED flat panel lighting device.

15. Use of a fixture device (2) according to any of claims 1 to 7 for interconnecting  
5 lighting devices (1) to each other.

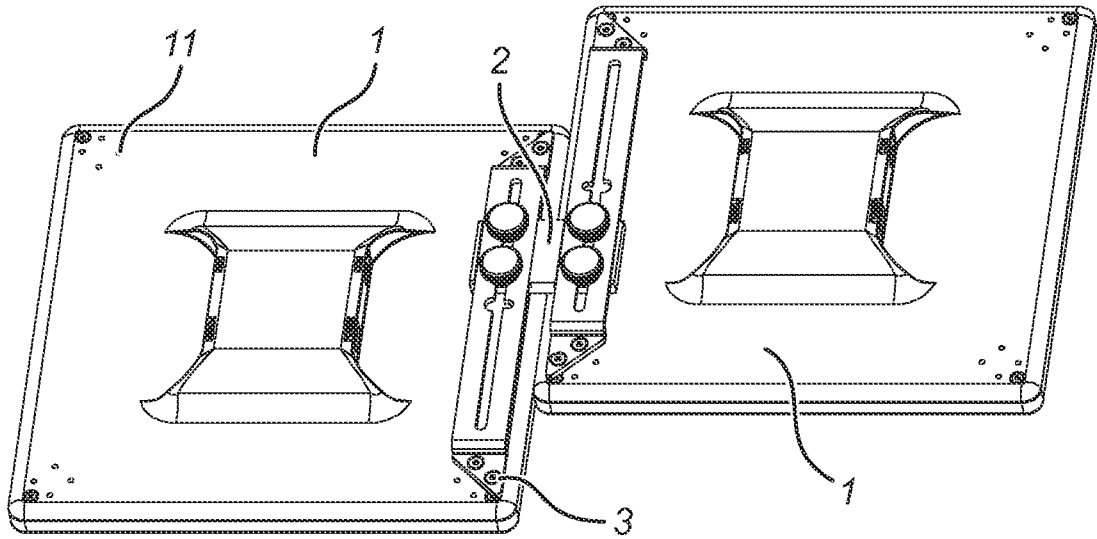

Fig. 1

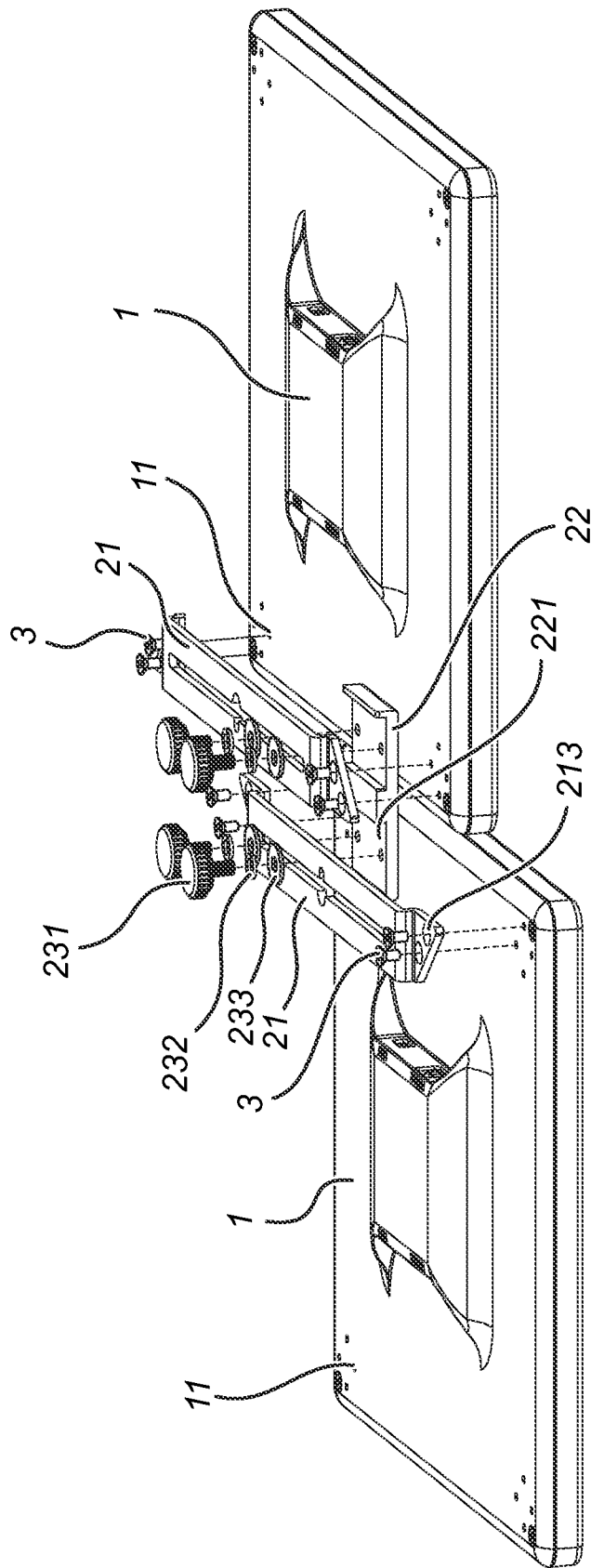

Fig. 2

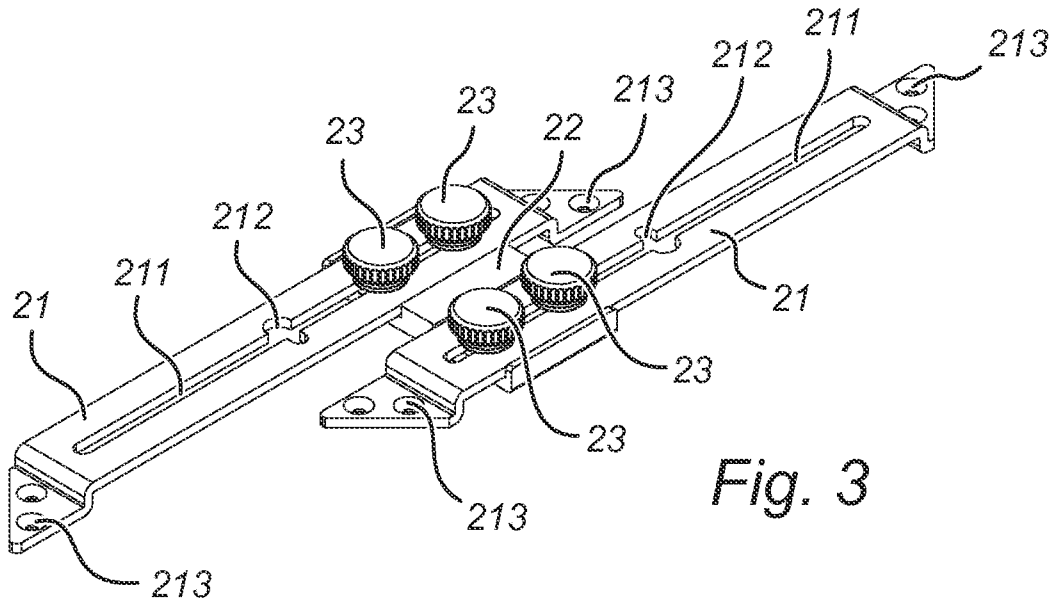

Fig. 3

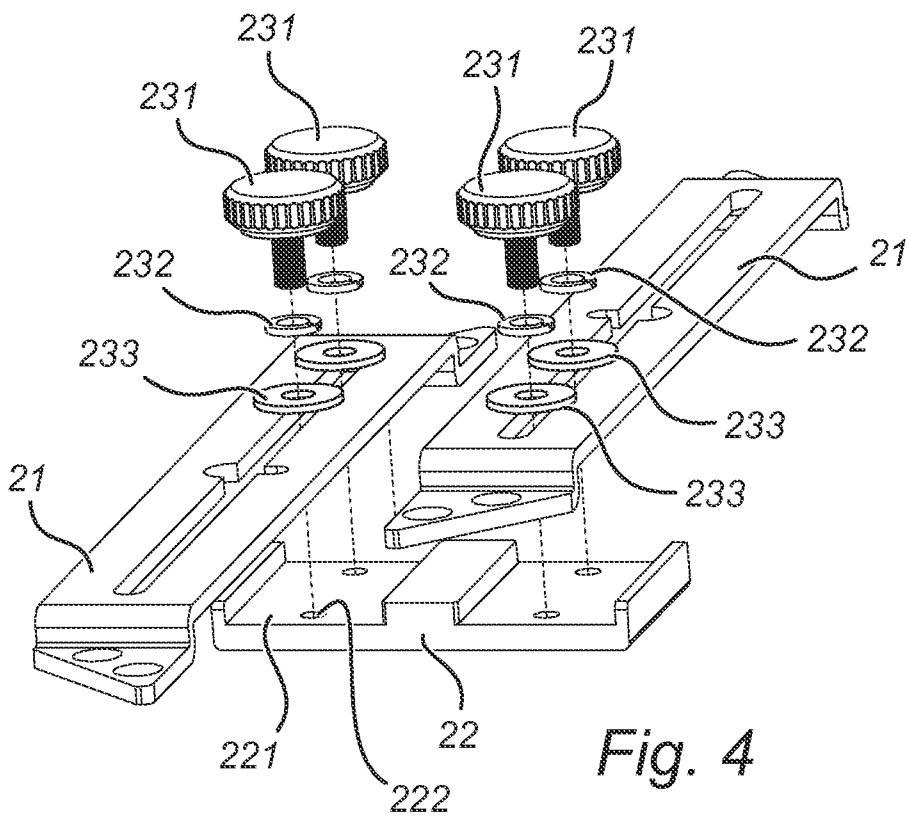

Fig. 4

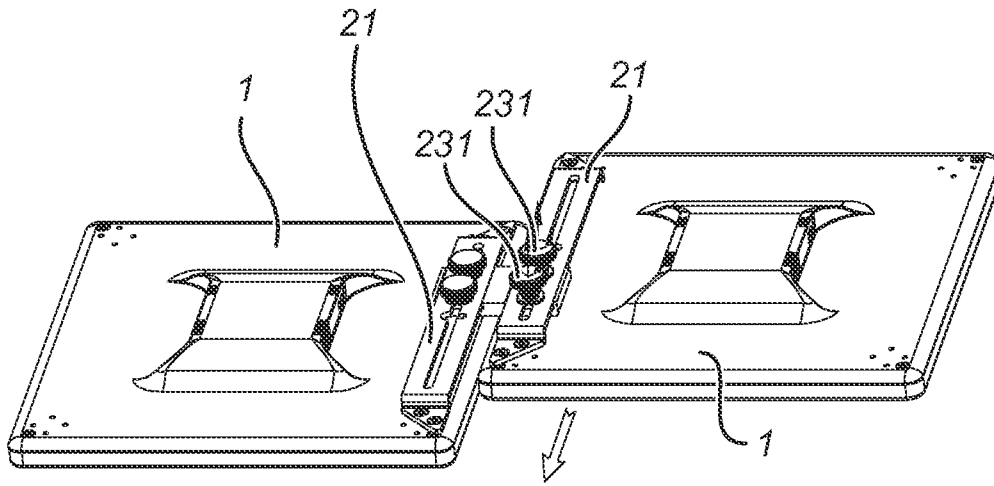

Fig. 5

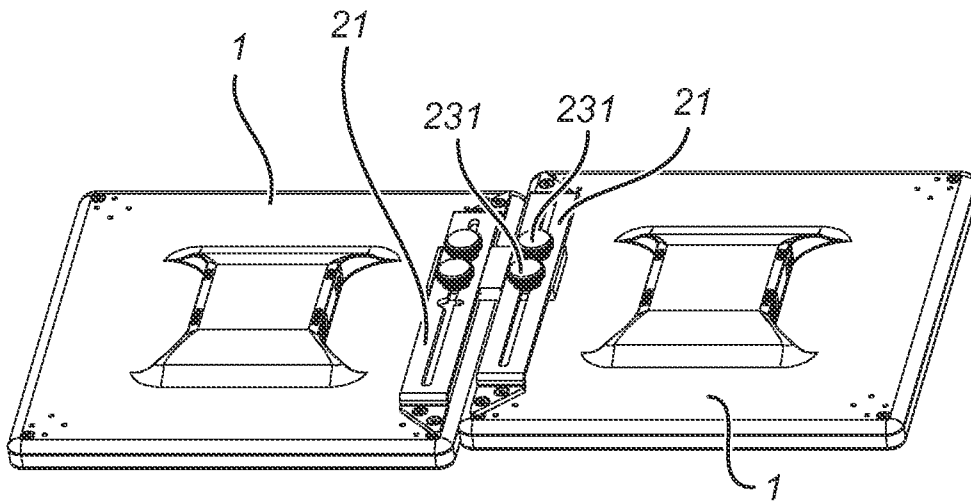

Fig. 6

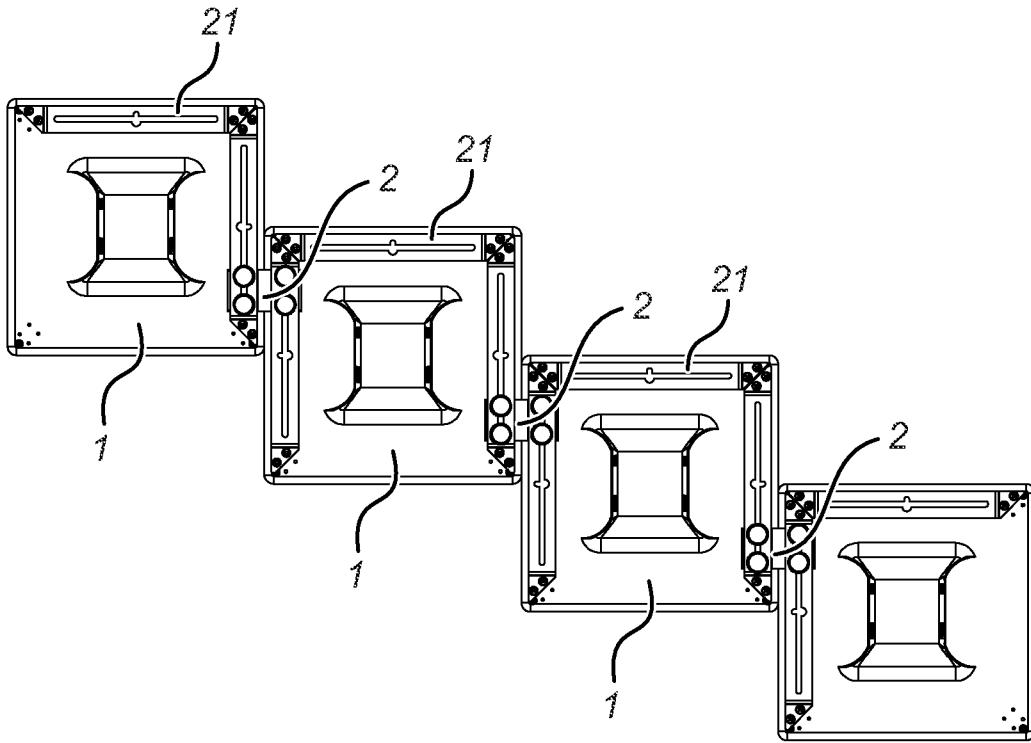

Fig. 7

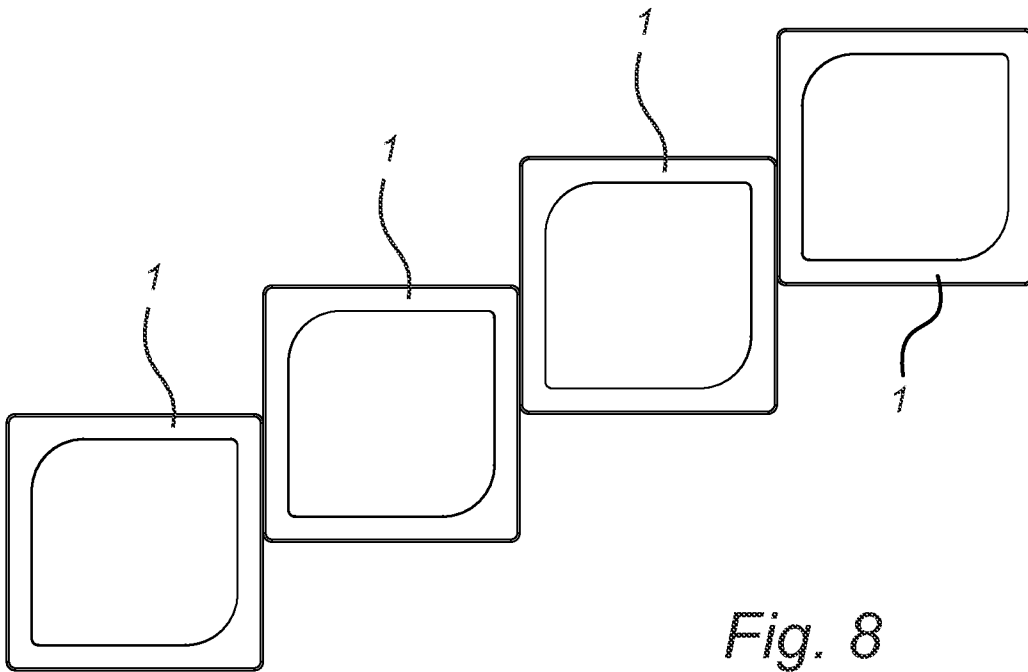

Fig. 8

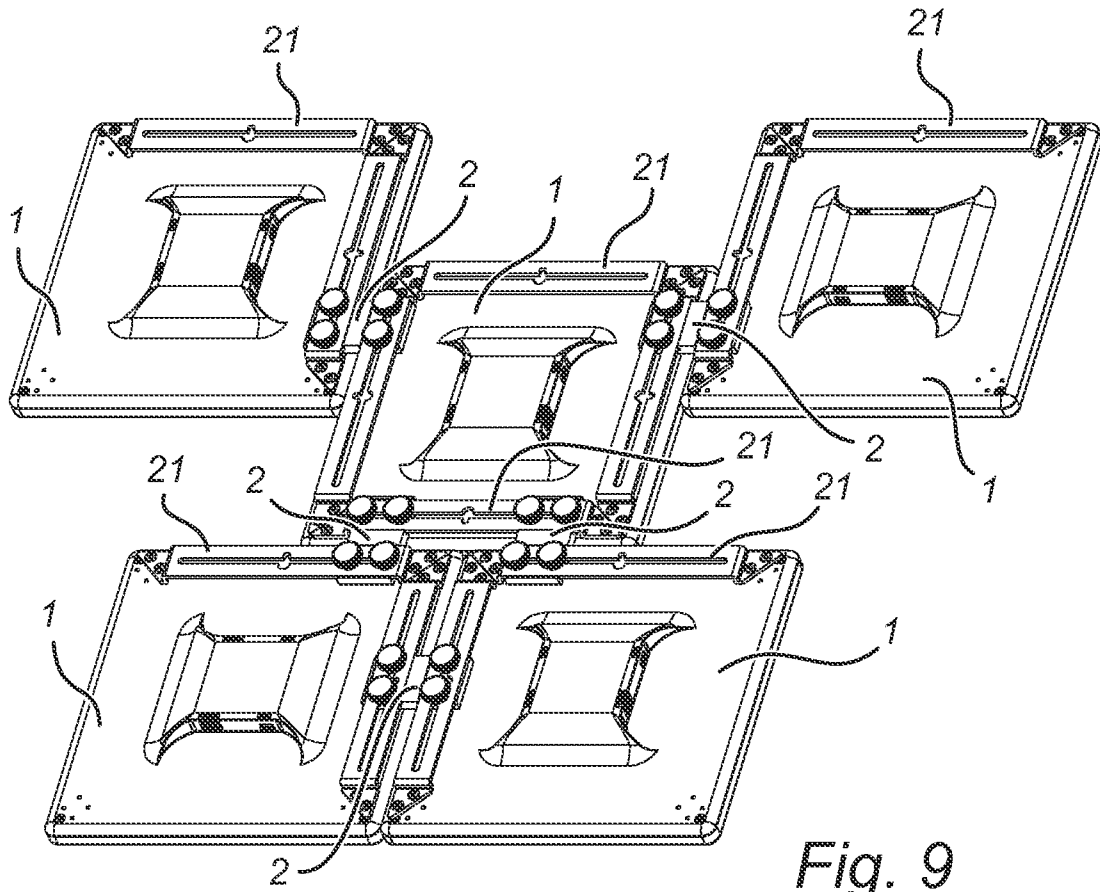
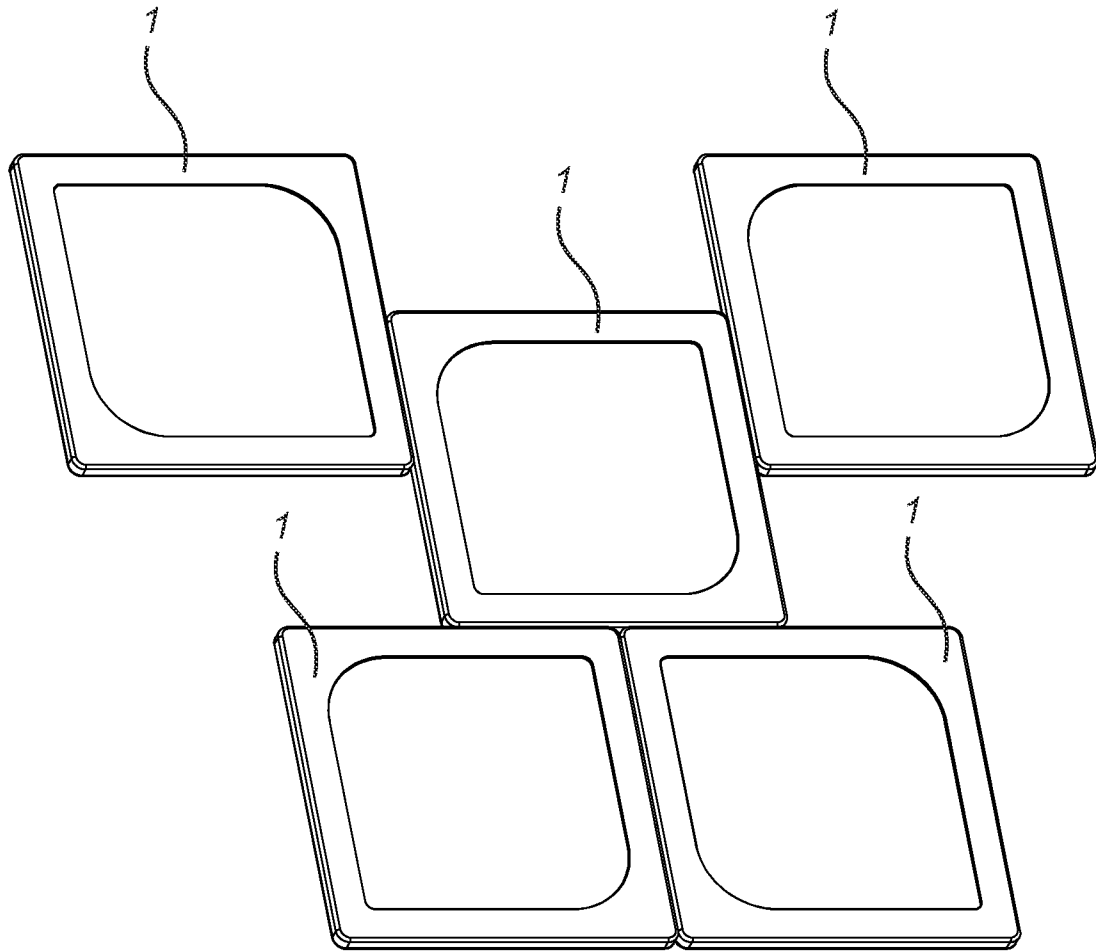

Fig. 9



*Fig. 10*

**INTERNATIONAL SEARCH REPORT**

International application No PCT/IB2013/055414
---

**A. CLASSIFICATION OF SUBJECT MATTER**  
 INV. F21S2/00 F16M11/04 F21V21/005 F21V21/14  
 ADD. F16M13/02

According to International Patent Classification (IPC) or to both national classification and IPC

**B. FIELDS SEARCHED**

Minimum documentation searched (classification system followed by classification symbols)  
 F21V F21S F16M

Documentation searched other than minimum documentation to the extent that such documents are included in the fields searched

Electronic data base consulted during the international search (name of data base and, where practicable, search terms used)  
 EPO-Internal, WPI Data

**C. DOCUMENTS CONSIDERED TO BE RELEVANT**

Category*	Citation of document, with indication, where appropriate, of the relevant passages	Relevant to claim No.
X	US 6 431 726 B1 (BARTON BINA M [US]) 13 August 2002 (2002-08-13)	1-4,6, 8-10, 12-15
A	column 2, line 32 - column 3, line 26; figures 1-5	5,7,11
A	----- EP 2 362 132 A2 (BENWIRTH LICHT E K [DE]) 31 August 2011 (2011-08-31) the whole document	1-15
A	----- DE 20 2011 000355 U1 (HUANG MING HSIEN [TW]) 9 June 2011 (2011-06-09) the whole document	1-15
	-----	

Further documents are listed in the continuation of Box C.       See patent family annex.

\* Special categories of cited documents :

"A" document defining the general state of the art which is not considered to be of particular relevance	"T" later document published after the international filing date or priority date and not in conflict with the application but cited to understand the principle or theory underlying the invention
"E" earlier application or patent but published on or after the international filing date	"X" document of particular relevance; the claimed invention cannot be considered novel or cannot be considered to involve an inventive step when the document is taken alone
"L" document which may throw doubts on priority claim(s) or which is cited to establish the publication date of another citation or other special reason (as specified)	"Y" document of particular relevance; the claimed invention cannot be considered to involve an inventive step when the document is combined with one or more other such documents, such combination being obvious to a person skilled in the art
"O" document referring to an oral disclosure, use, exhibition or other means	"&" document member of the same patent family
"P" document published prior to the international filing date but later than the priority date claimed	

Date of the actual completion of the international search  14 November 2013	Date of mailing of the international search report  21/11/2013
---	--

Name and mailing address of the ISA/ European Patent Office, P.B. 5818 Patentlaan 2 NL - 2280 HV Rijswijk Tel. (+31-70) 340-2040, Fax: (+31-70) 340-3016	Authorized officer  Menn, Patrick
--	---

# INTERNATIONAL SEARCH REPORT

Information on patent family members

International application No <b>PCT/IB2013/055414</b>
--

Patent document cited in search report	Publication date	Patent family member(s)	Publication date
US 6431726	B1	13-08-2002	NONE
-----			
EP 2362132	A2	31-08-2011	DE 102010008788 A1 EP 2362132 A2
-----			
DE 202011000355	U1	09-06-2011	DE 202011000355 U1 TW M396551 U US 2012056050 A1 US 2012318938 A1
-----			