



US00RE50485E

(19) **United States**
(12) **Reissued Patent**
Hoegerl et al.

(10) **Patent Number:** **US RE50,485 E**
(45) **Date of Reissued Patent:** **Jul. 8, 2025**

(54) **SEMICONDUCTOR MODULE WITH EXTERNAL POWER SENSOR**

(71) Applicant: **Infineon Technologies AG**, Neubiberg (DE)

(72) Inventors: **Juergen Hoegerl**, Regensburg (DE); **Leo Aichriedler**, Puch (AT); **Christian Schweikert**, Munich (DE); **Gerald Wriessnegger**, Villach (AT)

(73) Assignee: **Infineon Technologies AG**, Neubiberg (DE)

(56) **References Cited**
U.S. PATENT DOCUMENTS

5,936,402 A 8/1999 Schep et al.
5,963,028 A 10/1999 Engel et al.
(Continued)

FOREIGN PATENT DOCUMENTS

CN 1460184 A 12/2003
CN 102983766 A 3/2013
(Continued)

OTHER PUBLICATIONS

(21) Appl. No.: **17/704,811**
(22) Filed: **Mar. 25, 2022**

“Coreless Current Sensor for High Current Power Module”, U.S. Appl. No. 15/878,982, filed Jan. 24, 2018.
(Continued)

Related U.S. Patent Documents

Reissue of:
(64) Patent No.: **10,699,976**
Issued: **Jun. 30, 2020**
Appl. No.: **16/260,405**
Filed: **Jan. 29, 2019**

Primary Examiner — Minh Nguyen
(74) *Attorney, Agent, or Firm* — Murphy, Bilak & Homiller, PLLC

(51) **Int. Cl.**
H01L 23/31 (2006.01)
G01R 15/20 (2006.01)
(Continued)

(57) **ABSTRACT**

A semiconductor module includes a semiconductor die, a mold compound encasing the semiconductor die, a plurality of terminals electrically connected to the semiconductor die and protruding out of the mold compound, wherein a first one of the terminals has a constricted region covered by the mold compound, wherein the mold compound has a recess or an opening near the constricted region of the first terminal, and a coreless magnetic field sensor disposed in the recess or the opening of the mold compound and isolated from the first terminal by the mold compound. The coreless magnetic sensor is configured to generate a signal in response to a magnetic field produced by current flowing in the constricted region of the first terminal. The magnitude of the signal is proportional to the amount of current flowing in the constricted region of the first terminal. A method of manufacturing the module also is described.

(52) **U.S. Cl.**
CPC **H01L 23/3121** (2013.01); **G01R 15/207** (2013.01); **G01R 33/072** (2013.01);
(Continued)

(58) **Field of Classification Search**
CPC . H01L 23/3121; H01L 21/4817; H01L 25/16;
H01L 21/4871; H01L 23/3675;
(Continued)

32 Claims, 10 Drawing Sheets

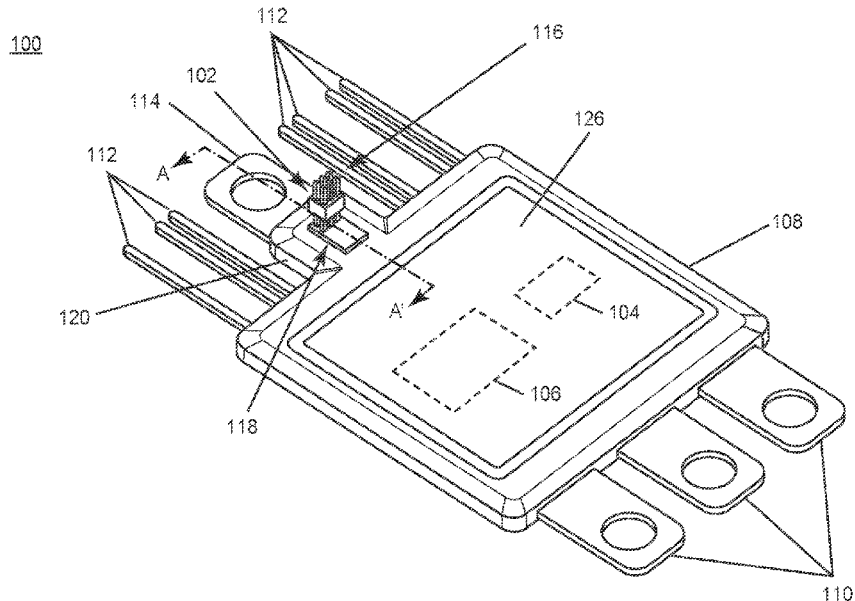

(51) Int. Cl.		9,564,423 B2	2/2017	Chen et al.	
G01R 33/00	(2006.01)	9,678,173 B2	6/2017	Castro Serrato	
G01R 33/07	(2006.01)	2004/0217451 A1	11/2004	Lee et al.	
G01R 33/09	(2006.01)	2006/0226826 A1	10/2006	Teppan	
H01L 21/48	(2006.01)	2007/0290337 A1	12/2007	Otremba et al.	
H01L 21/56	(2006.01)	2010/0301852 A1	12/2010	Teppan et al.	
H01L 21/66	(2006.01)	2011/0304327 A1	12/2011	Ausserlechner	
H01L 23/051	(2006.01)	2012/0267730 A1	10/2012	Renard et al.	
H01L 23/057	(2006.01)	2013/0058143 A1	3/2013	Tachibana	
H01L 23/367	(2006.01)	2013/0105961 A1	5/2013	Jones et al.	
H01L 23/373	(2006.01)	2013/0249544 A1	9/2013	Vig et al.	
H01L 23/44	(2006.01)	2013/0264721 A1*	10/2013	Landau	H01L 24/29 324/252
H01L 23/473	(2006.01)	2013/0307156 A1	11/2013	Bayerer	
H01L 23/50	(2006.01)	2014/0320124 A1	10/2014	David et al.	
H01L 25/00	(2006.01)	2014/0327436 A1*	11/2014	Castro Serrato	G01R 33/07 324/252
H01L 25/07	(2006.01)	2016/0014916 A1	1/2016	Ausserlechner et al.	
H01L 25/16	(2023.01)	2016/0341571 A1*	11/2016	Sun	G01D 5/142
H10N 50/10	(2023.01)	2016/0377689 A1*	12/2016	Babulano	G01R 33/091 324/252
H10N 52/00	(2023.01)	2017/0314969 A1*	11/2017	Ausserlechner	G01D 5/147

(52) **U.S. Cl.**
 CPC **G01R 33/091** (2013.01); **H01L 21/4817**
 (2013.01); **H01L 21/4871** (2013.01); **H01L**
21/565 (2013.01); **H01L 22/34** (2013.01);
H01L 23/057 (2013.01); **H01L 23/3675**
 (2013.01); **H01L 23/3735** (2013.01); **H01L**
23/44 (2013.01); **H01L 23/473** (2013.01);
H01L 23/50 (2013.01); **H01L 25/072**
 (2013.01); **H01L 25/16** (2013.01); **H01L 25/50**
 (2013.01); **H10N 50/10** (2023.02); **H10N**
52/00 (2023.02); **G01R 33/0005** (2013.01);
G01R 33/0017 (2013.01); **H01L 23/051**
 (2013.01)

FOREIGN PATENT DOCUMENTS

CN	103134974 A	6/2013
CN	103855102 A	6/2014
DE	102007044485 A1	4/2009
DE	102013103351 A1	10/2013
DE	102014106133 A1	11/2014
DE	102015009603 A1	1/2017
JP	2006038640 A	2/2006

OTHER PUBLICATIONS

“Current Sensing Using Linear Hall Sensors”, Application Note,
 Rev. 1.1, Infineon Technologies AG, Feb. 3, 2009.

“Dynamic Differential Hall Effect Sensor IC (TLE 4923)”, Data
 Sheet, Infineon Technologies AG, Jul. 1, 2000.

Schrieber-Prillwitz, Wolfgang, et al., “Architecture of an Integrated
 AMR Current Sensor (IACS) System for a Wide Range of Auto-
 motive Applications”, Sensor+Test Conferences 2011, Sensor Pro-
 ceedings, pp. 774-779.

(58) **Field of Classification Search**
 CPC H01L 25/072; H01L 21/565; H01L 23/50;
 H01L 23/057; H01L 23/3735; H01L
 25/50; H01L 22/34; H01L 23/44; H01L
 23/473; H01L 23/051; H10N 52/00;
 H10N 50/10; G01R 33/072; G01R
 15/207; G01R 33/091; G01R 33/0017;
 G01R 33/0005
 See application file for complete search history.

(56) **References Cited**
 U.S. PATENT DOCUMENTS
 6,819,095 B1 11/2004 Dubhashi et al.
 7,199,435 B2 4/2007 Elbanhawy

* cited by examiner

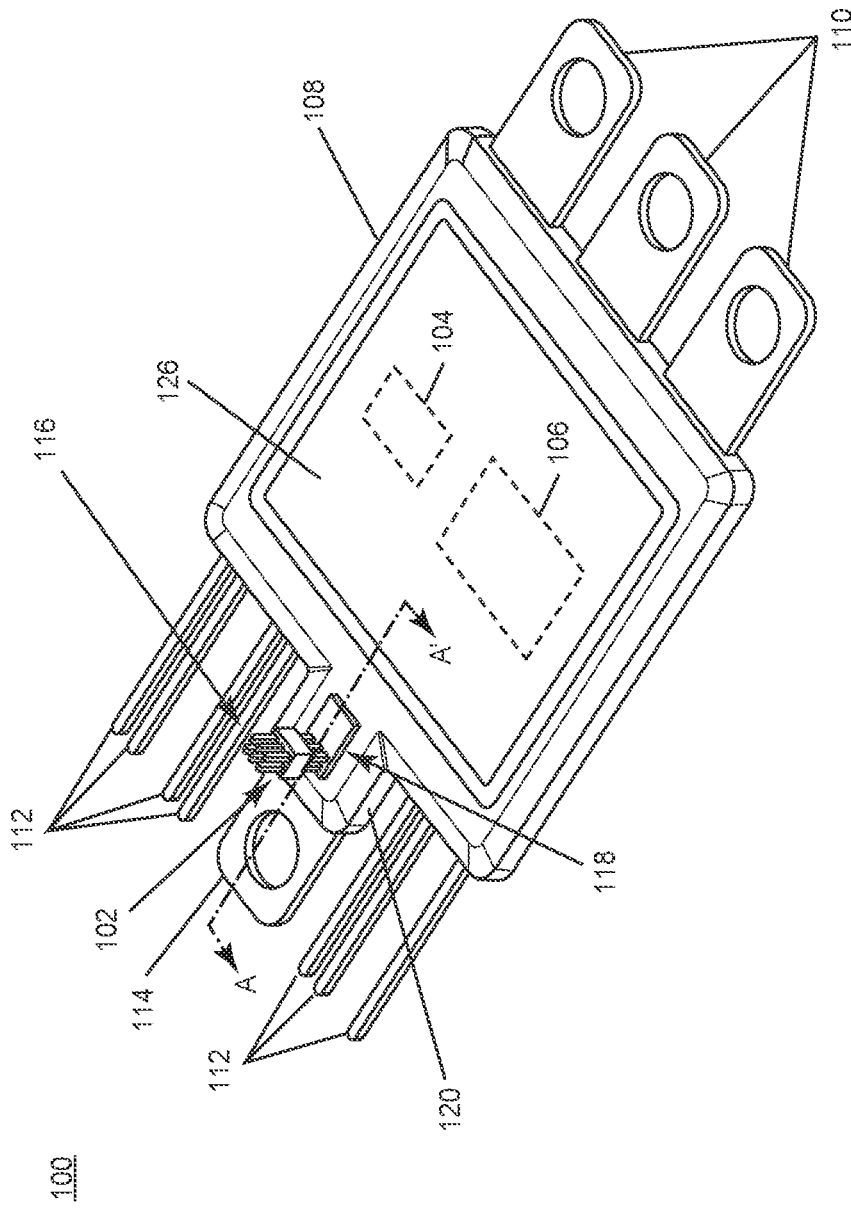

Figure 1

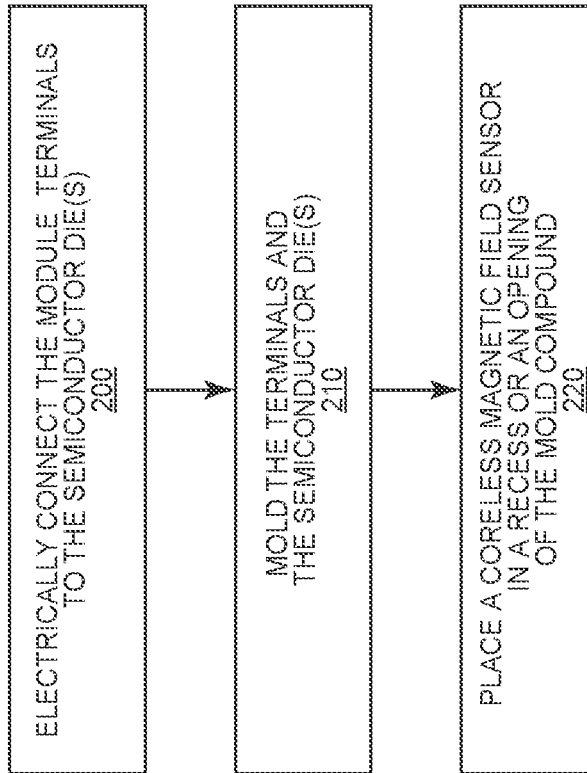

Figure 2

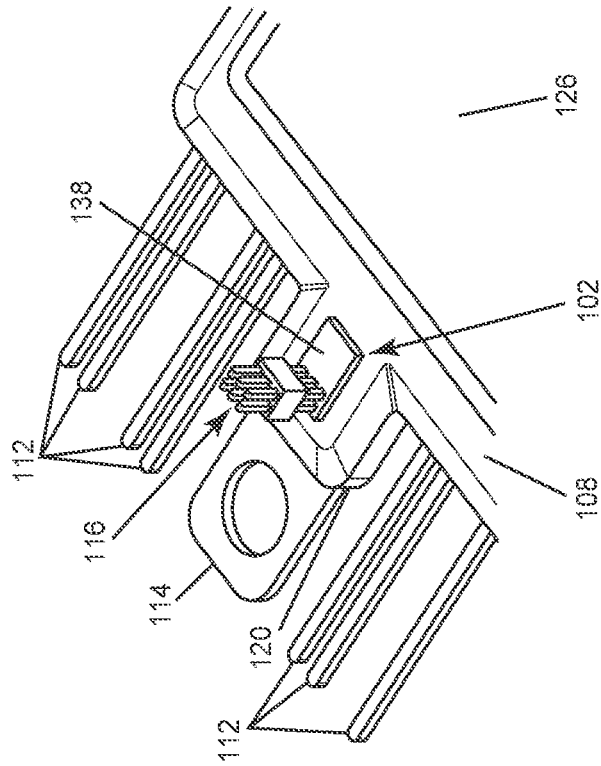

Figure 3B

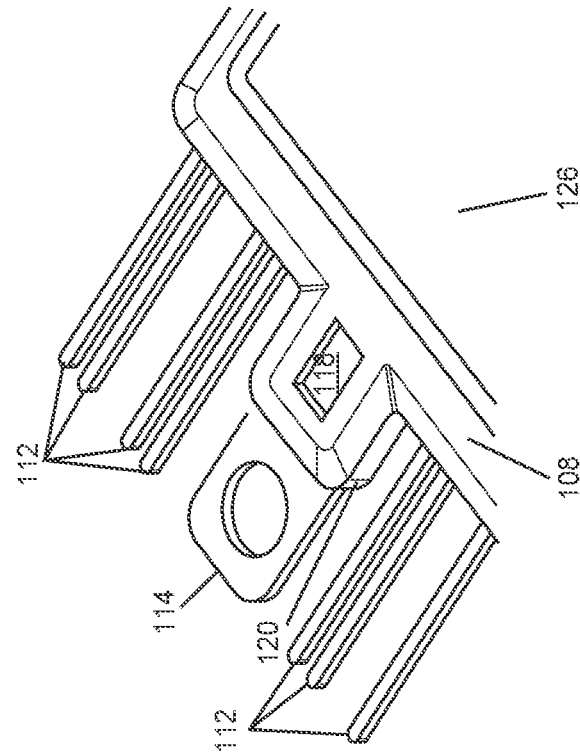

Figure 3A

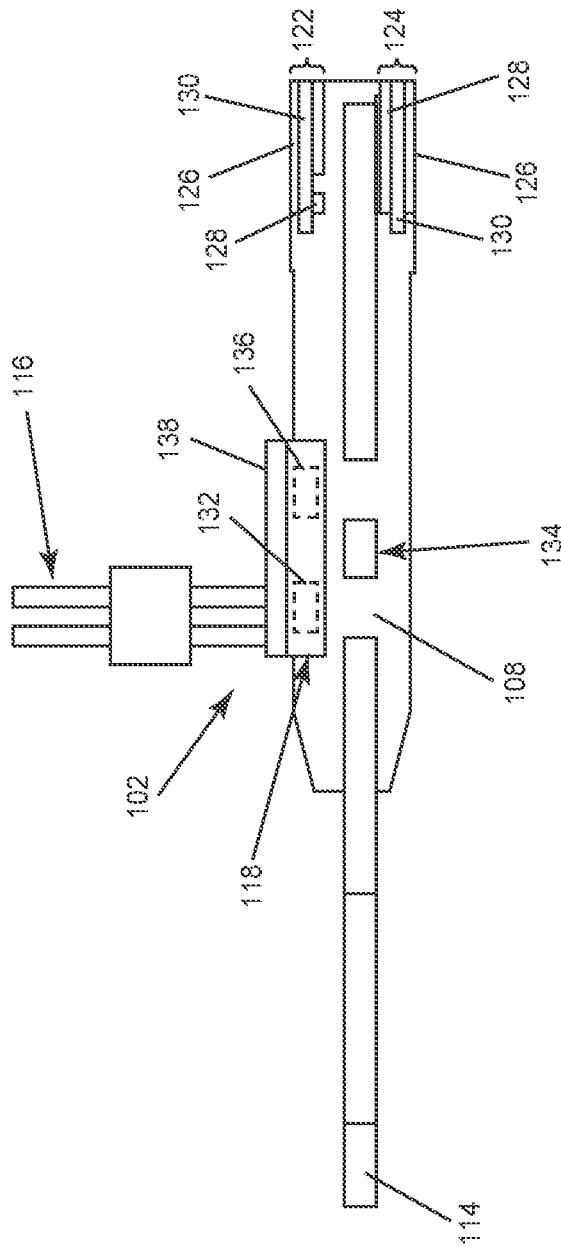

Figure 3C

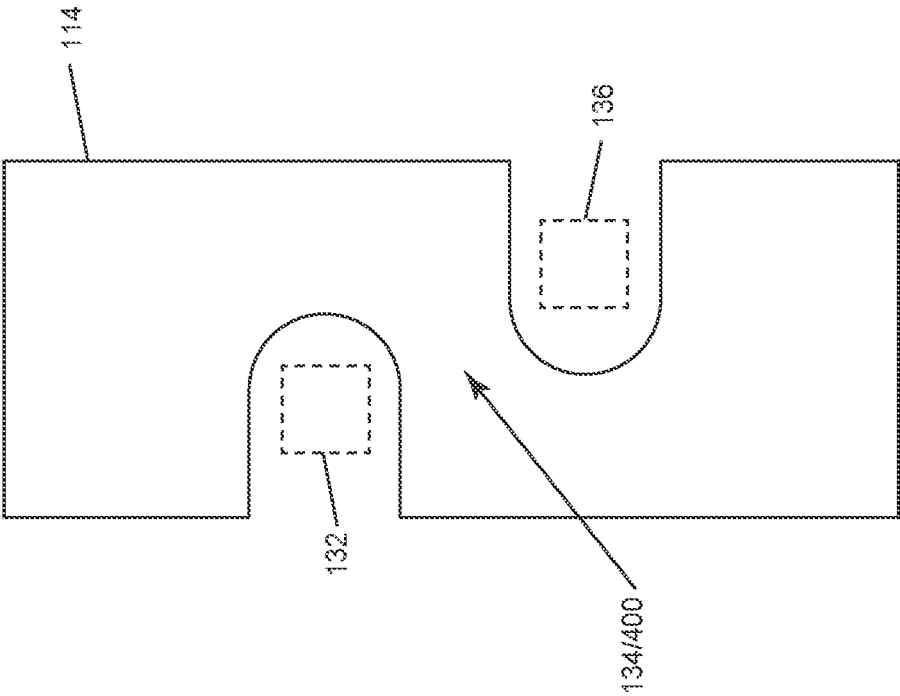

Figure 5

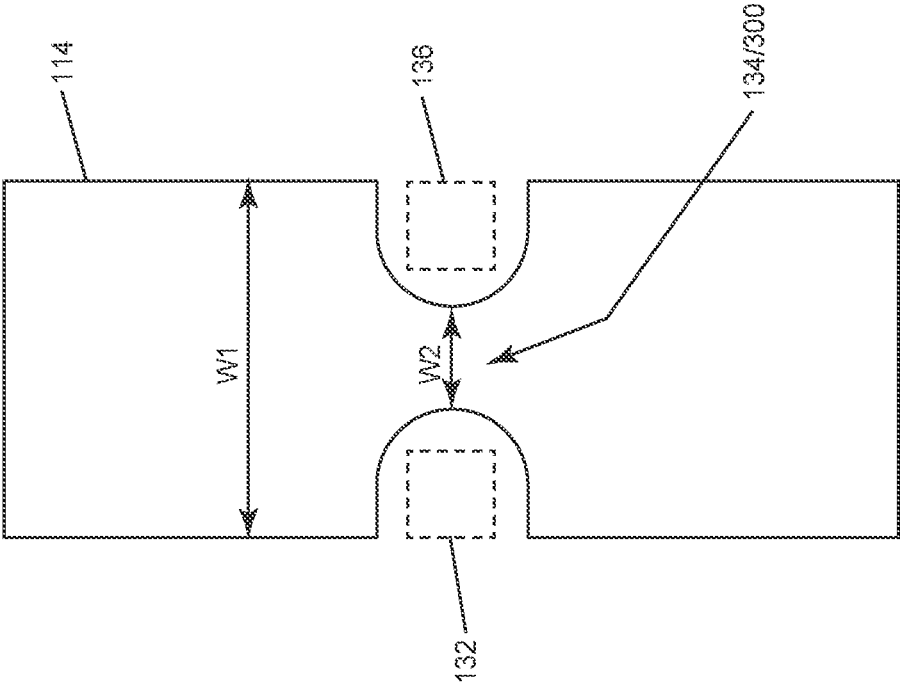

Figure 4

500

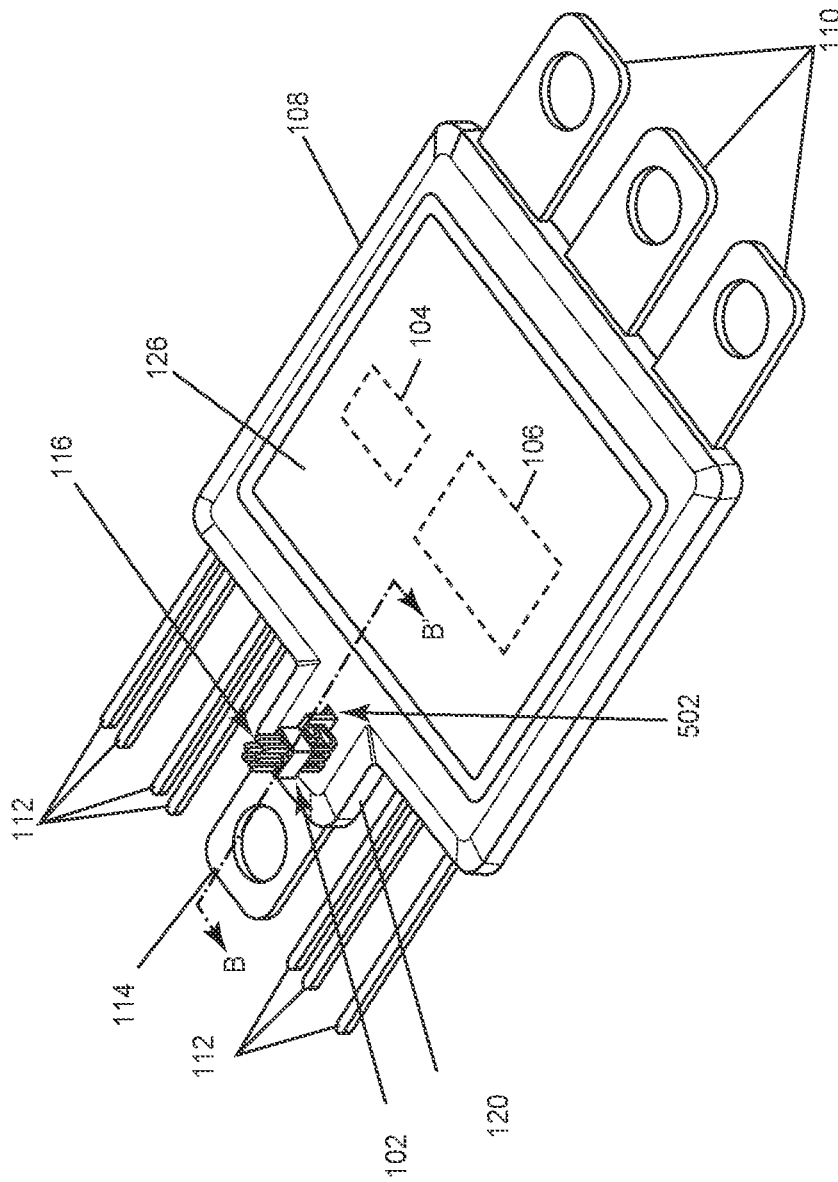

Figure 6

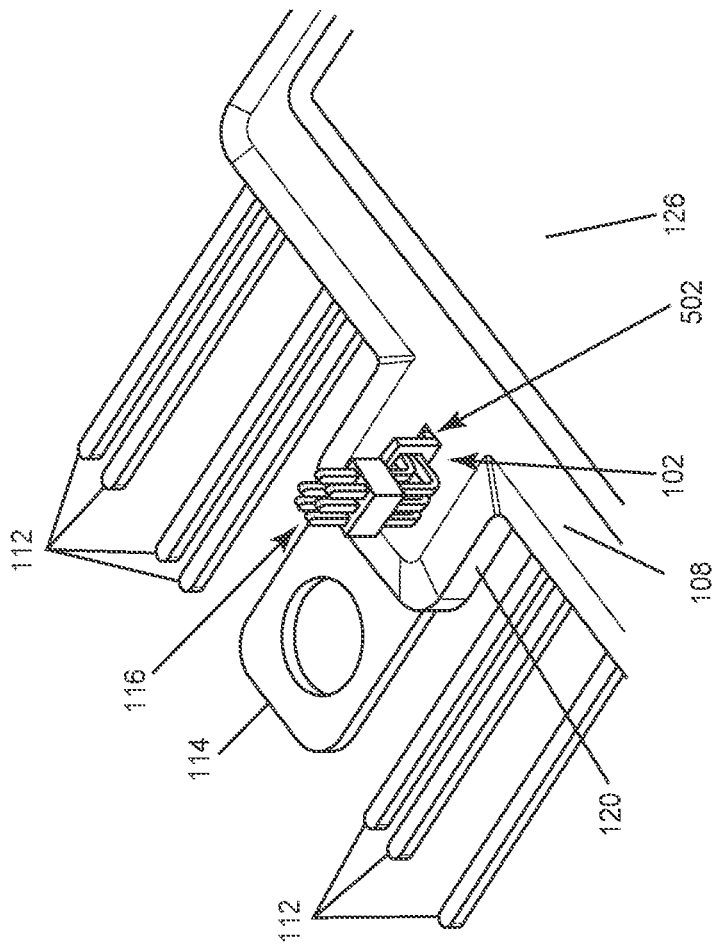

Figure 7B

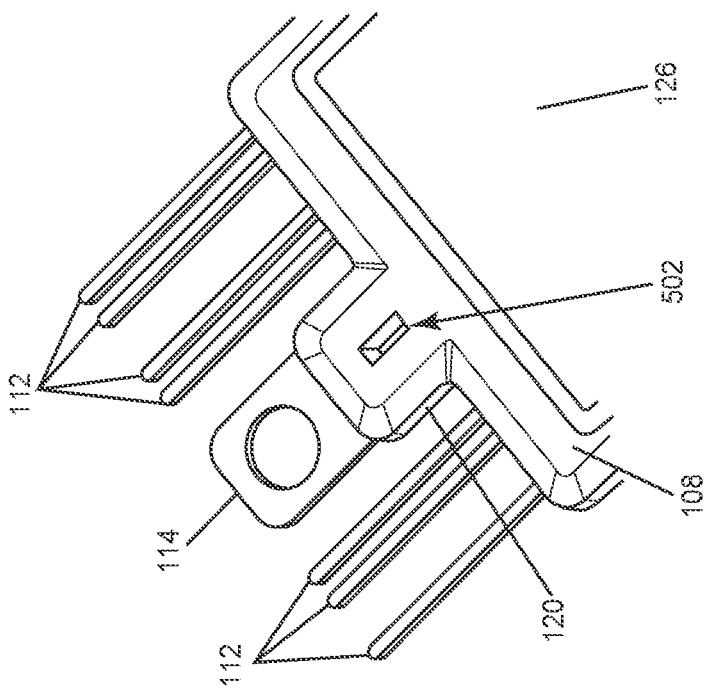

Figure 7A

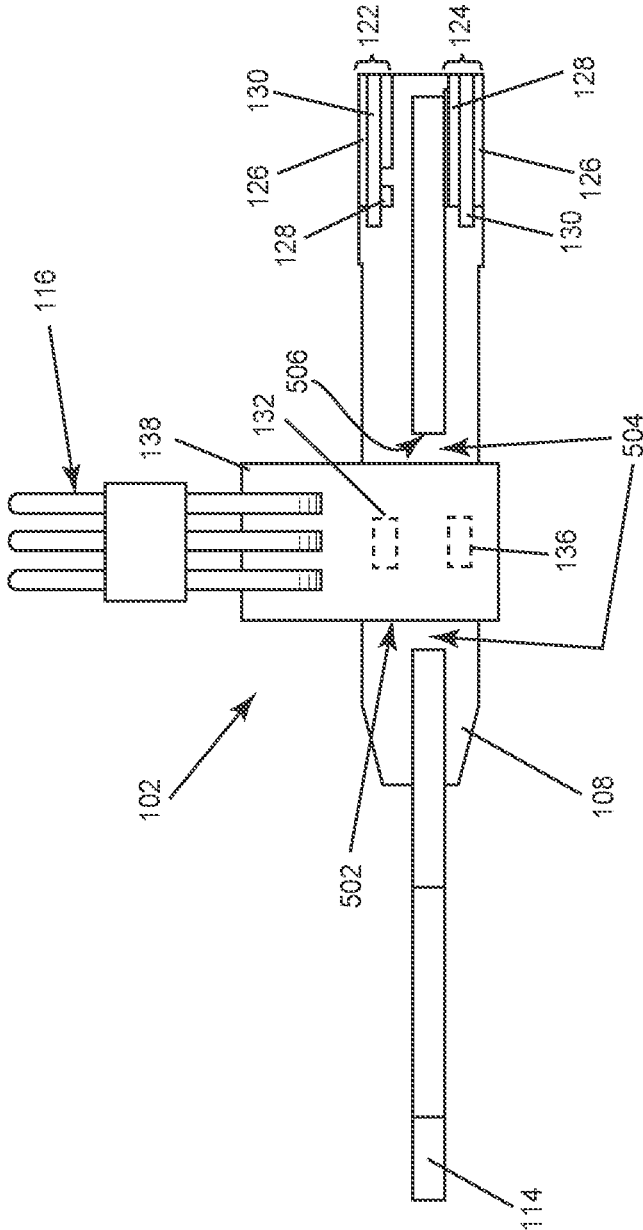

Figure 7C

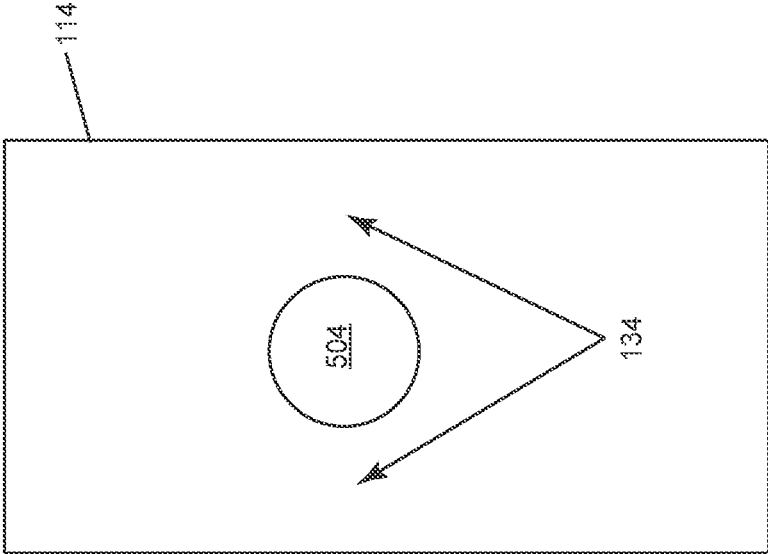

Figure 7D

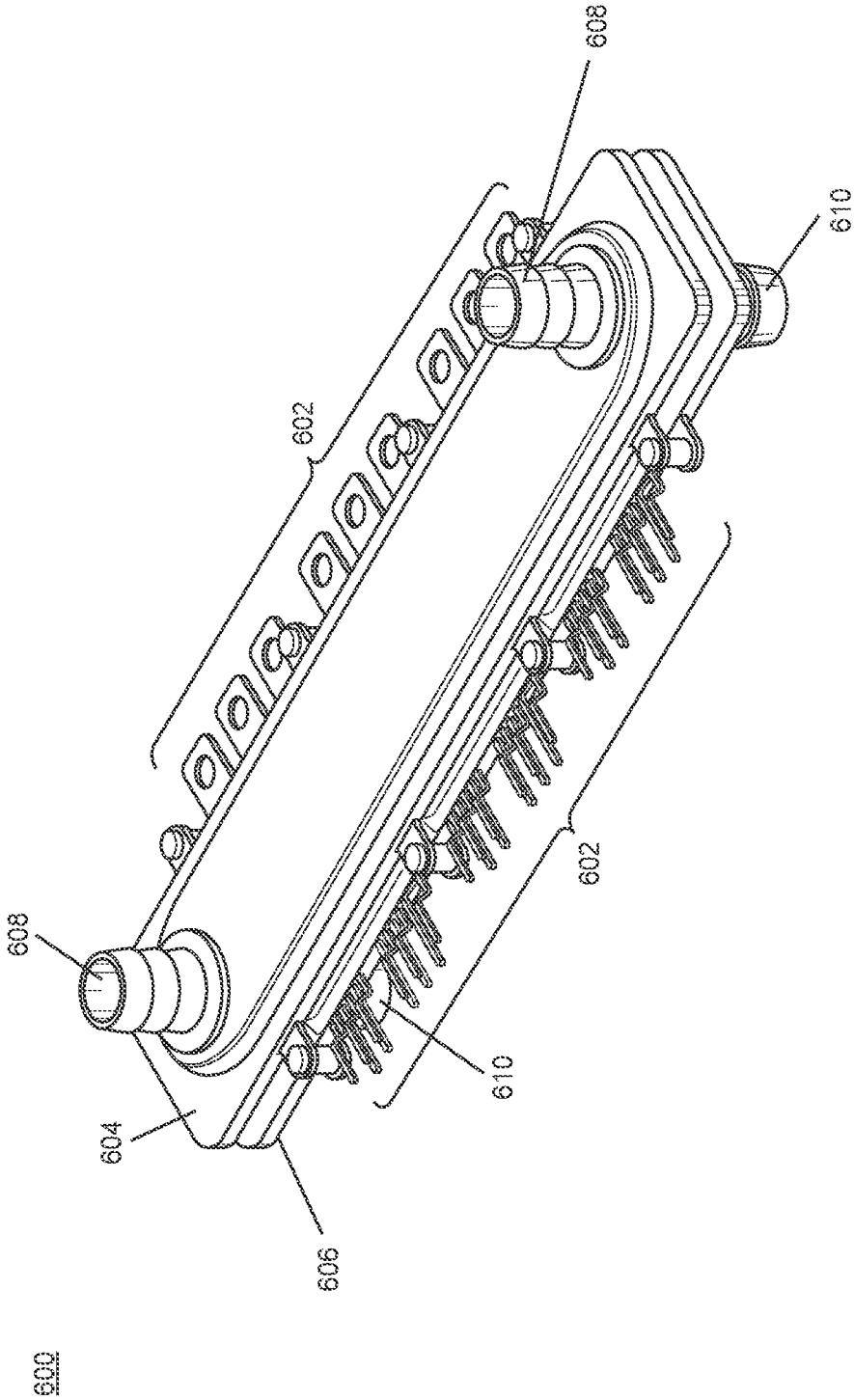

Figure 8

SEMICONDUCTOR MODULE WITH EXTERNAL POWER SENSOR

Matter enclosed in heavy brackets [] appears in the original patent but forms no part of this reissue specification; matter printed in italics indicates the additions made by reissue; a claim printed with strikethrough indicates that the claim was canceled, disclaimed, or held invalid by a prior post-patent action or proceeding.

BACKGROUND

Accurate operation of inverter packages or modules requires current sensing of the AC current to ensure effective system performance. AC current sensing is typically implemented using core-based magnetic sensors. Open-loop, core-based current sensors are limited in performance especially due to negative effects of the iron core. For example, open-loop, core-based current sensors suffer from hysteresis, saturation, non-linearity, temperature-dependent permeability, eddy current effects, etc. Some of the issues can be addressed using an external circuit for compensating the magnetic flux generated by the test current, and a probe for determining the zero-flux condition in the airgap. However, the additional circuitry, compensation winding and additional power dissipation in the compensation winding add significant cost to the overall sensing implementation.

In most cases, the intrinsic accuracy of core-based sensors is insufficient to meet end-customer requirements, e.g. for automotive traction inverters. Therefore, an end-of-line calibration may be required to compensate for gain and offset errors of the sensor. This calibration step is expensive since it requires to force high currents at high accuracy after the assembly of the inverter module and the current sensor. Since the calibration step is usually only performed at room temperature, the residual error due to lifetime drift and temperature dependency remains significant and impacts the overall system performance.

Thus, there is a need for an improved external power sensor for semiconductor modules.

SUMMARY

According to an embodiment of a semiconductor module, the semiconductor module comprises: a semiconductor die; a mold compound encasing the semiconductor die; a plurality of terminals electrically connected to the semiconductor die and protruding out of the mold compound, wherein a first one of the terminals has a constricted region covered by the mold compound, wherein the mold compound has a recess or an opening near the constricted region of the first terminal; and a coreless magnetic field sensor disposed in the recess or the opening of the mold compound and isolated from the first terminal by the mold compound, the coreless magnetic sensor configured to generate a signal in response to a magnetic field produced by current flowing in the constricted region of the first terminal, the magnitude of the signal being proportional to the amount of current flowing in the constricted region of the first terminal.

The coreless magnetic field sensor may be a magnetoresistive sensor or a Hall sensor.

Separately or in combination, the constricted region of the first terminal may comprise a tapered region over which the width of the first terminal narrows, the recess of the mold compound may be near the tapered region of the first terminal, the coreless magnetic field sensor may be a single-

ended sensor disposed in the recess of the mold compound and comprise a single sensing element positioned adjacent one side of the tapered region, and the single sensing element maybe isolated from the tapered region by the mold compound.

Separately or in combination, the constricted region of the first terminal may comprise a tapered region over which the width of the first terminal narrows, the recess of the mold compound may be near the tapered region of the first terminal, the coreless magnetic field sensor may be a differential sensor disposed in the recess of the mold compound and comprise a first sensing element positioned adjacent a first side of the tapered region and a second sensing element positioned adjacent a second side of the tapered region opposite the first side, and the first and second sensing elements may be isolated from the tapered region by the mold compound.

Separately or in combination, the constricted region of the first terminal may comprise a serpentine region, the recess of the mold compound may be near the serpentine region of the first terminal, wherein the coreless magnetic field sensor is a single-ended sensor disposed in the recess of the mold compound and comprises a single sensing element positioned adjacent one side of the serpentine region, and wherein the single sensing element is isolated from the serpentine region by the mold compound.

Separately or in combination, the constricted region of the first terminal may comprise a serpentine region, the recess of the mold compound may be near the serpentine region of the first terminal, the coreless magnetic field sensor may be a differential sensor disposed in the recess of the mold compound and comprise a first sensing element positioned adjacent a first side of the serpentine region and a second sensing element positioned adjacent a second side of the serpentine region opposite the first side, and the first and second sensing elements may be isolated from the serpentine region by the mold compound.

Separately or in combination, the constricted region of the first terminal may comprise a region of the first terminal having an opening, the opening of the mold compound may be aligned with the opening in the first terminal, the coreless magnetic field sensor may be a single-ended sensor disposed in the opening of the mold compound and comprise a single sensing element positioned above or below the opening in the first terminal, and the single sensing element may be isolated from a sidewall of the opening in the first terminal by the mold compound.

Separately or in combination, the constricted region of the first terminal may comprise a region of the first terminal having an opening, the opening of the mold compound may be aligned with the opening in the first terminal, the coreless magnetic field sensor may be a differential sensor disposed in the opening of the mold compound and comprise a first sensing element positioned above the opening in the first terminal and a second sensing element positioned below the opening in the first terminal, and the first and second sensing elements may be isolated from a sidewall of the opening in the first terminal by the mold compound.

Separately or in combination, the mold compound may have a protrusion which covers more of the first terminal than other ones of the terminals protruding from a same side of the mold compound as the first terminal, and the recess or the opening of the mold compound may be formed in the protrusion.

Separately or in combination, the semiconductor die may be a power semiconductor die, the semiconductor module

3

may have double-sided cooling, and the first terminal may be an AC output terminal of the power semiconductor die.

According to an embodiment of a cooling system, the cooling system comprises: a plurality of individual semiconductor modules each comprising: a semiconductor die; a mold compound encasing the semiconductor die; a plurality of terminals electrically connected to the semiconductor die and protruding out of the mold compound, wherein a first one of the terminals has a constricted region covered by the mold compound, wherein the mold compound has a recess or an opening near the constricted region of the first terminal; and a coreless magnetic field sensor disposed in the recess or the opening of the mold compound and isolated from the first terminal by the mold compound, the coreless magnetic sensor configured to generate a signal in response to a magnetic field produced by current flowing in the constricted region of the first terminal, the magnitude of the signal being proportional to the amount of current flowing in the constricted region of the first terminal; and a first lid joined to a second lid to form a sealed housing which includes the plurality of individual semiconductor modules and a cavity between the lids and the individual semiconductor modules for fluid flow via a plurality of ports formed in the first and/or second lid.

Each coreless magnetic field sensor of the cooling system may be a magnetoresistive sensor or a Hall sensor.

Separately or in combination, the constricted region of each first terminal may comprise a tapered region over which the width of the first terminal narrows, the recess of the mold compound may be near the tapered region of the first terminal, the coreless magnetic field sensor may be a single-ended sensor disposed in the recess of the mold compound and comprise a single sensing element positioned adjacent one side of the tapered region, and the single sensing element may be isolated from the tapered region by the mold compound.

Separately or in combination, the constricted region of each first terminal may comprise a tapered region over which the width of the first terminal narrows, the recess of the mold compound may be near the tapered region of the first terminal, the coreless magnetic field sensor may be a differential sensor disposed in the recess of the mold compound and comprise a first sensing element positioned adjacent a first side of the tapered region and a second sensing element positioned adjacent a second side of the tapered region opposite the first side, and the first and second sensing elements may be isolated from the tapered region by the mold compound.

Separately or in combination, the constricted region of each first terminal may comprise a serpentine region, the recess of the mold compound may be near the serpentine region of the first terminal, the coreless magnetic field sensor may be a single-ended sensor disposed in the recess of the mold compound and comprise a single sensing element positioned adjacent one side of the serpentine region, and the single sensing element may be isolated from the serpentine region by the mold compound.

Separately or in combination, the constricted region of each first terminal may comprise a serpentine region, the recess of the mold compound may be near the serpentine region of the first terminal, the coreless magnetic field sensor may be a differential sensor disposed in the recess of the mold compound and comprise a first sensing element positioned adjacent a first side of the serpentine region and a second sensing element positioned adjacent a second side of the serpentine region opposite the first side, and the first and

4

second sensing elements may be isolated from the serpentine region by the mold compound.

Separately or in combination, the constricted region of each first terminal may comprise a region of the first terminal having an opening, the opening of the mold compound may be aligned with the opening in the first terminal, the coreless magnetic field sensor may be a single-ended sensor disposed in the opening of the mold compound and comprise a single sensing element positioned above or below the opening in the first terminal, and the single sensing element may be isolated from a sidewall of the opening in the first terminal by the mold compound.

Separately or in combination, the constricted region of each first terminal may comprise a region of the first terminal having an opening, the opening of the mold compound may be aligned with the opening in the first terminal, the coreless magnetic field sensor may be a differential sensor disposed in the opening of the mold compound and comprise a first sensing element positioned above the opening in the first terminal and a second sensing element positioned below the opening in the first terminal, and the first and second sensing elements may be isolated from a sidewall of the opening in the first terminal by the mold compound.

Separately or in combination, the mold compound of each individual semiconductor module may have a protrusion which covers more of the first terminal than other ones of the terminals protruding from a same side of the mold compound as the first terminal, and the recess or the opening of the mold compound may be formed in the protrusion.

Separately or in combination, each semiconductor die may be a power semiconductor die, wherein each individual semiconductor module has double-sided cooling, and each first terminal may be an AC output terminal of the power semiconductor die.

According to an embodiment of a method of manufacturing a semiconductor module, the method comprises: electrically connecting a plurality of terminals to a semiconductor die; molding the plurality of terminals and the semiconductor die so that the semiconductor die is encased in a mold compound and the plurality of terminals protrude out of the mold compound, wherein a first one of the terminals has a constricted region covered by the mold compound, wherein the mold compound has a recess or an opening near the constricted region of the first terminal; and placing a coreless magnetic field sensor in the recess or the opening of the mold compound, the coreless magnetic field sensor being isolated from the first terminal by the mold compound and configured to generate a signal in response to a magnetic field produced by current flowing in the constricted region of the first terminal, the magnitude of the signal being proportional to the amount of current flowing in the constricted region of the first terminal.

Those skilled in the art will recognize additional features and advantages upon reading the following detailed description, and upon viewing the accompanying drawings.

BRIEF DESCRIPTION OF THE FIGURES

The elements of the drawings are not necessarily to scale relative to each other. Like reference numerals designate corresponding similar parts. The features of the various illustrated embodiments can be combined unless they exclude each other. Embodiments are depicted in the drawings and are detailed in the description which follows.

5

FIG. 1 illustrates perspective view of an embodiment of a semiconductor module having a coreless magnetic field sensor.

FIG. 2 illustrates a flow diagram of an embodiment of a method of manufacturing the semiconductor module shown in FIG. 1.

FIG. 3A illustrates an enlarged view of a section of the semiconductor module of FIG. 1 before the coreless magnetic field sensor is disposed in a recess of the mold compound.

FIG. 3B shows the same view of the semiconductor module as in FIG. 3A, but after the coreless magnetic field sensor is disposed in the recess.

FIG. 3C illustrates a partial cross-sectional view of the semiconductor module along the line labelled A-A' in FIG. 1.

FIG. 4 illustrates a top plan view of an embodiment of a terminal of the semiconductor module of FIG. 1 having a constricted region in close proximity to the coreless magnetic field sensor.

FIG. 5 illustrates a top plan view of another embodiment of a terminal of the semiconductor module of FIG. 1 having a constricted region in close proximity to the coreless magnetic field sensor.

FIG. 6 illustrates perspective view of another embodiment of a semiconductor module having a coreless magnetic field sensor.

FIG. 7A illustrates an enlarged view of a section of the semiconductor module of FIG. 6 before the coreless magnetic field sensor is disposed in an opening of the mold compound.

FIG. 7B shows the same view of the semiconductor module as in FIG. 7A, but after the coreless magnetic field sensor is disposed in the recess.

FIG. 7C illustrates a partial cross-sectional view of the semiconductor module along the line labelled B-B' in FIG. 6.

FIG. 7D illustrates a top plan view of an embodiment of a terminal of the semiconductor module of FIG. 6 having an opening for receiving the coreless magnetic field sensor.

FIG. 8 illustrates perspective view of an embodiment of a cooling system having a plurality of individual semiconductor modules each with an integrated, coreless magnetic field sensor.

DETAILED DESCRIPTION

The embodiments described herein integrate a coreless, open-loop current sensor into the package of a power module. A terminal of the power module has a sensing structure that generates a magnetic field used for current sensing, and the molded body of the package is designed such that the coreless current sensor can be mounted and aligned towards the sensing structure. Since the coreless sensor does not have an iron core, the corresponding negative effects (e.g. temperature dependency, hysteresis, etc.) are not present. To suppress external stray fields, the design may be implemented as a differential sensing concept. To implement a differential design, the coreless current sensor may be aligned in multiple ways relative to the current rail. Both lateral and vertical integration of the sensor are described herein. The sensor implementation may instead be single-ended, e.g., in the case of low-noise applications. The molded body of the module is configured to receive the coreless magnetic field sensor such that the current sensor is positioned either above or below the terminal or in the

6

terminal. The molded module body may be configured to isolate the current sensor from the terminal being sensed.

FIG. 1 illustrates an embodiment of a semiconductor module 100 with an integrated, coreless, open-loop current sensor 102. The semiconductor module 100 includes one or more semiconductor dies 104, 106 such as a power MOSFET (metal-oxide-semiconductor field-effect transistor), HEMT (high-electron mobility transistor), IGBT (insulated gate bipolar transistor), JFET (junction FET) or similar device. In one embodiment, the one or more semiconductor dies 104, 106 are SiC dies which do not have internal current sense capability. The one or more semiconductor dies 104, 106 are encased by a mold compound 108 and therefore out of view in FIG. 1 and illustrated by respective dashed boxes.

The semiconductor module 100 also includes a plurality of terminals 110, 112, 114 electrically connected to the one or more semiconductor dies 104, 106 and protruding out of the mold compound 108. For example, the terminals 110, 112, 114 may be electrically connected to the one or more semiconductor dies 104, 106 by wire bonds, metal ribbons, metal clips, etc. In one embodiment, the terminals 110, 112, 114 are leads of a lead frame. In another embodiment, at least the power terminals 110, 114 are busbars or tabs. Still other types of terminals may be used. Different types of terminals may be used in the same module. For example, leadframe-type terminals may be used for the control and/or sensing connections and busbar or tab type terminals may be used for power connections. The number and type of terminals 110, 112, 114 provided depends on the type of semiconductor module.

For example, in the case of a half-bridge power semiconductor module, a high-side semiconductor die 104 and a low-side semiconductor die 106 are encased by the mold compound 108. A first group of terminals 112 of the semiconductor module 100 may be control and sense terminals, for providing control signals to the high-side and low-side semiconductor dies 104, 106 and for receiving telemetry data from the module 100 such as current sense information, temperature sense information, etc. The high-side and low-side semiconductor dies 104, 106 may be SiC dies which do not have internal current sense capability. A second group of terminals 110 are DC supply terminals, for providing positive and negative (or ground) potentials to the high-side and low-side semiconductor dies 104, 106. The high-side and low-side semiconductor dies 104, 106 are electrically coupled in series at a common output node. Another terminal 114 is an AC output terminal electrically connected to the common output node of the dies 104, 106.

The AC output terminal 114 has a constricted region covered by the mold compound 108. The constricted region is out of view in FIG. 1.

The coreless magnetic field sensor 102 integrated in the semiconductor module 100 is configured to generate a signal in response to a magnetic field produced by current flowing in the constricted region of the AC output terminal 114 of the module 100. The coreless magnetic field sensor 102 has one or more terminals 116 such as pins, leads, etc. for accessing the signal generated by the sensor 102. The coreless magnetic field sensor 102 may be calibrated during an end-of-line test procedure performed on the semiconductor module 100 prior to shipment. Doing so yield improved accuracy compared to a customer calibration process, since the end-of-line test procedure is performed in a controlled environment with multi-temperature calibration capability and may omit high current calibration steps which are typically performed in the field.

The magnitude of the signal generated by the coreless magnetic field sensor **102** is proportional to the amount of current flowing in the constricted region of the AC output terminal **114**. Any type of coreless magnetic field sensor may be used. In one embodiment, the coreless magnetic field sensor **102** is a magnetoresistive (XMR) sensor such as an anisotropic magnetoresistive (AMR) sensor, giant magnetoresistive (GMR) sensor or tunnel magnetoresistive (TMR) sensor. In the case of an XMR sensor, the electric resistivity of a metal, semi-metal or semiconductor included in the sensor **102** changes under the influence of a magnetic field and in proportion to the amount of current flowing in the constricted region of the AC output terminal **114**. In another embodiment, the coreless magnetic field sensor **102** is a Hall sensor. In the case of a Hall sensor, a transducer included in the sensor **102** has an output voltage which varies in response to the magnetic field and in proportion to the amount of current flowing in the constricted region of the AC output terminal **114**.

According to the embodiment illustrated in FIG. 1, the mold compound **108** has a recess **118** near the constricted region of the AC output terminal **114**. The coreless magnetic field sensor **102** is disposed in the recess **118** of the mold compound **108**. In one embodiment, the mold compound **108** has a protrusion **120** which covers more of the AC output terminal **114** than other ones of the terminals **112** protruding from the same side of the mold compound **108** as the AC output terminal **114**. The recess **118** of the mold compound **108** is formed in the protrusion **120**.

FIG. 2 illustrates an embodiment of a method of manufacturing the semiconductor module **100** shown in FIG. 1. The method includes electrically connecting the terminals **110**, **112**, **114** to the one or more semiconductor dies **104**, **106** (Block **200**). For example, the terminals **110**, **112**, **114** may be electrically connected to the one or more semiconductor dies **104**, **106** by wire bonding, metal ribbons, metal clips, etc. The method further includes molding the terminals **110**, **112**, **114** and the one or more semiconductor dies **104**, **106** so that the one or more semiconductor dies **104**, **106** are encased in the mold compound **108** and the terminals **110**, **112**, **114** protrude out of the mold compound **108**, the AC output terminal **114** has a constricted region covered by the mold compound **108**, and the mold compound **108** has a recess **118** near the constricted region of the AC output terminal **114** (Block **210**). Any typical molding process may be used such as injection molding, film-assisted molding, transfer molding, etc. A pin in a mold tool may be used to form the protrusion **120** of the mold compound **108**. The method also includes placing the coreless magnetic field sensor **102** in the recess **118** of the mold compound **108** (Block **220**). The coreless magnetic field sensor **102** may be secured in the recess by glue, adhesive tape, etc., or clipped in place by the shape and features of the recess **118**.

FIG. 3A illustrates an enlarged view of a section of the semiconductor module **100** before the coreless magnetic field sensor **102** is disposed in the recess **118** of the mold compound **108**. FIG. 3B shows the same view of the semiconductor module **100** as in FIG. 3A, but after the coreless magnetic field sensor **102** is disposed in the recess **118**. FIG. 3C illustrates a partial cross-sectional view of the semiconductor module **100** along the line labelled A-A' in FIG. 1. The semiconductor module **100** may include a first substrate **122** such as a PCB (printed circuit board) or DCB (direct copper bonded) substrate to which the high-side power semiconductor die **104** (out of view in FIG. 3C) is attached and a second substrate **124** such as a PCB or DCB substrate to which the low-side power semiconductor die

106 (also out of view in FIG. 3C). With this configuration, the semiconductor module **100** may have double-sided cooling.

For example, in the case of an arrangement of stacked DCB substrates **122**, **124**, each DCB substrate **122**, **124** has two metallized surfaces **126**, **128** separated by an insulative substrate **130** such as ceramic. The top-metallized side **126** of the upper DCB substrate **122** provides cooling at one side of the semiconductor module **100**, whereas the bottom-metallized side **126** of the lower DCB substrate **124** provides cooling at the opposite side of the module **100**. Double-sided cooling may also be realized by using PCB substrates **122**, **124**. Double-side cooling is advantageous for high power applications such as automotive power electronics. The one or more semiconductor dies **104**, **106** may be attached to the same substrate instead of separate substrates.

Further according to the embodiment shown in FIG. 3C, the coreless magnetic field sensor **102** may be a single-ended or differential sensor disposed in the recess **118** of the mold compound **108**. In the case of a differential sensor, the coreless magnetic field sensor **102** has a first sensing element **132** positioned adjacent a first side of the constricted region **134** of the AC output terminal **114** and a second sensing element **136** positioned adjacent a second side of the constricted region **134** opposite the first side. The differential coreless magnetic field sensor **102** generates a signal which is a linear function of the differential flux density of the magnetic field passing through the first and second sensing elements **132**, **136**. One of the sensing elements **132**, **136** may be omitted, for example in low-noise applications, to yield a single-ended coreless magnetic field sensor **102**. In this embodiment, a single sensing element **132** (or **136**) is positioned adjacent one side of the constricted region **134** of the AC output terminal **114** of the semiconductor module **100**. In either the differential or single-ended case, the sensing element(s) **132**, **136** of the coreless magnetic field sensor **102** may be attached to a substrate **138** such as a PCB to which the terminals **116** of the sensor **102** are also attached. In both cases, each sensing element **132**, **136** of the coreless magnetic field sensor **102** is isolated from the constricted region **134** of the AC output terminal **114** by the mold compound **108** to ensure proper electrical isolation and accurate sensing of the current flowing in the constricted region **134** of the terminal **114**.

FIG. 4 illustrates an embodiment of the part of the AC output terminal **114** covered by the mold compound **108** and having the constricted region **134**. The mold compound **108** is not shown in FIG. 4 to provide an unobstructed view of the constricted region **134**. According to this embodiment, the constricted region **134** of the AC output terminal **114** is a tapered region **300** over which the width of the terminal **114** narrows from a larger width **W1** to a smaller width **W2**. In the case of a differential coreless magnetic field sensor **102**, the sensor **102** has sensing elements **132**, **136** positioned adjacent opposite sides of the tapered region **300** of the AC output terminal **114**. In the case of a single-ended coreless magnetic field sensor **102**, one of the sensing elements **132** (or **136**) shown in FIG. 4 is omitted. In either case, the recess **118** of the mold compound **108** is near the tapered region **300** of the AC output terminal **114** and the (differential or single-ended) coreless magnetic field sensor **102** is disposed in the recess **118** of the mold compound **108**, e.g., as shown in FIG. 1 and FIGS. 3A-3C.

FIG. 5 illustrates another embodiment of the part of the AC output terminal **114** covered by the mold compound **108** and having the constricted region **134**. The mold compound **108** is not shown in FIG. 5 to provide an unobstructed view

of the constricted region **134**. According to this embodiment, the constricted region **134** of the AC output terminal **114** is a serpentine region **400** of the terminal **114** which winds or turns one way and then another. In the case of a differential coreless magnetic field sensor **102**, the sensor **102** has sensing elements **132**, **136** positioned adjacent opposite sides of the serpentine region **400** of the AC output terminal **114**. In the case of a single-ended coreless magnetic field sensor **102**, one of the sensing elements **132** (or **136**) shown in FIG. **5** is omitted. In either case, the recess **118** of the mold compound **108** is near the serpentine region **400** of the AC output terminal **114** and the (differential or single-ended) coreless magnetic field sensor **102** is disposed in the recess **118** of the mold compound **108**, e.g., as shown in FIG. **1** and FIGS. **3A-3C**.

The embodiments described above provide a lateral-type integration of a coreless magnetic field sensor which provides a minimum solution height and maximum field sensing. However, the lateral-type integrated sensing structure may create a significant bottleneck for the current in the AC output terminal of the semiconductor module. The resulting higher power dissipation may limit the maximum output current capability of the semiconductor module. Describe next is an embodiment of a semiconductor module having a vertical-type integration of a coreless magnetic field sensor. The vertical-type inserted sensing structure offers lower insertion resistance at the expense of reduced sensing field strength.

FIG. **6** illustrates another embodiment of a semiconductor module **500** with an integrated, coreless, open-loop current sensor **102**. The embodiment illustrated in FIG. **6** is similar to the embodiment illustrated in FIG. **1**. Different, however, the constricted region **134** of the AC output terminal **114** is a region of the terminal having an opening which is out of view in FIG. **6**. According to this embodiment, the mold compound **108** has an opening **502** aligned with the opening in the AC output terminal **114**. The coreless magnetic field sensor **102** is disposed in the opening **502** of the mold compound **108**. The mold compound **108** covers the sidewall of the opening in the AC output terminal **114**, thereby isolating the coreless magnetic field sensor **102** from the sidewall of the opening in the AC output terminal **114**. In one embodiment, the mold compound **108** has a protrusion **120** which covers more of the AC output terminal **114** than other ones of the terminals **112** protruding from the same side of the mold compound **108** as the AC output terminal **114**. The opening **502** of the mold compound **108** is formed in the protrusion **120**.

The method illustrated in FIG. **2** may be used to manufacture the semiconductor module **500** shown in FIG. **6**. Different, however, the coreless magnetic field sensor **102** is placed in the opening **502** of the mold compound **108** instead of a recess. The coreless magnetic field sensor **102** may be secured by in the opening **502** of the mold compound **108** by glue, adhesive tape, etc., or clipped in place by the opening **502**.

FIG. **7A** illustrates an enlarged view of a section of the semiconductor module **500** shown in FIG. **6** before the coreless magnetic field sensor **102** is disposed in the opening **502** of the mold compound **108**. FIG. **7B** shows the same view of the semiconductor module **500** as in FIG. **3A**, but after the coreless magnetic field sensor **102** is disposed in the opening **502** of the mold compound **108**. FIG. **7C** shows a partial cross-sectional view of the semiconductor module **500** along the line labelled B-B' in FIG. **6**.

In one embodiment, the coreless magnetic field sensor **102** is a differential sensor disposed in the opening **502** of

the mold compound **108** and having a first sensing element **132** positioned above the opening **504** in the AC output terminal **114** of the semiconductor module **500** and a second sensing element **136** positioned below the opening **504** in the AC output terminal **114**. In another embodiment, the coreless magnetic field sensor **102** is a single-ended sensor. According to this embodiment, one of the sensing elements **132** (or **136**) shown in FIG. **7C** is omitted. In either the differential or single-ended case, each sensing element **132**, **136** of the coreless magnetic field sensor **102** is isolated from the sidewall **506** of the opening **504** in the AC output terminal **114** by the mold compound **108** to ensure proper electrical isolation and accurate sensing of the current flowing in the constricted region **134** of the AC output terminal. FIG. **7D** shows the part of the AC output terminal **114** covered by the mold compound **108** and having the opening **504** in which the coreless magnetic field sensor **102** is inserted. The mold compound **108** is not shown in FIG. **7D** to provide an unobstructed view of the opening **504** and corresponding constricted region **134**.

FIG. **8** illustrates an embodiment of a cooling system **600** that includes a plurality of individual semiconductor modules of the kind previously described herein. The individual semiconductor modules are out of view in FIG. **8**, and may have the lateral-type integrated sensing structure as shown in FIGS. **1** and **3A-3C** or the vertical-type integrated sensing structure as shown in FIGS. **6** and **7A-7C**. That is, each individual semiconductor module may include one or more semiconductor dies, a mold compound encasing each semiconductor die, a plurality of terminals **602** electrically connected to the semiconductor die(s) and protruding out of the mold compound, wherein a first one of the terminals has a constricted region covered by the mold compound, wherein the mold compound has a recess or an opening near the constricted region of the first terminal, and a coreless magnetic field sensor disposed in the recess or the opening of the mold compound and isolated from the first terminal by the mold compound. The coreless magnetic sensor is configured to generate a signal in response to a magnetic field produced by current flowing in the constricted region of the first terminal, the magnitude of the signal being proportional to the amount of current flowing in the constricted region of the first terminal, as previously explained herein.

The cooling system **600** further includes a first lid **604** joined to a second lid **606** to form a sealed housing. The sealed housing includes the individual semiconductor modules and a cavity between the lids and the individual semiconductor modules. The cavity is out of view in FIG. **8**. The first lid **604** has one or more ports **608** and the second lid **606** has one or more ports **610**, so that fluid such as water, a coolant, etc. can flow in the cavity between the lids **604**, **606** and the individual semiconductor modules. In the case of double-sided cooling, the fluid may flow along both main sides of the individual semiconductor modules. In the case of single-sided cooling, the fluid may flow along only the main side of the individual semiconductor modules with the cooling structure. The lid **604**, **606** adjacent the side of the individual semiconductor modules without a cooling structure may not have any ports. The lids **604**, **606** may be made of metal or plastic, or a combination of metal and plastic.

Terms such as "first", "second", and the like, are used to describe various elements, regions, sections, etc. and are also not intended to be limiting. Like terms refer to like elements throughout the description.

As used herein, the terms "having", "containing", "including", "comprising" and the like are open ended terms that indicate the presence of stated elements or features, but

do not preclude additional elements or features. The articles “a”, “an” and “the” are intended to include the plural as well as the singular, unless the context clearly indicates otherwise.

It is to be understood that the features of the various embodiments described herein may be combined with each other, unless specifically noted otherwise.

Although specific embodiments have been illustrated and described herein, it will be appreciated by those of ordinary skill in the art that a variety of alternate and/or equivalent implementations may be substituted for the specific embodiments shown and described without departing from the scope of the present invention. This application is intended to cover any adaptations or variations of the specific embodiments discussed herein. Therefore, it is intended that this invention be limited only by the claims and the equivalents thereof.

What is claimed is:

1. A semiconductor module, comprising:

a semiconductor die;

a mold compound encasing the semiconductor die;

a plurality of terminals electrically connected to the semiconductor die and protruding out of the mold compound, wherein a first one of the terminals has a constricted region covered by the mold compound, wherein the mold compound has a recess or an opening near the constricted region of the first terminal; and

a coreless magnetic field sensor disposed in the recess or the opening of the mold compound and isolated from the first terminal by the mold compound, the coreless magnetic sensor configured to generate a signal in response to a magnetic field produced by current flowing in the constricted region of the first terminal, the magnitude of the signal being proportional to the amount of current flowing in the constricted region of the first terminal.

2. The semiconductor module of claim 1, wherein the coreless magnetic field sensor is a magnetoresistive sensor or a Hall sensor.

3. The semiconductor module of claim 1, wherein the constricted region of the first terminal comprises a tapered region over which the width of the first terminal narrows, wherein the recess of the mold compound is near the tapered region of the first terminal, wherein the coreless magnetic field sensor is a single-ended sensor disposed in the recess of the mold compound and comprises a single sensing element positioned adjacent one side of the tapered region, and wherein the single sensing element is isolated from the tapered region by the mold compound.

4. The semiconductor module of claim 1, wherein the constricted region of the first terminal comprises a tapered region over which the width of the first terminal narrows, wherein the recess of the mold compound is near the tapered region of the first terminal, wherein the coreless magnetic field sensor is a differential sensor disposed in the recess of the mold compound and comprises a first sensing element positioned adjacent a first side of the tapered region and a second sensing element positioned adjacent a second side of the tapered region opposite the first side, and wherein the first and second sensing elements are isolated from the tapered region by the mold compound.

5. The semiconductor module of claim 1, wherein the constricted region of the first terminal comprises a serpentine region, wherein the recess of the mold compound is near the serpentine region of the first terminal, wherein the coreless magnetic field sensor is a single-ended sensor disposed in the recess of the mold compound and comprises

a single sensing element positioned adjacent one side of the serpentine region, and wherein the single sensing element is isolated from the serpentine region by the mold compound.

6. The semiconductor module of claim 1, wherein the constricted region of the first terminal comprises a serpentine region, wherein the recess of the mold compound is near the serpentine region of the first terminal, wherein the coreless magnetic field sensor is a differential sensor disposed in the recess of the mold compound and comprises a first sensing element positioned adjacent a first side of the serpentine region and a second sensing element positioned adjacent a second side of the serpentine region opposite the first side, and wherein the first and second sensing elements are isolated from the serpentine region by the mold compound.

7. The semiconductor module of claim 1, wherein the constricted region of the first terminal comprises a region of the first terminal having an opening, wherein the opening of the mold compound is aligned with the opening in the first terminal, wherein the coreless magnetic field sensor is a single-ended sensor disposed in the opening of the mold compound and comprises a single sensing element positioned above or below the opening in the first terminal, and wherein the single sensing element is isolated from a sidewall of the opening in the first terminal by the mold compound.

8. The semiconductor module of claim 1, wherein the constricted region of the first terminal comprises a region of the first terminal having an opening, wherein the opening of the mold compound is aligned with the opening in the first terminal, wherein the coreless magnetic field sensor is a differential sensor disposed in the opening of the mold compound and comprises a first sensing element positioned above the opening in the first terminal and a second sensing element positioned below the opening in the first terminal, and wherein the first and second sensing elements are isolated from a sidewall of the opening in the first terminal by the mold compound.

9. The semiconductor module of claim 1, wherein the mold compound has a protrusion which covers more of the first terminal than other ones of the terminals protruding from a same side of the mold compound as the first terminal, and wherein the recess or the opening of the mold compound is formed in the protrusion.

10. The semiconductor module of claim 1, wherein the semiconductor die is a power semiconductor die, wherein the semiconductor module has double-sided cooling, and wherein the first terminal is an AC output terminal of the power semiconductor die.

11. A cooling system, comprising:

a plurality of individual semiconductor modules each comprising: a semiconductor die; a mold compound encasing the semiconductor die; a plurality of terminals electrically connected to the semiconductor die and protruding out of the mold compound, wherein a first one of the terminals has a constricted region covered by the mold compound, wherein the mold compound has a recess or an opening near the constricted region of the first terminal; and a coreless magnetic field sensor disposed in the recess or the opening of the mold compound and isolated from the first terminal by the mold compound, the coreless magnetic sensor configured to generate a signal in response to a magnetic field produced by current flowing in the constricted region of the first terminal, the magnitude of the signal being proportional to the amount of current flowing in the constricted region of the first terminal; and

13

a first lid joined to a second lid to form a sealed housing which includes the plurality of individual semiconductor modules and a cavity between the lids and the individual semiconductor modules for fluid flow via a plurality of ports formed in the first and/or second lid.

12. The cooling system of claim 11, wherein each coreless magnetic field sensor is a magnetoresistive sensor or a Hall sensor.

13. The cooling system of claim 11, wherein the constricted region of each first terminal comprises a tapered region over which the width of the first terminal narrows, wherein the recess of the mold compound is near the tapered region of the first terminal, wherein the coreless magnetic field sensor is a single-ended sensor disposed in the recess of the mold compound and comprises a single sensing element positioned adjacent one side of the tapered region, and wherein the single sensing element is isolated from the tapered region by the mold compound.

14. The cooling system of claim 11, wherein the constricted region of each first terminal comprises a tapered region over which the width of the first terminal narrows, wherein the recess of the mold compound is near the tapered region of the first terminal, wherein the coreless magnetic field sensor is a differential sensor disposed in the recess of the mold compound and comprises a first sensing element positioned adjacent a first side of the tapered region and a second sensing element positioned adjacent a second side of the tapered region opposite the first side, and wherein the first and second sensing elements are isolated from the tapered region by the mold compound.

15. The cooling system of claim 11, wherein the constricted region of each first terminal comprises a serpentine region, wherein the recess of the mold compound is near the serpentine region of the first terminal, wherein the coreless magnetic field sensor is a single-ended sensor disposed in the recess of the mold compound and comprises a single sensing element positioned adjacent one side of the serpentine region, and wherein the single sensing element is isolated from the serpentine region by the mold compound.

16. The cooling system of claim 11, wherein the constricted region of each first terminal comprises a serpentine region, wherein the recess of the mold compound is near the serpentine region of the first terminal, wherein the coreless magnetic field sensor is a differential sensor disposed in the recess of the mold compound and comprises a first sensing element positioned adjacent a first side of the serpentine region and a second sensing element positioned adjacent a second side of the serpentine region opposite the first side, and wherein the first and second sensing elements are isolated from the serpentine region by the mold compound.

17. The cooling system of claim 11, wherein the constricted region of each first terminal comprises a region of the first terminal having an opening, wherein the opening of the mold compound is aligned with the opening in the first terminal, wherein the coreless magnetic field sensor is a single-ended sensor disposed in the opening of the mold compound and comprises a single sensing element positioned above or below the opening in the first terminal, and wherein the single sensing element is isolated from a sidewall of the opening in the first terminal by the mold compound.

18. The cooling system of claim 11, wherein the constricted region of each first terminal comprises a region of the first terminal having an opening, wherein the opening of the mold compound is aligned with the opening in the first terminal, wherein the coreless magnetic field sensor is a differential sensor disposed in the opening of the mold

14

compound and comprises a first sensing element positioned above the opening in the first terminal and a second sensing element positioned below the opening in the first terminal, and wherein the first and second sensing elements are isolated from a sidewall of the opening in the first terminal by the mold compound.

19. The cooling system of claim 11, wherein the mold compound of each individual semiconductor module has a protrusion which covers more of the first terminal than other ones of the terminals protruding from a same side of the mold compound as the first terminal, and wherein the recess or the opening of the mold compound is formed in the protrusion.

20. The cooling system of claim 11, wherein each semiconductor die is a power semiconductor die, wherein each individual semiconductor module has double-sided cooling, and wherein each first terminal is an AC output terminal of the power semiconductor die.

21. A method of manufacturing a semiconductor module, the method comprising:

electrically connecting a plurality of terminals to a semiconductor die;

molding the plurality of terminals and the semiconductor die so that the semiconductor die is encased in a mold compound and the plurality of terminals protrude out of the mold compound, wherein a first one of the terminals has a constricted region covered by the mold compound, wherein the mold compound has a recess or an opening near the constricted region of the first terminal; and

placing a coreless magnetic field sensor in the recess or the opening of the mold compound, the coreless magnetic field sensor being isolated from the first terminal by the mold compound and configured to generate a signal in response to a magnetic field produced by current flowing in the constricted region of the first terminal, the magnitude of the signal being proportional to the amount of current flowing in the constricted region of the first terminal.

22. *A semiconductor module, comprising:*

a semiconductor die;

a mold compound encasing the semiconductor die;

a plurality of terminals electrically connected to the semiconductor die and protruding out of the mold compound, a first one of the terminals having a constricted region covered by the mold compound; and a recess formed in an exterior surface of the mold compound,

wherein the recess is aligned with the constricted region of the first terminal,

wherein the recess is shaped to receive a coreless magnetic field sensor,

wherein the mold compound isolates the constricted region of the first terminal from the recess.

23. *The semiconductor module of claim 22, wherein the constricted region of the first terminal comprises a tapered region over which the width of the first terminal narrows, wherein the recess is aligned with the tapered region of the first terminal, and wherein the tapered region of the first terminal is covered by the mold compound.*

24. *The semiconductor module of claim 22, wherein the constricted region of the first terminal comprises a serpentine region, wherein the recess is aligned with the serpentine region of the first terminal, and wherein the serpentine region of the first terminal is covered by the mold compound.*

25. *The semiconductor module of claim 22, wherein the mold compound has a protrusion which covers more of the*

15

first terminal than other ones of the terminals protruding from a same side of the mold compound as the first terminal, and wherein the recess is formed in the protrusion.

26. *The semiconductor module of claim 22, wherein the semiconductor die is a power semiconductor die, and wherein the first terminal is an AC output terminal of the power semiconductor die.*

27. *The semiconductor module of claim 22, further comprising metallized surfaces at opposite sides of the semiconductor module, and wherein each one of the metallized surfaces is exposed from the mold compound to provide double-sided cooling for the semiconductor module.*

28. *A semiconductor module, comprising:*

a semiconductor die;

a mold compound encasing the semiconductor die;

a plurality of terminals electrically connected to the semiconductor die and protruding out of the mold compound, a first one of the terminals having a constricted region covered by the mold compound; and an opening formed in the mold compound,

wherein the opening is aligned with the constricted region of the first terminal,

wherein the opening is shaped to receive a coreless magnetic field sensor,

16

wherein the mold compound isolates the constricted region of the first terminal from the opening.

29. *The semiconductor module of claim 28, wherein the constricted region of the first terminal comprises a region of the first terminal having an opening, wherein the opening formed in the mold compound is aligned with the opening in the first terminal, and wherein a sidewall of the opening in the first terminal is covered by the mold compound.*

30. *The semiconductor module of claim 28, wherein the mold compound has a protrusion which covers more of the first terminal than other ones of the terminals protruding from a same side of the mold compound as the first terminal, and wherein the opening is formed in the protrusion.*

31. *The semiconductor module of claim 28, wherein the semiconductor die is a power semiconductor die, and wherein the first terminal is an AC output terminal of the power semiconductor die.*

32. *The semiconductor module of claim 28, further comprising metallized surfaces at opposite sides of the semiconductor module, and wherein each one of the metallized surfaces is exposed from the mold compound to provide double-sided cooling for the semiconductor module.*

* * * * *