



US 20150138710A1

(19) **United States**

(12) **Patent Application Publication**  
**Mathew et al.**

(10) **Pub. No.: US 2015/0138710 A1**

(43) **Pub. Date: May 21, 2015**

(54) **PORTABLE COMPUTER DISPLAY STRUCTURES**

**Publication Classification**

(71) Applicant: **Apple Inc.**, Cupertino, CA (US)

(51) **Int. Cl.**  
**G06F 1/16** (2006.01)

(72) Inventors: **Dinesh C. Mathew**, Cupertino, CA (US); **Thomas W. Wilson, JR.**, Saratoga, CA (US); **Victor H. Yin**, Cupertino, CA (US); **Bryan W. Posner**, Cupertino, CA (US); **Chris Ligtenberg**, Cupertino, CA (US); **Brett W. Degner**, Cupertino, CA (US); **Peteris K. Augenbergs**, Cupertino, CA (US)

(52) **U.S. Cl.**  
CPC ..... **G06F 1/1637** (2013.01); **G06F 1/1658** (2013.01)

(21) Appl. No.: **14/520,079**

(57) **ABSTRACT**

(22) Filed: **Oct. 21, 2014**

An electronic device housing may have upper and lower portions that are attached with a hinge. At least one portion of the housing may have a rear planar surface and peripheral sidewalls having edges. A display module may be mounted in the housing. The display module may have glass layers such as a color filter glass layer and a thin-film transistor substrate. The color filter glass layer may serve as the outermost glass layer in the display module. The edges of the display module may be aligned with the edges of the peripheral housing sidewalls to create the appearance of a borderless display for the electronic device. The display module may be provided with an opening that allows a camera or other electronic components to receive light. Traces may be provided on the underside of the thin-film transistor substrate to serve as signal paths for the electrical components.

**Related U.S. Application Data**

(63) Continuation of application No. 13/786,344, filed on Mar. 5, 2013, now Pat. No. 8,866,989, which is a continuation of application No. 13/249,174, filed on Sep. 29, 2011, now Pat. No. 8,395,722, which is a continuation of application No. 12/483,206, filed on Jun. 11, 2009, now Pat. No. 8,456,586.

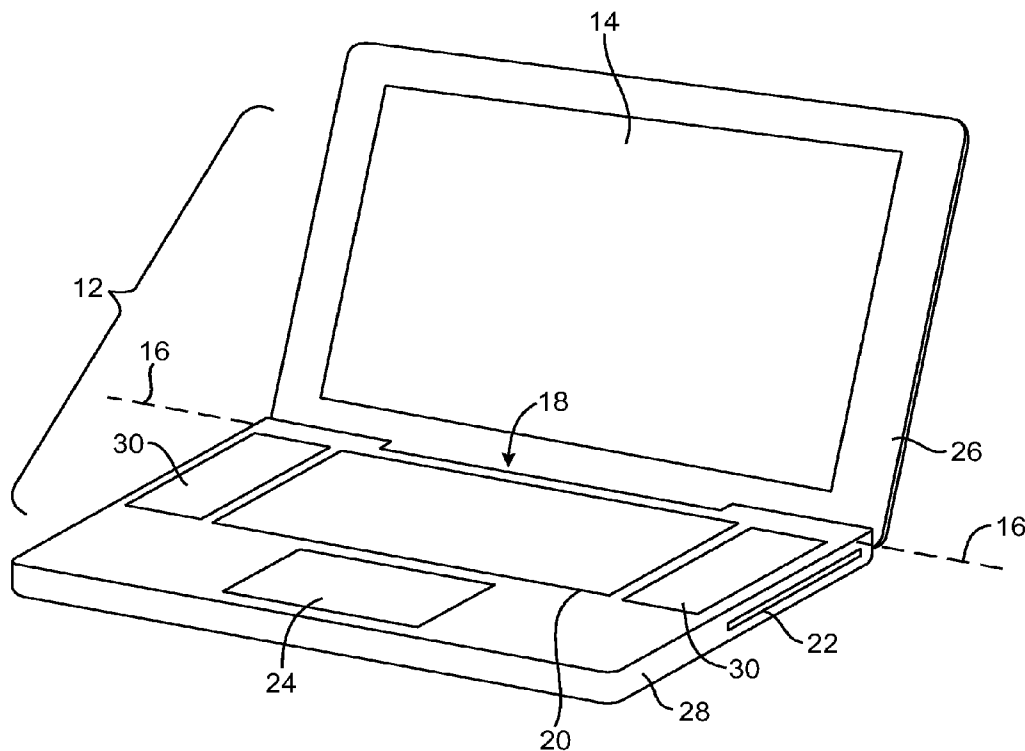

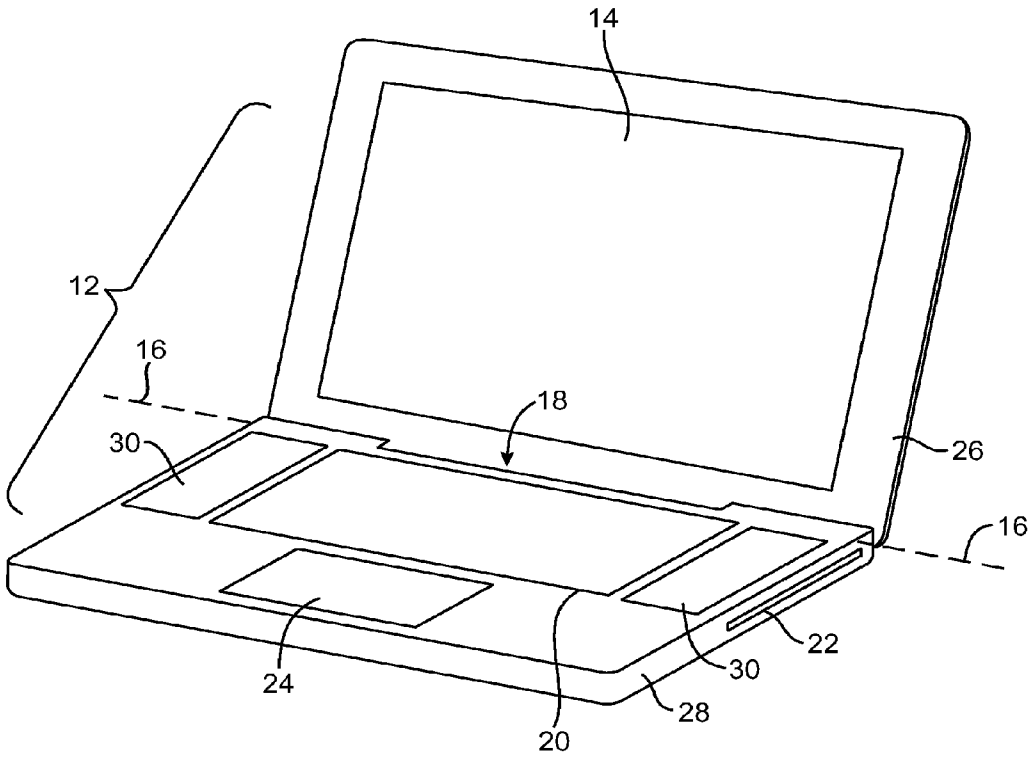
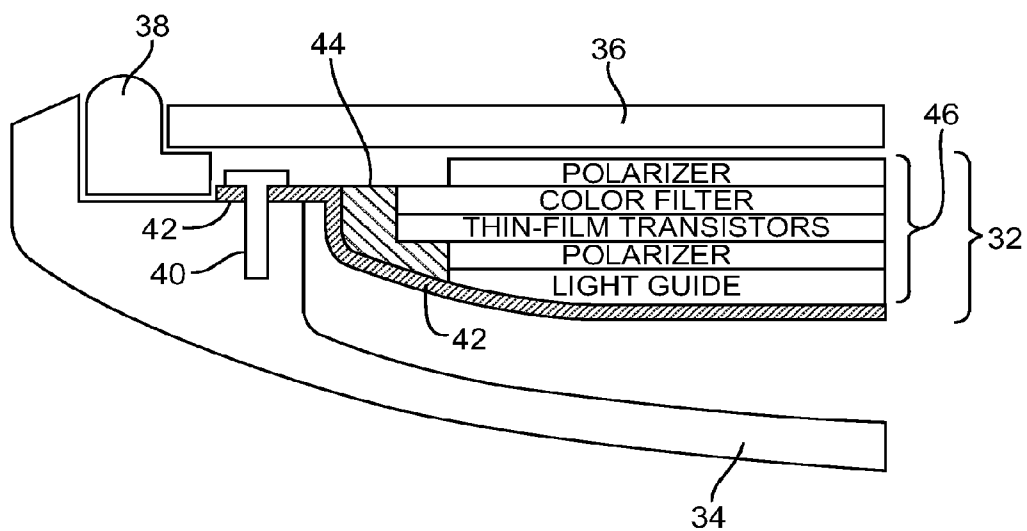
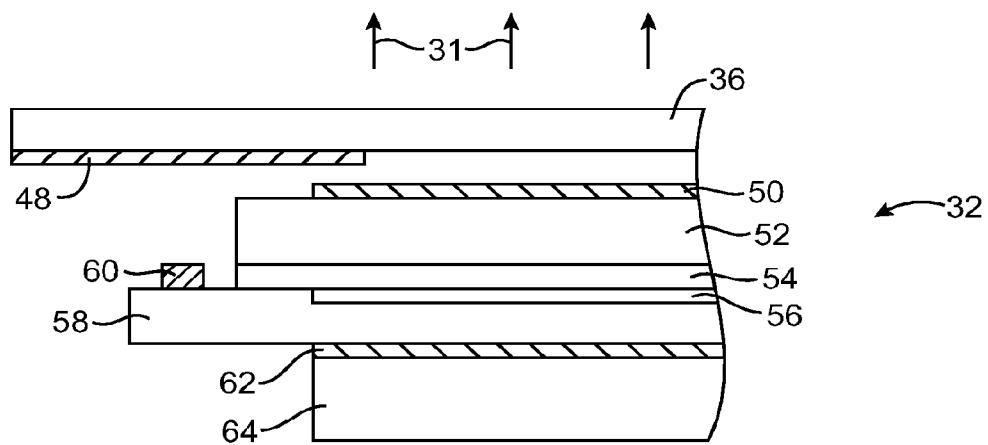

FIG. 1



(PRIOR ART)  
FIG. 2



(PRIOR ART)

FIG. 3

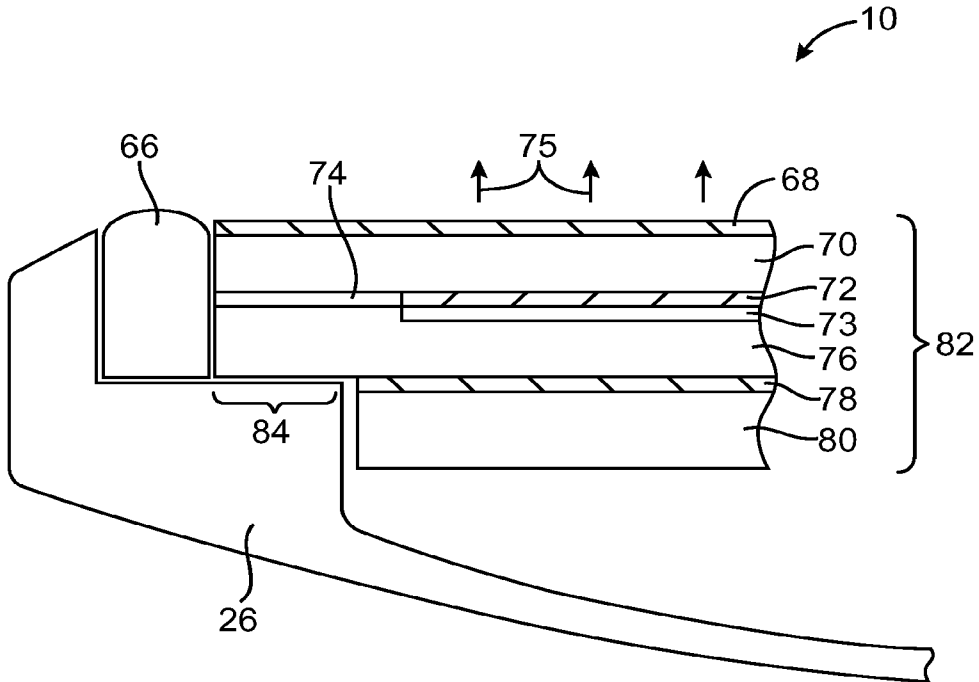

FIG. 4

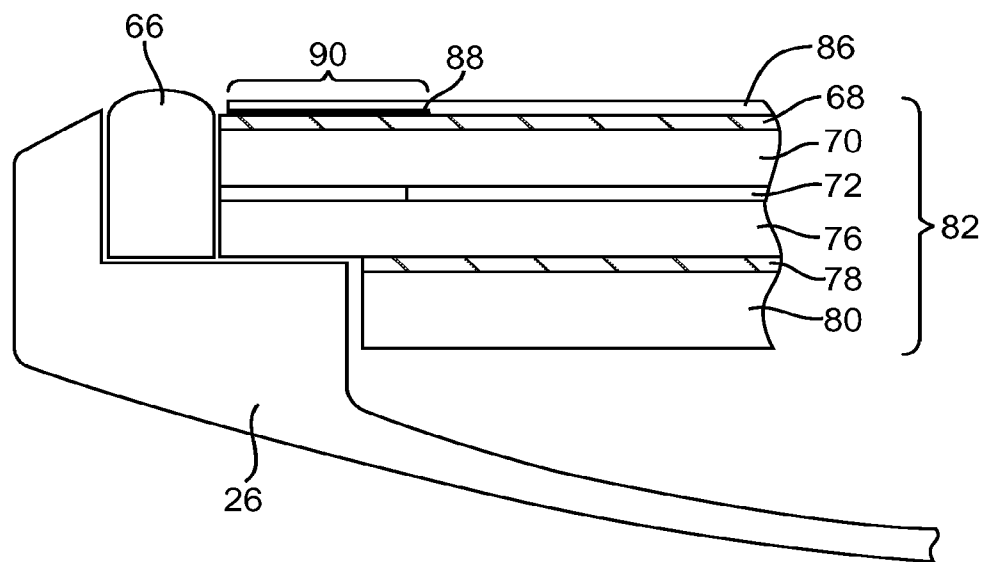

FIG. 5

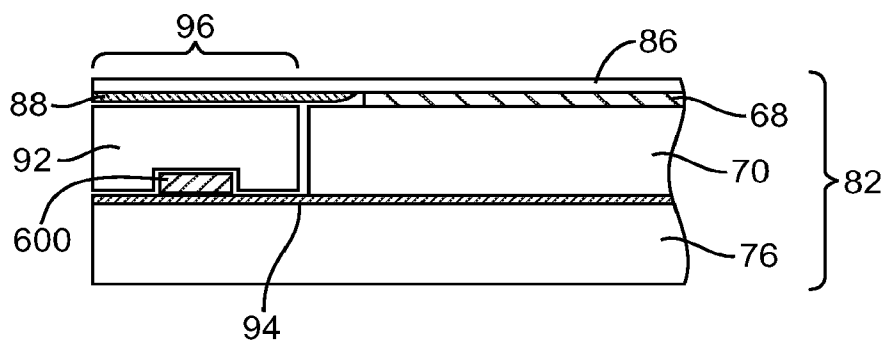

FIG. 6

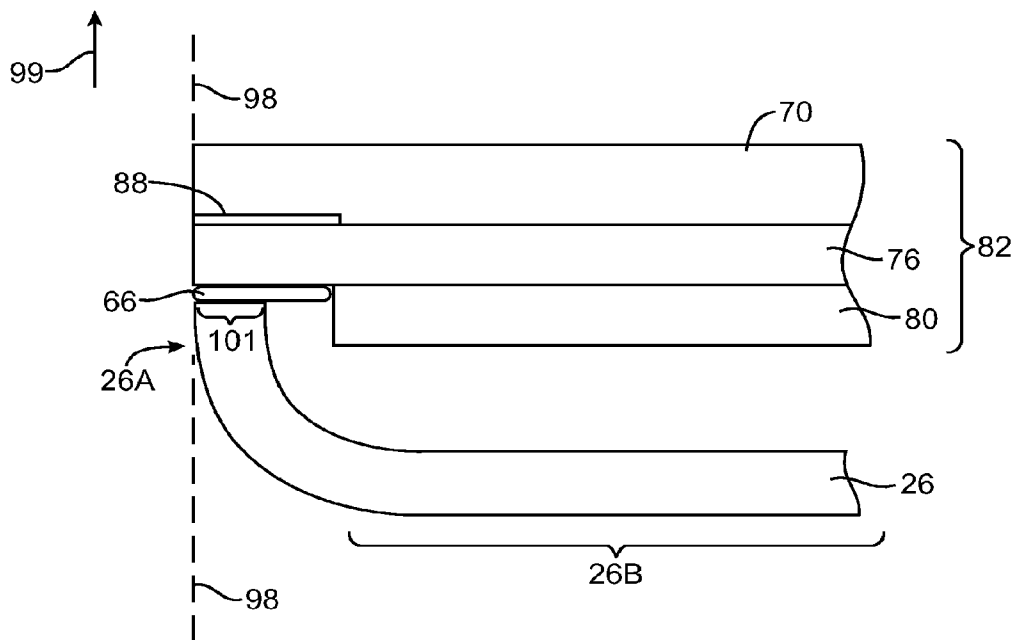

FIG. 7



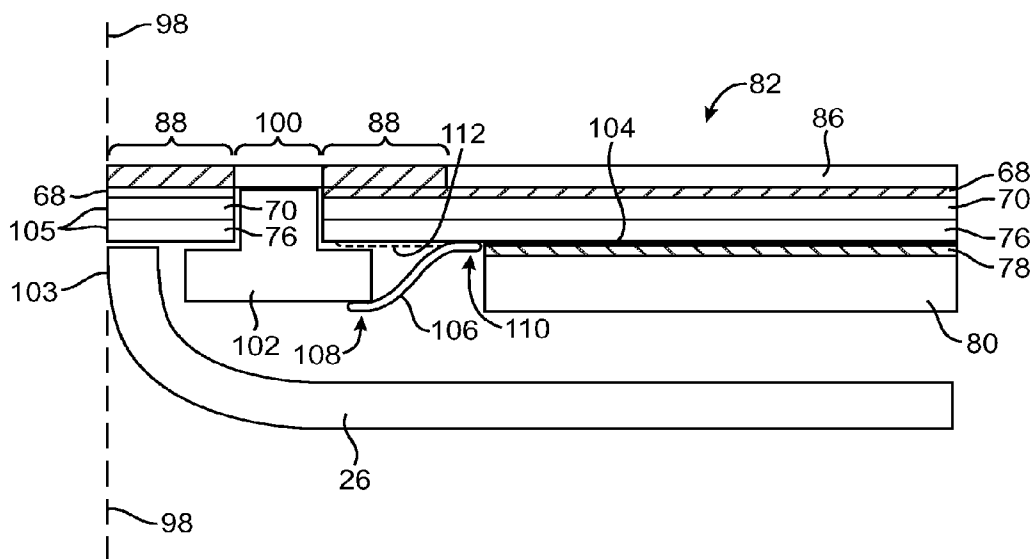

FIG. 8

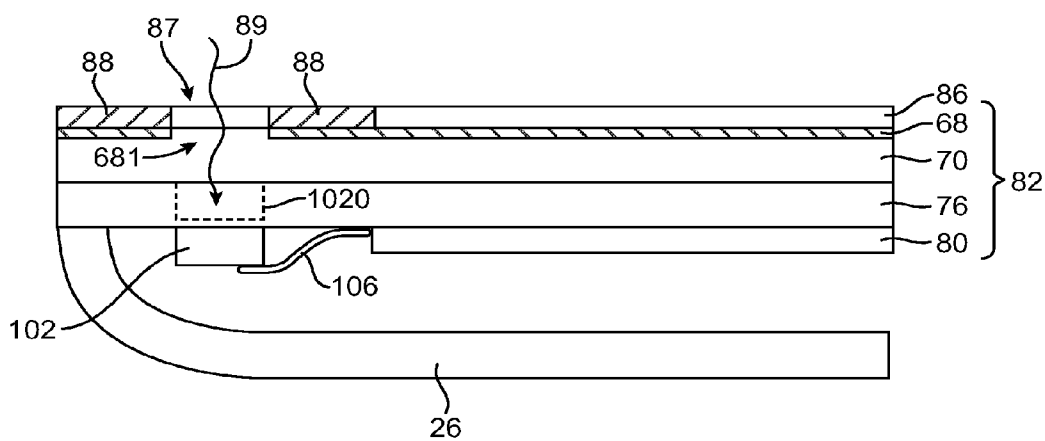

FIG. 9

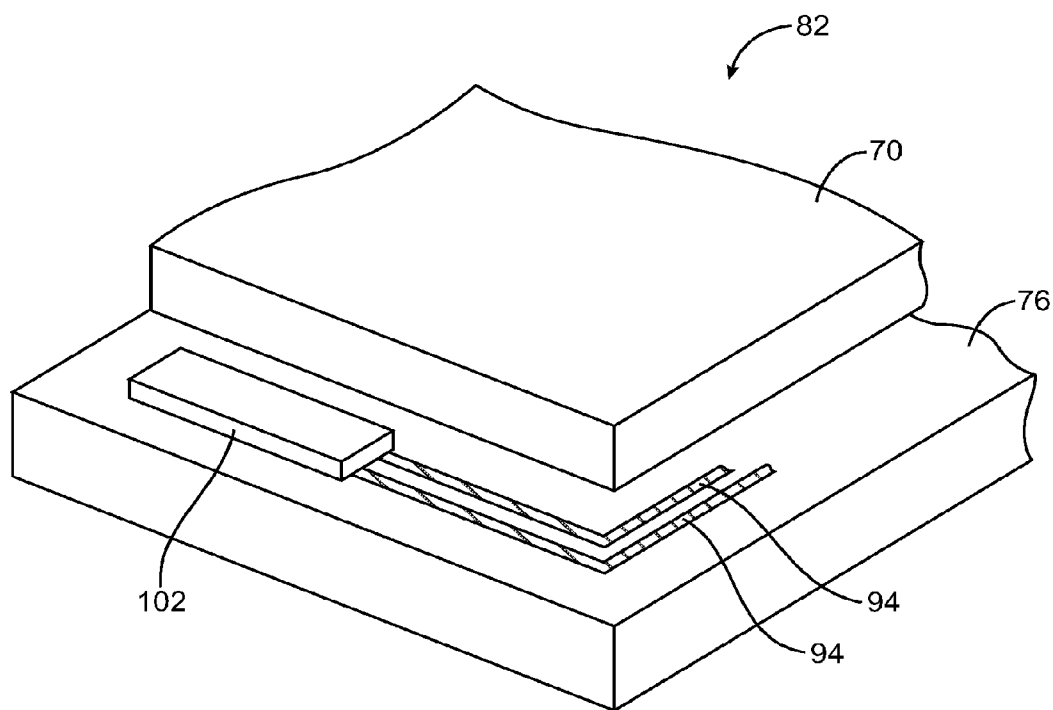

FIG. 10

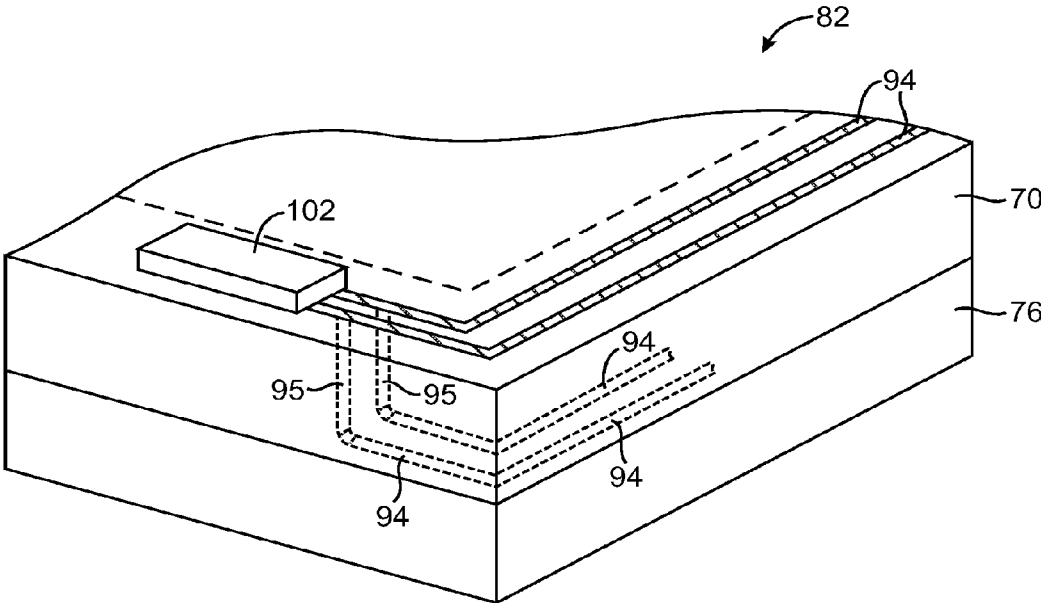

FIG. 11

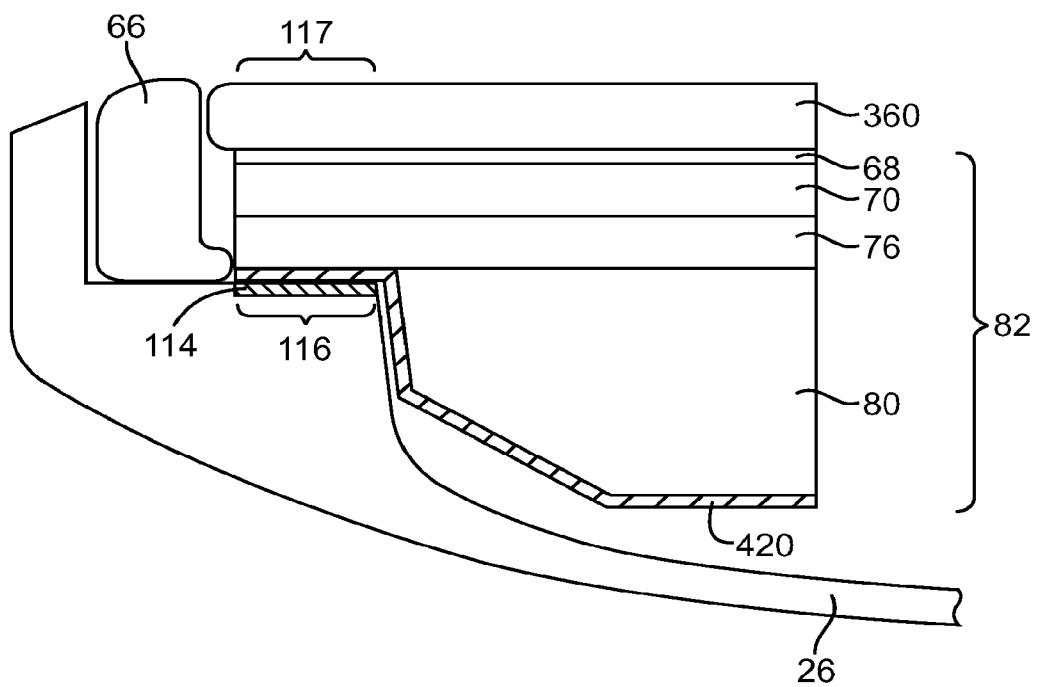

FIG. 12

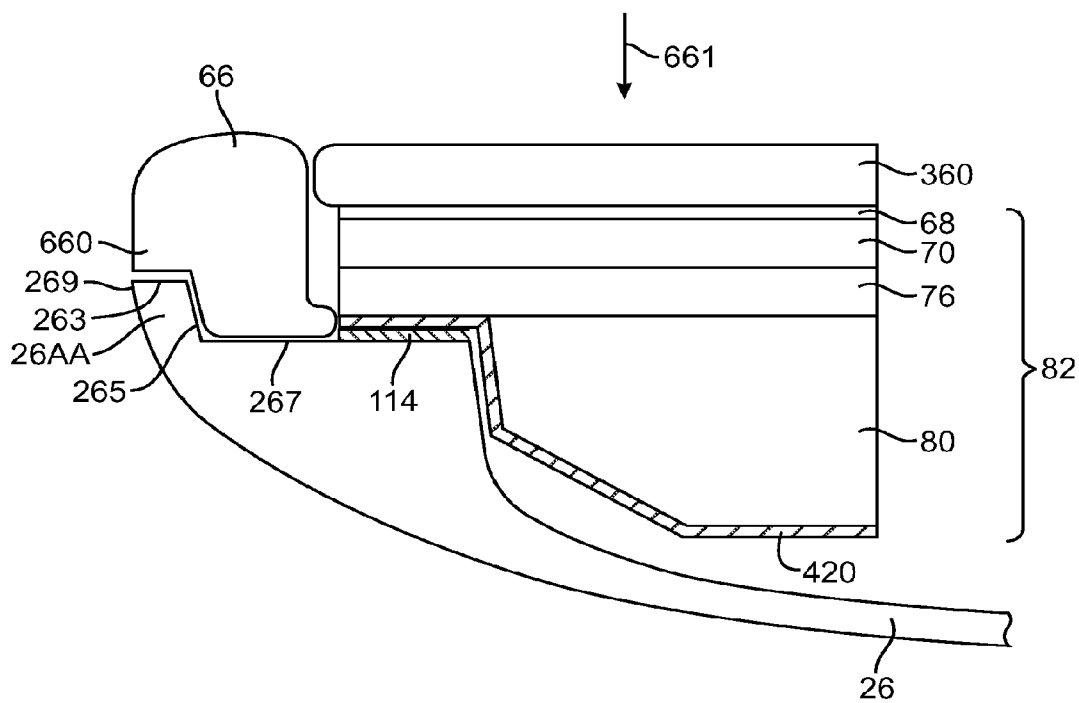

FIG. 13

## PORTABLE COMPUTER DISPLAY STRUCTURES

### CROSS-REFERENCE TO RELATED APPLICATIONS

**[0001]** This application is a continuation of U.S. patent application Ser. No. 13/786,344, filed Mar. 5, 2013, now U.S. Pat. No. 8,866,989; which is a continuation of U.S. patent application Ser. No. 13/249,174, filed Sep. 29, 2011, now U.S. Pat. No. 8,395,722; which is a continuation of U.S. patent application Ser. No. 12/483,206, filed Jun. 11, 2009, now U.S. Pat. No. 8,456,586, each of which is incorporated by reference in its entirety as if fully disclosed herein.

### TECHNICAL FIELD

**[0002]** This disclosure relates to electronic devices and, more particularly, to display structures for electronic devices such as portable computers.

### BACKGROUND

**[0003]** Portable computers typically have upper and lower housing portions that are connected by a hinge. The lower housing portion contains components such as printed circuit boards, disk drives, a keyboard, and a battery. The upper housing portion contains a display. When the computer is in an open configuration, the upper housing portion is vertical and the display is visible to the user of the portable computer. When the computer is closed, the upper housing lies flat against the lower housing. This protects the display and keyboard and allows the portable computer to be transported.

**[0004]** Portable computer displays typically contain fragile structures such as layers of glass and can be challenging to mount properly within the upper housing. If care is not taken, the display and the surrounding portions of the upper housing will be bulky and unsightly. At the same time, the elimination of certain structures in the display may result in display that is overly fragile. This could lead to damage to the display during normal use.

**[0005]** It would therefore be desirable to be able to provide improved display structures in electronic devices such as portable computers.

### SUMMARY

**[0006]** An electronic device such as a portable computer may have a housing. The housing may have upper and lower portions that are connected by a hinge. A display module may be mounted in a portion of the housing such as the upper housing portion.

**[0007]** The upper housing may have a planar rear surface and portions that extend upwards to form peripheral housing sidewalls. The housing sidewalls may extend around the display module to form a border or the display module may be mounted so that the outermost edges of the display module are aligned with the outermost edges of the peripheral housing sidewalls.

**[0008]** The display module may have a color filter glass layer and a thin-film transistor substrate layer. A layer of light-guide structures may be mounted under the thin-film transistor substrate layer. The peripheral edges of the color glass layer and the thin-film transistor substrate layer may extend laterally past the peripheral edges of the light guide structures to form an overhanging structure. The overhanging

structure may rest on the peripheral housing edges without any intervening display module chassis members.

**[0009]** An opening may be provided through the color filter and thin-film transistor substrate layers. A camera may receive light through the opening. Other electronic components may also be mounted within the housing of the electronic device such as ambient light sensors, proximity sensors, other sensors, indicator lights such as light-emitting diodes, input-output ports, buttons, microphones and speakers, antennas, etc. These electrical components can be electrically connected to traces formed on the underside of the thin-film transistor substrate layer or traces formed on other glass surfaces.

**[0010]** To block unsightly portions of the device from view around the periphery of the display module, the display module may be provided with an opaque border. The opaque border may be formed from a peripheral ring of black ink. The black ink may be formed on a glass layer such as the color filter glass. A polymer film that includes a black ink may also be used in forming the opaque border.

**[0011]** If desired, the display module may contain no cover glass layers. In this type of configuration, the outermost glass layer in the display module may be formed from the color filter glass. The polymer film layer and other layers such as polarizing layers may be formed on top of the color filter glass layer.

**[0012]** The display module may contain integrated circuits such as display driver circuits. A display driver circuit may be mounted on the thin-film transistor substrate. A support structure such as a glass member with a recess to accommodate the driver circuit may be placed over the driver circuit. The support structure may support coating layers such as the polymer film layer with the opaque border.

**[0013]** Further features of the invention, its nature and various advantages will be more apparent from the accompanying drawings and the following detailed description of the preferred embodiments.

### BRIEF DESCRIPTION OF THE DRAWINGS

**[0014]** FIG. 1 is a perspective view of an illustrative portable computer with display structures in accordance with an embodiment of the present invention.

**[0015]** FIG. 2 is a cross-sectional side view of a conventional liquid crystal display (LCD) module in a portable computer display housing.

**[0016]** FIG. 3 is a cross-sectional side view of an edge portion of a conventional LCD module.

**[0017]** FIG. 4 is a cross-sectional side view of an illustrative display module in an electronic device such as a portable computer in accordance with an embodiment of the present invention.

**[0018]** FIG. 5 is a cross-sectional side view of an illustrative display module with a thin plastic coating that has a border region that is coated with an opaque ink in accordance with an embodiment of the present invention.

**[0019]** FIG. 6 is a cross-sectional side view of a portion of an illustrative display module for an electronic device such as a portable computer in accordance with an embodiment of the present invention.

**[0020]** FIG. 7 is a cross-sectional side view of a portion of an illustrative display module that has extending portions that rest on housing walls in an electronic device such as a portable computer in accordance with an embodiment of the present invention.

[0021] FIG. 8 is a cross-sectional view of an illustrative electronic device showing how components such as a camera module and antenna may be formed through an opening in display module layers such as a color filter glass layer and thin-film transistor substrate layer in accordance with an embodiment of the present invention.

[0022] FIG. 9 is a cross-sectional side view of an illustrative electronic device showing how a camera module or other electronic component may be mounted to the underside of a layer of glass in a display module and how the component may operate through a clear window region in the glass in accordance with an embodiment of the present invention.

[0023] FIG. 10 is a perspective view of a portion of a display module in which an electrical component has been mounted to an upper surface of a thin-film transistor substrate layer and in which conductive traces have been formed that route signals on the upper surface of the thin-film transistor substrate outside of the active area of the display module in accordance with an embodiment of the present invention.

[0024] FIG. 11 is a perspective view of a portion of a display module in which an electrical component has been mounted to an upper surface of a color filter glass layer and in which conductive traces have been formed that route signals outside of the active area of the display module in accordance with an embodiment of the present invention.

[0025] FIG. 12 is a cross-sectional side view of a portion of a display module showing how edge portions of layers of glass such as a cover glass layer, color filter, and thin-film transistor substrate layer may rest on a housing wall ledge above a metal chassis portion in accordance with an embodiment of the present invention.

[0026] FIG. 13 is a cross-sectional side view of a portion of a display module in which an elastomeric trim structure has been used to cover the uppermost surfaces of a housing wall in accordance with an embodiment of the present invention.

#### DETAILED DESCRIPTION

[0027] An illustrative electronic device such as a portable computer in which display structures may be provided is shown in FIG. 1. As shown in FIG. 1, portable computer 10 may have housing 12. Housing 12, which is sometimes referred to as a case, may be formed from one or more individual structures. For example, housing 12 may have a main structural support member that is formed from a solid block of machined aluminum or other suitable metal. One or more additional structures may be connected to the housing 12. These structures may include, for example, internal frame members, external coverings such as sheets of metal, etc. Housing 12 and its associated components may, in general, be formed from any suitable materials such as plastic, ceramics, metal, glass, etc. An advantage of forming housing 12 at least partly from metal is that metal is durable and attractive in appearance. Metals such as aluminum may be anodized to form an insulating oxide coating.

[0028] Housing 12 may have an upper portion 26 and a lower portion 28. Lower portion 28 may be referred to as the base or main unit of computer 10 and may contain components such as a hard disk drive, battery, and main logic board. Upper portion 26, which is sometimes referred to as a cover, lid, or display housing, may rotate relative to lower portion 28 about rotational axis 16. Portion 18 of computer 10 may contain a hinge and associated clutch structures and is sometimes referred to as a clutch barrel.

[0029] Lower housing portion 28 may have a slot such as slot 22 through which optical disks may be loaded into an optical disk drive. Lower housing portion may also have a touchpad such as touchpad 24 and may have keys 20. If desired, additional components may be mounted to upper and lower housing portions 26 and 28. For example, upper and lower housing portions 26 and 28 may have ports to which cables can be connected (e.g., universal serial bus ports, an Ethernet port, a Firewire port, audio jacks, card slots, etc.). Buttons and other controls may also be mounted to housing 12. Speaker openings such as speaker openings 30 may be formed in lower housing portion 28 by creating an array of small openings (perforations) in the surface of housing 12.

[0030] A display such as display 14 may be mounted within upper housing portion 26. Display 14 may be, for example, a liquid crystal display (LCD), organic light emitting diode (OLED) display, or plasma display (as examples). Display 14 may contain a number of layers of material. These layers may include, for example, layers of optically transparent glass. Layers of plastic and optical adhesive may also be incorporated into display 14. In a liquid crystal display, layers of polarizer, light diffusing elements and light guides for back-light structures, a liquid crystal layer, and a thin-film transistor array that drives the image pixels in the display may be incorporated into the display. The collection of material layers and associated support structures that are used to form display 14 are sometimes referred to as a module. Display 14 may therefore sometimes be referred to as a display module.

[0031] Computer 10 may have input-output components such as touch pad 24. Touch pad 24 may include a touch sensitive surface that allows a user of computer 10 to control computer 10 using touch-based commands (gestures). A portion of touchpad 24 may be depressed by the user when the user desires to “click” on a displayed item on screen 14.

[0032] A cross-sectional side view of a conventional liquid crystal display (LCD) display module is shown in FIG. 2. As shown in FIG. 2, display module 32 may have display structures 46 such as an upper polarizer layer, a color filter, a thin-film transistor glass layer, a lower polarizer, and a layer of light-guide structures such as light guides and diffuser layers. Display module 32 may also have a plastic chassis member such as plastic chassis member 44 and a metal chassis member such as metal chassis member 42 into which the layers of glass and other display module structures may be mounted. Cover glass 36 may be placed on top of structures 46.

[0033] Metal chassis member 42 may have a tab with a hole through which screw 40 passes. Screw 40 may be screwed into a threaded hole in housing 34. In the arrangement of FIG. 2, housing 34 is formed of aluminum. The presence of the extending tab portion of chassis 42 allows module 32 to be firmly secured in housing 34, but adds undesirable width to the perimeter of display module 32.

[0034] Elastomeric gasket 38 is used to form a cushioned interface between cover glass layer 36 and housing 34. This helps to prevent damage to cover glass layer 36. Cover glass 36 is formed from clear glass and helps to protect layers 46 of LCD module 32 from damage, but adds undesirable thickness.

[0035] Another cross-sectional view of a conventional liquid crystal display module is shown in FIG. 3. As shown in FIG. 3, display module 32 may have polarizers such as upper polarizer layer 50 and lower polarizer 62. Light guide structure 64 may provide backlight for module 32. The light from



structure **64** passes through the display pixels of module **32** and exits display module **32** in direction **31**.

**[0036]** Color filter glass layer **52**, liquid crystal layer **54**, and thin-film transistor (TFT) glass layer **58** are interposed between polarizer layers **50** and **62**.

**[0037]** The polarization of individual pixels of liquid crystal material in liquid crystal layer **54** interacts with the polarizing effects of layers **50** and **62** to determine which display pixels block light and which pixels allow light to pass. Color filter glass layer **52** contains an array of colored filters that provide display **32** with the ability to represent different colors. The polarization of liquid crystal material in liquid crystal layer **54** is controlled electrically by thin-film transistor array **56**. Thin-film transistors in array **56** are formed on the upper surface of thin-film transistor (TFT) glass layer **58**.

**[0038]** Thin-film transistors **56** are controlled by drivers contained in driver circuit **60**. Color filter layer **52** is horizontally (laterally) recessed with respect to TFT layer **58** to form a ledge on which driver circuit **60** is mounted.

**[0039]** In a typical display module, there may be a number of driver chips such as circuit **60** that are mounted around the periphery of the display. Conductive traces on the upper surface of TFT layer **58** interconnect driver circuit **60** with thin-film transistors **56**.

**[0040]** In conventional arrangements of the type shown in FIG. 3, black ink **48** is placed on the underside of cover glass **36** around the periphery of the display. This creates an opaque region that blocks inactive peripheral portions of display module **32** from view. Black ink **48** can also hide mounting structures such as screw **40** of FIG. 2 from view. Display glass **36** may help provide structural support to the display housing of the portable computer in which display module **32** is mounted, but the presence of glass **36** can add a non-negligible amount of extra thickness and weight to a display.

**[0041]** Display **14** in device **10** (FIG. 1) may be implemented using a display module with structural enhancements. A display module with illustrative enhancements is shown in FIG. 4.

**[0042]** FIG. 4 shows a cross-sectional side view of a portion of upper housing **26** of device **10** (FIG. 1) in which display module **82** has been mounted. Upper housing **26** may, for example, be formed from machined aluminum. Elastomeric gasket **66** may be used to provide a soft interface between potentially fragile glass layers in module **82** and housing **26**.

**[0043]** Display module **82** may produce an image using any suitable display technology (e.g., light-emitting diodes such as an array of organic light-emitting diodes, liquid crystal display pixels, plasma-based pixels, etc.). An arrangement in which display module **82** is based on liquid crystal display (LCD) technology is sometimes described herein as an example. The use of LCD structures in display module **82** is, however, merely illustrative. Display module **82** may, in general, be formed from any suitable type of display structures.

**[0044]** As shown in FIG. 4, display module **82** may have an upper polarizer layer **68** and a lower polarizer layer **78**. Light guide structure layer **80** may provide backlight for module **82**. Light-guide structure layer **80** may include light guide structures and diffuser layers. These structures may help route light from a light-emitting diode light source or other backlight source through the layers of module **82** in direction **75**.

**[0045]** Thin-film transistor substrate glass layer **76** may contain thin-film transistors in array **73**. Color filter glass layer **70** may contain an array of optical filters of different colors to provide display module **82** with the ability to display

color images. Color filter layer **70** may be formed from glass into which dye of different colors has been impregnated, from a glass layer coated with a pattern of colored dye, from a glass or plastic layer that is covered with a pattern of thin colored filter structures (e.g., filters formed from polymer or glass containing dye), or any other suitable color filter structures. Liquid crystal layer **72** may be controlled by the electric fields produced by the thin-film transistors of array **73**.

**[0046]** As shown in FIG. 4, the layer of cover glass that is present in conventional display modules is not present in display module **82** and device **10**. Rather, color filter layer **70** serves as the uppermost glass layer in module **82** and device **10**. To ensure that module **82** is sufficiently robust, color filter layer **70** may be thickened or may be stiffened using support structures on the underside of display module **82**. Color filter layer **70** may be formed of a durable clear layer (e.g., a strong glass or plastic) that resists damage from contact. Anti-scratch coatings may also be provided on the surface of color filter layer **70** (e.g., as part of polarizer layer **68** or above polarizer layer **68**).

**[0047]** To hide the peripheral portions of display module **82** that lie along the outer edges of display housing **26** from view, an opaque material such as black ink layer **74** may be incorporated around the periphery of display module **82** to form a black border. Opaque layer **74** may be formed on the underside of color filter layer **70** or on the upper surface of thin-film transistor glass layer **76** (as examples).

**[0048]** With the arrangement of FIG. 4, color filter layer **70** and thin-film transistor layer **76** have been extended outwardly (in the leftward direction in the orientation of FIG. 4) so as to form an overhanging portion **84** that is supported by the matching ledge in housing **26**. If desired, only color filter layer **70** may be extended in this way (e.g., so that the overhanging portion of layer **70** rests on the ledge formed by housing **26**). In this type of arrangement, the thin-film transistor layer may extend only as far as light-guide structures **80** of FIG. 4. If desired, portions of gasket **66** may be interposed between module **82** and housing **26** in region **84**.

**[0049]** If desired, black ink layer **74** may be formed above color filter glass layer **70**. As shown in FIG. 5, for example, a layer of material such as layer **86** may be provided on the upper surface of color filter glass layer **70**. Layer **86** may, for example, be a layer of plastic such as polyester. Ink layer **88** may be printed on the underside of plastic layer **86** in region **90**. When plastic layer **86** is attached to the surface of display module **82**, the ink in region **90** will block unsightly internal components in housing **26** and module **82** from view by a user. Layers in module **82** may be interconnected using fastening mechanisms and adhesive (e.g., optically clear adhesive such as epoxy).

**[0050]** Integrated circuits such as display driver circuits may be incorporated into display module **82** to drive display signals into thin-film transistor array **73** (FIG. 4). If desired, circuits such as these or other circuits may be mounted on the upper surface of thin-film transistor substrate layer **76** under a support member. This type of configuration is shown in FIG. 6. As shown in FIG. 6, circuit **600** may be mounted under support **92**. Support **92** may have a recessed portion that accommodates the thickness of circuit **600**. Circuit **600** may be a display driver circuit or other suitable electrical component for device **10**.

**[0051]** With arrangements of the type shown in FIG. 6, support **92** has about the same thickness as color filter glass layer **70** and straddles circuit **600**. This allows support struc-

ture **92** to support layer **86** in peripheral region **96**. Support **92** may be formed from glass, plastic, metal, or other suitable materials. If desired, color filter glass layer **70** may be provided with a recess on its underside that accommodates circuit **600**. In this situation, a separate support structure need not be used.

**[0052]** Conductive traces, thin-film transistors, and other circuitry **94** may be formed on the upper surface of thin-film transistor substrate **76**. When circuit **600** is mounted on substrate **76**, the traces on the surface of substrate layer **76** may convey signals (e.g., display driver signals) to the thin-film transistors on layer **76**. Other signals may also be routed using these traces. For example, the traces on layer **76** may be used to route radio-frequency signals, touch sensor signals, signals associated with status indicator lights or other output devices, proximity sensor signals, etc.

**[0053]** If desired, housing **26** may be formed directly under the edge of the display module layers. This type of arrangement is shown in FIG. 7. As shown in FIG. 7, display module **82** may have an upper layer formed from color filter **70**. Color filter layer **70** may be formed from glass or other suitable material and includes a pattern of colored pixel-sized filters. A band of opaque material such as ink **88** may be formed on the underside of the periphery of color filter layer **70**. Ink **88** may hide inactive portions of display module **82** and other structures such as housing **26** from view through the upper surface of display module.

**[0054]** An elastomeric member such as gasket **66** may be used to provide an interface between housing **26** and the underside of thin-film transistor substrate layer **76**. Gasket **66** may help prevent glass structures and other structures in display module **70** from being scratched by housing **26** (e.g., when housing **26** is formed from aluminum or other hard materials). If desired, gasket **66** may be omitted or gaskets of other shapes may be used.

**[0055]** Light-guide structure **80** may be located under thin-film transistor layer **76**. Structure **80** may contain light guides for directing light through the display, diffuser layers for diffusing light, etc. Polarizer layers may be incorporated into display module **82** above cover glass layer **70** and below thin-film transistor layer **76**.

**[0056]** With arrangements of the type shown in FIG. 7, housing **26** may have housing walls that form a substantially planar rear portion with a substantially planar exterior rear surface. In the example of FIG. 7, this is shown by planar rear portion **26B**. Portions of the housing sidewalls may also protrude vertically upward (in the orientation of FIG. 7). For example, at least some of housing wall portions **26A** around the periphery of housing **26** may extend vertically upward in direction **99**. At the uppermost portion of peripheral housing walls **26A**, housing wall **26A** may be provided with a flat horizontal upper surface **101** that supports the overhanging lower surface of color filter layer **70** and/or thin-film transistor substrate layer **76** (with optional intervening gasket **66**). Because the outermost edge of display module **82** (i.e., the leftmost edges of layers **70** and **76**) are laterally (horizontally) aligned with the outermost edge portions of housing walls **26A** along vertical axis **98**, the display module may have the appearance of being borderless. This configuration also allows the active region of the display to be extended close to the outer edge of housing **26**.

**[0057]** Electronic device may contain electrical components such as integrated circuits, antennas, and cameras, etc. Traces may be formed on the underside of thin-film transistor

layer **76** (i.e., the opposite surface of layer **76** from the surface on which the thin-film transistors are formed). These traces may be used to help route signals to and from the electrical components. Openings may also be formed in the layers of display module **82** to accommodate components. For example, a vertical hole may be formed through color filter layer **82** and thin-film transistor layer **76**. This hole may be used to receive light for a camera or to accommodate other electronic components such as a status light indicator (i.e., a status light-emitting diode), a speaker, a microphone, a button, or other suitable electrical component.

**[0058]** FIG. 8 is a cross-sectional side view of a display module that incorporates features such as these. As shown in FIG. 8, display module **82** may have color filter glass **70** and thin-film transistor glass layer **76**. Upper polarizer **68** may be located above color filter glass **70**. Lower polarizer **78** may be located below thin-film transistor glass layer **76**. A cylindrical hole or other suitable opening such as opening **100** may be formed through color filter glass **70** and thin-film transistor glass layer **76**. This hole may be used to accommodate electrical component **102**. Electronic component **102** may be a camera, a proximity sensor, an ambient light sensor, an antenna, a microphone, a speaker, a digital data port, an audio jack or other analog port, a button, a touch sensor, etc. Arrangements in which component **102** is a camera are sometimes described herein as an example.

**[0059]** Opaque layer **88** may be formed by printing black ink or other suitable opaque material on a plastic layer such as layer **86** that is attached to the upper surface of polarizer **68** and color filter **70** (as an example). Opaque layer **88** may be formed in a border around the periphery of display module **82** (i.e., along the outermost edge of housing **26**). To prevent interference with camera **102** (or other electronic component **102**), it may be desirable omit black ink in the region above opening **100**.

**[0060]** As with the example of FIG. 7, the illustrative display module configuration of FIG. 8 is mounted in housing **26** so that the outermost peripheral edges of housing **26** (e.g., edge **103**) and the outermost edges of filter layer **70** and thin-film transistor layer **76** (e.g., edges **105**) are laterally aligned (i.e., outermost edges **103** of housing **26** and the outermost edges **105** of display module **82** are horizontally aligned with the same vertical axis—axis **98**—in the cross-sectional view of FIG. 8). As with the FIG. 7 arrangement, this edge alignment can be maintained around the entire periphery of display module **82**, providing device **10** with a borderless appearance (i.e., with no visible border-shaped housing structures surrounding the display). If desired, other configurations such as the configuration of FIG. 5 may be used (e.g., configurations in which housing **26** has vertical sidewalls within which module **82** is mounted to create a visible housing border that surrounds module **82** on all four of its outer edges).

**[0061]** Camera **102** contains a digital sensor that generates image data. A flex circuit cable or other data path may be used to convey camera data from camera **102** to storage and processing circuitry in device **10**. The upper surface of thin-film transistor layer **76** contains an array of thin-film transistors and associated conductive traces. As shown in the cross-sectional view of FIG. 8, the lower surface of thin-film transistor layer **76** may be provided with traces **104**. Flex circuit cable **106** may have contact pads that are electrically connected to camera **102** at end **108** and contact pads that are electrically connected to traces **104** at end **110**. Using this

type of arrangement, camera data can be conveyed using traces **104**. This may help reduce or eliminate the need for additional cables in device **10**.

[0062] Camera **102** is merely an example of an electrical component for which signals may be routed through under-side traces on thin-film transistor substrate **76**. In general, any electrical component that produces or receives electrical signals in device **10** can be electrically connected to traces **104**. The use of traces **104** on layer **76** can reduce the number of cables used to route signals between these electrical components and processing circuitry in device **10** (i.e., circuits on a main logic board and other storage and processing circuitry in device **10**).

[0063] As shown by dashed line **112**, an antenna may be formed from some of the traces **104** on layer **76**. Antenna **112** may be, for example, an antenna for a local wireless network or a cellular telephone.

[0064] Traces **104** may be formed from any suitable conductor. In typical configurations for display module **82**, back-lighting is provided by structures **80**. It is therefore typically desirable to form traces **104** from transparent conductive materials such as indium-tin oxide. This is, however, merely one illustrative material that may be used for traces **104**. In general, any suitable conductor may be used. Moreover, it is not necessary to form traces **104** on the underside of thin-film transistor substrate layer **76**. Traces **104** may be formed on other glass layers in module **82**. For example, signal paths for camera signals, antenna signals, or other electrical component signals can be formed from indium-tin oxide patterns on the surface of a cover glass layer, a color filter layer (e.g., layer **70**), a glass layer in structures **80**, or other suitable display module layers.

[0065] As shown in the cross-sectional view of FIG. **9**, ink border **88** may be provided with opening **87** and polarizer **68** may be provided with opening **681**. This allows light to pass to and from the lower layers of display module **82**, without forming holes in thin-film transistor substrate layer **76** and color filter glass layer **70**. Even though no hole is formed in layers **70** and **76** (in the FIG. **9** example), light for electronic component **102** may still pass through openings **87** and **681** and may pass through the clear portions of layers **70** and **76** under openings **87** and **681**. Electronic component **102** may be a camera, sensor, or other suitable electronic component. Component **102** may receive light along path **89**. Component **102** may be mounted to the underside of thin-film-transistor layer or, as indicated by dashed line **1020**, may be mounted to the underside of color filter glass layer **70**.

[0066] The perspective view of FIG. **10** shows how an electrical component **102** (e.g., a camera, sensor, antenna, button, or any other suitable component) may be mounted to the upper surface of thin-film transistor substrate layer **76** outside of the active area of display module **82**. The active area of display module **82** may be aligned with color filter **70** or may have an area that is somewhat smaller than the surface area of color filter **70** (i.e., in alignment with the thin-film transistor array on thin-film transistor substrate **76**). As shown in FIG. **10**, conductive traces **94** may also be formed outside of the active area to route signals to and from electrical component **102**.

[0067] In the illustrative arrangement of FIG. **11**, electrical component **102** has been mounted to an upper surface of color filter glass layer **70**. Conductive traces **94** that lie outside of the active area of display module **82** may be used to convey signals to and from electrical component **102**. Conductive

traces **94** may be formed on the upper surface of color filter glass layer **70** (e.g., under a polymer coating layer or other protective layer) or may be formed on the lower surface of color filter glass layer **70** or the upper surface layer of thin-film transistor substrate layer **76**. Vias **95** may be formed through color filter glass layer **70** to interconnect component **102** and conductive traces that have been formed lower in the display module stack. Vias may also be formed through other glass layers such as thin-film transistor substrate layer **76** (e.g., to use traces on the lower surface of the thin-film transistor substrate layer to route signals in module **82**).

[0068] FIG. **12** is a cross-sectional side view of a portion of a display module showing how layers of glass such as cover glass layer **360**, color filter glass **70**, and thin-film transistor substrate layer **76** may each have peripheral edge portions **117** that rest on housing wall ledge portion **116** of housing **26**. Module **82** may be provided with a chassis such as metal chassis member **420**. A laterally extending edge portion of member **420** may also rest on ledge **116** below cover glass **360**, color filter **70**, and thin-film transistor substrate **76**. Adhesive **114** may be used to secure these layers to housing **26**.

[0069] FIG. **13** shows an arrangement of the type shown in FIG. **12** in which elastomeric trim **66** (sometimes referred to as a gasket) has extending portion **660**. Extending portion **660** covers portion **26AA** of housing **26** and all of the exposed upper surfaces of housing **26** (i.e., all of surfaces **263**, **265**, and **267**, including the portions of surface **263** that are adjacent to peripheral outer edge **269** of housing **26**). Because all upper surface portions of housing **26** are covered (either with cover glass or trim), the arrangement of FIG. **13** helps improve the cosmetic appearance of device **10** when viewed from direction **661**.

[0070] The foregoing is merely illustrative of the principles of this invention and various modifications can be made by those skilled in the art without departing from the scope and spirit of the invention.

1-20. (canceled)

21. A portable electronic device, comprising:

a display;

a housing including a shelf that supports the display; and  
a pliant interface positioned between the shelf and the display that couples the display to the housing.

22. The portable electronic device of claim **21**, wherein the pliant interface comprises a gasket.

23. The portable electronic device of claim **21**, wherein the pliant interface comprises an elastomeric material.

24. The portable electronic device of claim **21**, wherein the pliant interface compresses in response to exertion of force upon the display.

25. The portable electronic device of claim **21**, wherein the display comprises a cover coupled to a polarizer layer.

26. The portable electronic device of claim **25**, wherein the cover comprises glass.

27. The portable electronic device of claim **21**, wherein the pliant interface protects the display from the housing.

28. The portable electronic device of claim **21**, wherein the pliant interface is positioned under the display.

29. The portable electronic device of claim **21**, wherein the pliant interface comprises a compressible material.

30. The portable electronic device of claim **21**, wherein the display includes layers not supported by the pliant interface.

**31.** The portable electronic device of claim **21**, wherein the display includes layers not separated from the housing by the pliant interface.

**32.** The portable electronic device of claim **21**, wherein the pliant interface absorbs shock transmitted between the display and the housing.

**33.** The portable electronic device of claim **21**, wherein the display includes an opaque border that blocks view of an internal component.

**34.** The portable electronic device of claim **33**, wherein the internal component comprises the pliant interface.

**35.** The portable electronic device of claim **33**, wherein the opaque border includes an aperture that allows passage of light to a component.

**36.** The portable electronic device of claim **35**, wherein the component comprises at least one of a camera or an ambient light sensor.

**37.** A portable electronic device, comprising:  
a display;  
a frame; and

a flexible coupler positioned between the frame and the display that supports the display.

**38.** The portable electronic device of claim **37**, wherein application of force to the display compresses the flexible coupler.

**39.** A portable electronic device, comprising:  
a display;  
a structure that supports the display; and  
a compliant material that couples the structure to the display.

**40.** The portable electronic device of claim **39**, wherein the compliant material deforms in response to application of force to the display.

\* \* \* \* \*