



(51) International Patent Classification:

G01B 21/04 (2006.01) G05B 19/401 (2006.01)  
G01B 5/10 (2006.01) G01B 5/213 (2006.01)  
G01B 5/20 (2006.01)

(21) International Application Number:

PCT/GB2014/050285

(22) International Filing Date:

3 February 2014 (03.02.2014)

(25) Filing Language:

English

(26) Publication Language:

English

(30) Priority Data:

1302012.8 5 February 2013 (05.02.2013) GB  
1305599.1 27 March 2013 (27.03.2013) GB

(71) Applicant: RENISHAW PLC [GB/GB]; New Mills, Wotton-under-Edge Gloucestershire GL12 8JR (GB).

(72) Inventor: OULD, John; Renishaw plc, New Mills, Gloucestershire, Wotton-under-Edge Gloucestershire GL12 8JR (GB).

(74) Agents: MATTHEWS, Paul et al.; Renishaw plc, Patent Department, New Mills, Wotton-under-Edge Gloucestershire GL12 8JR (GB).

(81) Designated States (unless otherwise indicated, for every kind of national protection available): AE, AG, AL, AM,

AO, AT, AU, AZ, BA, BB, BG, BH, BN, BR, BW, BY, BZ, CA, CH, CL, CN, CO, CR, CU, CZ, DE, DK, DM, DO, DZ, EC, EE, EG, ES, FI, GB, GD, GE, GH, GM, GT, HN, HR, HU, ID, IL, IN, IR, IS, JP, KE, KG, KN, KP, KR, KZ, LA, LC, LK, LR, LS, LT, LU, LY, MA, MD, ME, MG, MK, MN, MW, MX, MY, MZ, NA, NG, NI, NO, NZ, OM, PA, PE, PG, PH, PL, PT, QA, RO, RS, RU, RW, SA, SC, SD, SE, SG, SK, SL, SM, ST, SV, SY, TH, TJ, TM, TN, TR, TT, TZ, UA, UG, US, UZ, VC, VN, ZA, ZM, ZW.

(84) Designated States (unless otherwise indicated, for every kind of regional protection available): ARIPO (BW, GH, GM, KE, LR, LS, MW, MZ, NA, RW, SD, SL, SZ, TZ, UG, ZM, ZW), Eurasian (AM, AZ, BY, KG, KZ, RU, TJ, TM), European (AL, AT, BE, BG, CH, CY, CZ, DE, DK, EE, ES, FI, FR, GB, GR, HR, HU, IE, IS, IT, LT, LU, LV, MC, MK, MT, NL, NO, PL, PT, RO, RS, SE, SI, SK, SM, TR), OAPI (BF, BJ, CF, CG, CI, CM, GA, GN, GQ, GW, KM, ML, MR, NE, SN, TD, TG).

Published:

- with international search report (Art. 21(3))
- before the expiration of the time limit for amending the claims and to be republished in the event of receipt of amendments (Rule 48.2(h))

(54) Title: METHOD AND APPARATUS FOR MEASURING A PART

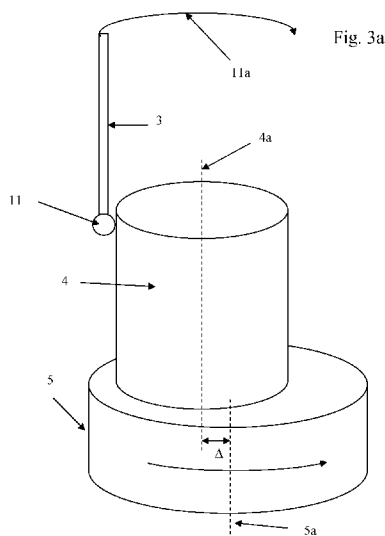

(57) Abstract: This invention concerns a method and apparatus for measuring a part 4 with a contact probe 3 mounted on a coordinate positioning machine 1. The method comprises measuring a plurality of points PC on the part 4 when both the part 3 and contact probe 3 are moving continuously between different positions within the coordinate positioning machine 1. The probe 3 moves, relative to the part 4, along a scan path 20 such that substantially coincident points that are closely located together along a curve or surface being measured are measured at relatively far apart positions in the machine 1 and at relatively far apart positions along the scan path SC.



WO 2014/122437 A1

## METHOD AND APPARATUS FOR MEASURING A PART

### Field of Invention

5 This invention concerns a method and apparatus for measuring a part. This invention has particular application to measuring a part using a coordinate positioning machine, such as a machine tool or coordinate measuring machine.

### Background

10

In machine tools, it is known to measure a part using a contact probe by moving a contact probe along a path such that the probe contacts a surface of the part at a number of points on the surface. A location of the points of contact can be determined from signals from the machine tool and contact probe and an  
15 appropriate shape fitted to these points to obtain a representation of the surface. It is also known to rotate the part with the contact probe fixed in position. Examples of these methods are described in US3866829.

In US3866829, the contact probe is movable parallel to the rotational axis to take  
20 measurements at different heights on the part. However, it is also known to move the contact probe in a direction perpendicular to the rotational axis such that inner and outer circles of a part can be measured, for example as disclosed in EP0744678.

25 Errors in the measurement can result in inaccuracies in the generated representation. In particular, in circumstances when the part is rotated and the contact probe is stationary, a diameter of a cylindrical/circular part cannot be measured directly, but the measured position has to be related to a centre of the part in order to determine a diameter. The rotation can provide information on the  
30 runout of the part about the centre of rotation, but a position of the centre of rotation cannot be determined directly nor the off-centre error of the part with respect to the centre of rotation. It is also not possible to separate the 1<sup>st</sup> order

circularity of the part from the axis centre drift or the off-centre error of the part.

US4852402 discloses a measurement method wherein a contact probe is moved simultaneously with rotation of a gear. The contact probe is moved in a direction  
5 that is orthogonal to a movement direction of a point on a surface of the gear tooth in contact with the contact probe. Deviations from an ideal involute shape of the tooth are recorded.

US6154713 discloses a method of determining a path of a contact probe when  
10 measuring a part that is simultaneously rotated with movement of the contact probe such that measurement of a surface always occurs in a preferred measurement direction, normal to the surface.

US6327788 discloses a method of measuring a set of radial values of a cylindrical  
15 part at a specified height with a nominally straight contact probe by rotating the part relative to the probe when the probe is located at a first, fixed radial position to obtain a first set of radial values and then moving the probe to a second, fixed radial position diametrically opposed to the first position and rotating the part to obtain a second set of radial values. Sets of values may be obtained at each radial  
20 position at a plurality of different heights. In this way, for each point on the part, two measurements of radius are obtained. A mean of the measurements of radius at each point is obtained to compensate for errors in the straightness of the contact probe.

25 In an alternative embodiment, rather than averaging measurements of radius at each point, each set of radial values is fitted to a circle using a least squares algorithm. An average of the fitted circles is obtained. The fitted circle for one of the sets of radial values is then subtracted from the average circle and the result added to the raw radial values of that set.

30

Figures 1a to 1c schematically illustrate this method for a single height wherein a first circle with radius  $R_1$  is fitted to radial values obtained for a first position of

the contact probe and a second circle with radius R2 is fitted to radial values obtained for a second position of the contact probe. An average radius, AV, is obtained for values R1 and R2. A difference between the average radius AV and a radius for one of the sets of data, in the illustration R1, is then added to the radial values to which the circle with radius R1 was fitted to obtain a data set that represents the final shape.

It is disclosed that this second embodiment reduces angular phase errors which may occur if the angular separation of the two positions of the contact probe are not accurately known (i.e. the “same point” measured for the two positions of the contact probe may be, in fact, slightly different points because of errors in the angular measurement at each position. Therefore, simple averaging of the radial position for each point may be false averaging because the measurements are for slightly different points).

Such a method may cancel out errors resulting from the lack of straightness of the contact probe but errors from other sources, such as the part being off-centre from the axis of rotation, deformation of other parts of the measurement system or runout, may still produce significant inaccuracies in the measurement of the part.

### **Summary of Invention**

According to a first aspect of the invention there is provided a method of measuring a part with a contact probe mounted on a coordinate positioning machine, the method comprising measuring a plurality of points on a surface of the part with the part and contact probe each located at a plurality of different positions within the coordinate positioning machine.

The probe may move, relative to the part, along a scan path such that substantially coincident points that are closely located together along a curve or surface being measured are measured at relatively far apart positions in the machine and at relatively far apart positions along the scan path.

The scan path may comprise multiple scans of substantially the same scan path, the coincident points measured on separate scans of the substantially the same scan path. Accordingly, the same points or points close together on the part may  
5 be measured by the probe during different traverses of the scan path. The movement of the part and contact probe in the coordinate measuring machine may be such that different traverses of the same scan path relative to the part comprises travel of the contact probe along different paths relative to the coordinate measuring machine (because the part is also moving relative to the coordinate  
10 measuring machine). In this way, points close together on the part may be measured during different traverses of the scan path with the probe located for each measurement at relatively far apart locations in the coordinate measuring machine.

15 The scan path may comprise a plurality of complete navigations around the part, the coincident points measured on separate complete navigations of the part. Each complete navigation may be around the same circumference of the part. Each complete navigation may be offset in a direction from the other complete navigation(s). The scan path may be a helix or three-dimensional spiral around  
20 the part.

The method may comprise, in between measuring the substantially coincident points that are relatively close together on the curve or surface being measured, measuring other points that are further away from each other on the curve or  
25 surface being measured than the substantially coincident points.

The method may comprise measuring the plurality of points when both the part and the contact probe are moving continuously between the different positions.

30 The method enables a large number of “independent” measurements to be taken within a short time period relative to moving the part and/or contact probe once along a scan path and/or in a series of discrete movements. The cloud of

measured points obtained at different positions of the part and contact probe in the machine may be analysed together on the assumption that errors for the points are uncorrelated and normally distributed. More specifically, measuring points that are closely located to each other on the part in substantially different locations in the machine volume may reduce measurement uncertainty because each measurement may be considered “independent” with few, if any, systematic errors common to the measurements. With independent measurements, measurement uncertainty falls with  $1/\sqrt{N}$ , where N is the number of measurements of each point

10 The contact probe may be a multi-axis contact probe, in which measurements can be carried out through deflections of a stylus of the probe in any one of a plurality of measurement directions, the probe generating signals indicative of both magnitude and direction of the deflection, the method comprising moving the contact probe and the part such that the contact probe carries out measurements  
15 through deflection of the stylus in at least two of the measurement directions. In this way, systematic errors due to a single measurement direction of the probe may be avoided.

The method may comprise fitting an analytical curve or surface to the plurality of  
20 points to obtain a representation of the surface.

Errors in each measurement will depend on the position of the probe and part within the coordinate positioning machine. Fitting an analytical curve or surface to the plurality of points finds a curve or surface that best fits the measured points  
25 “averaging” out the errors that occur (or in other words, fitting creates an approximating function that attempts to capture a shape of the part whilst smoothing out variations due to errors). The type of “averaging” will depend on the method used to evaluate the analytical curve or surface that best fits the plurality of points. For example, a least squares algorithm will minimise the sum  
30 of the squares of a distance between the points and the analytical curve or surface. Consequently, the resultant representation of the surface will take account of errors from various sources, such as deformations of the contact probe and/or

coordinate positioning machine and runout.

The method may comprise rotating the part within the coordinate positioning machine between the different positions. The continuous motion may comprise  
5 movement of the probe and the part in non-orthogonal directions. For example, both the part and the contact probe may be moved in opposed directions (clockwise/anticlockwise) along closed paths for the duration in which measurements are obtained. The part and the contact probe may be rotated in  
10 opposite directions. Additionally or alternatively, the method may comprise a translation (as opposed to or in addition to a rotation) of the part between the different positions.

The method may comprise transforming a location of each point in a coordinate system of the coordinate positioning machine (hereinafter referred to as “the  
15 measurement coordinate system”) into a location in a part coordinate system in which relative locations of the points on the part are defined. A position of the part in the coordinate positioning machine may be determined at the time each point is measured, the location of the point within the measurement coordinate system being transformed into the location in the part coordinate system using the  
20 determined position of the part. In the case where the part has been rotated, the transformation comprises a rotational transformation of the location based on an angle the part has been rotated through from a reference position.

The curve or surface may be fitted to the points once the points have been  
25 transformed into the part coordinate system. The fitting of an analytical curve or surface may comprise a least squares fit, a freeform surface modelling technique, such as a non-uniform rational basis b-spline (NURBS) algorithm, or other suitable fitting algorithm.

30 The method may comprise determining a path within the coordinate measuring machine for the contact probe to travel based upon an intended displacement of the part during measurement. The path of the contact probe and/or displacement

of the part may be selected based upon set criteria. For example, the path of the contact probe and/or displacement of the part may be selected such that the entire surface of the part can be measured within a limited measuring range of the contact probe and/or to ensure measurements are taken across a significant extent  
5 of a volume available for such measurements and/or to ensure that accelerations/decelerations of the contact probe and/or mount that moves the part are within defined limits.

The part may be moved to the different positions in discrete steps or in a  
10 continuous motion.

The method may comprise moving the contact probe and the part such that the contact probe circumnavigates the part multiple times.

15 The method may comprise selecting a path of the contact probe and/or a displacement of the part such that the same point or points that are closely located to each other on the part are measured at two or more locations that are relatively far away in the coordinate positioning machine.

20 According to a second aspect of the invention there is provided a coordinate positioning machine comprising a first mount for mounting a contact probe for movement within the coordinate positioning machine, a second mount for mounting a part for movement within the coordinate positioning machine and a controller for controlling movement of the first and second mounts, wherein the  
25 controller is arranged to control movement of the first and second mounts to measure with the contact probe a plurality of points on a surface of the part with the part and contact probe each located at a plurality of different positions within the coordinate positioning machine.

30 The controller may be arranged to control movement of the first and second mounts to move the probe relative to the part along a scan path such that substantially coincident points that are closely located together along a curve or



surface being measured are measured at relatively far apart positions in the machine and at relatively far apart positions along the scan path.. Accordingly, points close together on the part may be measured by the probe during different traverses of the scan path. The movement of the part and contact probe in the coordinate measuring machine may be such that different traverses of the same scan path relative to the part comprises travel of the contact probe along different paths relative to the coordinate measuring machine (because the part is also moving relative to the coordinate measuring machine). In this way, points close together on the part may be measured during different traverses of the scan path with the probe located for each measurement at relatively far apart locations in the coordinate measuring machine.

The controller may be arranged to control movement of the first and second mounts to measure with the contact probe the plurality of points when both the part and contact probe are moving continuously between the different positions.

The contact probe may be a multi-axis contact probe, in which measurements can be carried out through deflections of a stylus of the probe in any one of a plurality of measurement directions, the probe generating signals indicative of both magnitude and direction of the deflection, the controller arranged to control movement of the first and second mounts such that, during the continuous motion, the contact probe carries out measurements through deflection of the stylus in at least two of the measurement directions.

The coordinate positioning machine may comprise an evaluation unit for analysing signals from the coordinate positioning machine and contact probe, the evaluation unit arranged to fit an analytical curve or surface to the plurality of points to obtain a representation of the surface.

The coordinate positioning machine may be a machine tool or a coordinate measuring machine (CMM).

According to a third aspect of the invention there is provided a data carrier having instructions thereon, wherein, when the instructions are executed by a processor, the processor is caused to control movement of first and second mounts of a coordinate positioning machine, the first mount for mounting a contact probe  
5 within the coordinate positioning machine and a second mount for mounting a part within the coordinate positioning machine, wherein the processor moves the first and second mounts to measure with the contact probe a plurality of points on a surface of the part when both the part and contact probe are moving continuously between different positions within the coordinate positioning machine.

10

The processor moves the first and second mounts to move the probe, relative to the part, along a scan path such that substantially coincident points that are closely located together along a curve or surface being measured are measured at relatively far apart positions in the machine and at relatively far apart positions  
15 along the scan path..

The first mount may be for mounting a multi-axis contact probe, in which measurements can be carried out through deflections of a stylus of the probe in any one of a plurality of measurement directions, the probe generating signals  
20 indicative of both magnitude and direction of the deflection, and the processor may control movement of the first and second mounts such that the contact probe carries out measurements through deflection of the stylus in at least two of the measurement directions.

25 According to a fourth aspect of the invention there is provided a data carrier having instructions thereon, wherein, when the instructions are executed by a processor, the processor is caused to receive measurement data of a plurality of points measured on a surface of a part using a contact probe mounted on a coordinate positioning machine, wherein the plurality of points are obtained with  
30 the part and contact probe each located at a plurality of different positions within the coordinate positioning machine, and to fit an analytical curve or surface to the plurality of points to obtain a representation of the surface.

According to a fifth aspect of the invention there is provided a method of measuring a part with a contact probe mounted on a coordinate positioning machine, the method comprising measuring a plurality of points on a surface of the part with the part and contact probe each located at a plurality of different positions within the coordinate positioning machine and transforming each point into a common part coordinate system in which relative locations of the plurality of points on the part are defined based on a determined position of the part in the coordinate positioning machine when the point was measured.

10

The method may comprise recording part position data on a position of the part relative to a part reference point in the coordinate positioning machine and the transformation of each point into a common part coordinate system is based upon the part position data. The part may be mounted on a rotary table and the position data may be the angular orientation of the rotary table.

15

According to a sixth aspect of the invention there is provided a coordinate positioning machine comprising a first mount for mounting a contact probe for movement within the coordinate positioning machine, a second mount for mounting a part for movement within the coordinate positioning machine, a controller for controlling movement of the first and second mounts and an evaluation unit for analysing signals from the coordinate positioning machine and contact probe, wherein the controller is arranged to control movement of the first and second mounts to measure with the contact probe a plurality of points on a surface of the part with the part and contact probe each located at a plurality of different positions within the coordinate positioning machine and the evaluation unit is arranged to transform each point into a common part coordinate system in which relative locations of the plurality of points on the part are defined based on a determined position of the part in the coordinate positioning machine when the point was measured.

20

25

30

According to a seventh aspect of the invention there is provided a data carrier

having instructions thereon, wherein, when the instructions are executed by a processor, the processor is caused to receive measurement data of a plurality of points measured on a surface of a part using a contact probe mounted on a coordinate positioning machine, wherein the plurality of points are obtained with  
5 the part and contact probe each located at a plurality of different positions within the coordinate positioning machine, and to transform each point into a common part coordinate system in which relative locations of the plurality of points on the part are defined based on a determined position of the part in the coordinate positioning machine when the point was measured

10

The instructions, when executed by the processor, may cause the processor to receive part position data together with the measurement data, the determined position of the part being determined from the part position data. Each point of the plurality of points may be associated with a part position contained in the part  
15 position data.

The data carrier of the above aspects of the invention may be a suitable medium for providing a machine with instructions such as non-transient data carrier, for example a floppy disk, a CD ROM, a DVD ROM / RAM (including - R/-RW and  
20 +R/ + RW), an HD DVD, a Blu Ray(TM) disc, a memory (such as a Memory Stick(TM), an SD card, a compact flash card, or the like), a disc drive (such as a hard disk drive), a tape, any magneto/optical storage, or a transient data carrier, such as a signal on a wire or fiber optic or a wireless signal, for example a signals sent over a wired or wireless network (such as an Internet download, an FTP  
25 transfer, or the like).

### **Description of the Drawings**

**FIGURES 1a, 1b and 1c** show a prior art method of measuring a  
30 cylindrical part;

**FIGURE 2** is a schematic view of apparatus according to one embodiment

of the invention;

**FIGURE 3a** is a perspective view of a cylindrical part being measured in accordance with an embodiment of the invention;

5

**FIGURE 3b** shows a scan path relative to the cylindrical part traversed by the contact probe;

**FIGURE 4** is a flow chart illustrating the recording and processing of data measured using the method shown in Figure 3;

10

**FIGURE 5** shows a method of fitting a curve to a plurality of points measured on a part in accordance with an embodiment of the invention;

15

**FIGURE 6a** is a data plot of probe deflection obtained when carrying out a measurement using a method according to an embodiment of the invention;

**FIGURE 6b** is a data plot of residuals within the probe deflection data shown in Figure 6a following compensation for offsets in the rotation axis and part centre from expected locations;

20

**FIGURE 7a** is a schematic view of a further part being measured in accordance with an embodiment of the invention;

25

**FIGURE 7b** shows a scan path relative to the further part traversed by the contact probe; and

**FIGURE 8** shows a schematic view of another part and a scan path around the part.

30

### Description of Embodiments

Referring to Figure 2, a coordinate positioning machine 1 comprises a machine tool 2 and a contact probe 3, in this embodiment a multi-axis contact probe, mounted on the machine tool 2 for measuring a part 4. The machine tool  
5 comprises a rotary table 5 on which the part 4 can be mounted. The rotary table 5 comprises a rotary axis 5a. The contact probe 3 is mounted to a quill 6 which is mounted on arms 7 and 8 such that the contact probe 3 can be moved in three linear directions, x, y and z relative to a base 9. The extent of movement of the  
10 probe 3 will be constrained by the construction of the machine tool 2 and may not extend across the entire volume of a part mounted in the machine tool 2. In this embodiment, the volume within which the probe 3 can move is indicated by dotted and dashed box 13.

15 Motors 15a, 15b, 15c, 15d move the rotary table 5, quill 6 and arms 7 and 8 under the control of controller 10, such as processor programmed with suitable software. Encoders 14a, 14b, 14c, 14d in the quill 6, arms 7,8 and rotary table 5 generate signals indicative of positions of the table 5, quill 6 and arms 7,8 from which a location of the contact probe 3 and part 4 in a measurement coordinate system 16  
20 of the machine tool 2 can be determined.

The contact probe 3 has transducers that generate a signal when the probe 3 is deflected, such as through contact with the part 4. From the signals generated by the contact probe 5 and the encoders 14a, 14b, 14c, 14d, points of contact of the  
25 probe tip 11 with the part 4 can be determined within the measurement system. A plurality of points on the part 4 measured in this way are recorded and processed by evaluation unit 12, which may be a processor programmed with suitable software and may be the same or a different processor to that used for the controller 10. The contact probe 3 may communicate with the evaluation unit 12  
30 wirelessly.

A method of measuring a part with the coordinate positioning machine 1 in

accordance with an embodiment of the invention will now be described with reference to Figures 3a, 3b and 4. In this embodiment, the part 4 is nominally cylindrical and mounted on the rotary table 5 such that its central axis 4a approximately aligns with the rotary axis 5a of the rotary table 5. Measurements of points on the surface of the part 4 are recorded by rotating the table 5 in one rotary direction (in the drawings, anticlockwise) and simultaneously moving the contact probe 3 along a path 11a relative to the machine tool 2, in this embodiment a circular path, in the other direction (in the drawings, clockwise). The combined motion of the part 4 and probe 3 causes the contact probe 3 to traverse a scan path 20 (indicated by the dotted lines in Figure 3b) relative to the part 4 that allows to contact probe 11 to measure points spaced around a circumference of the part 6. The rotation of the table 5 and movement of the probe 3 is carried out as a continuous movement, although discrete steps are possible but less desirable. Measurements may be recorded continuously, for example, if the contact probe 3 is a scanning probe, or as a number of discrete points, for example if the contact probe 3 is a touch trigger probe.

The signals from the contact probe 3 and the encoders 14a, 14b, 14c of the machine tool 2 and encoder 14d of the rotary table 5 are sent to the evaluation unit 12. The evaluation unit 12 determines a location P of points measured using the contact probe 3 in the measurement coordinate system 16 of the machine tool 2. In Figure 4, individual measurements of points on the part 4 for particular locations of the probe 3 and part 4 are shown in column A and column B shows these points plotted together in the coordinate system 16 of the machine tool 12. The evaluation unit then transforms, in this embodiment, by a suitable rotational transformation  $T$ , the locations P of these points into locations PC in a part coordinate system, as shown in column C, wherein the relative positions of the points on the part 4 are defined. The rotation  $T$  required to transform a location P in the measurement coordinate system 16 into a location PC in the part coordinate system may be determined from a position of the part 4 in the machine tool 2 when the point was measured relative to a reference position, such as a position of the part 4 when the first point is measured. The transformation  $T$  may be

determined from the angle (indicated by the arc between the dotted (initial position) and solid (current position) in the plots of column A) the rotary table 4 has rotated through between the two measurements, which can be determined from the signals of the encoder 14d in the rotary table 5.

5

In this embodiment, the part 4 is rotated through 180° and the path travelled by the probe 3 in the machine tool is an arc of 180° in the opposite direction. In this way, the time taken to navigate the entire circumference of the part 4 is less than would be the case if only the rotary table 4 or probe 3 was moved at the same speed.

10

An analytical curve 15 is then fitted to the points in the part coordinate system, such as using a least square fit algorithm, to obtain a representation of the part 4. This is illustrated by the last plot in column C of Figure 4.

15

In another embodiment, a path of the probe 3 and/or a rotation of the rotary table 5 are such that the contact probe 2 traverses the same scan path 20 relative to the part 4 multiple times such that the same points or points close together on the surface of the part 4 can be measured by the probe during different traverses of the scan path 20. Accordingly, substantially coincident points that are closely located to each other on the part 4 may be measured in two or more locations P that are relatively far away in the machine tool 2 and at relatively far apart positions along the scan path 20. The locations P of these points are transformed into locations PC in the part coordinate system and an illustration of a cloud of points that may result from such a method is shown in Figure 5. A curve 115 is fitted to all points PC of the cloud to obtain a representation of the part. Such a method may reduce measurement uncertainty as the measurement of the same points or points that are closely located together on the part 4 at relatively far apart locations in the machine tool 2 may be considered as substantially independent such that reduction in measurement uncertainty with revolutions of the probe 3 around the part 4 will tend towards  $1/\sqrt{N}$ , where N is the number of revolutions.

20

25

30

As illustrated in Figure 3a, the centre of the part 4 may be offset by a distance,  $\Delta$ ,



from the rotational axis 5a of the rotary table 5. (In Figure 3a the offset is exaggerated for clarity). During processing of the measurements, initially, it may be assumed that the part 4 is centred about a location of a rotational axis 5a of rotary table 5 and that the location of the rotational axis 5a is a location previously determined, for example using a calibration. However, the location of the rotational axis 5a may differ from the previously determined location, for example due to the weight of the part 4, drift over time, temperature changes, etc. Using locations in the analysis that are offset from the actual locations of the rotational axis and centre 4a of the part 4 can result in sinusoidal artefacts in the probe deflection data, as shown in Figure 6a. The half-cycle sinusoid is caused by the probe's movement in the machine volume not being centred about the rotational axis 5a. This sinusoid gives information about the centre 5a of rotation of the part 4 and the diameter of the part 4. The higher frequency sinusoid is caused by the centre 4a of the part 4 being misaligned with the rotational axis 5a. This higher frequency sinusoid gives you information about the offset of the centre of the part 4 from the rotational axis 5a and the roundness of the part 4. The large deflection that is seen at the start and end of Figure 6a is the probe contacting and leaving the surface of the part.

By adding an appropriate offset in the X and Y directions to the assumed centre of the part 4 and assumed location of the rotational axis when analysing the results these sinusoidal artefacts in the measurement results can be reduced or even eliminated, as shown in Figure 6b (leaving simply a deviation of the point from a baseline, such as a probe position relative to the part). The appropriate offset may be determined from sinusoidal functions fitted to the data. A magnitude of the offset may be determined from the amplitude of the sinusoid and a direction from the phase. Offsets may have to be calculated along the Z-axis as the rotational axis 5a may not be parallel to the Z-axis of the probe 3.

The appropriate offset may be determined in an iterative process, wherein, in each iteration, the points measured in the machine's coordinate system are transformed into the part coordinate system based upon a position of the part 4 determined

using the current assumed position for the rotational axis. In the part coordinate system, sinusoidal functions are fitted to the points PC and offsets determined for each of the rotational axis and centre of the part. The result is analysed to determine if any sinusoidal artefact remains. If so, the new positions (old  
5 positions plus offset) for the rotational axis and centre of the part are used in the next iteration. This process continues until the sinusoidal artefact is eliminated or reduced below an acceptable level. The measured offset of the centre of the part 4 from the rotational axis 5a and the location of the rotational axis is then taken to be that determined in the final iteration.

10

Figures 7a and 7b illustrate a further embodiment of the invention, wherein a non-cylindrical part 204 is measured. In this example, the non-cylindrical part 204 has a length that is greater than the dimensions of the volume 13 within which the probe 3 can move. The part 204 is mounted on the rotary table 5. Rotation of the  
15 part 204 and the path 216 of the probe 3 in the machine tool 2 are selected such that an entire circumference of a surface on the part 204 can be measured even though the points on the part 204 that are measured may at certain orientations of the part 204 fall outside the volume 13 in which the probe 3 can measure a part, as illustrated in Figure 5. The scan path 220 of the contact probe 3 relative to the  
20 part 204 is shown in Figure 7b.

As in the previous embodiment, the locations P of the points measured in the coordinate system 16 of the machine tool 2 are transformed  $T$  into locations PC in the part coordinate system. A curve 215 is fitted to the points in the part  
25 coordinate system to obtain a representation of the part. Not shown in Figure 7a but, in practice, the contact probe 3 will traverse the scan path 220 multiple times, whereas the path 216 of the contact probe within the machine tool 2 may only be traversed once or at least fewer times than the scan path 220. This allows points, such as PC1 and PC10 that are relatively close together on the part 204 to be  
30 measured at relatively far apart positions in the coordinate positioning machine 2.

In another embodiment, rather than fitting a 2-dimensional curve to a set of points

that are believed to be within the same plane, points may be measured in 3-dimensions and a 3-dimensional surface may be fitted to measured points when transformed into the part coordinate system.

5 Figure 8 is an example of the fitting of a surface to the plurality of measured points. In this embodiment, the part 304 is a cylindrical shaped part. As before, the part 304 is scanned by moving the part 304 simultaneously with movement of the probe. In this embodiment, the movement is such that the probe traverses a helical scan path 320 relative to the part 304. For example the part 304 may be  
10 rotated simultaneously with rotational and translational (such as in the z-direction) movement of the probe. In such an arrangement, each point PC1, PC2 is only scanned once. However, the turns of the helical path 320 are sufficiently tight relative to the size of the surface being measured (typically, the turns being tighter than those shown in the drawings, such a feature not being shown for reasons of  
15 clarity) that corresponding points PC1, PC2 on adjacent turns are close enough to each other on the surface to be considered substantially coincident (each turn thus being a scan along substantially the same path as a previous scan). In particular, any variation in the surface that may occur between adjacent turns and corresponding points PC1 and PC2 is relatively small compared to errors in  
20 measurement that may originate from the probe or coordinate positioning machine. In one sense this is similar to the 2-dimensional embodiments described above, wherein measuring the exact same point on each traversal of the scan path may not be possible but it is sufficient that the measured points are sufficiently close together to capture any deviations in the surface that are within the  
25 measurement errors of the machine.

The movement of the part 304 and probe are selected such that corresponding points PC1, PC2 on adjacent turns of the helical are measured at relatively far apart positions in the machine. In this way, the measurements can be considered  
30 “independent”. Furthermore, in moving between points PC1 and PC1, the probe travels a distance along the scan path 320 that is much greater than the distance between the points PC1, PC2 on the surface being measured; in other words, the

scan path is chosen such that the probe returns to a point PC2 substantially coincident with a previously scanned point PC1 after having scanned points that are not coincident with point PC1. In this way, measurement data can be collected on other measurement points as the part and probe are shifted to a new location in  
5 which corresponding point PC2 is to be measured.

It will be understood that the scanning method described with reference to Figure 8 could be applied to other shaped parts, and is particularly appropriate for shapes comprising a curved surface, such as other cylindrical shapes, cones, annuli, bores  
10 or the like.

It will be understood that modifications and alterations may be made to the above described embodiments without departing from the scope of the invention as defined herein.  
15

**CLAIMS**

1. A method of measuring a part with a contact probe mounted on a coordinate positioning machine, the method comprising measuring a plurality of points on the part when both the part and contact probe are moving continuously between different positions within the coordinate positioning machine, the probe moving, relative to the part, along a scan path such that substantially coincident points that are closely located together along a curve or surface being measured are measured at relatively far apart positions in the machine and at relatively far apart positions along the scan path.
2. A method according to claim 1, wherein, the scan path comprises multiple scans of substantially the same scan path, the coincident points measured on separate scans of the substantially the same scan path.
3. A method according to claim 1 or claim 2, wherein the scan path comprises a plurality of complete navigations around the part, the coincident points measured on separate complete navigations of the part.
4. A method according to claim 3, wherein each complete navigation is around the same circumference of the part.
5. A method according to claim 3, wherein each complete navigation is offset in a direction from the other complete navigation(s).
6. A method according to claim 5, wherein the scan path is a helix or three-dimensional spiral around the part.
7. A method according to any one of the preceding claims, the method comprising, in between measuring the substantially coincident points that are relatively close together on the curve or surface being measured, measuring other points that are further away from each other on the curve or surface being measured than the substantially coincident points.

8. A method according to any one of the preceding claims, wherein the continuous motion comprises movement of the probe and the part in non-orthogonal directions.

5

9. A method according to any one of the preceding claims, wherein the contact probe is a multi-axis contact probe, in which measurements can be carried out through deflection of a stylus of the probe in any one of a plurality of measurement directions, the probe generating signals indicative of both magnitude and direction of the deflection, the method comprising moving the contact probe and the part such that, during the continuous motion, the contact probe carries out measurements through deflection of the stylus in at least two of the measurement directions.

10

15

10. A method of measuring a part with a multi-axis contact probe mounted on a coordinate positioning machine, the multi-axis contact probe capable of carrying out measurements through deflection of a stylus of the probe in any one of a plurality of measurement directions, the probe generating signals indicative of both magnitude and direction of the deflection, the method comprising measuring a plurality of points on a surface of the part when both the part and contact probe are moving continuously between different positions within the coordinate positioning machine, the continuous motion being such that the contact probe carries out the measurements through deflection of the stylus in at least two of the measurement directions.

20

25

11. A method according to any one of claims 1 to 10, comprising fitting an analytical curve or surface to the plurality of points to obtain a representation of the part.

30

12. A method of measuring a part with a contact probe mounted on a coordinate positioning machine, the method comprising measuring a plurality of points on a surface of the part with the part and contact probe each located at a plurality of different positions within the coordinate positioning machine and

fitting an analytical curve or surface to the plurality of points to obtain a representation of the surface.

13. A method according to any one of claims 1 to 12, comprising transforming  
5 a location of each point in a measurement coordinate system into a location in a part coordinate system in which relative positions of the points on the part are defined.

14. A method according to claim 13, wherein a position of the part in the  
10 coordinate positioning machine is determined at the time each point is measured, the location of the point within the coordinate positioning machine transformed into the location in the part coordinate system using the determined position of the part.

15. A method according to claim 13 or claim 14 when dependent through to  
claim 11 or claim 12, wherein the curve or surface is fitted to the points once the points have been transformed into the part coordinate system.

16. A method according to any one of the preceding claims, comprising  
20 rotating the part within the coordinate positioning machine between the different positions.

17. A method according to any one of the preceding claims, comprising a  
25 translation of the part within the coordinate positioning machine between the different positions

18. A method according to any one of the preceding claims, comprising  
determining a path for the contact probe to travel based upon an intended  
30 displacement of the part during measurement.

19. A method according to claim 18, wherein the path of the contact probe  
and/or displacement of the part is selected based upon set criteria.

20. A method according to claim 19, wherein the set criteria comprise a

limited measurement range of the contact probe.

21. A method according to claim 19, comprising selecting a path of the contact probe and/or a displacement of the part such that points that are closely located to  
5 each other on the part are measured at two or more locations that are relatively far away in the coordinate positioning machine.

22. A coordinate positioning machine comprising a first mount for mounting a contact probe for movement within the coordinate positioning machine, a second  
10 mount for mounting a part for movement within the coordinate positioning machine and a controller for controlling movement of the first and second mounts, wherein the controller is arranged to control movement of the first and second mounts to measure with the contact probe a plurality of points on a surface of the part when both the part and contact probe are moving continuously between  
15 different positions within the coordinate positioning machine, the probe moving, relative to the part, along a scan path such that substantially coincident points that are closely located together along a curve or surface being measured are measured at relatively far apart positions in the machine and at relatively far apart positions along the scan path.

20  
23. A coordinate positioning machine comprising a first mount for mounting a multi-axis contact probe for movement within the coordinate positioning machine, the multi-axis contact probe capable of carrying out measurements through deflection of a stylus of the probe in any one of a plurality of measurement  
25 directions, the probe generating signals indicative of both magnitude and direction of the deflection, a second mount for mounting a part for movement within the coordinate positioning machine and a controller for controlling movement of the first and second mounts, wherein the controller is arranged to control movement of the first and second mounts to measure with the contact probe a plurality of  
30 points on a surface of the part when both the part and contact probe are moving continuously between different positions within the coordinate positioning machine such that, during the continuous motion, the contact probe carries out



measurements through deflection of the stylus in at least two of the measurement directions.

24. A coordinate positioning machine comprising a first mount for mounting a  
5 contact probe for movement within the coordinate positioning machine, a second  
mount for mounting a part for movement within the coordinate positioning  
machine, a controller for controlling movement of the first and second mounts and  
an evaluation unit for analysing signals from the coordinate positioning machine  
and contact probe, wherein the controller is arranged to control movement of the  
10 first and second mounts to measure with the contact probe a plurality of points on  
a surface of the part with the part and contact probe each located at a plurality of  
different positions within the coordinate positioning machine and the evaluation  
unit is arranged to fit an analytical curve or surface to the plurality of points to  
obtain a representation of the surface.

15 25. A data carrier having instructions thereon, wherein, when the instructions  
are executed by a processor, the processor is caused to control movement of first  
and second mounts of a coordinate positioning machine, the first mount for  
mounting a contact probe within the coordinate positioning machine and a second  
20 mount for mounting a part within the coordinate positioning machine, wherein the  
processor moves the first and second mounts to measure with the contact probe a  
plurality of points on a surface of the part when both the part and contact probe  
are moving continuously between different positions within the coordinate  
positioning machine, the probe moving, relative to the part, along a scan path such  
25 that substantially coincident points that are closely located together along a curve  
or surface being measured are measured at relatively far apart positions in the  
machine and at relatively far apart positions along the scan path.

30 26. A data carrier having instructions thereon, wherein, when the instructions  
are executed by a processor, the processor is caused to control movement of first  
and second mounts of a coordinate positioning machine, the first mount for  
mounting a multi-axis contact probe within the coordinate positioning machine,  
the multi-axis contact probe capable of carrying out measurements through

deflections of a stylus of the probe in any one of a plurality of measurement directions, the probe generating signals indicative of both magnitude and direction of the deflection, and a second mount for mounting a part within the coordinate positioning machine, wherein the processor moves the first and second mounts to  
5 measure with the contact probe a plurality of points on a surface of the part when both the part and contact probe are moving continuously between different positions within the coordinate positioning machine, and such that the contact probe carries out measurements through deflection of the stylus in at least two of the measurement directions.

10

27. A data carrier having instructions thereon, wherein, when the instructions are executed by a processor, the processor is caused to receive measurement data of a plurality of points measured on a surface of a part using a contact probe mounted on a coordinate positioning machine, wherein the plurality of points are  
15 obtained with the part and contact probe each located at a plurality of different positions within the coordinate positioning machine, and to fit an analytical curve or surface to the plurality of points to obtain a representation of the surface.

20

28. A method of measuring a part with a contact probe mounted on a coordinate positioning machine, the method comprising measuring a plurality of points on a surface of the part with the part and contact probe each located at a plurality of different positions within the coordinate positioning machine and transforming each point into a common part coordinate system in which relative locations of the plurality of points on the part are defined based on a determined  
25 position of the part in the coordinate positioning machine when the point was measured.

30

29. A method according to claim 28, comprising recording part position data on a position of the part relative to a part reference point in the coordinate positioning machine and the transformation of each point into a common part coordinate system is based upon the part position data.

30. A coordinate positioning machine comprising a first mount for mounting a

contact probe for movement within the coordinate positioning machine, a second mount for mounting a part for movement within the coordinate positioning machine, a controller for controlling movement of the first and second mounts and an evaluation unit for analysing signals from the coordinate positioning machine and contact probe, wherein the controller is arranged to control movement of the first and second mounts such that a plurality of points on a surface of the part can be measured with the part and contact probe each located at a plurality of different positions within the coordinate positioning machine and the evaluation unit is arranged to transform each point into a common part coordinate system in which relative locations of the plurality of points on the part are defined based on a determined position of the part in the coordinate positioning machine when the point was measured.

31. A data carrier having instructions thereon, wherein, when the instructions are executed by a processor, the processor is caused to receive measurement data of a plurality of points measured on a surface of a part using a contact probe mounted on a coordinate positioning machine, wherein the plurality of points are obtained with the part and contact probe each located at a plurality of different positions within the coordinate positioning machine, and to transform each point into a common part coordinate system in which relative locations of the plurality of points on the part are defined based on a determined position of the part in the coordinate positioning machine when the point was measured.

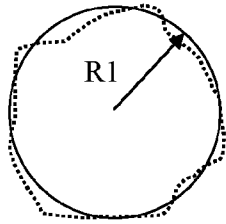

Fig. 1a

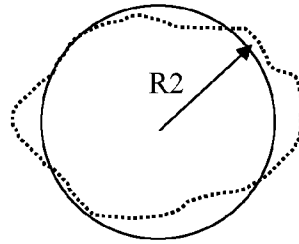

Fig. 1b

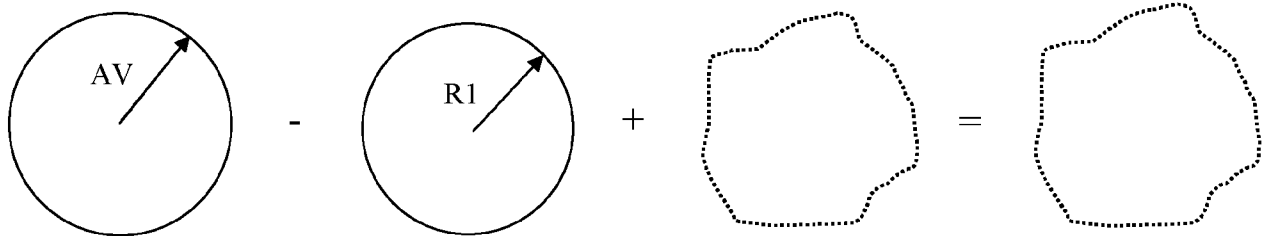

Fig. 1c

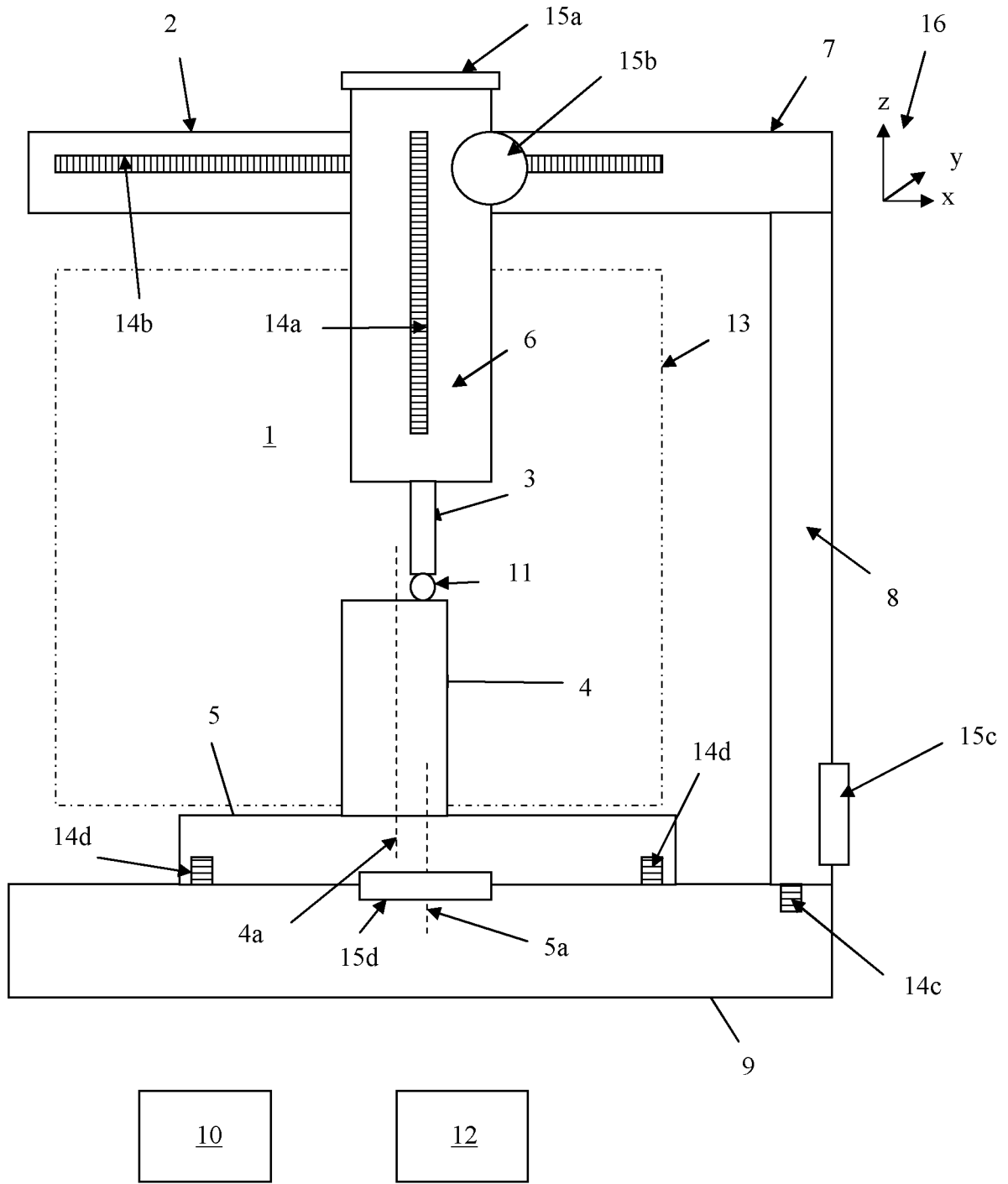

Fig. 2

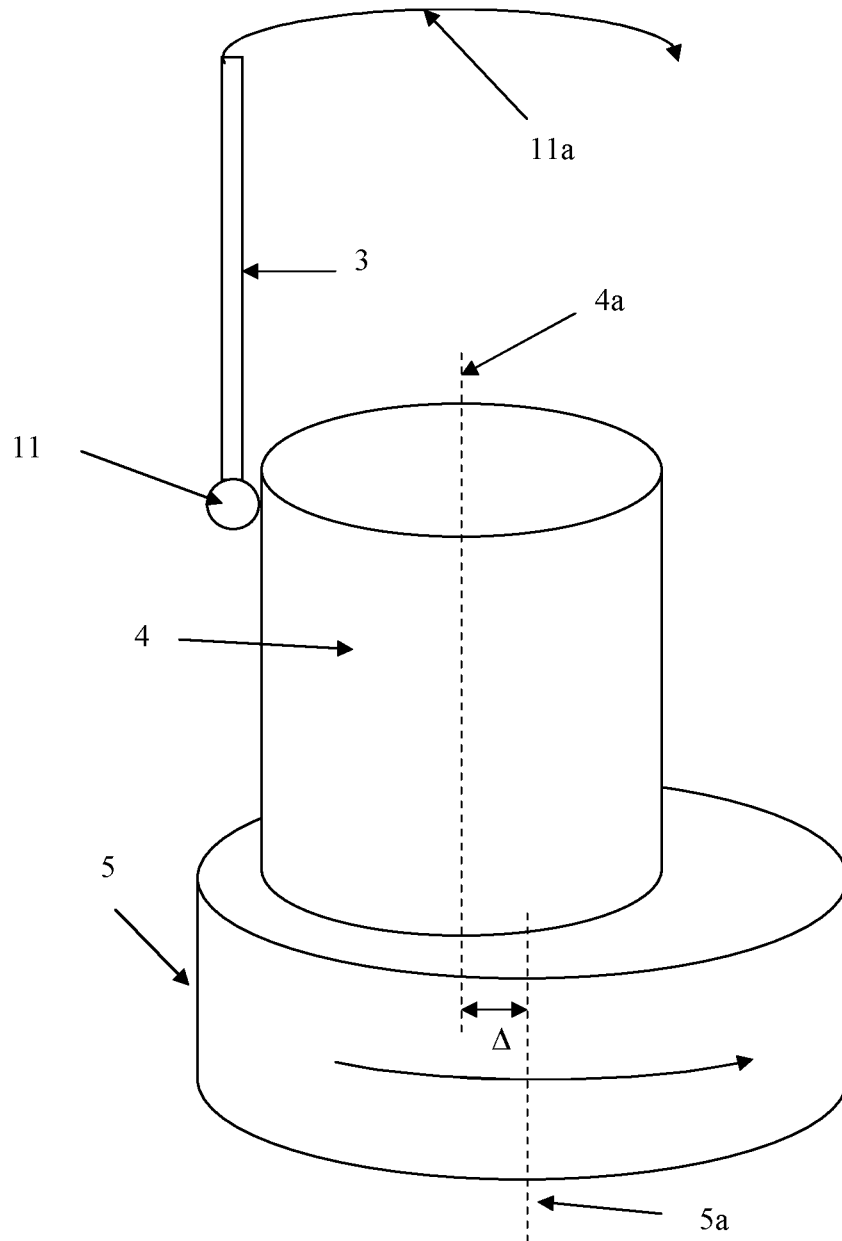

Fig. 3a

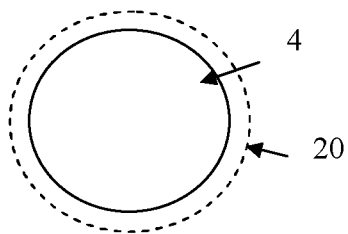

Fig. 3b

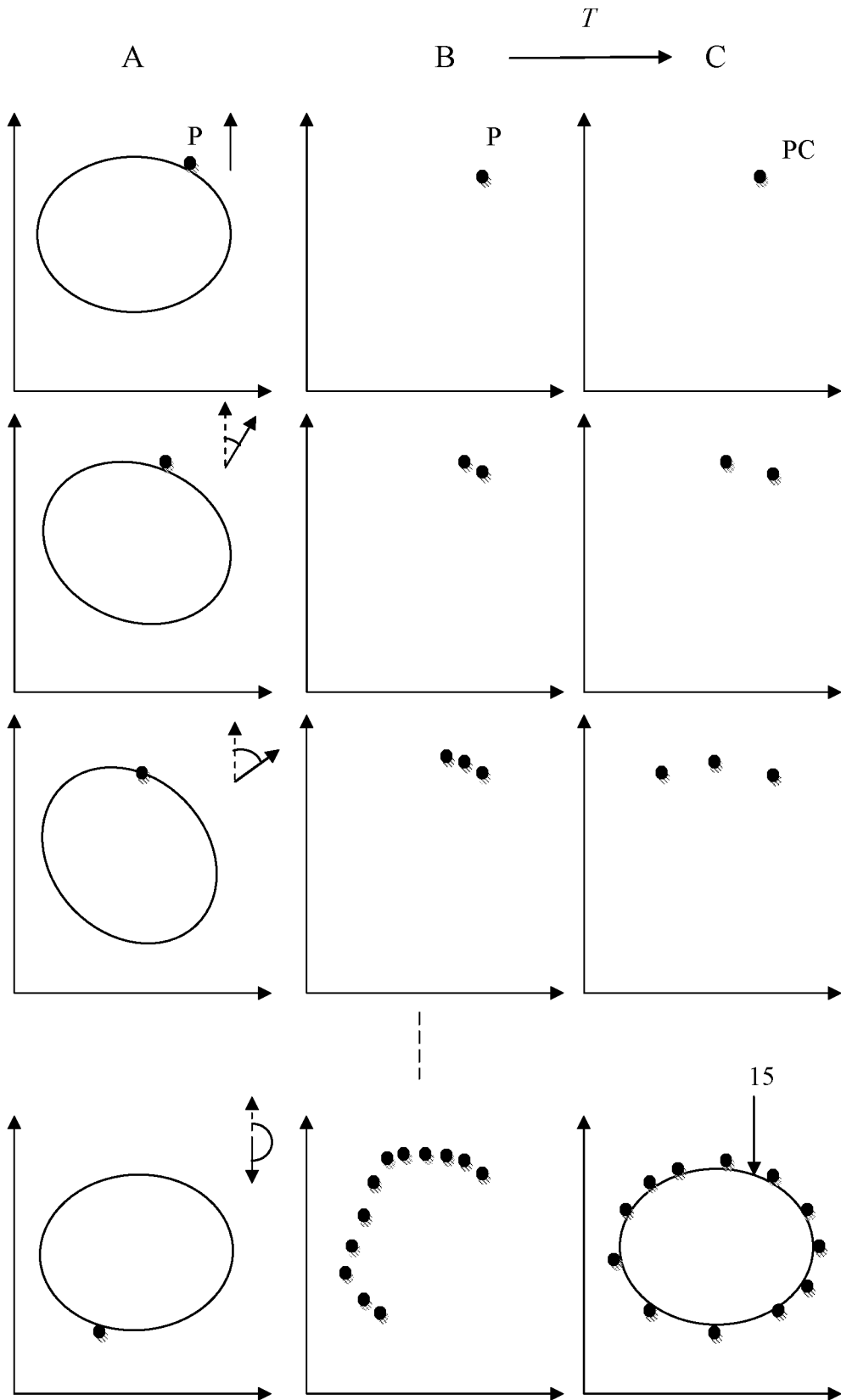

Fig. 4

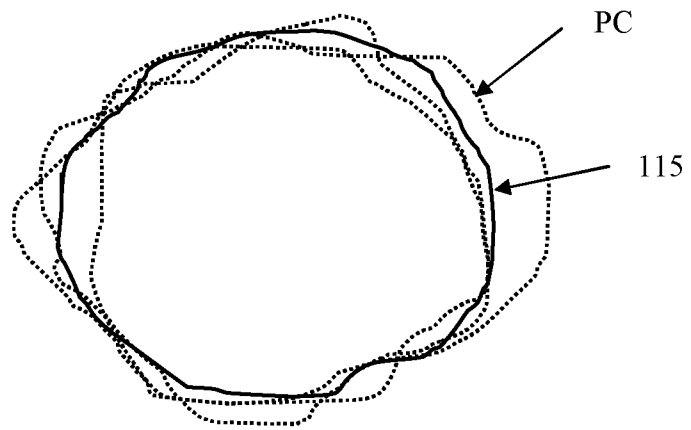

Fig. 5



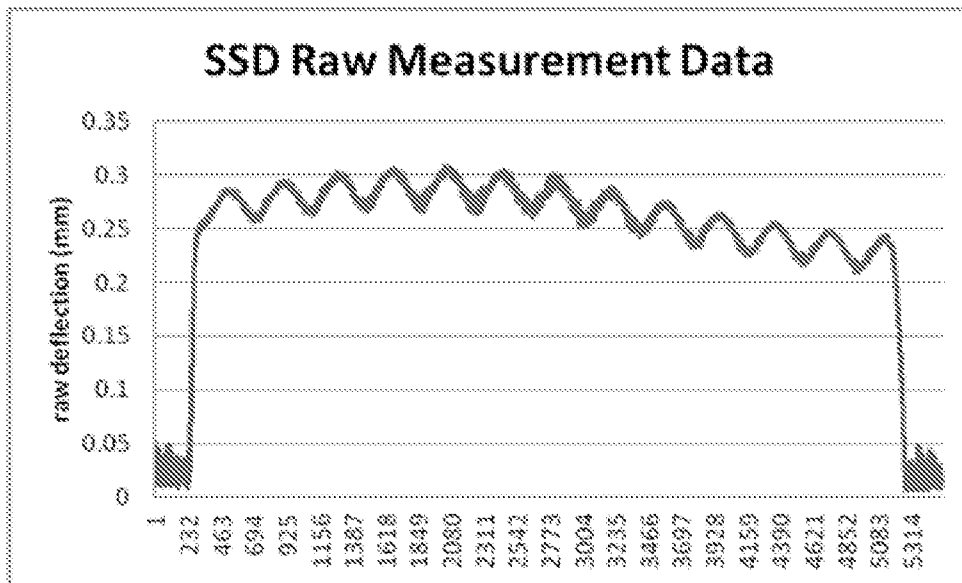

Fig. 6a

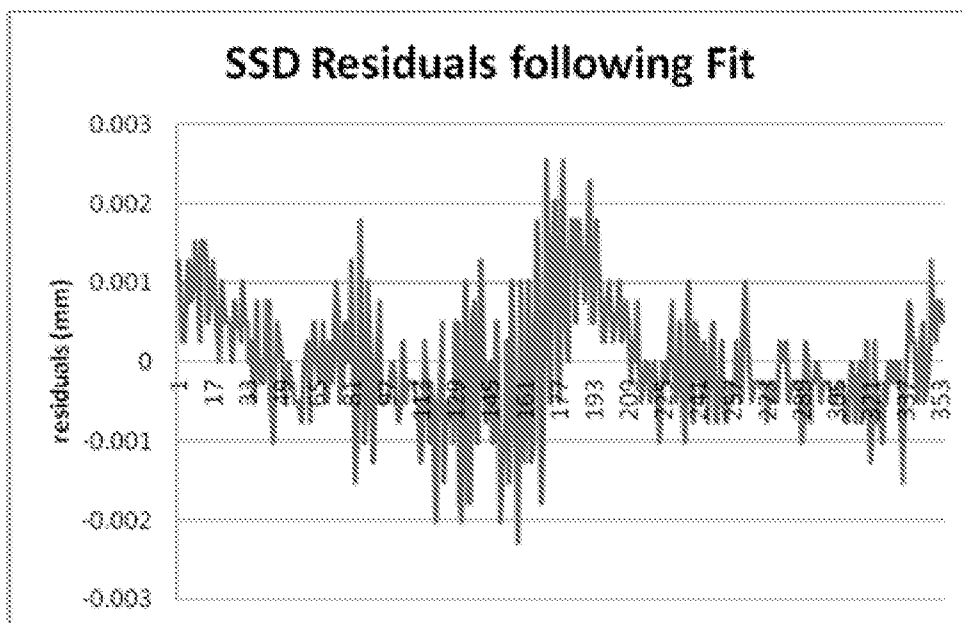

Fig. 6b

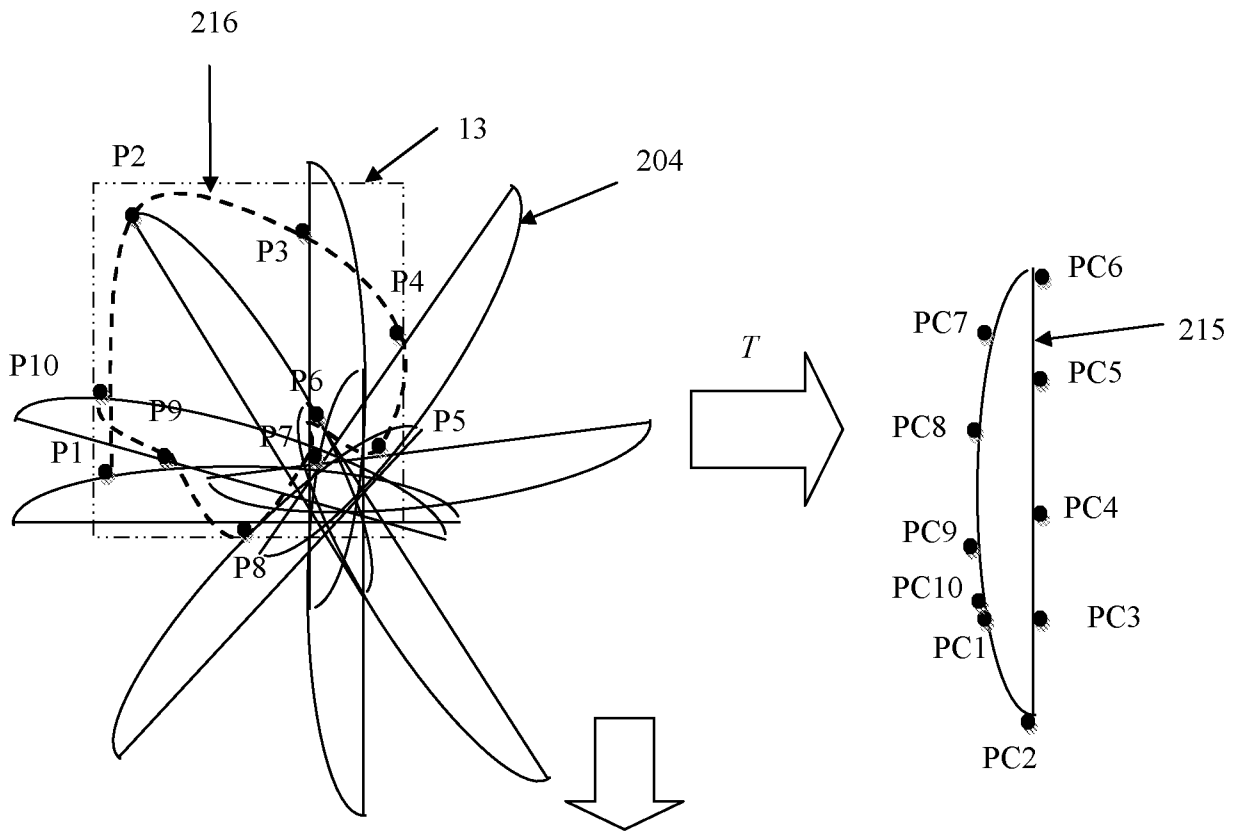

Fig. 7a

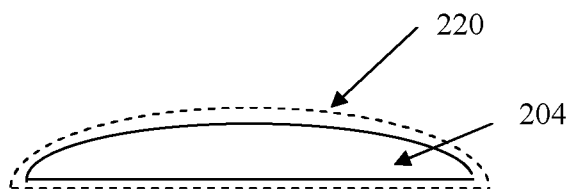

Fig. 7b

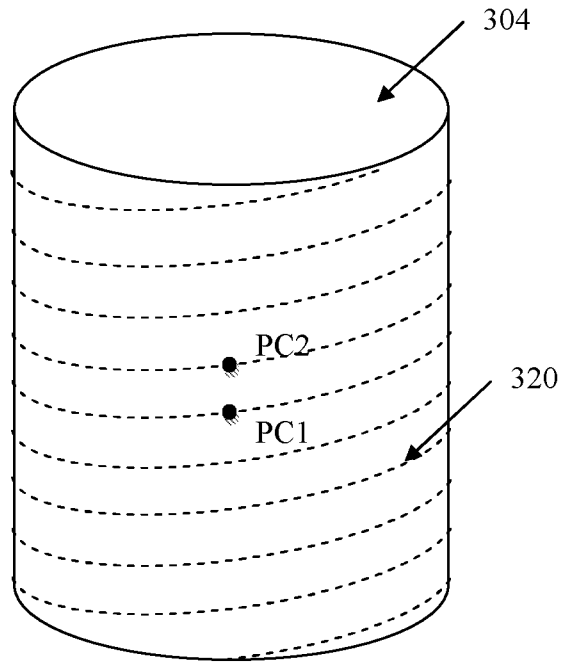

Fig. 8

# INTERNATIONAL SEARCH REPORT

International application No  
PCT/GB2014/050285

**A. CLASSIFICATION OF SUBJECT MATTER**

INV. G01B21/04      G01B5/10      G01B5/20      G05B19/401      G01B5/213  
ADD.

According to International Patent Classification (IPC) or to both national classification and IPC

**B. FIELDS SEARCHED**

Minimum documentation searched (classification system followed by classification symbols)  
G01B G05B B23Q

Documentation searched other than minimum documentation to the extent that such documents are included in the fields searched

Electronic data base consulted during the international search (name of data base and, where practicable, search terms used)

EPO-Internal, WPI Data

**C. DOCUMENTS CONSIDERED TO BE RELEVANT**

Category*	Citation of document, with indication, where appropriate, of the relevant passages	Relevant to claim No.
X	US 6 154 713 A (PETER HEINZ [DE] ET AL) 28 November 2000 (2000-11-28) cited in the application abstract; claim 1; figures 1-4 column 5, line 17 - column 9, line 36 -----	1-8,22, 25
X	US 5 204 824 A (FUJIMAKI SHIGERU [JP]) 20 April 1993 (1993-04-20) figures 2-7 column 3, line 16 - column 4, line 11 -----	1-8,22, 25
X	US 6 697 748 B1 (ROSENBERG LOUIS B [US] ET AL) 24 February 2004 (2004-02-24) abstract; figure 1 -----	1-8,22, 25

Further documents are listed in the continuation of Box C.

See patent family annex.

\* Special categories of cited documents :

- "A" document defining the general state of the art which is not considered to be of particular relevance
- "E" earlier application or patent but published on or after the international filing date
- "L" document which may throw doubts on priority claim(s) or which is cited to establish the publication date of another citation or other special reason (as specified)
- "O" document referring to an oral disclosure, use, exhibition or other means
- "P" document published prior to the international filing date but later than the priority date claimed

- "T" later document published after the international filing date or priority date and not in conflict with the application but cited to understand the principle or theory underlying the invention
- "X" document of particular relevance; the claimed invention cannot be considered novel or cannot be considered to involve an inventive step when the document is taken alone
- "Y" document of particular relevance; the claimed invention cannot be considered to involve an inventive step when the document is combined with one or more other such documents, such combination being obvious to a person skilled in the art
- "&" document member of the same patent family

Date of the actual completion of the international search

14 April 2014

Date of mailing of the international search report

07/07/2014

Name and mailing address of the ISA/

European Patent Office, P.B. 5818 Patentlaan 2  
NL - 2280 HV Rijswijk  
Tel. (+31-70) 340-2040,  
Fax: (+31-70) 340-3016

Authorized officer

Passier, Martinus

# INTERNATIONAL SEARCH REPORT

International application No.  
PCT/GB2014/050285

## Box No. II Observations where certain claims were found unsearchable (Continuation of item 2 of first sheet)

This international search report has not been established in respect of certain claims under Article 17(2)(a) for the following reasons:

1.  Claims Nos.:  
because they relate to subject matter not required to be searched by this Authority, namely:
  
2.  Claims Nos.:  
because they relate to parts of the international application that do not comply with the prescribed requirements to such an extent that no meaningful international search can be carried out, specifically:
  
3.  Claims Nos.:  
because they are dependent claims and are not drafted in accordance with the second and third sentences of Rule 6.4(a).

## Box No. III Observations where unity of invention is lacking (Continuation of item 3 of first sheet)

This International Searching Authority found multiple inventions in this international application, as follows:

see additional sheet

1.  As all required additional search fees were timely paid by the applicant, this international search report covers all searchable claims.
  
2.  As all searchable claims could be searched without effort justifying an additional fees, this Authority did not invite payment of additional fees.
  
3.  As only some of the required additional search fees were timely paid by the applicant, this international search report covers only those claims for which fees were paid, specifically claims Nos.:
  
4.  No required additional search fees were timely paid by the applicant. Consequently, this international search report is restricted to the invention first mentioned in the claims; it is covered by claims Nos.:  
1-8, 22, 25

### Remark on Protest

- The additional search fees were accompanied by the applicant's protest and, where applicable, the payment of a protest fee.
- The additional search fees were accompanied by the applicant's protest but the applicable protest fee was not paid within the time limit specified in the invitation.
- No protest accompanied the payment of additional search fees.

**FURTHER INFORMATION CONTINUED FROM PCT/ISA/ 210**

This International Searching Authority found multiple (groups of) inventions in this international application, as follows:

1. claims: 1-8, 22, 25

Measuring a plurality of points of a part with a contact probe on a coordinate positioning machine, wherein both the probe and the part move between a plurality of different positions within the coordinate positioning machine.

- Substantially coincident points that are closely located together along a curve or surface being measured are measured at relatively far apart positions in the machine.

---

2. claims: 9, 10, 23, 26

Measuring a plurality of points of a part with a contact probe on a coordinate positioning machine, wherein both the probe and the part move between a plurality of different positions within the coordinate positioning machine.

- Using a multi-axis contact probe, the motion between the probe and the part being such that the probe carries out the measurements through deflection of the stylus in at least two of the measurement directions.

---

3. claims: 11, 12, 14-21, 24, 27

Measuring a plurality of points of a part with a contact probe on a coordinate positioning machine, wherein both the probe and the part move between a plurality of different positions within the coordinate positioning machine.

- Fitting an analytical curve to the plurality of points to obtain a representation of the surface of the part.

---

4. claims: 13, 28-31

Measuring a plurality of points of a part with a contact probe on a coordinate positioning machine, wherein both the probe and the part move between a plurality of different positions within the coordinate positioning machine.

- Transforming each point in a common part coordinate system in which relative locations of the plurality of points on the part are defined based on a determined position of the part in the coordinate positioning machine when the point was measured.

---

# INTERNATIONAL SEARCH REPORT

Information on patent family members

International application No

PCT/GB2014/050285

Patent document cited in search report	Publication date	Patent family member(s)	Publication date
US 6154713	A	28-11-2000	DE 19712029 A1 24-09-1998
			EP 0866390 A1 23-09-1998
			JP 4326039 B2 02-09-2009
			JP H10300455 A 13-11-1998
			US 6154713 A 28-11-2000
-----			
US 5204824	A	20-04-1993	DE 4027339 A1 14-03-1991
			GB 2237661 A 08-05-1991
			JP H0384408 A 10-04-1991
			JP H07104146 B2 13-11-1995
			US 5204824 A 20-04-1993
-----			
US 6697748	B1	24-02-2004	US 6697748 B1 24-02-2004
			US 2004162700 A1 19-08-2004
-----			