

G. LITTLE.

Improvement in Automatic Telegraph Apparatus.

No. 133,235.

Patented Nov. 19, 1872.

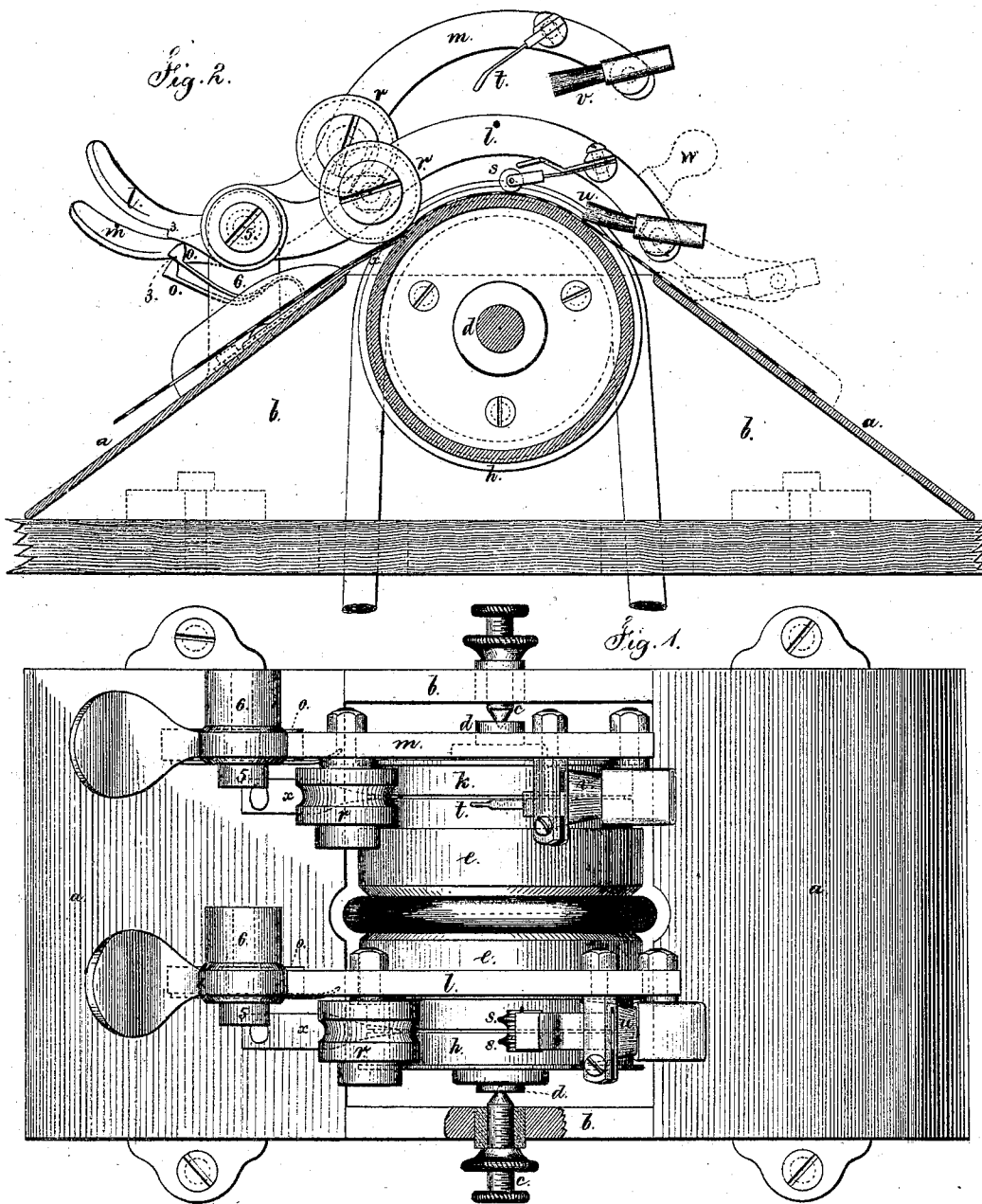

Chas. A. Smith

Harold Penell

Witnesses.

INVENTOR

George Little

Per. Lemuel W. Perrell

ATTY.

UNITED STATES PATENT OFFICE.

GEORGE LITTLE, OF RUTHERFORD PARK, NEW JERSEY.

IMPROVEMENT IN AUTOMATIC TELEGRAPHIC APPARATUS.

Specification forming part of Letters Patent No. 133,235, dated November 19, 1872.

To all whom it may concern:

Be it known that I, GEORGE LITTLE, of Rutherford Park, in the county of Bergen and State of New Jersey, have invented an Improvement in Telegraphic Apparatus, of which the following is a specification:

This instrument is adapted to sending pulsations by perforated paper, or receiving messages upon chemical paper, in the automatic system of telegraphing, and is designed more especially for local or branch offices.

A roller is made with two grooves or drums for strips of paper; one grooved drum is for the perforated transmitting-strip, and the other is for the chemical receiving-strip. Two hinged levers are provided, each with a pressure-spring, contact-roller, and guiding-brush, and one has the transmitting stylus or rollers, the other the recording stylus or pen. One of these levers is lifted when the other is depressed, and the circuit-connections are to the drum that is insulated and to the frame carrying the levers, so that whichever lever and stylus is depressed will be operative.

This instrument is strong, cheap, and compact.

In the drawing, Figure 1 is a plan of the instrument with the frame partially in section; and Fig. 2 is a side elevation, also partially in section.

The frame of the machine is made hollow, with inclined ends *a a*, and vertical sides *b b*. Through these sides *b b* are the insulated center screws *c*, sustaining the shaft *d* of the roller *e*, that may be of wood, metal, or other material, and contains a groove to receive a belt leading to a pulley or other convenient source of motive power, such as a hand-crank, fly-wheel, and treadle. The two grooves *h* and *k* form drums for the strips of paper, and levers *l m* are made each with a spring, *o*, to press the lever toward the drum or to hold up the same when turned back sufficiently for the spring to enter the notch 3, each lever being attached by a fulcrum-screw, 5, to the standard 6. Upon each lever is a roller, *r*, that serves to press the strip of paper to the drum, and insures the drawing of the same along when the drum is revolved. The lever *l* is provided with a transmitting stylus or roller, *s*, upon a spring-arm similar to that shown in

Letters Patent No. 122,473 granted to me. This arm is attached to the lever by a nut, so as to be adjustable. There may be one, two, or more of the rollers *s*. The lever *m* is provided with a stylus, *t*, for receiving and recording messages in connection with chemical paper. It is upon the end of a spring-arm connected to a clamp that is bolted adjustably to the lever *m*. Each lever, *l m*, carries a brush or yielding detainer, *u v*, of any suitable material, to straighten the paper and insure its proper contact with the surface of the drum. These brushes or detainers either act against the paper as it is upon the drum in the groove thereof, or else against the paper while in a trough cast in or attached to the inclined ends of the frame *a*, in which case the brushes *u v* will be positioned as shown by dotted lines in Fig. 2. If the roller *e* is made of metal the screw *c* should pass through insulated bearings, so that one wire can be attached to said screw *c*, and the other to the bed *a b*; but if the drums *h k* are insulated from the shaft, the connection may be made through insulated springs bearing against the surface of such drums. In either case the electric current will pass by the bed *a b* through whichever lever, *l* or *m*, may be turned down for operation; thence by the stylus *s* or *t* to the drum and its electric connections to the rheostat, line-wire, battery, condenser, or earth connection. The drums *h k* may be of cast-iron or other metal, plated, if desired, with nickel or other metal that can easily be kept clean. The drums *h k* may each be upon a short shaft, with a pulley of non-conducting material between them for the purpose of insulating the drums from each other, and to connect the drums to the pulley upon the same axial line. One end of each shaft may pass a short distance into said pulley and be secured so that the drums and pulley will revolve together. The strip of paper is easily introduced or removed by raising the lever and parts carried by it, and the lever that is not in use remains elevated. A handle may be provided for each lever *l m*, as shown at *w* by dotted lines. A clearing-finger, *x*, insulated and entering a groove in the drum, is employed to insure the delivery of the paper, as in my patent No. 123,491. The sides of the standards 6 next

the paper should be rounded, or sufficiently distant not to touch the paper. The trough for the strip of chemical paper, if cast with the end *a*, should be lined with mica for the paper to move over to prevent discoloration of the paper by contact with the metal of the trough.

I do not herein claim the roller, stylus, and brush, raised or lowered simultaneously, as the same is shown in Letters Patent No 129,840, granted to me.

I claim as my invention—

1. The lever (*l* or *m*) made with the thumb-piece and carrying the roller *r*, stylus, and brush or detainer, in combination with the spring *o*, the parts being constructed and ar-

ranged as specified, so that the lever may be raised and held up by the spring *o*, or the reverse, as set forth.

2. The two drums *h k* for the perforated and chemically-prepared strips of paper, mounted upon one shaft and revolved by a belt or equivalent, in combination with two levers carrying the rollers, stylus, and brush or detainer of the transmitting and receiving devices, substantially as set forth.

Signed by me this 20th day of July, A. D. 1872.

GEORGE LITTLE.

Witnesses:

CHAS. H. SMITH,
GEO. T. PINCKNEY.