

(19) World Intellectual Property
Organization
International Bureau



(43) International Publication Date
11 August 2005 (11.08.2005)

PCT

(10) International Publication Number
WO 2005/073489 A1

(51) International Patent Classification⁷: **E05B 63/08**,
65/06, 59/00, 13/00

(21) International Application Number:
PCT/AU2004/000107

(22) International Filing Date: 30 January 2004 (30.01.2004)

(25) Filing Language: English

(26) Publication Language: English

(71) Applicant (for all designated States except US): **ASSA
ABLOY AUSTRALIA PTY LIMITED** [AU/AU]; 50 Ed-
ward Street, Oakleigh, Victoria 3166 (AU).

(72) Inventor; and

(75) Inventor/Applicant (for US only): **BLANCH, David,
Garfield** [AU/AU]; 46 Westerfield Drive, Nottingham,
Victoria 3168 (AU).

(74) Agent: **CULLEN & CO.**; Level 26, 239 George Street,
Brisbane, Queensland 4000 (AU).

(81) Designated States (unless otherwise indicated, for every
kind of national protection available): AE, AG, AL, AM,

AT, AU, AZ, BA, BB, BG, BR, BW, BY, BZ, CA, CH, CN,
CO, CR, CU, CZ, DE, DK, DM, DZ, EC, EE, EG, ES, FI,
GB, GD, GE, GH, GM, HR, HU, ID, IL, IN, IS, JP, KE,
KG, KP, KR, KZ, LC, LK, LR, LS, LT, LU, LV, MA, MD,
MG, MK, MN, MW, MX, MZ, NA, NI, NO, NZ, OM, PG,
PH, PL, PT, RO, RU, SC, SD, SE, SG, SK, SL, SY, TJ, TM,
TN, TR, TT, TZ, UA, UG, US, UZ, VC, VN, YU, ZA, ZM,
ZW.

(84) Designated States (unless otherwise indicated, for every
kind of regional protection available): ARIPO (BW, GH,
GM, KE, LS, MW, MZ, SD, SL, SZ, TZ, UG, ZM, ZW),
Eurasian (AM, AZ, BY, KG, KZ, MD, RU, TJ, TM), Euro-
pean (AT, BE, BG, CH, CY, CZ, DE, DK, EE, ES, FI, FR,
GB, GR, HU, IE, IT, LU, MC, NL, PT, RO, SE, SI, SK,
TR), OAPI (BF, BJ, CF, CG, CI, CM, GA, GN, GQ, GW,
ML, MR, NE, SN, TD, TG).

Published:

- with international search report
- with amended claims

For two-letter codes and other abbreviations, refer to the "Guid-
ance Notes on Codes and Abbreviations" appearing at the begin-
ning of each regular issue of the PCT Gazette.

(54) Title: A THREE MODE LOCK

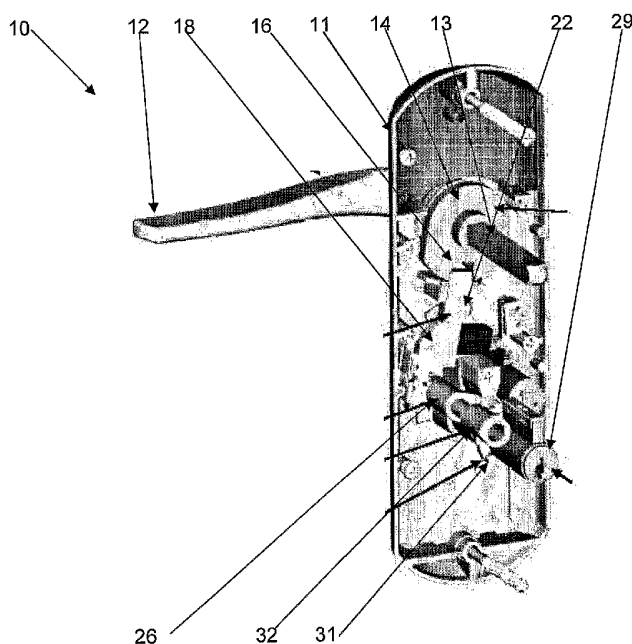

(57) Abstract: A door lock (10) having a lock body (11), an external handle and an internal handle (12), a rotatable interconnecting member (13) to interconnect the internal handle and the external handle, and a mechanism to allow the lock to have a passage mode, and a privacy mode and a deadlock mode, in one embodiment the mechanism comprises an outer hub (14) and an internal hub (15) which are inside the lock body, in a second embodiment a remote control means is provided to allow at least some of the modes to be operated manually or by remote control.

WO 2005/073489 A1

A THREE MODE LOCK

FIELD OF THE INVENTION

This invention is directed to a lock and in particular to a front door lock which contains a particular mechanism which allows the lock to be a "three mode lock" by which is meant that the lock can have a passage mode, a privacy mode, and a deadlock mode. The lock may be a mechanical lock or an electromechanical lock whereby the lock can be operated using a remote signal device.

BACKGROUND ART

Locks, and particularly door locks, can function in a number of different modes. One known mode is a passage mode. The passage mode is a mode where the door can be opened from the inside and the outside by turning the door handle, and there is no mechanism to lock either side of the door. These types of locks are widely used in houses.

Another known mode is a privacy mode. In the privacy mode, the door can be locked from the outside by turning a snib or similar type of member on the inside of the door. The door can be opened from the inside, either by turning a snib, or by simply turning the handle which overrides the locking mechanism to allow the door to be opened from the inside. However, the door is locked from the outside. This type of mode is widely used in bathroom doors and some front doors.

Another known mode is a deadlock mode. In the deadlock mode the door is locked from the inside and from the outside and usually requires a key to open the door. Deadlocking locks are very common and are widely used on front doors.

Locks are known which combine at least some of the above modes. For instance, locks are known which combine the privacy mode and the deadlocking mode. Other types of combination locks are also known.

Locks which combine all three of the above modes are not very well-known. Moreover, such locks can be quite complicated in design. Often, the design of these locks is not very secure and the locks can be manipulated or forced into a position where an intruder can gain access through the door.

More recently, there has been a desire to provide remote control locks, and particularly remote control door locks. The remote control door locks need to contain some form of mechanism to allow the lock to be operated by a remote signal. To date, there has been no multiple mode lock which has a remote control mechanism

which can be built into the lock, or a multiple mode lock which may be manual in operation but which can be adapted for remote control with minimum reconfiguration of the lock.

It will be clearly understood that, if a prior art publication is referred to herein, this reference does not constitute an admission that the publication forms part of the common general knowledge in the art in Australia or in any other country.

OBJECT OF THE INVENTION

It is an object of the invention to provide a multiple mode lock which may overcome at least part of the above-mentioned disadvantages or provide the consumer with a useful or commercial choice.

In one form, the invention resides in a lock which contains a mechanism to allow the lock to have a passage mode, and/or a privacy mode and/or a deadlock mode.

In another form, the invention resides in a remote control lock which contains a mechanism to allow the lock to have a passage mode and/or a privacy mode and/or a deadlock mode, and remote control means to allow at least some of the modes to be operated by remote control.

The lock will typically comprise a front door lock although the invention need not be limited to this particular use. The front door may comprise a swing door although the invention need not be limited to this particular type of door.

The lock will typically have an external handle (that is, a handle on the outside of the door) and an internal handle (that is, on the inside of the door). The handle may comprise a knob, a lever handle, or any other type of suitable handle. Indeed, the handle may comprise a snib like handle and the like.

The lock will typically have a lock body which supports at least some of the mechanism. Typically, the lock body includes an interconnecting member to interconnect the internal handle with the external handle. The interconnecting member typically comprises a connecting bar which is typically square in cross-section, this type of connecting bar being well-known. It is well-known to provide a lock tongue which is operatively associated with the connecting bar such that rotation of the connecting bar about its longitudinal axis will cause retraction or extension of the lock tongue.

The lock may contain an outer hub and an internal hub. Each hub is

typically positioned within the lock body and can form part of the lock mechanism. Suitably, the outer hub and the internal hub are positioned next to each other with the internal hub being positioned behind the outer hub and between the outer hub and the lock body. The outer hub and/or the internal hub may be substantially planar in configuration and may comprise members which are adapted for rotation in the lock body. Suitably, the outer hub is attached to, or relative to, the connecting bar such that rotation of the connecting bar causes rotation of the outer hub. Typically, this is achieved by providing a square passageway through the outer hub to allow the outer hub to be fixed to the connecting bar such that rotation of the connecting bar rotates the outer hub. Of course, other types of attachments are envisaged.

The internal hub is typically operatively associated with the internal handle such that rotation of the internal handle causes rotation of the internal hub. Various types of cooperative attachments of the internal handle to the internal hub are envisaged. The attachment of the internal hub is preferably such that the internal hub moves or rotates upon movement of the internal handle, but the internal hub does not necessarily move or rotate upon rotation of the external handle.

The internal hub and the outer hub are typically provided with engagement means to allow the internal hub and the outer hub to engage with a locking bar. The engagement means may comprise a simple recess or cutout portion in each hub although other types of engagement means are envisaged such as abutments, profiles and the like.

The lock mechanism may include a locking bar. The locking bar may be movable between a locking position where the locking bar engages with the outer hub and/or the internal hub, and a free position where the locking bar does not engage with the outer hub and/or the internal hub. The locking bar may be movable between the locking position and the free position in a sliding manner, a rotating manner, a combination of a sliding and rotating manner and the like. The locking bar may be substantially plate like in configuration and may contain a nose portion which is adapted for engagement with the internal hub and the outer hub. The term "locking bar" is to be considered broadly and may comprise other types of locking members or locking means which can function or operate in a manner identical or similar to that described above.

The lock may comprise a mechanism to allow it to move between a

passage mode and a privacy mode. The mechanism may comprise the internal hub, the outer hub and the locking bar as described above. Suitably, when in the passage mode, the locking bar is in the free position enabling the lock to be opened from either side of the door. Suitably, when in the privacy mode, the locking bar is in the locking position which prevents operation of the external handle but still allows operation of the internal handle.

The locking bar may be movable between its locking position and its free position by an external member. The external member may comprise a snib mechanism. The snib mechanism may comprise an external snib on the outside of the lock and which can be manipulated to move the locking bar between the locking position and the free position.

The snib mechanism may be operatively connected to the locking bar. In one form, the snib mechanism may comprise a rotatable member containing an eccentric pin which is attached to the locking bar such that a "crank type" type mechanism is provided whereby rotation of the external snib causes reciprocal movement of the locking bar. Of course, other types of mechanisms are envisaged which may provide a similar or identical function. For instance, the external member may comprise a slide member which can slide the locking bar between the locking position and the free position.

When in the privacy mode, it is preferred that operation of the internal handle can cause the locking bar to move from the locking position to the free position (i.e. a kickback function). In one form, this can be achieved by providing an inclined surface or a ramped surface on the internal hub which may form part of the engagement means of the locking bar to the internal hub. The construction and arrangement may be such that rotation of the internal hub (by rotation of the internal handle) causes the inclined surface to engage with the nose portion of the locking bar to push the locking bar out of engagement with the internal hub (i.e. return the locking bar to the free position). Thus, when in the privacy mode, the internal handle can be operated to move the locking bar back to the free position; however the external handle is prevented from doing so.

The lock may contain a lock barrel (cylinder). Suitably, the lock contains two lock barrels being an external lock barrel (external cylinder) and an internal lock barrel (internal cylinder). The internal cylinder may be key operated

from the inside of the door and the external cylinder may be key operated from the outside of the door. Each cylinder is typically associated with a cam (this being conventional) and the cam is typically attached to the inner end of the cylinder. The cam usually contains a camming member which rotates upon insertion and rotation of a key into the cylinder.

Suitably, the lock is provided with an internal cylinder which is operatively associated with the locking bar. Thus, operation of the internal cylinder can operate the locking bar between the locking position and the free position. It is also preferred that the internal cylinder can deadlock the locking bar into the locking position by which is meant that the locking bar is unable to move to the free position unless the internal cylinder is unlocked by the key. Thus, it is possible for the lock to be deadlocked from the inside of the door.

In one form, a first drive member is provided to drive the locking bar between the locking position and/or the free position. The drive member may be rotatable. The drive member may be operated by the cam of the internal cylinder such that insertion and rotation of a key in the internal cylinder causes rotation of the internal cam which, in turn, operates the drive member to move the locking bar between the locking position and the free position. However, other types of mechanisms are envisaged to allow the internal cylinder to manipulate the locking bar.

Suitably, the above mechanism allows the lock to move from a passage mode to a privacy mode and a deadlock mode from the inside of the door. Movement from the passage mode to the privacy mode and vice versa may be available using the snib and movement from the passage mode to the privacy mode and the deadlock mode may be available using the internal cylinder.

The lock may contain a mechanism to allow at least some of the modes to be selected from the outside of the door. It is preferred that the lock contains a mechanism or means to allow the lock to operate between the deadlock mode, the privacy mode and the passage mode from the outside of the door.

In one form, this can be achieved by providing an external cylinder. The external cylinder may contain a cam such that insertion and rotation of the key in the external cylinder causes rotation of the cam. The cam (which can be called the external cam as it is attached to the external cylinder) may be operatively associated with the locking bar such that operation of the external cylinder can move the locking

bar between the locking position and the free position and/or can also deadlock the locking bar in the locking position. In one form, this can be achieved by providing a second drive member which can be operatively associated with the external cam such that rotation of the external cam causes rotation of the second drive member. The second drive member may be operatively associated with the first drive member such that rotation of the second drive member causes rotation of the first drive member, and, as the first drive member may be associated with the locking bar, this can cause the locking bar to move from its unlocking position to its locking position and vice versa. However, other mechanisms or means are envisaged which may allow the external cylinder to be operatively associated with the locking bar.

The lock may comprise a remote control lock such that at least some of the lock modes can be operated from a position remote to the lock. Suitably, the remote control allows the lock to move between the passage mode and the privacy mode.

Suitably, a signal generating means is provided to allow the lock to be operated between various lock modes. The signal generating means may comprise a small portable device which can be attached to a key ring etc. The signal itself may be of various types including a radio signal, an infrared signal, and the like (Proximity cards, fingerprint or keypads). The signal may be coded.

The lock may contain a receiver to sense the signal generating means. The receiver may comprise or include a microswitch. The lock may include a drive means. The drive means may comprise a motor or solenoid, which is typically a small electric motor. The drive means may be controlled by the microswitch. The drive means is typically operatively associated with the locking bar such that operation of the drive means can move the locking bar between the locking position and the unlocking position. It is envisaged that there will be various ways of operatively associating the drive means with the locking bar. In one form, their may be provided a drive member which moves the locking bar between the locking position and the free position. The drive member may be driven by the electric motor.

BRIEF DESCRIPTION OF THE DRAWINGS

Embodiments of the invention will be described with reference to the following drawings in which :

Figure 1. Illustrates the internal components of the lock from one side and

particularly illustrates the outer hub.

Figure 2. Illustrates the internal components of the lock of Figure 1 from the other side but with removal of the outer hub to more clearly illustrate the internal hub.

Figure 3. Illustrates a close up view of the locking bar, the outer hub, and the
5 internal snib mechanism to operate the locking bar.

Figure 4. Illustrates a close up view of the lower area of the lock bar and particularly illustrates the internal cam and the first drive member.

Figure 5. Illustrates a close up view of the external cylinder.

Figure 6. Illustrates a close up view of Figure 5 but from one side and
10 particularly illustrates the external cam and the second drive member.

Figure 7. Illustrates the remote control components of the lock and particularly illustrates the drive member which drives the locking bar.

Figure 8. Illustrates the remote control components of the lock and particularly illustrates the electric motor.

15

BEST MODE

Referring to the drawings and initially to figures 1 and 2, there is illustrated the components of the lock and according to an embodiment only of the invention. Lock 10 in the embodiment comprises a front door lock. Lock 10 has a lock body 11 to house the various internal components, an internal handle 12 (by
20 which is meant that handle 12 is on the inside of the door), and various internal components which will be described in greater detail below. Not illustrated for reasons of clarity is an external handle , and a plate which would be similar to lock body 11 and which sits on the outside of the door.

The internal handle 12 and the external handle (not illustrated) are
25 connected together in the normal manner by a connecting bar 13 which is typically substantially square in cross-section. A lock tongue assembly (not illustrated but of a conventional design) is operatively associated to connecting bar 13 such that rotation of connecting bar 13 (by operation of the internal handle 12 or the external handle) causes the lock tongue to move between a retracted position (to allow the door to
30 open) and an extended position where the lock tongue enters into a keeper to prevent the door from opening. This arrangement is quite conventional.

The lock mechanism contains an outer hub 14 and an internal hub 15. Figure 1 particularly illustrates outer hub 14 while figure 2 has the outer hub 14

removed to illustrate the inner hub 15. Thus, outer hub 14 and internal hub 15 are positioned next to each other with the internal hub 15 being positioned behind outer hub 14 and between outer hub 14 and lock body 11. Outer hub 14 is substantially plate like and is also substantially round and contains a cutout portion 16. Importantly, cutout portion 16 contains substantially parallel sidewalls such that the cutout portion is substantially U-shaped. This means that there is no inclined wall or ramped portion in cutout portion 16 of outer hub 14. The reason for this will be described below. Outer hub 14 is attached to bar 13 in such a manner that rotation of bar 13 causes rotation of hub 14. In the particular embodiment, this is achieved by having a square opening extending through outer hub 14 to allow it to slide over the top of bar 13 but prevents independent rotation of hub 14 relative to bar 13.

Referring to internal hub 15 (best illustrated in figure 2), this hub is also substantially plate like and somewhat rounded and also contains a cutout portion 17. However, the cutout portion 17 of internal hub 15 has inclined sidewalls 18 at the front of the cutout portion. Also, internal hub 15 is connected relative to handle 12 such that rotation of handle 12 causes rotation of internal hub 15. However, internal hub 15 is not directly attached to bar 13.

A locking bar 18 is provided in the lock. The locking bar 18 is substantially plate like and contains a nose portion 19 which is configured to enable it to pass at least partially within the cutout portion on the outer hub and the cutout portion on the internal hub. The locking bar 18 is slidingly movable between a forward locking position where the nose portion passes into the cutout portion and a retracted free position where the nose portion does not engage with the outer hub or the internal hub.

When the locking bar 18 is in the forward locking position (see figure 1), the nose portion is within the cutout portion of the outer hub 14. In this position, the external handle (not illustrated) cannot be rotated to retract the lock tongue (not illustrated) as bar 13 cannot be rotated because outer hub 14 is locked against rotation by locking bar 18. In this position, locking bar 18 is also in the cutout portion 17 of internal hub 15 this being best illustrated in figure 2. However, because cutout portion 17 has the inclined sidewalls 18, rotation of internal hub 15 will cause nose portion 17 to ride along the inclined sidewalls 18 to cause retraction of the locking bar back to the free position. Put differently, rotation of internal hub 15 can cause the

locking bar 18 to be kicked away from engagement with the internal hub and the outer hub. The configuration of the cutout portion in the outer hub and the internal hub is such that as the locking bar is kicked away from engagement with the internal hub, it will also retract out of the outer hub.

5 The internal hub 15 can be rotated by internal handle 12 as the internal hub is connected to or relative to handle 12. Thus, even when locking bar 18 is in the forward locking position, the internal handle can be rotated to "kick out" the locking bar from engagement with the internal hub and the outer hub which then allows the door to be opened. At this stage, the external handle can be operated to open the door
10 and the lock is in the "passage mode".

Conversely, when the locking bar is in engagement with the outer hub and the internal hub, the lock is in the "privacy mode" which means that the door cannot be operated from the outside but can still be opened from the inside.

Locking bar 18 can be moved from the free position to the locking
15 position by an external mechanism which in the particular embodiment comprises a snib mechanism 20. The snib mechanism 20 contains an internal snib (by which is meant that the snib is on the inside of the door and typically below internal handle 12 and can be operated by a person). The internal snib is connected to a rotatable member 21 which is inside the lock and which contains an eccentric pin 22 to form a
20 "crank" arrangement (see figure 3). Eccentric pin 22 is attached to locking bar 18 below nose portion 19. Thus, rotation of the snib will cause rotation of eccentric pin 22 which in turn will slide locking bar 18 from the retracted unlocking position to the extended locking position (the extended locking position being illustrated in figure 1 and figure 2).

25 In use, the door can be closed and a person on the inside of the door can manipulate the snib to make the lock adopt the "privacy mode". When in the privacy mode, the door can be returned to the passage mode either by rotation of the internal handle 12 which will kick out locking bar 18, or alternatively by manipulating the snib to retract the locking bar back into the free position.

30 The lock according to the particular embodiment is also able to adopt a deadlock position from the inside of the door. In the deadlock position, locking bar 18 is held in the locking position and is not able to be retracted to the free position by rotation of internal handle 12. Figure 4 illustrates some detail of the mechanism

which allows the lock to be deadlocked from the inside of the door. Specifically, an internal cylinder 23 is provided which is operated by a key. The internal cylinder extends through lock body 11 such that a key can be inserted into the internal cylinder 23 from the inside of the door. The inner end of internal cylinder 23 is attached to an internal cam 24 (this being quite conventional). The internal cam 24 is typically
5 screwed to the inner end of internal cylinder 23 and contains a camming member 25. Insertion of a key into internal cylinder 23 and rotation of the key causes rotation of the camming member 25.

Adjacent internal cam 24 is a first drive member 26. First drive
10 member 26 is best illustrated in figure 4. The first drive member 26 is mounted for rotation and contains a pair of lobes 27 which function to abut against camming member 25. Thus, rotation of camming member 25 in a clockwise or anticlockwise manner will ultimately cause the camming member 25 to strike one of the lobes 27 which will cause rotation of drive member 26. Drive member 26 engages with a
15 lower part of locking bar 18 in the manner illustrated in figure 4. Thus, anticlockwise rotation of drive member 26 will cause retraction of locking bar 18 while clockwise rotation of drive member 26 will cause extension of locking bar 18. In this way, insertion and turning of a key in internal cylinder 23 can cause locking and unlocking of locking bar 18. However, when the locking bar has been moved to the locking
20 position, removal of the key from internal cylinder 23 will cause the camming member 25 to remain in engagement with one of the lobes 27. The camming member 25 cannot rotate as the key has been removed from internal cylinder 23. Consequently, the first drive member 26 cannot rotate either which means that locking bar 18 cannot be retracted. Thus, the lock is now in the deadlock mode and the
25 internal handle and the external handle cannot be rotated, the internal snib cannot be moved, and the door cannot be opened unless the key is reinserted into internal cylinder 23 and rotated to free camming member 25 from engagement against the first drive member 26.

In the particular embodiment, the lock also has an external cylinder 29
30 which is illustrated in figure 1 and figure 2. The external cylinder also allows the lock to be deadlocked and also allows the lock to move from the deadlock mode to the privacy mode and the passage mode. This is achieved as follows: the external cylinder 29 also contains a cam 30 attached to the inner end of the external cylinder,

and cam 30 is best illustrated in figure 6. In figure 6, only cam 30 has been illustrated and the external cylinder has been removed for reasons of clarity. Cam 30 has a camming member 31 and adjacent cam 30 is a second drive member 32. Drive member 32 contains a pair of lobes 33 similar to that of first drive member 26, and camming member 31 strikes one of the lobes to cause rotation of second drive member 32. Thus, a key can be inserted into external cylinder 29 and turned to rotate cam 30 to cause second drive member 32 to rotate either in a clockwise direction or an anticlockwise direction. Second drive member 32 is attached to a shaft 34 which extends from first drive member 26 the shaft being best illustrated in figure 6.

10 Rotation of second drive member will therefore cause corresponding rotation of the first drive member 26 and as the first drive member 26 engages with locking bar 18, rotation of second drive member 32 will also cause movement of locking bar 18 through the first drive member 26.

The lock can therefore be manipulated from the privacy mode and the deadlock mode by an external key passing into external cylinder 29. Again, when in the deadlock mode (that is when camming member 31 prevents rotation of second drive member 32 which in turn prevents rotation of first drive member 26 which in turn prevents retraction of locking bar 18), neither the internal handle, the external handle or the snib can be manipulated to unlock the door.

20 The lock can also be adapted for remote control, and an advantage of the invention is that the lock can be converted from a mechanical lock as described above to a remote control lock as will be described below without large changes to the lock components.

Figure 7 and 8 illustrates the remote control version of the lock. Referring initially to figure 7, there is illustrated the lower part of locking bar 18 which is manipulated by first drive member 26 the first drive member 26 being operated by the internal cylinder 24. Locking bar 18 contains a pair of spaced apart recesses 36, 37. Locking bar 18 can be moved from its locking position to its unlocking position by a drive member 38 which contains an extending pin 39 which can engage in either recesses 36 or recess 37 depending on whether drive member 38 is rotated in a clockwise manner or an anticlockwise manner. Drive member 38 can also adopt a "free" position where pin 39 is spaced above recess 36 and recess 37 and does not engage either said recess. The drive member 38 can be rotated such that pin

25
30

39 engages in one said recess and continued rotation causes the pin to either pull locking bar 18 into the retracted position or extend locking bar 18 into the locking position.

5 Drive member 38 is operatively driven by a small electric motor 40 (see figure 8). Motor 40 contains a drive shaft in the form of a worm 41 (in figure 7 worm 41 is illustrated and the motor 40 has been removed for clarity). Worm 41 meshes with a number of gears 42, the arrangement being that activation of the small electric motor 40 can cause drive member 38 to either rotate in a clockwise manner or an anticlockwise manner as the case may be.

10 A microswitch 43 is provided to signal motor 40. An overload detection may be provided to prevent overloading the remote control components of the lock. The overload/microswitch provides position sensing as to the locking bar

Thus, the lock can be activated between the passage mode and the privacy mode by remote control if desired.

15 It should be appreciated that various other changes and modifications can be made to any embodiment described without departing from the spirit and scope of the invention.

CLAIMS:

1. A door lock having a lock body, an external handle and an internal handle, a rotatable interconnecting member to interconnect the internal handle and the external handle, and a mechanism to allow the lock to have a passage mode, and/or a
5 privacy mode and/or a deadlock mode, the mechanism comprising an outer hub and an internal hub which are inside the lock body.
2. The lock of claim 1, wherein the outer hub and the internal hub are positioned next to each other with the internal hub being positioned behind the outer hub and between the outer hub and the lock body.
- 10 3. The lock of claim 2, wherein the outer hub and the internal hub are substantially planar in configuration and comprise members which are adapted for rotation in the lock body.
4. The lock of claim 2, wherein the outer hub is attached to the interconnecting member such that rotation of the interconnecting member causes
15 rotation of the outer hub.
5. The lock of claim 4, wherein the internal hub is operatively associated with the internal handle such that rotation of the internal handle causes rotation of the internal hub.
6. The lock of claim 5, comprising engagement means on the internal hub
20 and the outer hub to allow the internal hub and the outer hub to engage with a locking bar.
7. The lock of claim 6, wherein the engagement means comprises a recess in each hub.
8. The lock of claim 1, comprising a locking bar which is movable
25 between a locking position where the locking bar engages with the outer hub and/or the internal hub, and a free position where the locking bar does not engage with the outer hub and/or the internal hub.
9. The lock of claim 8, wherein the locking bar is movable between the locking position and the free position in a sliding manner or a rotating manner or a
30 combination of a sliding and rotating manner.
10. The lock of claim 9, wherein the locking bar is substantially plate like in configuration and contains a nose portion which is adapted for engagement with the internal hub and the outer hub.

11. The lock of claim 8, wherein the mechanism to allow the lock to operate between a passage mode and a privacy mode comprises the internal hub, the outer hub and the locking bar.
12. The lock of claim 11 wherein when the mechanism is in the passage mode, the locking bar is in the free position enabling the lock to be opened from either side of the door.
13. The lock of claim 12, wherein when the mechanism is in the privacy mode, the locking bar is in the locking position which prevents operation of the external handle but still allows operation of the internal handle.
14. The lock of claim 8, wherein the locking bar is movable between its locking position and its free position by an external member.
15. The lock of claim 14, wherein the external member is a snib mechanism which comprises an external snib on the outside of the lock which can be manipulated to move the locking bar between the locking position and the free position.
16. The lock of claim 15, wherein the snib mechanism comprises a rotatable member containing an eccentric pin which is attached to the locking bar such that a crank type mechanism is provided whereby rotation of the external snib causes reciprocal movement of the locking bar.
17. The lock of claim 16, wherein when the mechanism is in the privacy mode, operation of the internal handle causes the locking bar to move from the locking position to the free position.
18. The lock of claim 17, wherein the internal hub has a recess formed with a ramped surface whereby rotation of the internal causes the inclined surface to engage with the nose portion of the locking bar to push the locking bar out of engagement with the internal hub.
19. The lock of claim 8, comprising at least one lock cylinder.
20. The lock of claim 19 comprising two lock cylinders being an external lock cylinder and an internal lock cylinder the internal cylinder being key operated from the inside of the door and the external cylinder being key operated from the outside of the door.
21. The lock of claim 20, wherein the internal cylinder is operatively associated with the locking bar such that operation of the internal cylinder operates the

locking bar between the locking position and the free position.

22. The lock of claim 21, wherein the internal cylinder deadlocks the locking bar into the locking position.

23. The lock of claim 21, comprising a first drive member to drive the
5 locking bar between the locking position and/or the free position.

24. The lock of claim 23, wherein the internal cylinder has a cam, and the drive member is rotatable and is operated by the cam of the internal cylinder such that insertion and rotation of a key in the internal cylinder causes rotation of the internal cam which in turn operates the drive member to move the locking bar between the
10 locking position and the free position.

25. The lock of claim 20 comprising a mechanism to operate the lock between the deadlock mode, the privacy mode and the passage mode from the outside of the door, the mechanism comprising the external cylinder which has a cam, the cam being rotated upon insertion and rotation of the key in the external cylinder, the cam
15 being operatively associated with the locking bar such that operation of the external cylinder moves the locking bar between the locking position and the free position and/or also deadlocks the locking bar in the locking position.

26. The lock of claim 25, comprising a second drive member which is operatively associated with the external cam such that rotation of the external cam
20 causes rotation of the second drive member.

27. The lock of claim 26, wherein the second drive member is operatively associated with the first drive member such that rotation of the second drive member causes rotation of the first drive member and, as the first drive member may be associated with the locking bar, to cause the locking bar to move from its unlocking
25 position to its locking position and vice versa.

28. The lock of claim 1 comprising a motor in the lock body to operate components in the lock body.

29. The lock of claim 28, wherein the motor is actuated by a remote control means.

30. The lock of claim 29, wherein the lock comprises a receiver to sense the remote control means.

31. The lock of claim 30, wherein the motor is operatively associated with the locking bar such that operation of the motor moves the locking bar between the

locking position and the unlocking position.

32. A remote control lock which contains a mechanism to allow the lock to have a passage mode and/or a privacy mode and/or a deadlock mode, and remote control means to allow at least some of the modes to be operated by remote control.

AMENDED CLAIMS

[(received by the International Bureau on 08 March 2005 (08.03.05);
new claim 33 added; remaining claims unchanged (1 page)]

32. A remote control lock which contains a mechanism to allow the lock to have a passage mode and/or a privacy mode and/or a deadlock mode, and remote control means to allow at least some of the modes to be operated by remote control.
- 5 33. A lock containing three separate modes being a deadlock mode, a privacy mode and a passage mode.

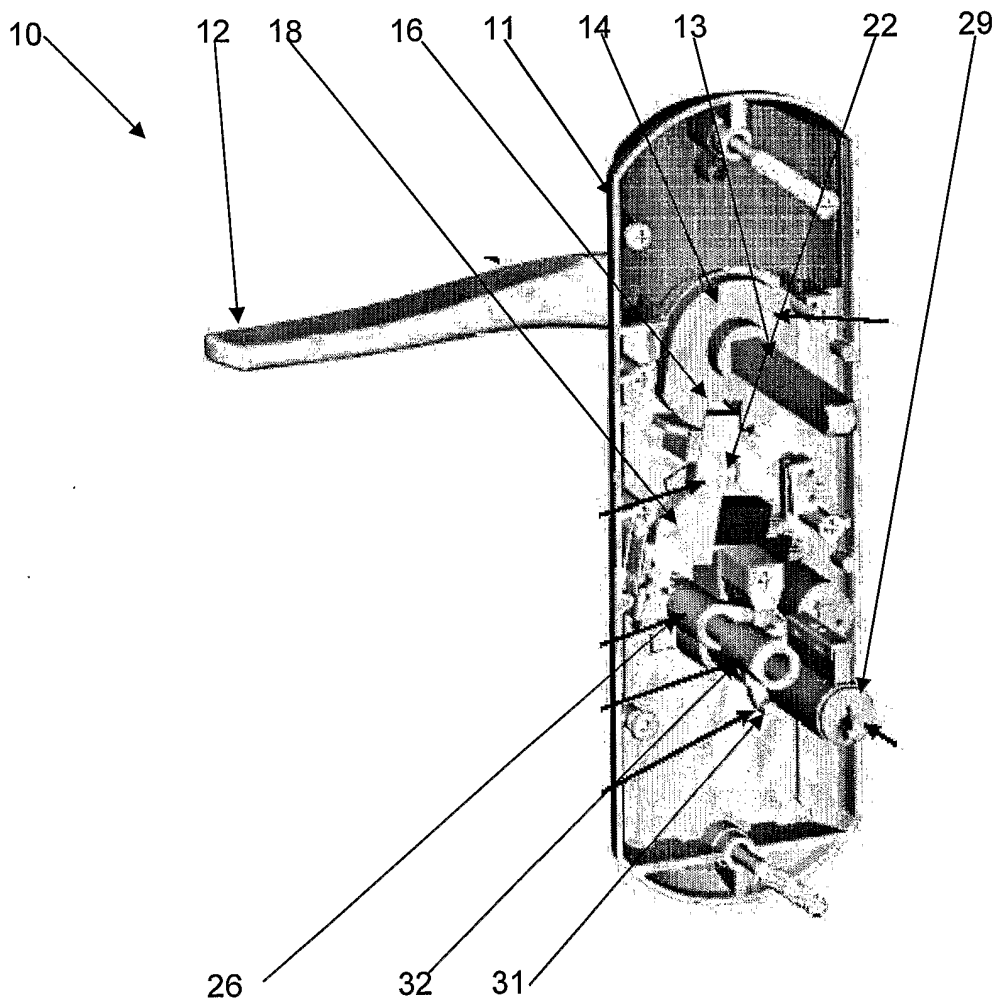

FIG 1

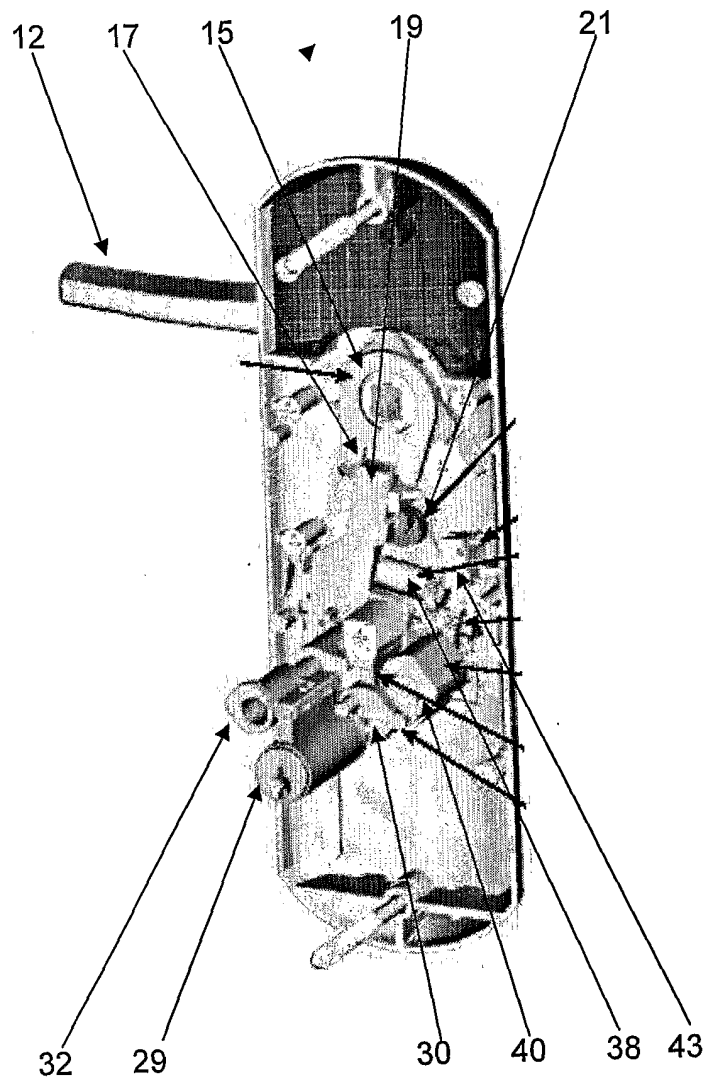

FIG 2

3/5

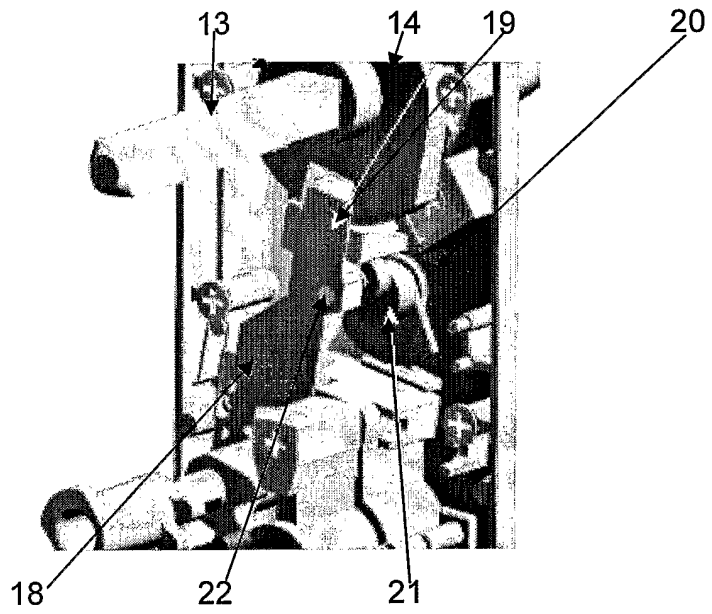

FIG 3

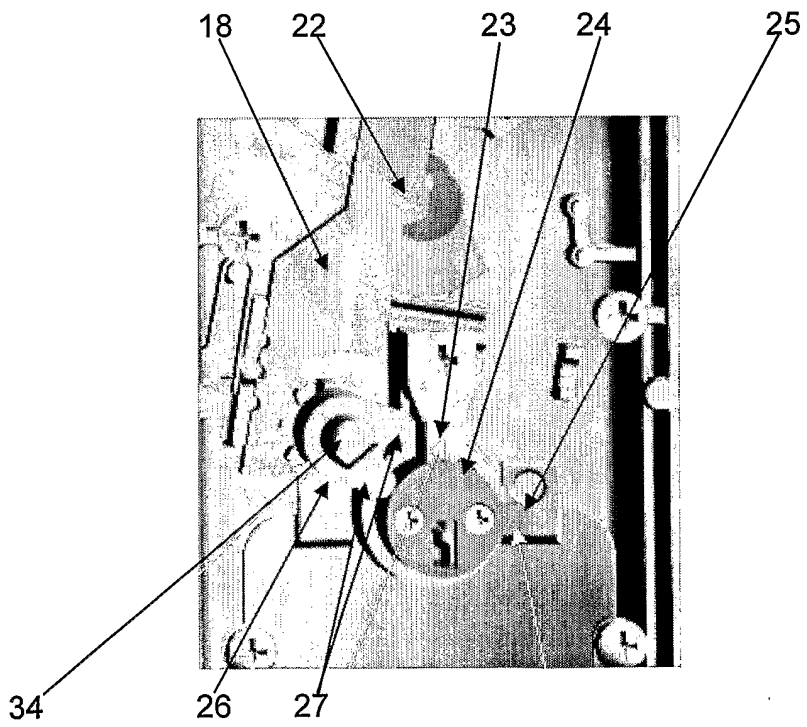

FIG 4

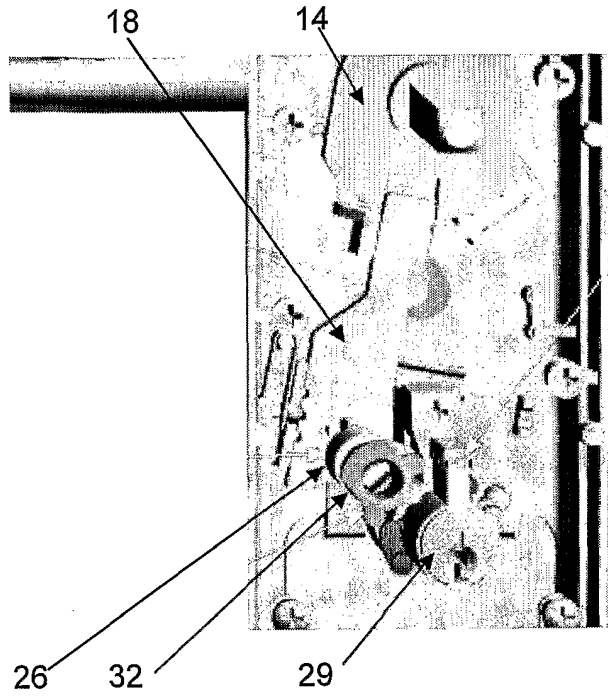

FIG 5

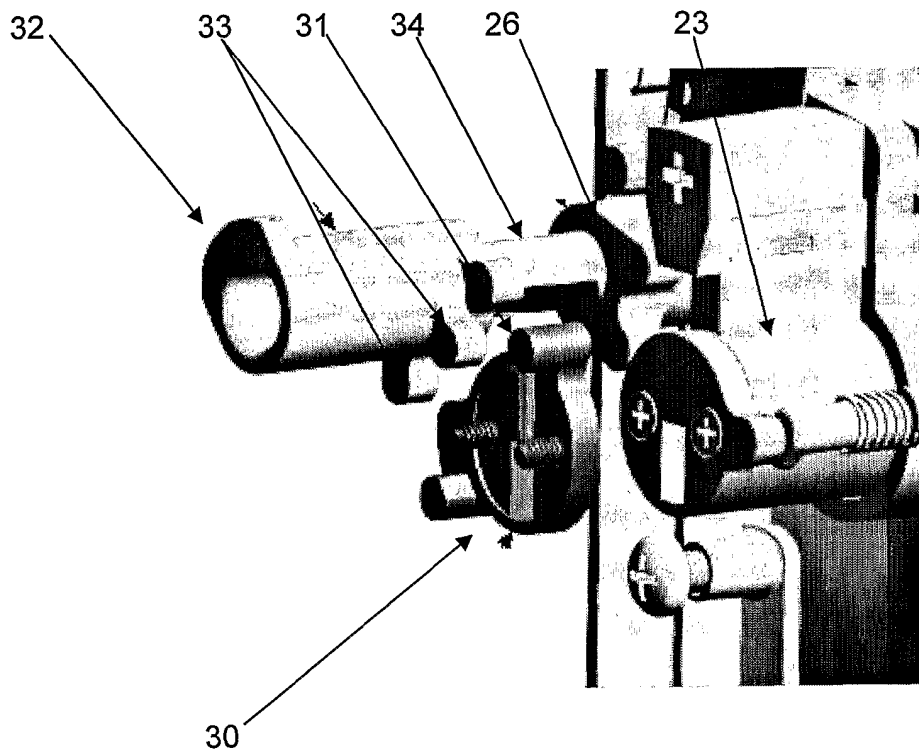

FIG 6

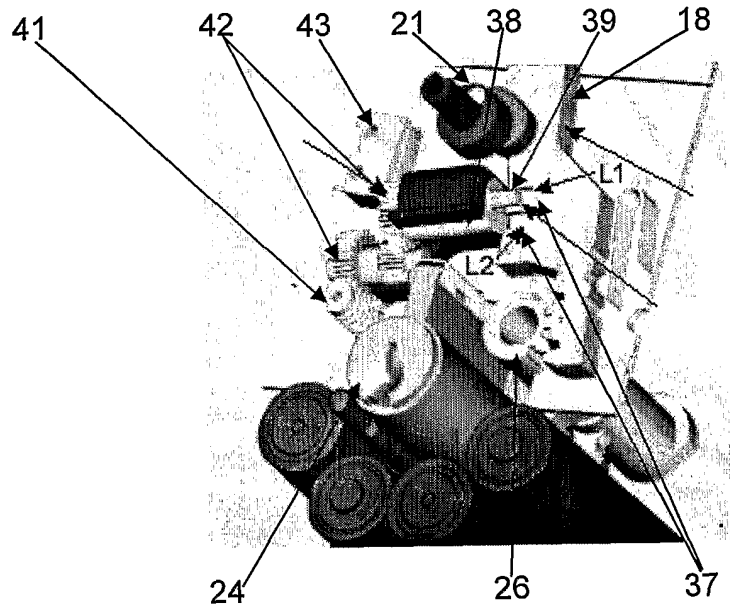

FIG 7

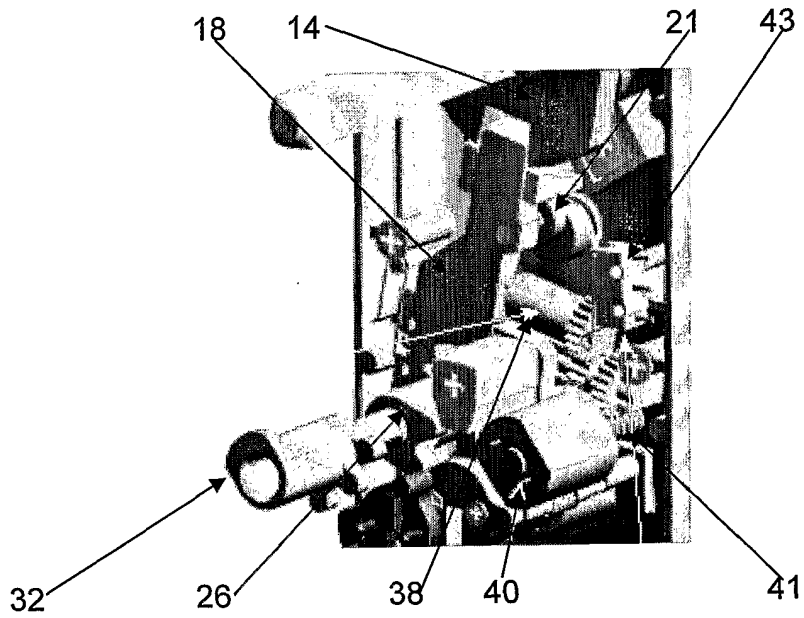

FIG 8

INTERNATIONAL SEARCH REPORT

International application No.

PCT/AU2004/000107

A. CLASSIFICATION OF SUBJECT MATTER		
Int. Cl. ⁷ : E05B 63/08, 65/06, 59/00, 13/00		
According to International Patent Classification (IPC) or to both national classification and IPC		
B. FIELDS SEARCHED		
Minimum documentation searched (classification system followed by classification symbols)		
Documentation searched other than minimum documentation to the extent that such documents are included in the fields searched		
Electronic data base consulted during the international search (name of data base and, where practicable, search terms used) DWPI & Keywords: multi, plural, three, tri, mode, way, configure, deadlock, private, privacy, passage, entrance, hub, plate, disc, disc, e05b/ic, and similar terms.		
C. DOCUMENTS CONSIDERED TO BE RELEVANT		
Category*	Citation of document, with indication, where appropriate, of the relevant passages	Relevant to claim No.
X	US 5651568 A (FORTUNE et al.) 29 July 1997 see entire document	1-31
X	US 5123682 A (ROBIDA et al.) 23 June 1992 see entire document	1-31
X	US 4594864 A (HART) 17 June 1986 see entire document	1-31
A	US 4979383 A (TULLY) 25 December 1990	
<input type="checkbox"/> Further documents are listed in the continuation of Box C <input checked="" type="checkbox"/> See patent family annex		
* Special categories of cited documents: "A" document defining the general state of the art which is not considered to be of particular relevance "E" earlier application or patent but published on or after the international filing date "L" document which may throw doubts on priority claim(s) or which is cited to establish the publication date of another citation or other special reason (as specified) "O" document referring to an oral disclosure, use, exhibition or other means "P" document published prior to the international filing date but later than the priority date claimed "T" later document published after the international filing date or priority date and not in conflict with the application but cited to understand the principle or theory underlying the invention "X" document of particular relevance; the claimed invention cannot be considered novel or cannot be considered to involve an inventive step when the document is taken alone "Y" document of particular relevance; the claimed invention cannot be considered to involve an inventive step when the document is combined with one or more other such documents, such combination being obvious to a person skilled in the art "&" document member of the same patent family		
Date of the actual completion of the international search 15 April 2004		Date of mailing of the international search report 20 APR 2004
Name and mailing address of the ISA/AU AUSTRALIAN PATENT OFFICE PO BOX 200, WODEN ACT 2606, AUSTRALIA E-mail address: pct@ipaaustralia.gov.au Facsimile No. (02) 6285 3929		Authorized officer Geoff Sadlier Telephone No : (02) 6283 2114

Box No. II Observations where certain claims were found unsearchable (Continuation of item 2 of first sheet)

This international search report has not been established in respect of certain claims under Article 17(2)(a) for the following reasons:

1. Claims Nos.:
because they relate to subject matter not required to be searched by this Authority, namely:

2. Claims Nos.:
because they relate to parts of the international application that do not comply with the prescribed requirements to such an extent that no meaningful international search can be carried out, specifically:

3. Claims Nos.:
because they are dependent claims and are not drafted in accordance with the second and third sentences of Rule 6.4(a)

Box No. III Observations where unity of invention is lacking (Continuation of item 3 of first sheet)

This International Searching Authority found multiple inventions in this international application, as follows:

See supplemental sheet

1. As all required additional search fees were timely paid by the applicant, this international search report covers all searchable claims.
2. As all searchable claims could be searched without effort justifying an additional fee, this Authority did not invite payment of any additional fee.
3. As only some of the required additional search fees were timely paid by the applicant, this international search report covers only those claims for which fees were paid, specifically claims Nos.:

4. No required additional search fees were timely paid by the applicant. Consequently, this international search report is restricted to the invention first mentioned in the claims; it is covered by claims Nos.: 1-31

Remark on Protest

- The additional search fees were accompanied by the applicant's protest.
- No protest accompanied the payment of additional search fees.

Supplemental Box

(To be used when the space in any of Boxes I to VIII is not sufficient)

Continuation of Box No: III

The international application does not comply with the requirements of unity of invention because it does not relate to one invention or to a group of inventions so linked as to form a single general inventive concept. In coming to this conclusion the International Searching Authority has found that there are different inventions as follows:

Claims 1-31 are directed to a door lock having internal and external handles and a mechanism that allows for a passage mode, privacy mode and deadlock mode. It is considered that the provision of an outer hub and an internal hub, which are inside the lock body, comprises a first "special technical feature".

Claim 32 is also directed to a lock having a mechanism that allows for a passage mode, privacy mode and deadlock mode. It is considered that a remote control means to allow at least some of the modes to be operated by remote control comprises a second special technical feature.

The feature common to all of the claims is the general subject matter of a lock having a mechanism that allows for a passage mode, privacy mode and deadlock mode. However this common feature is generic in the art. Consequently the common feature does not constitute "a special technical feature" within the meaning of PCT Rule 13.2, second sentence, since it makes no contribution over the prior art. Since there exists no other common feature which can be considered as a special technical feature within the meaning of PCT Rule 13.2, second sentence, no technical relationship within the meaning of PCT Rule 13 between the different inventions can be seen. Consequently the claims do not satisfy the requirement of unity of invention a posteriori.

INTERNATIONAL SEARCH REPORT

Information on patent family members

International application No.

PCT/AU2004/000107

This Annex lists the known "A" publication level patent family members relating to the patent documents cited in the above-mentioned international search report. The Australian Patent Office is in no way liable for these particulars which are merely given for the purpose of information.

Patent Document Cited in Search Report		Patent Family Member					
US	5651568	AU	27286/95	AU	48888/93	CN	1092494
		GB	2271380	GB	2291112	SG	50654
		SG	52685	US	5484177		
US	5123682	AU	85702/91	CA	2053166	JP	4315682
		MX	9101561	ZA	9108095		
US	4594864	AU	33938/84	AU	33939/84	BR	8407107
		BR	8407214	CA	1237157	CA	1254924
		EP	0136885	EP	0136891	ES	8603011
		ES	8603012	HK	12791	HK	26790
		IL	72942	IL	72948	PH	21411
		PH	23967	US	4945737	WO	8501542
		WO	8503101				
US	4979383	AU	57133/90	CA	2018984	EP	0419194

Due to data integration issues this family listing may not include 10 digit Australian applications filed since May 2001.

END OF ANNEX