



(22) Date de dépôt/Filing Date: 2014/08/12

(41) Mise à la disp. pub./Open to Public Insp.: 2015/04/16

(45) Date de délivrance/Issue Date: 2017/04/04

(30) Priorité/Priority: 2013/10/16 (US14/055,560)

(51) Cl.Int./Int.Cl. *B64C 21/02* (2006.01),
F15D 1/10 (2006.01), *F15D 1/12* (2006.01)

(72) Inventeur/Inventor:
GRIFFIN, STEVEN F., US

(73) Propriétaire/Owner:
THE BOEING COMPANY, US

(74) Agent: SMART & BIGGAR

(54) Titre : AMORTISSEUR DE JET SYNTHETIQUE

(54) Title: SYNTHETIC JET MUFFLER

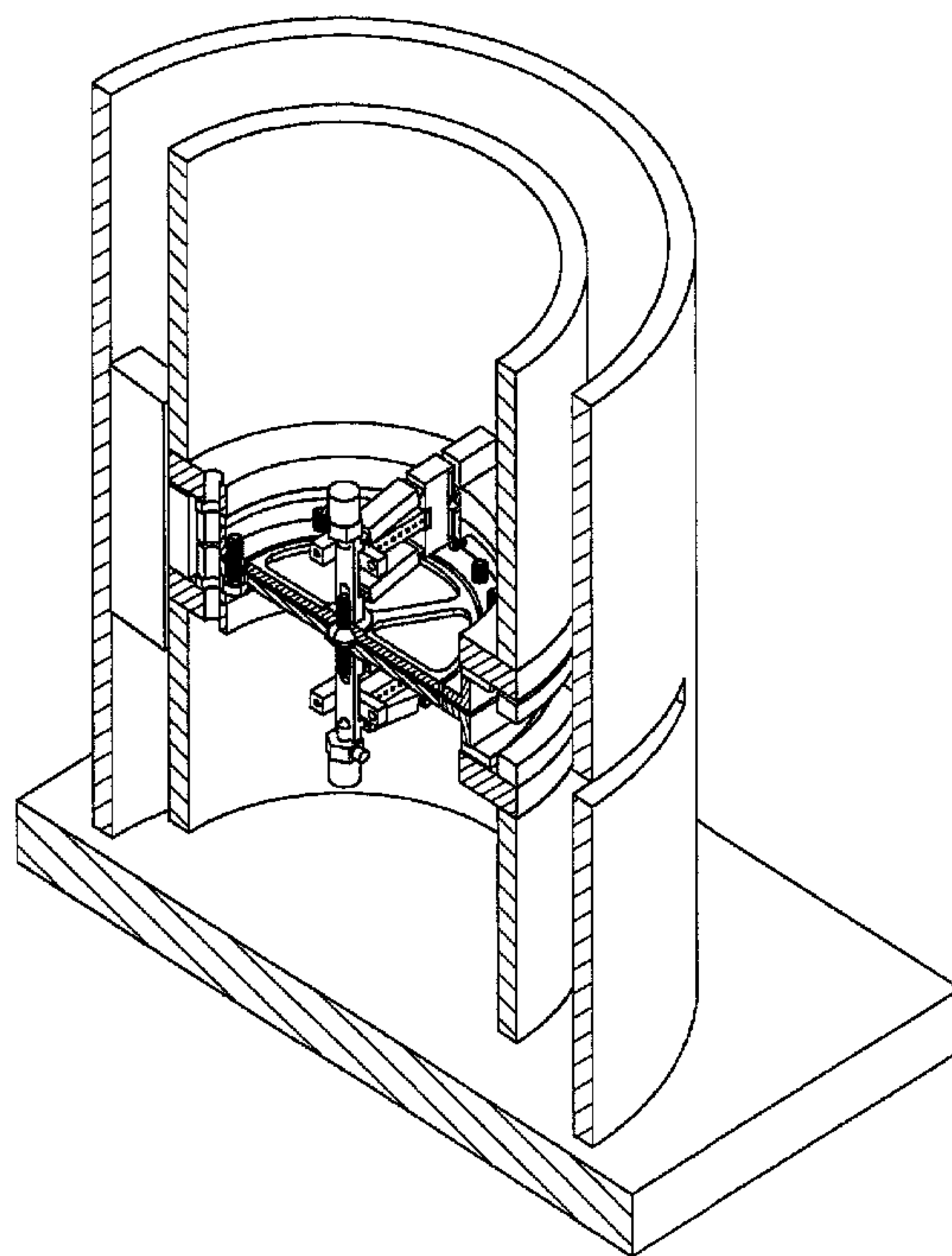

(57) Abrégé/Abstract:

A synthetic jet muffler includes an exit end, a propagation path for conducting a first sound wave emitted by a synthetic jet generator to the exit end, and a shroud for conducting a second sound wave emitted from the synthetic jet generator in a direction opposite to the first sound wave to the exit end, wherein the shroud is disposed so that the first and second sound waves travel different distances to effect noise cancellation at the exit end.

ABSTRACT OF THE DISCLOSURE

A synthetic jet muffler includes an exit end, a propagation path for conducting a first sound wave emitted by a synthetic jet generator to the exit end, and a shroud for conducting a
5 second sound wave emitted from the synthetic jet generator in a direction opposite to the first sound wave to the exit end, wherein the shroud is disposed so that the first and second sound waves travel different distances to effect noise cancellation at the exit end.

SYNTHETIC JET MUFFLER

BACKGROUND

1. Field

5 The exemplary embodiments generally relate to synthetic jets and, more particularly, to canceling sound emanating from synthetic jet generators.

2. Brief Description of Related Developments

10 A synthetic jet generator typically includes a volume with one or more apertures. The volume is generally pumped at a single frequency in the audible range. to force air in and out of the one or more apertures to form a synthetic jet. While producing an effective synthetic jet, the reciprocating, single frequency action of the pumping mechanism of the synthetic jet generator generally produces high sound levels at the drive frequency. High sound levels may also be produced by the resulting synthetic jet, however, in practical applications, the synthetic jet produces noise outside of a supporting structure, while the pumping mechanism produces noise inside the structure.

20 Traditional methods of increasing sound attenuation typically include passive treatments, for example, adding mass or dampening materials. However, adding mass may generally decrease performance, in particular for in flight applications. Furthermore, because acoustic propagation paths are difficult to analyze, passive treatments are generally applied conservatively, resulting in adding more mass than required.

It would be advantageous to provide a device for cancelling noise caused by the pumping action of a synthetic jet generator without adding excessive treatments.

25 The invention can involve a synthetic jet muffler that may include an exit end; a propagation path for conducting a first sound wave emitted by a synthetic jet generator to the exit end; and a shroud for conducting a second sound wave emitted from the synthetic jet generator in a direction opposite to the first sound wave to the exit end, wherein the shroud is disposed so that the first and second sound waves travel different distances to effect noise cancellation at the exit end. The difference in distances travelled by the first and second sound waves may effect a phase difference between the first and second sound waves that can

30

substantially cancel the first and second sound waves at the exit end of the synthetic jet muffler. The synthetic jet generator may operate at a substantially fixed frequency. The difference in distances travelled by the first and second sound waves may correspond to $n*\lambda/2$ where n is an odd integer and λ is a wavelength of the substantially fixed frequency. The synthetic jet generator may include synchronized opposing synthetic jet actuators. The the synchronized opposing synthetic jet actuators may include opposing pistons. The shroud may be positioned to surround the synthetic jet and comprises at least one aperture for conducting a flow generated by the synthetic jet.

The invention can involve an apparatus that may include a synthetic jet comprising two or more actuators producing sound waves in different directions; and a shroud surrounding the synthetic jet, the shroud having an open end and a waveguide structure having propagation paths of different lengths for the sound waves to effect noise cancellation at the open end. The difference in lengths of the propagation paths may effect a phase difference between the sound waves substantially cancelling the sound waves at the open end. The synthetic jet actuators may operate at a substantially fixed frequency. The difference in distances of the propagation paths may correspond to $n*\lambda/2$ where n is an odd integer and λ is a wavelength of the substantially fixed frequency. The two or more actuators may operate synchronously in opposing directions. The two or more actuators may include opposing pistons. The shroud may include at least one aperture for conducting a flow generated by the synthetic jet.

The invention can involve a method of reducing noise produced by a synthetic jet that may include operating the synthetic jet at a substantially fixed frequency to pump a fluid; conducting sound waves produced in different directions by the synthetic jet through waveguides having different lengths relative to the substantially fixed frequency for effecting noise cancellation at a common exit plane of the waveguides. The different waveguide lengths may effect a phase difference between the sound waves substantially cancelling the sound waves at the common exit plane. A difference in the waveguide lengths may correspond to $n*\lambda/2$ where n is an odd integer and λ is a wavelength of the substantially fixed frequency.

The synthetic jet may include two or more actuators operating synchronously in opposing directions.

30

BRIEF DESCRIPTION OF THE DRAWINGS

Figure 1 shows a schematic illustration of a cross section of an exemplary synthetic jet generator in accordance with aspects of the disclosed embodiment;

Figure 1A shows exemplary synthetic jets integrated onto or with a suitable fluid boundary surface in accordance with aspects of the disclosed embodiment;

Figure 2 shows a diagram of an exemplary synthetic jet muffler in accordance with aspects of the disclosed embodiment;

Figures 3A and 3B show a cross sectional and an isometric view of an exemplary synthetic jet muffler in accordance with aspects of the disclosed embodiment;

Figure 4 shows an exemplary schematic of sound pressure along propagation paths of a synthetic jet muffler in accordance with aspects of the disclosed embodiment;

Figure 5 shows an exemplary model of a synthetic jet muffler in accordance with aspects of the disclosed embodiment; and

Figure 6 shows a schematic diagram of an exemplary aspect where one or more synthetic jets with mufflers are used in combination with an airfoil in accordance with aspects of the disclosed embodiment.

DETAILED DESCRIPTION

Figure 1 shows an exemplary jet or jet generator **100** for use with the disclosed embodiment. Unless otherwise noted, the term jet may be used alternately to refer to the jet generator or the jet flow effected by the jet generator. The exemplary jet generator **100** may operate by moving a fluid back and forth through an opening or aperture. A synthetic jet flow may be produced by the cyclic suction and expulsion of the fluid from a cavity through the opening by a piston or diaphragm. The exemplary jet generator **100** may include actuators **105**, **110**, which may include respectively coupled pistons **115** and **120**, at least one cavity defining a volume **125**, and at least one aperture **130**. In the exemplary embodiment illustrated in Figure 1, the jet **100** is shown for clarity and descriptive purposes without surrounding structures or surfaces to which the jet may be mounted or interfaced. As may be realized, however, the synthetic jet (or any number thereof) may be integrated as desired on to or with suitable fluid boundary surfaces as shown, for example, in Figure 1A.

The actuators **105**, **110** may comprise one or more piezoelectric, electro-strictive, or electromagnet elements. The pistons **115**, **120** may each comprise a rigid body or may be flexible and periodically bowed, bent, or otherwise deformed to change the volume **125** of the cavity. The pumping action of pistons **115** and **120** generates a synthetic jet **135** by cyclically pulling in and expelling a fluid, for example, air, through the aperture **130**. Arrows **140**, **145** show the pumping direction of pistons **115** and **120**, respectively. The pistons **115**, **120** are each moving away and toward the volume in a synchronized fashion and thus are effective at radiating sound external to the synthetic jet generator **100**. In this exemplary embodiment, the jet is provided by the pistons **115**, **120** which may be considered to represent a sound point source formed by the synchronous pumping action. It should be understood that while the cyclic suction and expulsion are described herein as being achieved using actuators and pistons, any suitable mechanism using any suitable technique may be used to effect the actions of the generator for generating a synthetic jet.

In at least one aspect of the disclosed embodiment, a waveguide structure that introduces a phase difference of approximately **180** degrees in the sound waves radiating from the jet (such as from each of the pistons **115**, **120**) may be used to substantially cancel the noise from the pistons. The jet may be operated at a substantially fixed frequency, and may use a structure with dimensions determined from the operating frequency to effect the noise cancellation. Figure **2** depicts a cross section of an exemplary synthetic jet muffler **200** according to the aspects of the disclosed embodiment.

The synthetic jet muffler **200** may include an exit end **210** and at least two propagation paths for conducting sound waves generated by a synthetic jet generator **225**. The synthetic jet muffler may also include at least one aperture **260**, corresponding to one or more apertures **265** of the synthetic jet generator **225**. A first propagation path **215** may be provided for conducting a first sound wave **220**, emitted by the synthetic jet **225** to the exit end **210**. The first sound wave **220** may be generated by the action of a first piston **230** of the synthetic jet **225** driven by an actuator **235**. The synthetic jet muffler may also include a shroud **240** for effecting a second propagation path **270** for conducting a second sound wave **245** emitted by the synthetic jet generator **225** in a direction opposite to the first sound wave **220**. The second sound wave **245** may be generated by the action of a second piston **250** of the synthetic jet generator **225** driven by an actuator **255** and the shroud **240** may be arranged to conduct the second sound wave **245** to the exit end **210**.

In at least one exemplary aspect, the shroud **240** may include at least two structures **275, 280** forming a generally annular configuration. The structures may be arranged as a first cylinder **280** surrounded by a second cylinder **275**, both having an opening in a common plane **285** forming the exit end **210** of the synthetic jet muffler **200**. The first cylinder **280** may enclose the synthetic jet generator **225** and have an additional open end **288**, where the open ends of the first cylinder effect opposing propagation paths for the first and second sound waves **220, 245**. The first cylinder **280** may also include an opening **290** to allow fluid to flow through aperture **265** to produce the synthetic jet. The second cylinder **275** may include a closed end **292** utilized to provide the second propagation path **270** to the exit end **210** for the second sound wave **245**. The second cylinder **275** may include the aperture **260**, corresponding to one or more apertures **265** of the synthetic jet generator **225**. While the structures **275, 280** are described as cylinders and as a first cylinder surrounded by a second cylinder, it should be understood that the disclosed embodiment may include any other structures arranged in any other configurations so long as the noise cancelling effects via phase shift and direction matching of sound waves from the synthetic jet are achieved. Figures **3A** and **3B** show a cross sectional and an isometric view, respectively, of aspects of an exemplary synthetic jet muffler.

The shroud **240** may be further arranged so that the distances traveled by the first and second sound waves **220, 245** are different and operate to effect noise cancellation at the exit end **210**. In at least one aspect, because the actuators and pistons operate at a substantially fixed frequency, the shroud may provide a difference in distances travelled by the first and second sound waves **220, 245** that effects a phase difference between the first and second sound waves **220, 245** substantially cancelling the first and second sound waves at the exit end **210** of the synthetic jet muffler. According to another aspect, the shroud may be arranged to provide a difference in distances travelled by the first and second sound waves that may correspond to $n*\lambda/2$ where n is an odd integer and λ is a wavelength of the substantially fixed frequency.

Figure **4** shows an exemplary schematic diagram **400** of sound pressure along the propagation paths of the synthetic jet muffler **200**. As a result of the difference in propagation paths, the sound pressure **410** generated by the first piston **230** is substantially out of phase with the sound pressure **415** generated by the second piston **250**. When the sound pressure

waves **410, 415** reach the exit **210** of the synthetic jet muffler, sound produced by the sound pressure waves is substantially cancelled.

A model **500** of the synthetic jet muffler **200** using finite element analysis is shown in Figure **5**. The model **400** shows a cross section of the results of modeling the propagation path **270** of the second sound wave **255**, and shows the pressure distribution of the acoustic mode resulting from the geometry of the synthetic jet muffler at or near a drive frequency of the exemplary synthetic jet generator **225**.

The aspects of the disclosed embodiment may provide effective noise cancellation over a range of frequencies, however, as the frequency of operation of the synthetic jet generator increases, diffraction effects of the sound waves may impact the amount of cancellation achieved. At relatively low frequencies, the pistons operate as uniform radiators and diffraction effects of the sound waves may be negligible. However, at higher frequencies effective noise cancellation may require matching the directivity of sound sources resulting from sound waves **220, 245** as they pass the exit opening **210**, in addition to providing a phase difference between the first and second sound waves **220**. A mismatch of directivity at higher frequencies may cause incomplete cancellation of the sound field at off-axis locations, while cancellation may still be effective at the exit end of the synthetic jet muffler.

Figure **6** shows a schematic diagram of an exemplary aspect where one or more synthetic jets **600** with mufflers **605** according to the disclosed embodiment may be used in combination with an airfoil **610** to achieve active flow control. For example, the one or more synthetic jets **600** may be used to control flow separation by adding or subtracting energy from a fluid boundary layer **615**. In particular, the one or more synthetic jets **600** may be used to decrease drag by suppressing flow separation or shedding in order to prevent leading edge stall at high angles of attack. An exemplary airfoil with synthetic jets is shown in US Patent No.: **5,938,404**, incorporated by reference in its entirety. As mentioned above, the synthetic jet **600** may produce high sound levels inside the airfoil due to the reciprocating, single frequency action of the pumping mechanism and the addition of the muffler **605** may at least operate to cancel this noise. It should be understood that the locations, arrangement and number of synthetic jets **600** and mufflers **605** in Figure **6** are exemplary only and that any suitable configuration and quantity may be utilized. For example, the synthetic jets **600** and mufflers **605** may be mounted on a surface or embedded within the airfoil, and may be have any orientation so long as the noise is attenuated or cancelled.

In accordance with one or more aspects of the disclosed embodiment, a synthetic jet muffler includes an exit end, a propagation path for conducting a first sound wave emitted by a synthetic jet generator to the exit end, and a shroud for conducting a second sound wave emitted from the synthetic jet generator in a direction opposite to the first sound wave to the exit end, wherein the shroud is disposed so that the first and second sound waves travel different distances to effect noise cancellation at the exit end.

In accordance with one or more aspects of the disclosed embodiment, the difference in distances travelled by the first and second sound waves effect a phase difference between the first and second sound waves substantially cancelling the first and second sound waves at the exit end of the synthetic jet muffler.

In accordance with one or more aspects of the disclosed embodiment, the synthetic jet generator operates at a substantially fixed frequency.

In accordance with one or more aspects of the disclosed embodiment, the difference in distances travelled by the first and second sound waves corresponds to $n*\lambda/2$ where n is an odd integer and λ is a wavelength of the substantially fixed frequency.

In accordance with one or more aspects of the disclosed embodiment, the synthetic jet generator comprises synchronized opposing synthetic jet actuators.

In accordance with one or more aspects of the disclosed embodiment, the synchronized opposing synthetic jet actuators comprise opposing pistons.

In accordance with one or more aspects of the disclosed embodiment, the shroud is positioned to surround the synthetic jet and comprises at least one aperture for conducting a flow generated by the synthetic jet.

In accordance with one or more aspects of the disclosed embodiment, an apparatus includes a synthetic jet having two or more actuators producing sound waves in different directions, and a shroud surrounding the synthetic jet, the shroud having an open end and a waveguide structure having propagation paths of different lengths for the sound waves to effect noise cancellation at the open end.

In accordance with one or more aspects of the disclosed embodiment, the difference in lengths of the propagation paths effect a phase difference between the sound waves substantially cancelling the sound waves at the open end.

In accordance with one or more aspects of the disclosed embodiment, the synthetic jet actuators operate at a substantially fixed frequency.

5 In accordance with one or more aspects of the disclosed embodiment, the difference in distances of the propagation paths corresponds to $n\lambda/2$ where n is an odd integer and λ is a wavelength of the substantially fixed frequency.

In accordance with one or more aspects of the disclosed embodiment, the two or more actuators operate synchronously in opposing directions.

In accordance with one or more aspects of the disclosed embodiment, the two or more actuators comprise opposing pistons.

10 In accordance with one or more aspects of the disclosed embodiment, the shroud comprises at least one aperture for conducting a flow generated by the synthetic jet.

15 In accordance with one or more aspects of the disclosed embodiment, a method of reducing noise produced by a synthetic jet includes operating the synthetic jet at a substantially fixed frequency to pump a fluid, and conducting sound waves produced in different directions by the synthetic jet through waveguides having different lengths relative to the substantially fixed frequency for effecting noise cancellation at a common exit plane of the waveguides.

In accordance with one or more aspects of the disclosed embodiment, the different waveguide lengths effect a phase difference between the sound waves substantially cancelling the sound waves at the common exit plane.

20 In accordance with one or more aspects of the disclosed embodiment, a difference in the waveguide lengths corresponds to $n\lambda/2$ where n is an odd integer and λ is a wavelength of the substantially fixed frequency.

In accordance with one or more aspects of the disclosed embodiment, the synthetic jet comprises two or more actuators operating synchronously in opposing directions.

25 It should be understood that the foregoing description is only illustrative of the aspects of the disclosed embodiment. Various alternatives and modifications can be devised by those skilled in the art without departing from the aspects of the disclosed embodiment. Accordingly, the aspects of the disclosed embodiment are intended to embrace all such alternatives, modifications and variances that fall within the scope of the appended claims. Further, the
30 mere fact that different features are recited in mutually different dependent or

independent claims does not indicate that a combination of these features cannot be advantageously used, such a combination remaining within the scope of the aspects of the invention.

THE EMBODIMENTS OF THE INVENTION IN WHICH AN EXCLUSIVE PROPERTY OR PRIVILEGE IS CLAIMED ARE DEFINED AS FOLLOWS:

- 5 **1.** A synthetic jet muffler comprising:
- an exit end;
- a propagation path for conducting a first sound wave emitted by a synthetic jet
10 generator to the exit end; and
- a shroud for conducting a second sound wave emitted from the synthetic jet
 generator in a direction opposite to the first sound wave to the exit end, wherein
 the shroud is disposed so that the first and second sound waves travel different
15 distances to effect noise cancellation at the exit end.
- 2.** The synthetic jet muffler of claim **1**, wherein the difference in distances travelled by the
 first and second sound waves effect a phase difference between the first and second
 sound waves substantially cancelling the first and second sound waves at the exit end
20 of the synthetic jet muffler.
- 3.** The synthetic jet muffler of claim **1**, wherein the synthetic jet generator operates at a
 substantially fixed frequency.
- 25 **4.** The synthetic jet muffler of claim **3**, wherein the difference in distances travelled by the
 first and second sound waves corresponds to $n \cdot \lambda / 2$ where n is an odd integer and λ is a
 wavelength of the substantially fixed frequency.
- 5.** The synthetic jet muffler of claim **1**, wherein the synthetic jet generator comprises
30 synchronized opposing synthetic jet actuators.

6. The synthetic jet muffler of claim 5, wherein the synchronized opposing synthetic jet actuators comprise opposing pistons.
7. The synthetic jet muffler of claim 1, wherein the shroud is positioned to surround the synthetic jet and comprises at least one aperture for conducting a flow generated by the synthetic jet.
8. An apparatus comprising:
- 10 a synthetic jet comprising two or more actuators producing sound waves in different directions; and
- 15 a shroud surrounding the synthetic jet, the shroud having an open end and a waveguide structure having propagation paths of different lengths for the sound waves to effect noise cancellation at the open end.
9. The apparatus claim 8, wherein the difference in lengths of the propagation paths effect a phase difference between the sound waves substantially cancelling the sound waves at the open end.
- 20 10. The apparatus of claim 8, wherein the synthetic jet actuators operate at a substantially fixed frequency.
11. The apparatus of claim 10, wherein the difference in distances of the propagation paths corresponds to $n \cdot \lambda / 2$ where n is an odd integer and λ is a wavelength of the substantially fixed frequency.
- 25 12. The apparatus of claim 8, wherein the two or more actuators operate synchronously in opposing directions.
- 30 13. The apparatus of claim 12, wherein the two or more actuators comprise opposing pistons.

14. The apparatus of claim 8, wherein the shroud comprises at least one aperture for conducting a flow generated by the synthetic jet.
15. A method of reducing noise produced by a synthetic jet comprising:
5
operating the synthetic jet at a substantially fixed frequency to pump a fluid;
conducting sound waves produced in different directions by the synthetic jet through waveguides having different lengths relative to the substantially fixed
10 frequency for effecting noise cancellation at a common exit plane of the waveguides.
16. The method of claim 15, wherein the different waveguide lengths effect a phase difference between the sound waves substantially cancelling the sound waves at the
15 common exit plane.
17. The method of claim 15, wherein a difference in the waveguide lengths corresponds to $n*\lambda/2$ where n is an odd integer and λ is a wavelength of the substantially fixed frequency.
20
18. The method of claim 15, wherein the synthetic jet comprises two or more actuators operating synchronously in opposing directions.

1/7

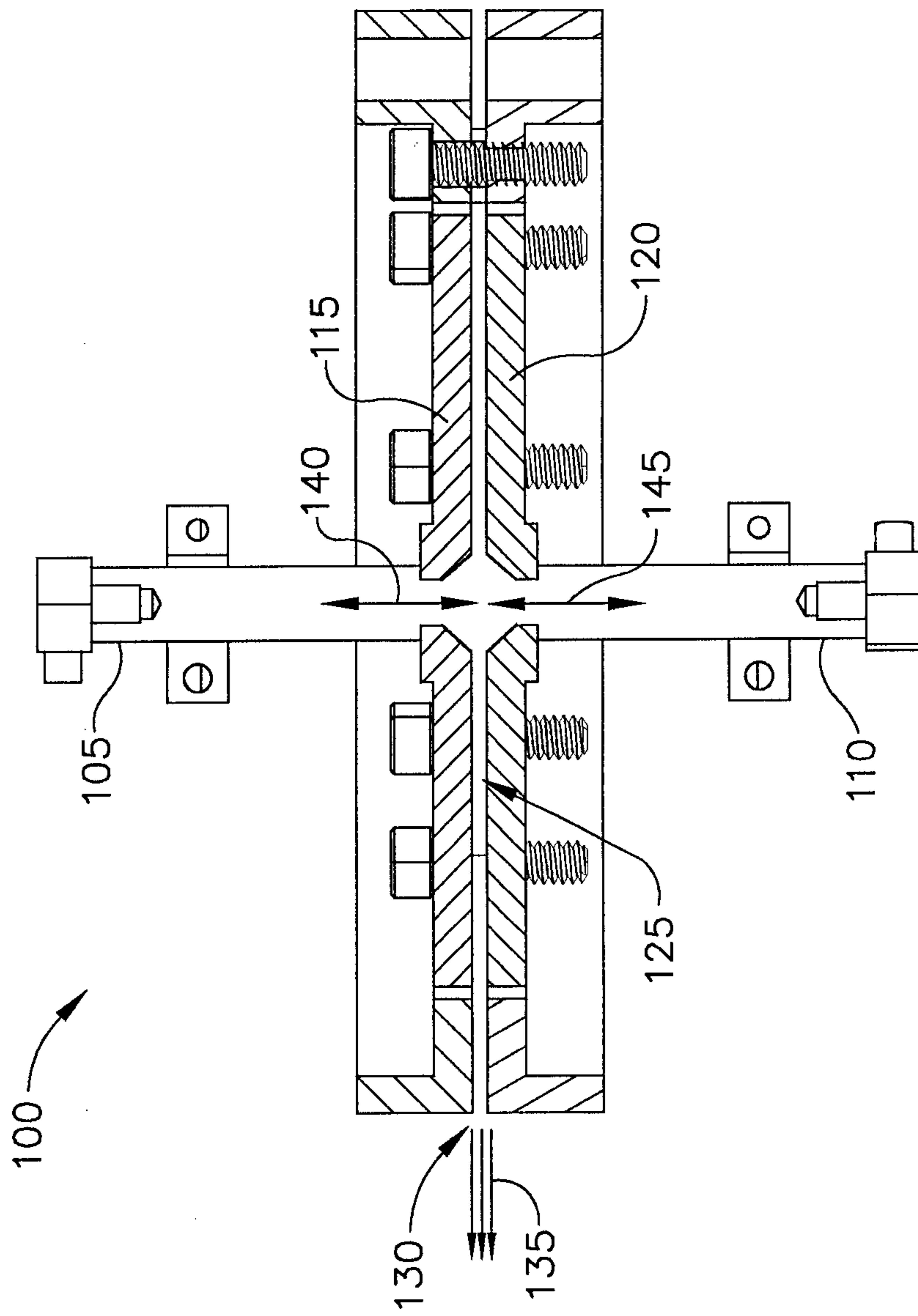

FIG. 1

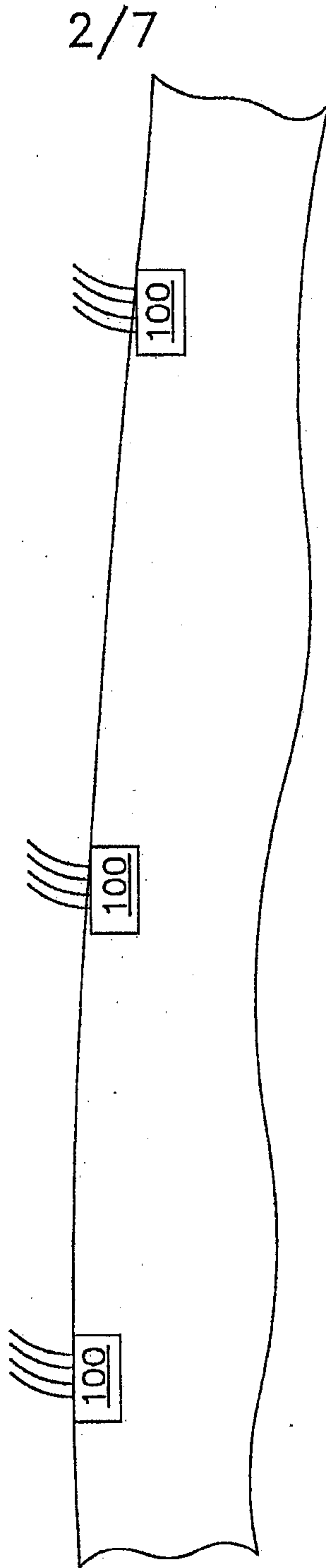

FIG. 1A

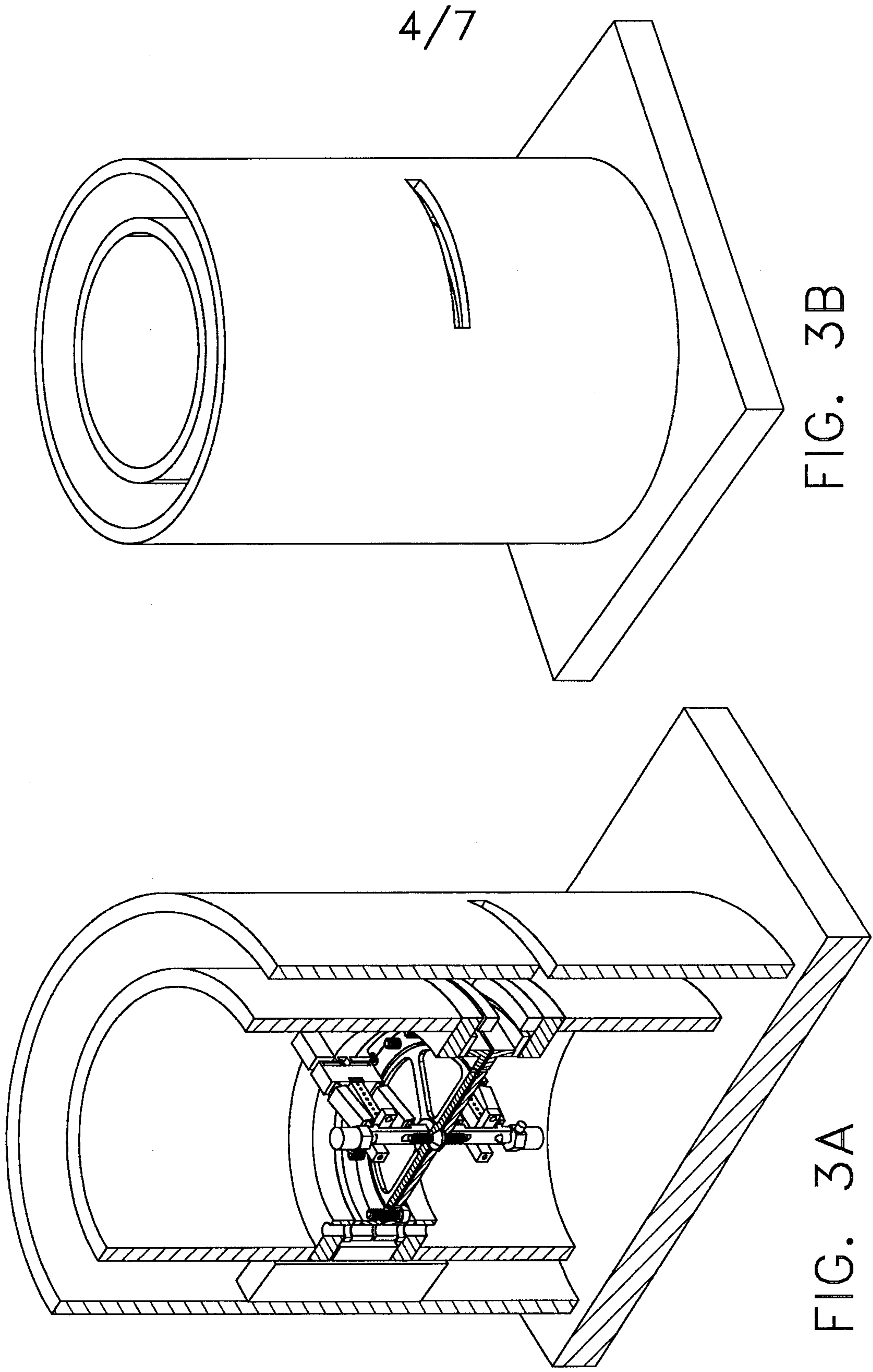

FIG. 3B

FIG. 3A

5/7

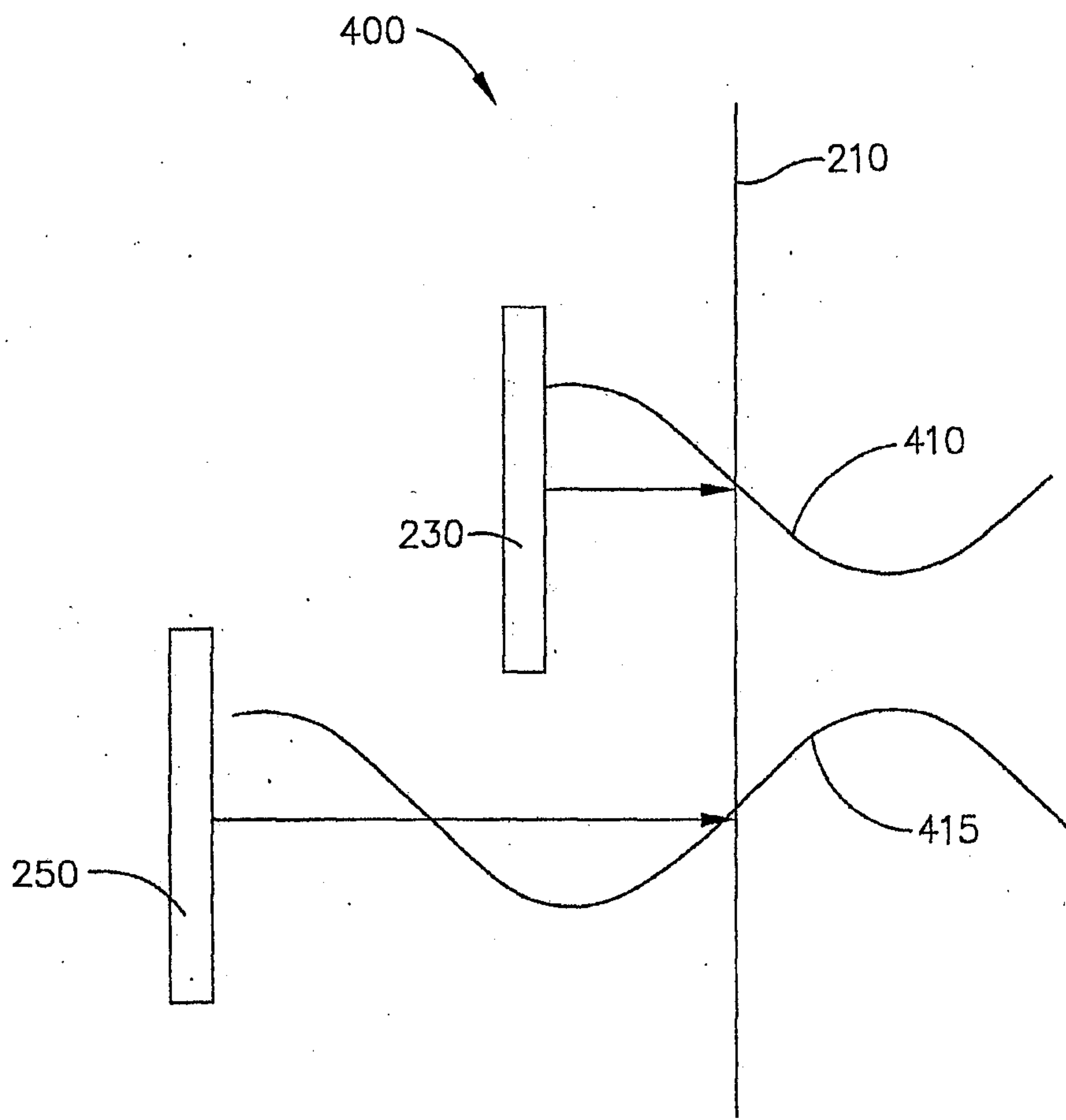

FIG. 4

6/7

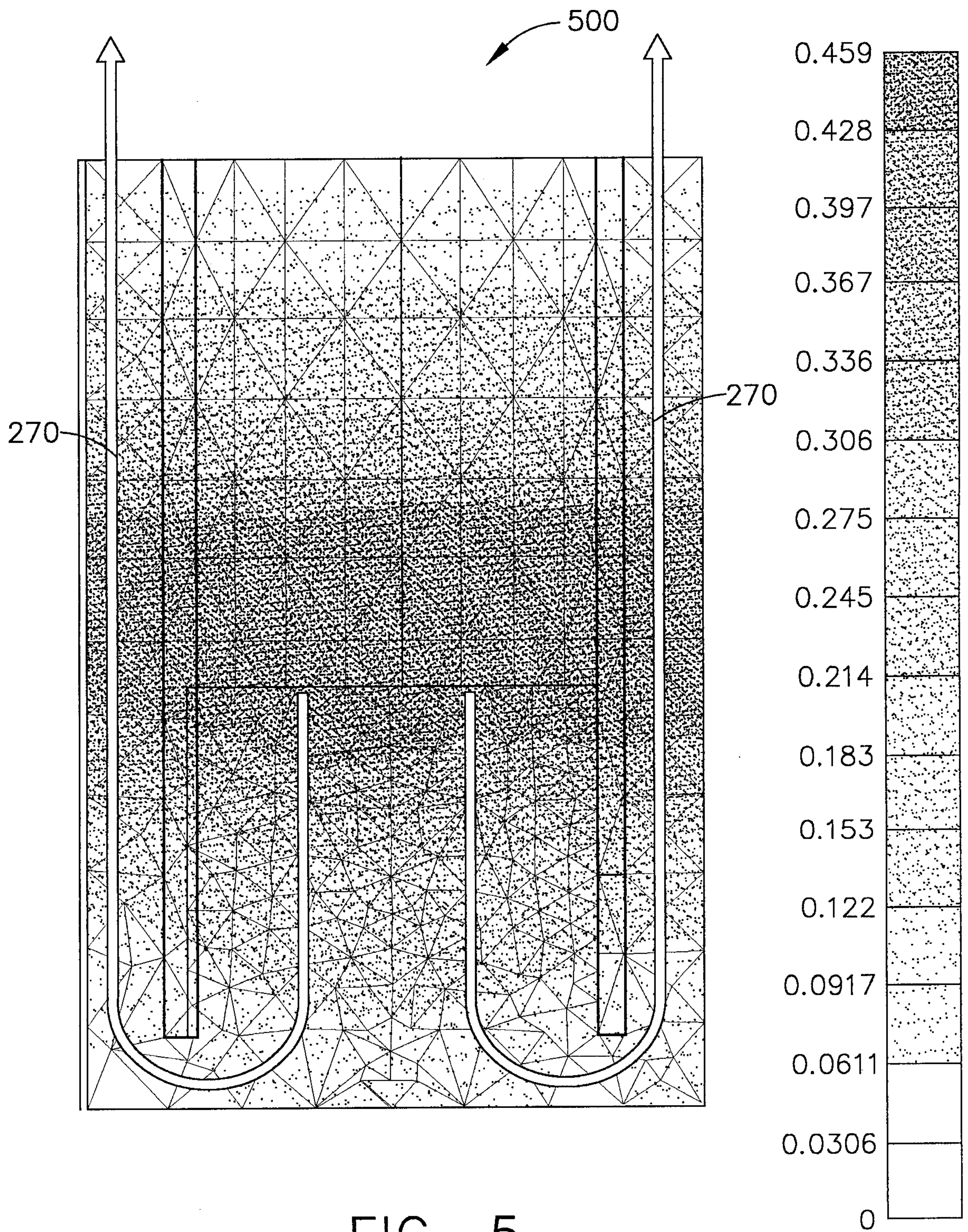

FIG. 5

7/7

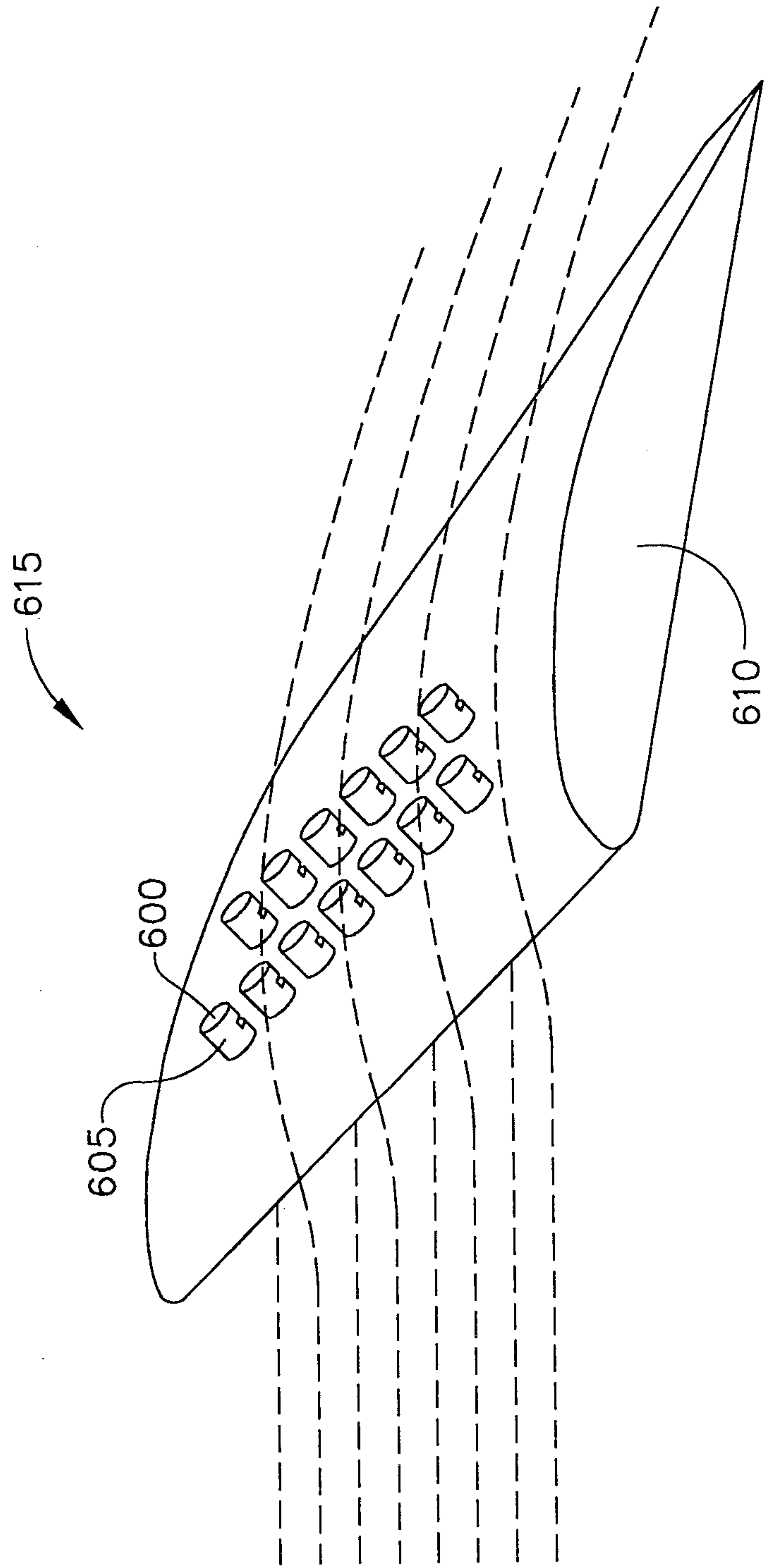

FIG. 6

