

(19) World Intellectual Property Organization
International Bureau



(43) International Publication Date
14 May 2009 (14.05.2009)

PCT

(10) International Publication Number
WO 2009/059720 A1

(51) International Patent Classification:

B60T 1/06 (2006.01) F16D 55/00 (2006.01)
F16D 55/40 (2006.01) B60K 17/04 (2006.01)
F16D 65/14 (2006.01)

Robert [DE/DE]; Langweid 2, 87647 Oberthingau (DE).
DOBLER, Johann [DE/DE]; Hauptstr. 60, 87764 Legau (DE).

(21) International Application Number:

PCT/EP2008/009157

(74) Agent: MORRALL, Roger; Agco Limited, Abbey Park, Stoneleigh, Kenilworth, CV8 2TQ (GB).

(22) International Filing Date: 30 October 2008 (30.10.2008)

(81) Designated States (unless otherwise indicated, for every kind of national protection available): AE, AG, AL, AM, AO, AT, AU, AZ, BA, BB, BG, BH, BR, BW, BY, BZ, CA, CH, CN, CO, CR, CU, CZ, DE, DK, DM, DO, DZ, EC, EE, EG, ES, FI, GB, GD, GE, GH, GM, GT, HN, HR, HU, ID, IL, IN, IS, JP, KE, KG, KM, KN, KP, KR, KZ, LA, LC, LK, LR, LS, LT, LU, LY, MA, MD, ME, MG, MK, MN, MW, MX, MY, MZ, NA, NG, NI, NO, NZ, OM, PG, PH, PL, PT, RO, RS, RU, SC, SD, SE, SG, SK, SL, SM, ST, SV, SY, TJ, TM, TN, TR, TT, TZ, UA, UG, US, UZ, VC, VN, ZA, ZM, ZW.

(25) Filing Language: English

(26) Publication Language: English

(30) Priority Data:

10 2007 053 325.1
8 November 2007 (08.11.2007) DE
10 2007 053 267.0
8 November 2007 (08.11.2007) DE

(84) Designated States (unless otherwise indicated, for every kind of regional protection available): ARIPO (BW, GH, GM, KE, LS, MW, MZ, NA, SD, SL, SZ, TZ, UG, ZM, ZW), Eurasian (AM, AZ, BY, KG, KZ, MD, RU, TJ, TM), European (AT, BE, BG, CH, CY, CZ, DE, DK, EE, ES, FI, FR, GB, GR, HR, HU, IE, IS, IT, LT, LU, LV, MC, MT, NL, NO, PL, PT, RO, SE, SI, SK, TR), OAPI (BF, BJ, CF, CG, CI, CM, GA, GN, GQ, GW, ML, MR, NE, SN, TD, TG).

(71) Applicant (for all designated States except US): AGCO GMBH [DE/DE]; Johann-Georg-Fendt Strasse 4, 87616 Marktoberdorf (DE).

(72) Inventors; and

(75) Inventors/Applicants (for US only): BAYER, Klaus [DE/DE]; Johann-Brahms Strasse 10, 87616 Marktoberdorf (DE). KRIEGER, Sven [DE/DE]; Alfons-Wanner-Str. 8, 87616 Marktoberdorf (DE). HONZEK,

Published:
— with international search report

(54) Title: BRAKE FOR UTILITY VEHICLE

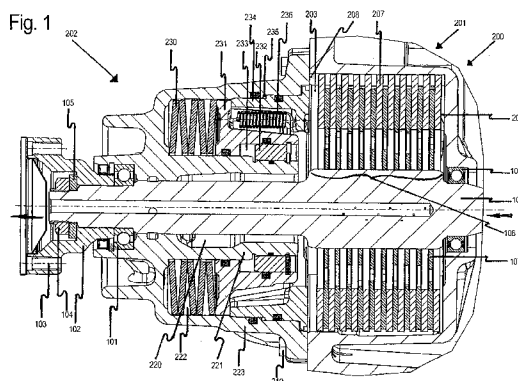

(57) Abstract: A brake mechanism for a utility vehicle which can be installed around a drive shaft or inside a wheel hub. The brake has a non rotatable fixed body (200), a rotatable body (100) rotatable relative to the fixed body (200), at least one brake disc (207) which is non-rotatably relative to the fixed body (200), and at least one rotating brake disc (107) which is fixed for rotation with the rotatable body (100). An actuating member (234) can press the fixed brake disc (207) and the rotating brake disc (107) against each other and against a stop surface (209) on the fixed body to apply the brake. A spring means (230) also exerts an immobilising force on the actuating member (234) to press the fixed brake disc (207) and the rotating brake disc (107) against each other to apply the brake. A brake release means (231,233) can exert a brake release force which counteracts the immobilising force of the spring so that the actuating member (234) no longer presses the fixed brake disc (207) and the rotating brake disc (107) against each other, and a brake applying means (235) can exert a pushing force on the actuating member (234) in the same direction as the immobilising force to press the fixed brake disc (207) and the rotating brake disc (107) against each other to apply the brake.

WO 2009/059720 A1

Brake for Utility Vehicle

The invention relates to a brake for use in an agricultural utility vehicle, for example a tractor, which includes both a parking brake and a service brake. Such a brake can be housed in a drive train of the vehicle or in a wheel hub of the vehicle.

During operation of agricultural utility vehicles it is necessary to provide service brakes and parking brakes which, owing to the great weight of the vehicle and the towed loads as well as owing to legal regulations, have to fulfil certain performance requirements. It is therefore necessary for a service brake on at least one axle downstream of the differential to have to be able to act independently on the left and right wheel in each case in agricultural utility vehicles. Furthermore it is conventional for a parking brake to be able to act as an auxiliary brake on the two wheels respectively of at least one axle in order to satisfy statutory provisions.

It is well known to provide brakes on the rear axle of a tractor acting on drive shafts on either side of the differential, on a drive shaft which powers the front axle in order to brake both front wheels, and also in the wheel hub of a driven or non-driver wheel.

It is an object of the present invention to provide a brake mechanism which is of a compact construction and which is suitable for use to provide a parking and service brake function on a drive shaft or in a wheel hub.

Thus according to the present invention there is provided a brake mechanism for a utility vehicle comprising:

- a non rotatable fixed body,
- a rotatable body rotatable relative to the fixed body,
- at least one brake disc which is non-rotatably relative to the fixed body,
- at least one rotating brake disc which is fixed for rotation with the rotatable body,
- a stop surface on the fixed body,
- an actuating member which can press the fixed brake disc and the rotating brake disc against each other and against the stop surface to apply the brake,

a spring means which exerts an immobilising force on the actuating member to press the fixed brake disc and the rotating brake disc against each other to apply the brake,
a brake release means which can exert a brake release force which counteracts the immobilising force of the spring so that the actuating member no longer presses the fixed brake disc and the rotating brake disc against each other, and
brake applying means which can exert a pushing force on the actuating member in the same direction as the immobilising force to press the fixed brake disc and the rotating brake disc against each other to apply the brake.

As a result of the fact that the parking brake and the service brake act on the discs from the same side and therefore only one actuating device is necessary for the parking brake and the service brake, the space requirement and structural weight may advantageously be reduced by omission and simplification of components.

The actuating member may be an annular actuating piston slidable in a bore in the fixed body.

The brake applying means may be an annular hydraulic chamber which acts on the annular actuating piston.

The brake release means may be an annular brake release piston on which a brake release hydraulic chamber acts, the brake release piston acting in the opposite direction to the spring means.

The spring means preferably act on the annular brake piston which in turn acts on the annular actuating piston which in turn presses the brake discs into contact to apply the brake.

This above construction provides simple components with small dimensions.

The force application points of the immobilising force, brake release force and pushing force act in an approximately straight line. This again allows small components due to the line of application of the forces.

The annular actuating piston is constructed at least partially around the annular brake release piston. This saves further space in the axial direction.

If the brake mechanism is arranged on a gear output shaft or if the rotatable body is a gear output shaft and the fixed body is a gear casing then this advantageously allows the parking brakes or combined parking and service brakes on a rear axle or front axle to be omitted.

The need for a parking brake on both wheels of the respective axle is dispensed with by providing the brake mechanism upstream of the axle differential. The number of components, the installation space and the costs are reduced as a result.

If the brake mechanism arranged on a gear output shaft is a wet brake then the brake mechanism can, despite relatively high speeds of the gear output shaft, advantageously ensure effective and efficient cooling and wear reduction both in the case of a service brake and in the case of an auxiliary or parking brake via the gear oil supply which is already equipped with efficient cooling and filtering devices.

If the brake mechanism is arranged on shaft between the gear and the differential of a front or rear axle the brake mechanism can be provided as an inherently enclosed module, and this facilitate maintenance, repair and replacement.

If the brake release annular piston and actuating annular piston can be brought into contact across a common supporting plane at an end face in each case, a large force can advantageously be transmitted across a large area with low surface pressure.

Use of a disc spring assembly, which is coaxial with the gear output shaft, as a spring means advantageously allows a high immobilising force with a compact design.

Use of a plurality of radially distributed spring assemblies instead of the disc spring assembly which is coaxial with the gear output shaft advantageously allows greater redundancy, and therewith reliability, on the one hand and greater flexibility in the configuration of the location of the spring means on the other.

A brake mechanism in accordance with the present invention is also suitable for use in a wheel hub when the rotatable body is a wheel housing and the fixed body is a wheel bearer or a component non-rotatably connected thereto.

The brake mechanism of the present invention will now be described, by way of example, with the aid of several embodiments and with reference to the following drawings in which:-

Fig 1 shows a sectional view of a drive shaft brake according to a first embodiment;

Fig 2 shows a sectional view of a drive shaft brake according to a second embodiment;

Fig 3 shows a partially cut perspective view of a wheel drive shaft and a wheel head with rim using a brake mechanism in accordance with the present invention;

Fig 4 shows a vertical section through the wheel head of Figure 2;

Fig 5 shows a vertical section through in more detail of the lower half of Figure 4;

Fig 6 shows a vertical section in more detail of the upper half of Figure 4;

Fig 7 shows part of Figure 6 and on a larger scale, and

Fig 8 shows a perspective view of annular pistons used in a brake mechanism according to the invention.

An overview of the construction of the drive shaft brake will be given hereinafter.

Speed and torque are generated by an engine (not shown), usually an internal combustion engine, and are transmitted by a clutch (not shown) to a conventional continuously variable gear (not shown). Speed and torque, optionally changed by the gear, are transmitted to a drive train (not shown) of a rear axle (not shown). Speed and torque are transmitted by a four-wheel engaging clutch (not shown) to a gear or drive output shaft 100 for driving a drive train (not shown) for a front axle. The gear output shaft 100 is rotatably mounted about its

axis of rotation in a gear casing 200 via bearings 101. A fastening flange 102 with drill holes 103 is provided at its output end in order to be connected to the drive train for the front axle. The fastening flange 102 is axially fixed by a nut 104 between a plate 105 and one ball bearing 101 and is non-rotatably connected to the gear output shaft 100 by interference fit, teeth or a feather key connection. A disc region 106, in which the diameter of the shaft 100 is enlarged to reduce a tangential force for transmission, is situated at the end of the gear output shaft 100 adjacent the gear. A plurality of rotatable brake discs 107 are arranged in this region and via external teeth (not shown) of the gear output shaft 100 are axially displaceably but non-rotatably connected thereto.

The gear casing 200 will be described hereinafter.

The gear casing 200 is constructed in two parts and comprises a brake disc casing 201 and an actuating casing 202. The brake disc casing 201 surrounds a cylindrical disc chamber 203 which receives the disc region 106 of shaft 100 and the brake discs 107. Furthermore, stationary casing brake discs 207 are provided so as to alternate with the rotatable brake discs 107. The casing brake discs 207 are non-rotatably connected to the disc casing 201 by projections 208 and can be axially displaced relative to casing 201. The axial displacement capacity of the casing brake discs 207 is limited in one direction by a stop mechanism in the form of a pressure plate 209 on a back wall of the disc casing 201. Gear oil is located in the disc chamber 203 and is connected by an opening (not shown) to the gear oil from the gear, so an exchange of gear oil may take place. The gear oil can be cleaned and cooled by suitable mechanisms.

The actuating casing 202 is securely connected to the disc casing 201 by screws 210. The actuating casing 202 has a hole and a cavity 220 in which the gear output shaft 100 is arranged. Separated therefrom by an encircling inner partition 221 there is provided an encircling hollow cylinder shaped actuating chamber 222. This is radially limited by the outer wall 223 of the actuating casing 202. The actuating chamber 222 is axially limited at one side by the outer wall 223 again and opens at the other side toward the disc chamber 203.

The mechanism for a parking brake and a service brake will be described hereinafter.

A disc spring assembly 230 is provided in the actuating chamber 222 so as to rest on the closed axial side thereof and encircle the inner partition 221. Supported by the outer wall 223 the disc spring assembly 230 exerts an immobilising force on a parking brake annular piston 231.

The parking brake annular piston 231 has an axial contact surface on a radial, flange-like projection which at one side rests on the disc spring assembly 230. An encircling projection of the parking brake annular piston 231 extends axially in the direction of the open side of the actuating chamber 222. At its inner circumferential surface the parking brake annular piston 231 has a rectangular change in radius to form a parking brake piston chamber 233. The outer circumferential surface of the inner partition 221 defines the inner circumferential surface of the parking brake piston chamber 233. Moreover a ring 232 is provided on the inner partition 221 and is axially fixed thereto by a circlip ring. One end face of the ring 232 forms the other end face of the parking brake piston chamber 233. The parking brake piston chamber 233 can be filled with a pressurised hydraulic fluid by a hydraulic system (not shown), whereby a brake release force which counteracts the immobilising force of the spring assembly 230 is generated by the parking brake annular piston 231.

One end face of a service brake annular piston 234 rests on a radially outer region of an end face of the radial flange of the parking brake annular piston 231. The service brake annular piston 234 also rests axially displaceably on the inner circumferential surface of the outer wall 223. A service brake piston chamber 235 is formed by a rectangular change in radius at the inner circumferential surface of the outer wall 223 and by a further rectangular change in radius at the outer circumferential surface of the service brake annular piston 234. The service brake piston chamber 235 can be filled with a hydraulic fluid by a service brake hydraulic system (not shown). If the service brake piston chamber 235 is filled with a pressurised hydraulic fluid a pushing force is generated by the service brake annular piston 234 in the direction of the axle brake discs 107 and the casing brake discs 207. These are pressed against the pressure plate 209 and in the process are simultaneously pressed against each other. If hydraulic fluid is released from the service brake piston chamber 235, the service brake annular piston 234 is pulled away from discs 107 and 207 by a restoring spring 236, which is tensioned between the parking brake annular piston 231 and the service brake annular piston 234, in the direction of the parking brake annular piston 231. Thus the

rotatable brake discs 107 and the stationary brake discs 207 are not pushed against each other any more.

The function of the brake mechanism will be described hereinafter.

The immobilising force is generated via the disc spring assembly 230 and is transmitted by the parking brake annular piston 231 and the service brake annular piston 234 to the rotatable brake discs 107 and the stationary brake discs 207 so they are pressed against the pressure plate 209, whereby the brake discs 107 and 207 are pressed against each other. The gear output shaft 100 is thus rotationally fixed by the resulting friction and the parking brake function is operating.

To release the parking brake, hydraulic fluid is pumped into the parking brake piston chamber 233 and the parking brake annular piston 231 is moved counter to the immobilising force of the spring assembly 230. The service brake annular piston 234 is also moved in the same direction by the restoring spring 236. The friction between the brake discs 107 and 207 is thus cancelled so that the gear output shaft 100 can freely rotate.

If a driver actuates the service brake while the gear output shaft 100 is rotating fluid is pumped into the service brake piston chamber 235 and the service brake annular piston 234 is moved towards the discs 107 and 207 counter to the force of the restoring spring 236 and without the parking brake annular piston 231. The discs 107 and 207 are pressed together by the pushing force generated thereby and the friction between them increases, whereby rotation of the gear output shaft 100 is decelerated. The frictional heat that is generated in the process is dissipated via the gear oil which at least partially surrounds the discs 107 and 207.

In a case in which the hydraulic system for parking brake and service brake should fail, for example owing to a technical defect, hydraulic fluid escapes from the parking brake piston chamber 231 and the service brake piston chamber 235. In this case the parking brake annular piston 231 and the service brake annular piston 234 are pressed against the brake discs 107 and 207 by the immobilising force of the disc spring assembly 230. In this case a braking effect takes place in a manner comparable to in the preceding section. Since the same

components are involved in braking here as in a conventional case of service braking, there need be no fear of the parking brake being overloaded.

Fig. 2 shows a drive shaft brake which is substantially the same construction as the first embodiment and only the differences from the first embodiment will be discussed hereinafter.

In the second embodiment the actuating casing 202' is constructed in two parts from an actuating casing head 202a and an actuating casing ring 202b. As in the first embodiment a disc spring assembly 230 is accommodated in an actuating chamber 222. A parking brake annular piston 231' is constructed in such a way that it forms a parking brake piston chamber 233' via a change in the radius of its outer circumferential surface and the inner circumferential surface of the actuating casing ring 202b respectively. At one end face it is located along its outer circumference on a service brake annular piston 234, which is constructed as in the preceding embodiment. The force application points of the immobilising force, the brake release force and the pushing force are arranged in an approximately straight line. This means the immobilising force, the brake release force and the pushing force also act in individual force components along or counter to a common linear force flow. They therefore act coaxially even in individual force components. The disc spring assembly 230, the parking brake annular piston 231', the parking brake hydraulic chamber 233', the service brake annular piston 234, the service brake piston chamber 235 and the brake disc assembly are arranged in a line so as to be aligned with one another. This relates not only to the case in which all of the forces of the annular elements are considered, but in particular the case in which individual segments of the annular elements are considered.

Since in this case almost exclusively normal forces and only small shearing forces or bending moments or forces act on the force-transmitting elements, it is possible to make the elements smaller and to reduce the weight accordingly.

It is obvious to a person skilled in the art that modifications to the invention are possible without departing from the inventive idea.

By way of example: with a large internal radius of the actuating chamber 222 it may be necessary to distribute a plurality of spring assemblies over the circumference of the

actuating chamber 222 instead of one disc spring assembly which is coaxial to the gear output shaft. Other types of spring may also be used moreover which are coaxially arranged or radially distributed.

In the case of low speeds or low braking forces the brake according to the invention can also be constructed as a dry brake, or instead of the disc assemblies can be constructed with a brake disc or a brake disc and brake shoe respectively.

In the embodiment the brake mechanism is integrated in the gear. The shaft leading into the brake is therefore called the gear output shaft and the casing surrounding the brake mechanism the gear casing. The brake mechanism can also be provided outside of the gear and at any desired spacing therefrom, connected by a shaft which is drive-coupled to the gear output shaft.

Figures 3 to 8 show the brake mechanism of the present invention applied to a wheel hub.

Fig. 3 shows a partially cut perspective view of a final drive of a wheel 1 in an agricultural utility vehicle. A drive moment is transmitted in a drive train (not shown) from an internal combustion engine (not shown) via speed-transforming gears and differentials (not shown) to a drive shaft 400 (cf. Fig. 4). Since the wheel 1 is steered wheel in this embodiment a joint 401 is provided via which the drive moment is transmitted from the drive shaft 400 to a hub shaft 402 even if drive shaft 400 and the hub shaft 402 are at an angle to each other.

A fixed body in the form of a wheel bearer 500 is connected by steering bearings 501 to the vehicle body in such a way that the wheel bearer 500 can be swivelled about the axis D relative to the vehicle body. The hub shaft 502 is mounted in a hole 502 centrally located in the wheel bearer 500. The wheel bearer 500 is connected by the steering bearings 501 to a vehicle body in such a way that it cannot twist relative to the body about an axis formed by the hub shaft 502.

A rotational body in the form of a wheel head 600 is arranged around the wheel bearer 500 and is rotatably mounted on the wheel bearer 500. A wheel rim 601 is fastened to the wheel

head 600. The wheel head 600 is driven by the hub shaft 402 via a planetary gear set 700 and rotates about its axis of symmetry around the wheel bearer 500.

Although the wheel bearer 500 and the wheel head 600 are each made from multiple pieces, they have each been provided with uniformly oriented hatching to increase the clarity in the cut views Figs. 4 to 7. Using the hatching orientation it is therefore possible to see whether a component is rotatable about an axis formed by the hub shaft 402 or is fixed.

The final drive of wheel 1 and the planetary gear set 400 will be described hereinafter.

As may be seen in Fig. 4, the hub shaft 402 is mounted in the hole 502 via a ball bearing 404. An end portion of the hub shaft 402 forms a sun wheel 403 of the planetary gear set 700. Three planetary wheels 703 are mounted on the wheel head 600 via a planetary carrier 702 and are engaged by the sun wheel 403. A ring gear 503 is non-rotatably fastened to the wheel bearer 500 and is engaged with the planetary wheels 703. Since the wheel bearer 500, and therefore the ring gear 503, is non-rotatable with respect to the hub shaft 402 a rotation of the hub shaft 402 is reduced by the planetary gear set 700 and transmitted into a rotation of the planetary carrier 702. Since the planetary carrier 702 is connected by screws 704 to the wheel head 600, the wheel head 600 is rotated hereby. This results in a rotational speed of the wheel head 600 which is lower by a factor of ten to sixteen than the rotational speed of shaft 100 in the drive train.

The construction of the wheel head 600 will be described hereinafter.

As may be seen in Fig. 5, the wheel head 600 is mounted via tapered roller bearings 504 on the wheel bearer 500 so as to rotate about an axis formed by the hub shaft 402. The wheel head 600 is constructed in two pieces for assembly. An inner housing 605 is connected by screws 606 to an outer housing 607. The rim 601 is attached to the outer housing 607 by threaded bolts 608 and screw nuts 609. Inner housing 605 and outer housing 607 enclose a space which receives part of the wheel bearer 500 and the brake mechanisms described below. A plurality of rotatable brake discs in the form of wheel head brake discs 610 are arranged inside this cavity. The wheel head brake discs 610 are non-rotatably connected to

the wheel head 600 by internal teething 611, so they rotate with the wheel head. The wheel head brake discs 610 also exhibit axial displaceability with respect to the wheel head 600.

The construction of the wheel bearer 500 will be described hereinafter.

As is shown in Fig. 6, the wheel bearer 500 is constructed in multiple pieces for assembly and comprises a hub portion 507, a centre carrier 508, a stop mechanism in the form of a pressure plate 509, and a spring carrier 510. The pressure plate 509 and the spring carrier 510 are non-rotatably screwed to the centre carrier 508 by screws 511 (cf. Fig. 5). The centre carrier 208 is non-rotatably connected to the hub portion 507 by a spline fitting 515.

A plurality of fixed brake discs in the form of wheel bearer brake discs 512 are arranged between the centre carrier 508 and the pressure plate 509. These fixed brake discs are non-rotatably connected by external teething 513 to the centre carrier 508 and exhibit axial displaceability. The wheel bearer brake discs 512 and the wheel head brake discs 610 are alternately arranged and form a brake disc assembly. The wheel bearer brake discs 512 and the pressure plate 509 are kept at a distance by a restoring spring 514 and the brake disc assembly is thus opened. In this open state the wheel bearer brake discs 512 and the wheel head brake discs 610 can be moved relative to each other and the wheel head 600 can rotate relative to the wheel bearer 500.

At least two axial holes 520, 521 are provided in the hub portion 507 and are connected by a groove 520' or 521'. The grooves 520', 521' are constructed in a surface of the hub portion 507 so as to be encircling and when assembled with the centre carrier 508 each form a channel. One or more radial hole(s) 522, which are provided in the centre carrier 508, are connected to the groove 520'. One or more radial hole(s) 523, which are provided in the centre carrier 508, are connected to the groove 521'. The axial holes 520, 521 are each connected to a hydraulic system and are used to bleed a parking brake or to actuate a service brake.

The mechanism for a parking brake and a service brake will be described hereinafter with reference to Figs.5 and 7.

Eight disc spring assemblies 524 are provided in the wheel bearer 500 between the spring carrier 510 and the centre carrier 508 and are distributed at equal intervals over the periphery of the spring carrier 510.

As shown in Fig. 5, the disc spring assemblies are displaceably located on guides 525. The guides 525 are arranged in indentations 526 which are provided in the spring carrier 510 and position the disc spring assemblies 524. The guide 525 is screwed to an edge of a parking brake annular piston 527 that is widened in the manner of a flange and the disc spring assembly 524 exerts an immobilising force on the parking brake annular piston 527 which acts to the right with respect to Fig. 7.

As may be seen in Fig. 8, the parking brake annular piston 527 is constructed as a ring around the periphery of the wheel bearer 500. As can be seen in Fig. 7, an encircling parking brake groove 528 is provided in the centre carrier 508 into which the parking brake annular piston 527 is placed. The bottom of the parking brake groove 528, together with the parking brake annular piston 527, forms a parking brake piston chamber 529 which is connected to the radial hole 523. This parking brake piston chamber 529 is used as a hydraulic chamber and can be filled with a hydraulic fluid via the radial hole 523. The thus produced stroke of the parking brake annular piston 527 generates a bleeding or brake releasing force which counteracts the immobilising force of the disc spring assemblies 524, whereby the spring assemblies 524 are pressed together between the parking brake annular piston 527 and the spring carrier 510. The parking brake piston chamber 529 is sealed by O-rings 530. Counteracting of the brake apply force will be called bleeding or brake releasing hereinafter.

Six intermediate pistons 531 are screwed to the parking brake annular piston at equal intervals from each other (cf. also Fig. 8). The intermediate pistons 531 sit in holes in the centre carrier 510 and project into an encircling service brake groove 532. A service brake annular piston 533 is provided in the service brake groove 532 and, together with the bottom of the service brake groove 532, forms a service brake piston chamber 534. The service brake piston chamber 534 is connected to the radial hole 522 and can be filled with a hydraulic fluid thereby. A pushing force acts on the service brake annular piston 533 as a result, whereby the piston is pushed out of the groove and against a wheel bearer brake disc 512.

The immobilising force is transmitted via the intermediate pistons 231 to the service brake annular piston 233.

The force application points of the immobilising force, the brake release force and the pushing force are arranged in a straight line. This means the immobilising force, the brake release force and the pushing force also act in individual force components along or counter to a common linear force flow. They therefore also act coaxially in individual force components. The spring assemblies 524, the parking brake annular piston 527, the parking brake hydraulic chamber 529, the intermediate pistons 531, the service brake hydraulic chamber 534, the service brake annular piston 534 and the brake disc assembly are arranged in a line so as to be aligned with each other. This applies not only to the case in which all of the forces of the annular elements are considered but in particular the case in which forces of the individual segments of the annular elements are considered. In other words, the annular force-transmitting components, such as the parking brake annular piston 527 and the service brake annular piston 534, are coaxial and have the same radius; the remaining force-transmitting components, such as the spring assemblies 524 and the intermediate pistons 531, are arranged on this radius. A cylindrical active plane with this radius is therefore produced, along which plane all forces act.

The function of the brake mechanism will be described hereinafter with reference to Fig. 7.

In the initial state the disc spring assembly 524 is supported on the spring carrier 210 and exerts an immobilising force on the parking brake annular piston 527 in the axial direction. This force is exerted via the intermediate pistons 531 on the service brake annular piston 533 in such a way that the brake disc assembly 512, 510 is pressed together between the service brake annular piston 533 and the pressure plate 509. Thus relative movement between the wheel bearer brake discs 512 and the wheel head brake discs 610 is prevented by friction, whereby rotation of the wheel head 600 relative to the wheel bearer 500 is prevented. A linear, straight force flow is produced in this connection and acts from the disc spring assemblies 524 via the parking brake annular piston 527, the intermediate pistons 531, the service brake piston 533 and the brake discs 512, 610 on the pressure plate 509.

If an operator releases the parking brake, the parking brake piston chamber 529 is filled with a hydraulic fluid and the parking brake annular piston 527 is pushed from the centre carrier 508, counter to the immobilising force of the disc spring assemblies 524. At the same time the service brake annular piston 533 is relieved of the immobilising force which is transmitted via the intermediate pistons 532. The wheel bearer brake discs 512 and the wheel head brake discs 610 can thereby be separated from each other via the restoring spring 514. The friction between the brake discs is cancelled hereby and the wheel head 600 can rotate relative to the wheel bearer 500.

If the service brake is actuated by an operator the service brake piston chamber 534 is filled with hydraulic fluid and the service brake annular piston is pushed from the service brake groove 533, counter to the force of the restoring spring 514, against one of the wheel bearer brake discs 512. The wheel bearer brake discs 512 and the wheel head brake discs 610 are pressed against each other again hereby and rotation of the wheel head 630 relative to the wheel bearer 500 is decelerated or halted by friction.

If the parking brake piston chamber 529 and the service brake piston chamber 534 loose hydraulic fluid in the event of failure of the hydraulic system, the immobilising force of the disc spring assembly 524 acts on the service brake annular piston 533 again, whereby, in a manner comparable to the service braking operation, rotation of the wheel head 600 relative to the wheel bearer 500 is decelerated. Since the brake disc assembly 512, 610 is acted on via the service brake annular piston 533 in this case as well, the parking brake, in addition to fixing a resting wheel 1, can decelerate and halt a rotating wheel 1 in the same manner as via the service brake, without overheating problems having to be anticipated as only service brake elements have to be employed within their intended use in this connection.

It is obvious to a person skilled in the art that the invention can also be used aside from the described embodiment. Thus it can also be used for example on a non-driven and/or non-steered wheel.

Claims

1. A brake mechanism for a utility vehicle, comprising:
 - a non rotatable fixed body (200),
 - a rotatable body (100) rotatable relative to the fixed body (200),
 - at least one brake disc (207) which is non-rotatably relative to the fixed body (200),
 - at least one rotating brake disc (107) which is fixed for rotation with the rotatable body (100),
 - a stop surface (209) on the fixed body (200),
 - an actuating member (234) which can press the fixed brake disc (207) and the rotating brake disc (107) against each other and against the stop surface (209) to apply the brake,
 - a spring means (230) which exerts an immobilising force on the actuating member (234) to press the fixed brake disc (207) and the rotating brake disc (107) against each other to apply the brake,
 - a brake release means (231,233) which can exert a brake release force which counteracts the immobilising force of the spring so that the actuating member (234) no longer presses the fixed brake disc (207) and the rotating brake disc (107) against each other, and
 - a brake applying means (235) which can exert a pushing force on the actuating member (234) in the same direction as the immobilising force to press the fixed brake disc (207) and the rotating brake disc (107) against each other to apply the brake.
2. A brake mechanism according to claim 1 wherein the actuating member is an annular actuating piston (234) slidable in a bore in the fixed body (200).
3. A brake mechanism according to claim 2 wherein the brake applying means is an annular hydraulic chamber (235) which acts on the annular actuating piston (234).
4. A brake mechanism according to any one of claims 1 to 3, wherein the brake release means is an annular brake release piston (231) on which a brake release

hydraulic chamber (233) acts, the brake release piston acting in the opposite direction to the spring means (230).

5. A brake mechanism according to any one of claims 1 to 4 wherein the spring means acts on the annular brake release piston (231) which in turn acts on the annular actuating piston (234) which in turn presses the brake discs (107,207) into contact to apply the brake.
6. A brake mechanism according to any one of claims 1 to 5, wherein force application points of the immobilising force, brake release force and pushing force are arranged in an approximately straight line.
7. A brake mechanism according to claim 5, wherein the annular actuating piston (234) is constructed at least partially around the annular brake release piston (231).
8. A brake mechanism according to any one of claims 1 to 7, wherein the spring means is a disc spring assembly (230).
9. A brake mechanism according to any one of claims 1 to 7, wherein the spring comprises a plurality of radially distributed coil spring assemblies.
10. A brake mechanism according to any one of claims 1 to 10 wherein the rotatable body (100) is a gear output shaft and the fixed body (200) is a gear casing or a device non-rotatably connected thereto.
11. A brake mechanism according to any one of claims 1 to 10 wherein the rotatable body (100) is a shaft which is arranged between a drive gear and differential of a front or rear axle.
12. A brake mechanism according to any one of claims 1 to 10 wherein the rotatable body (600) is a wheel head housing and the fixed body (500) is a wheel bearer or a component non-rotatably connected thereto.

13. A brake mechanism according to any one of the preceding claims, wherein the brake mechanism is a wet brake.

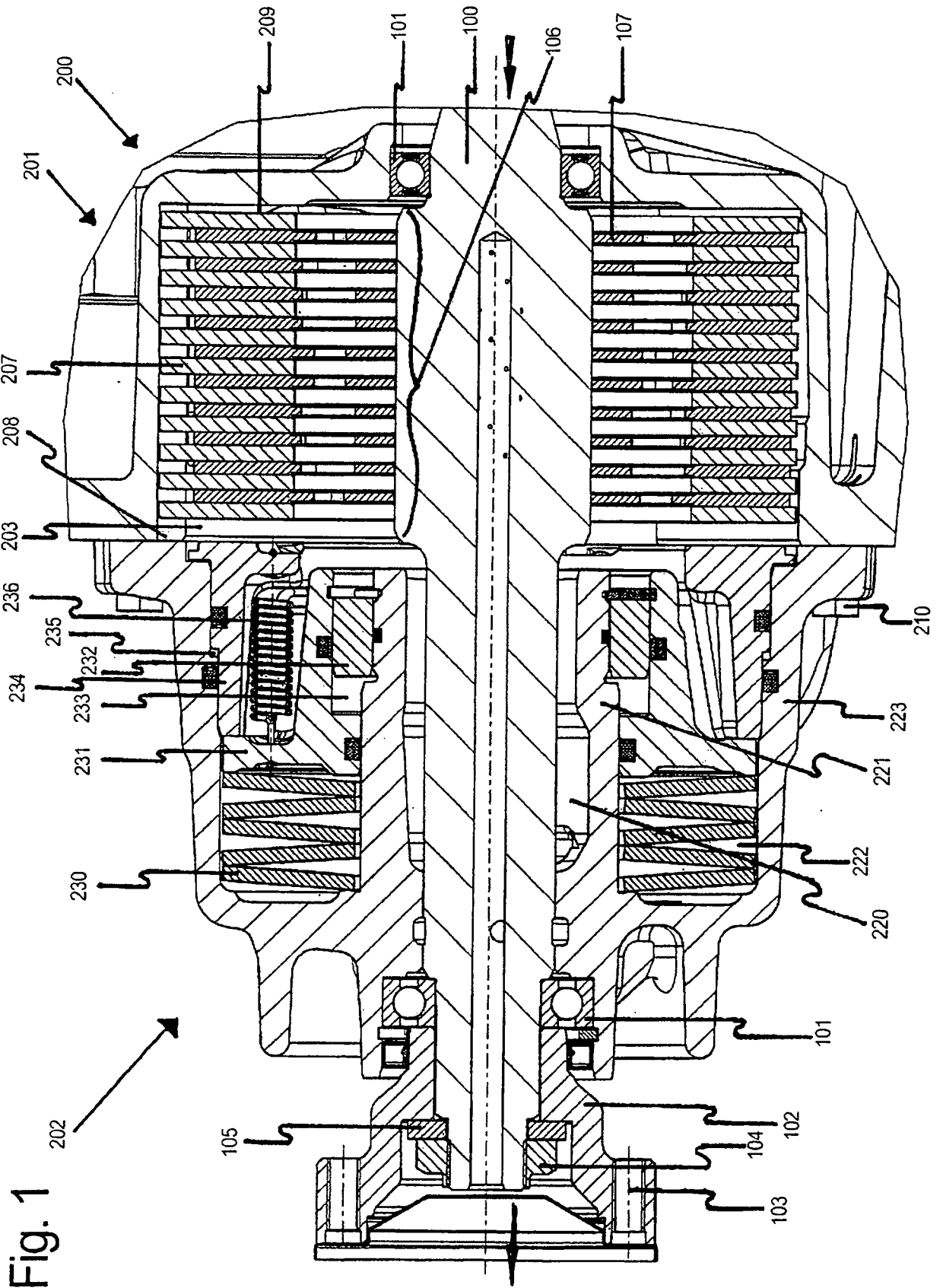

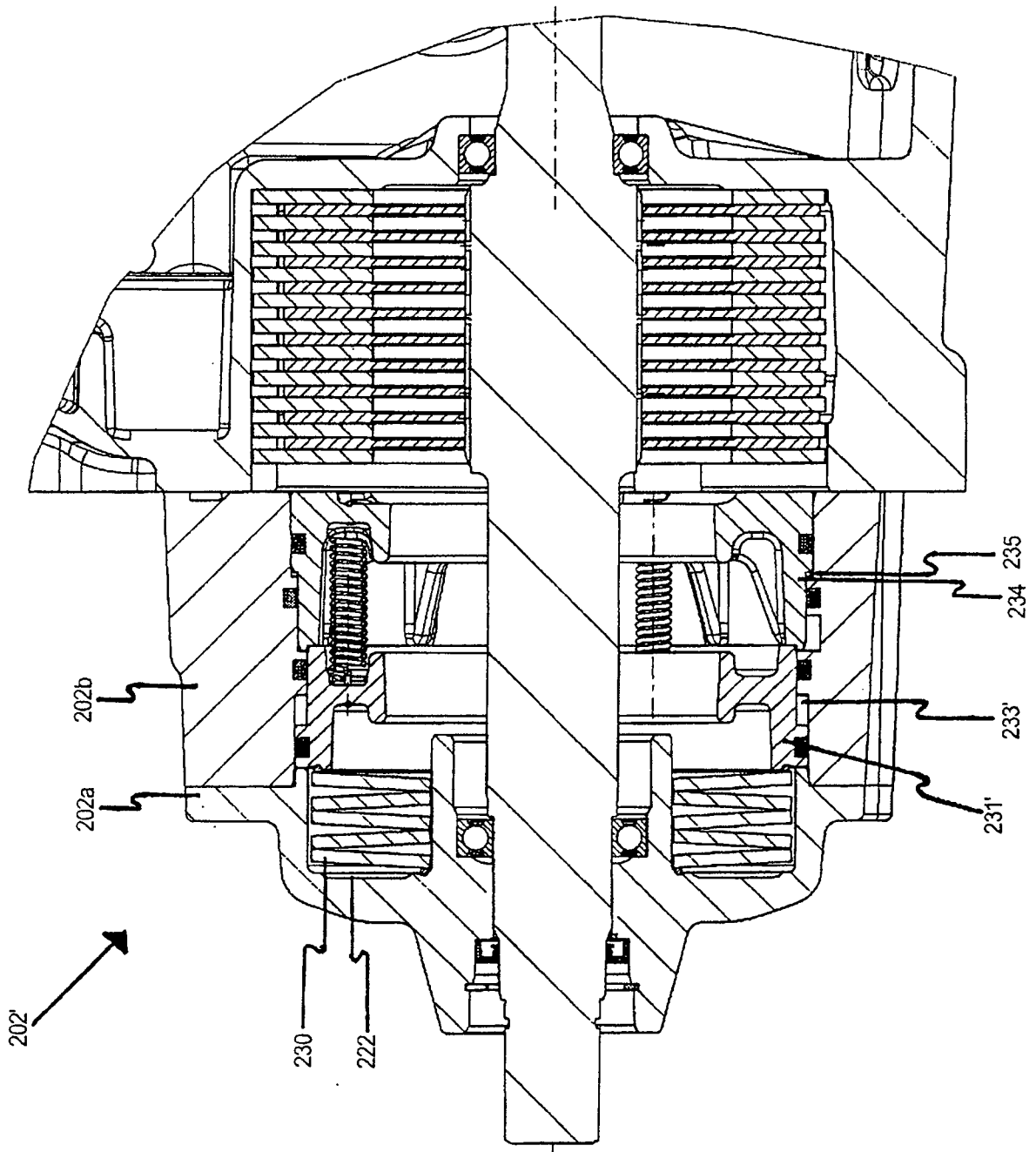

Fig. 2

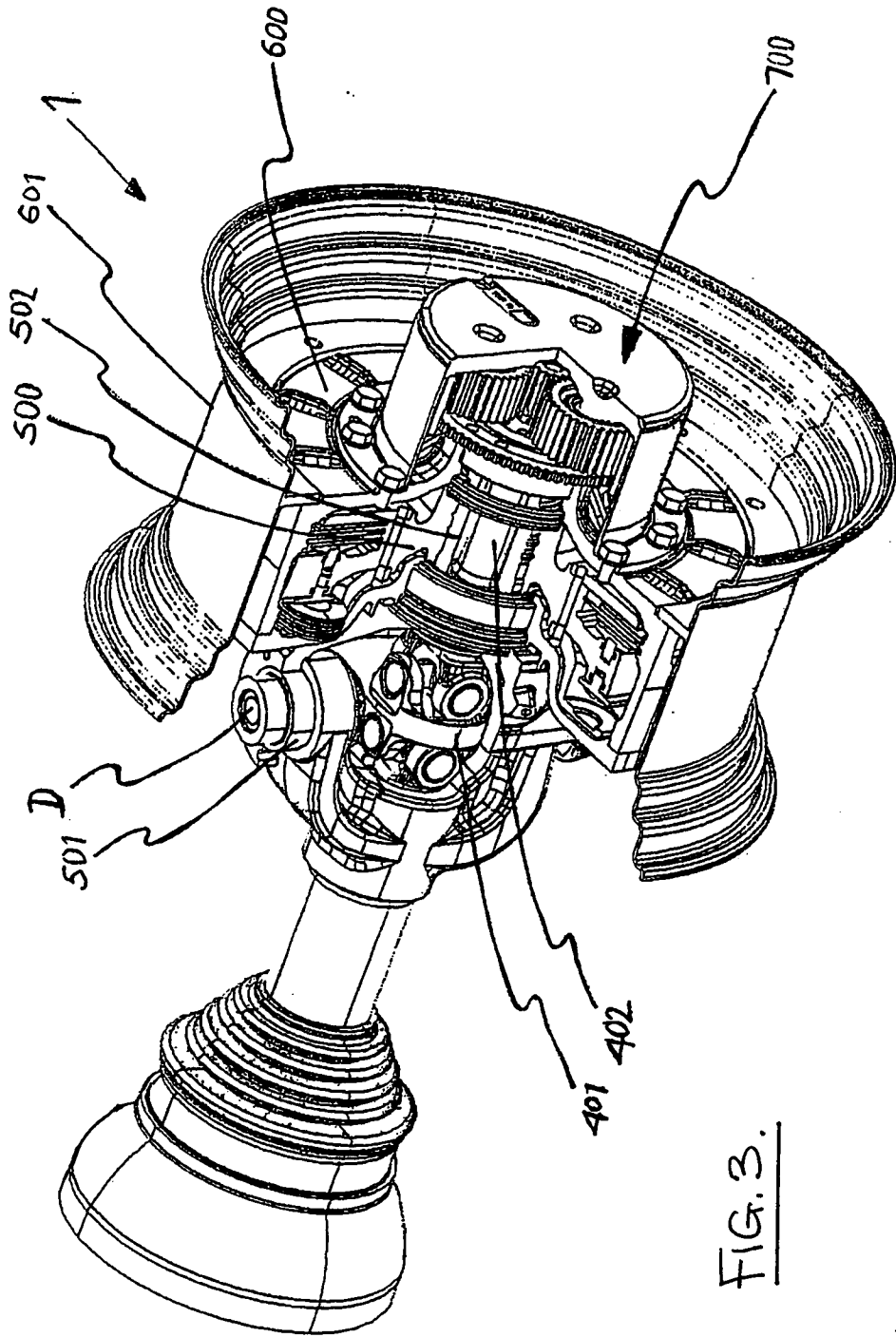

FIG. 3.

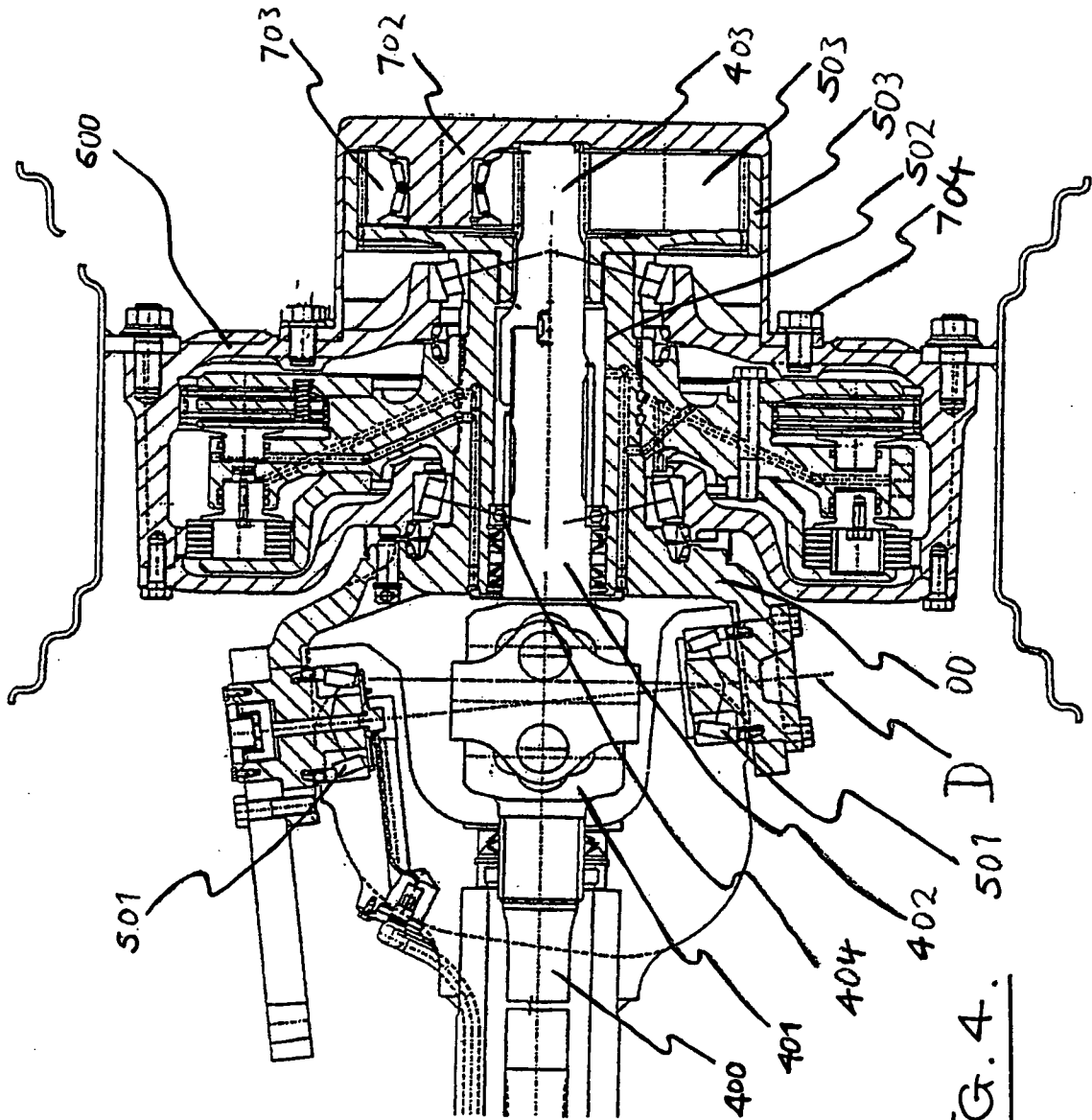

FIG. 4.

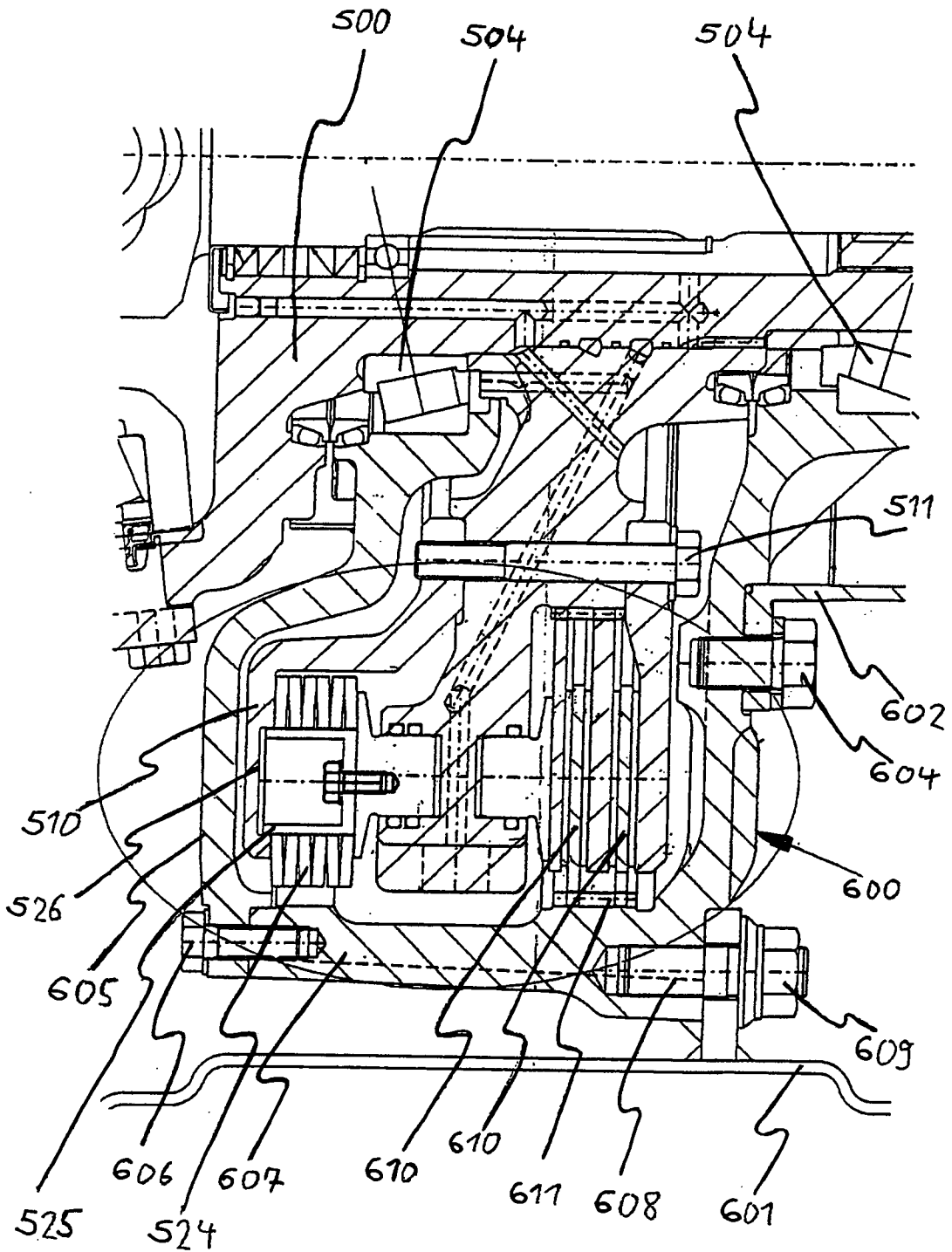

FIG. 5.

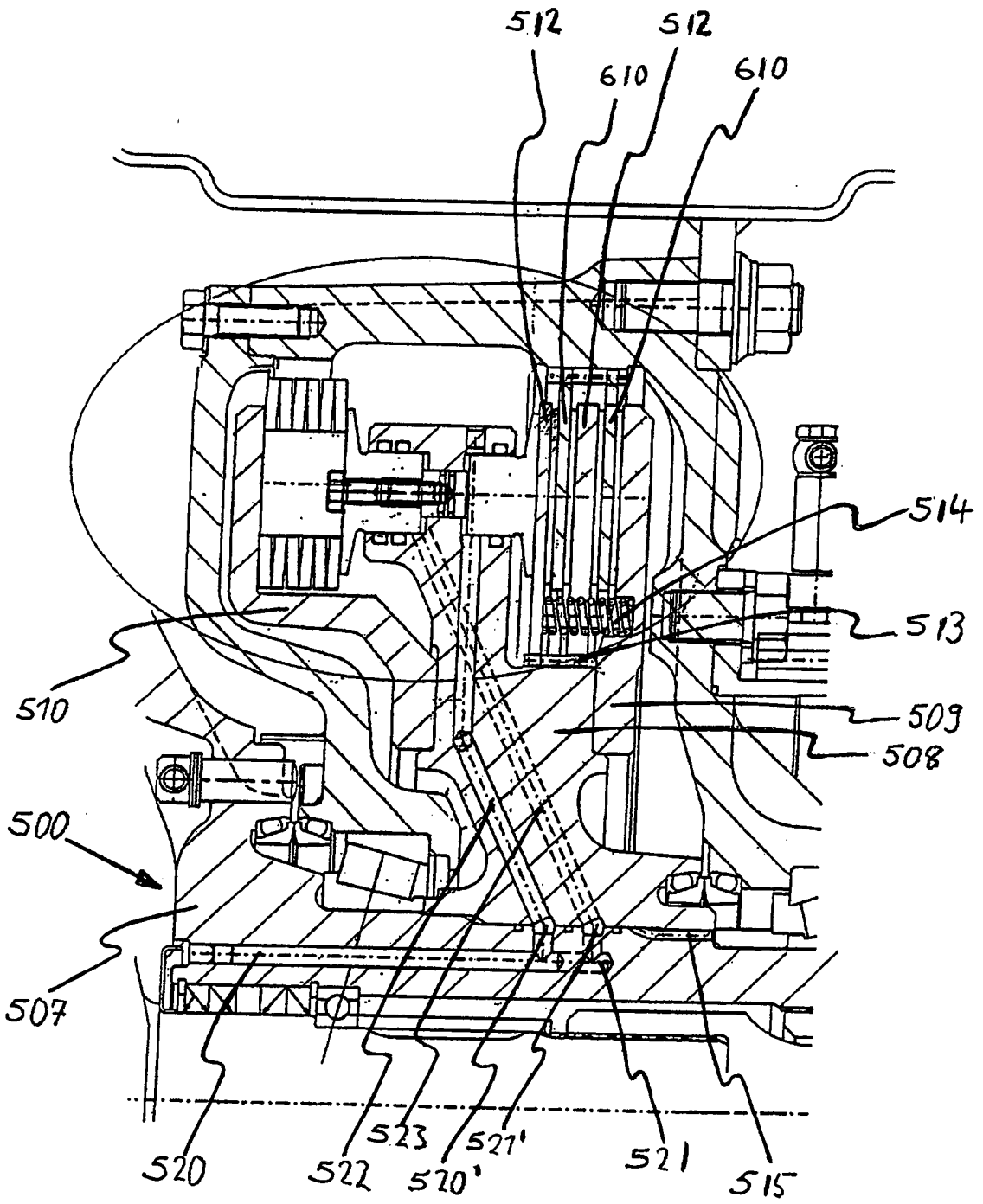

FIG. 6.

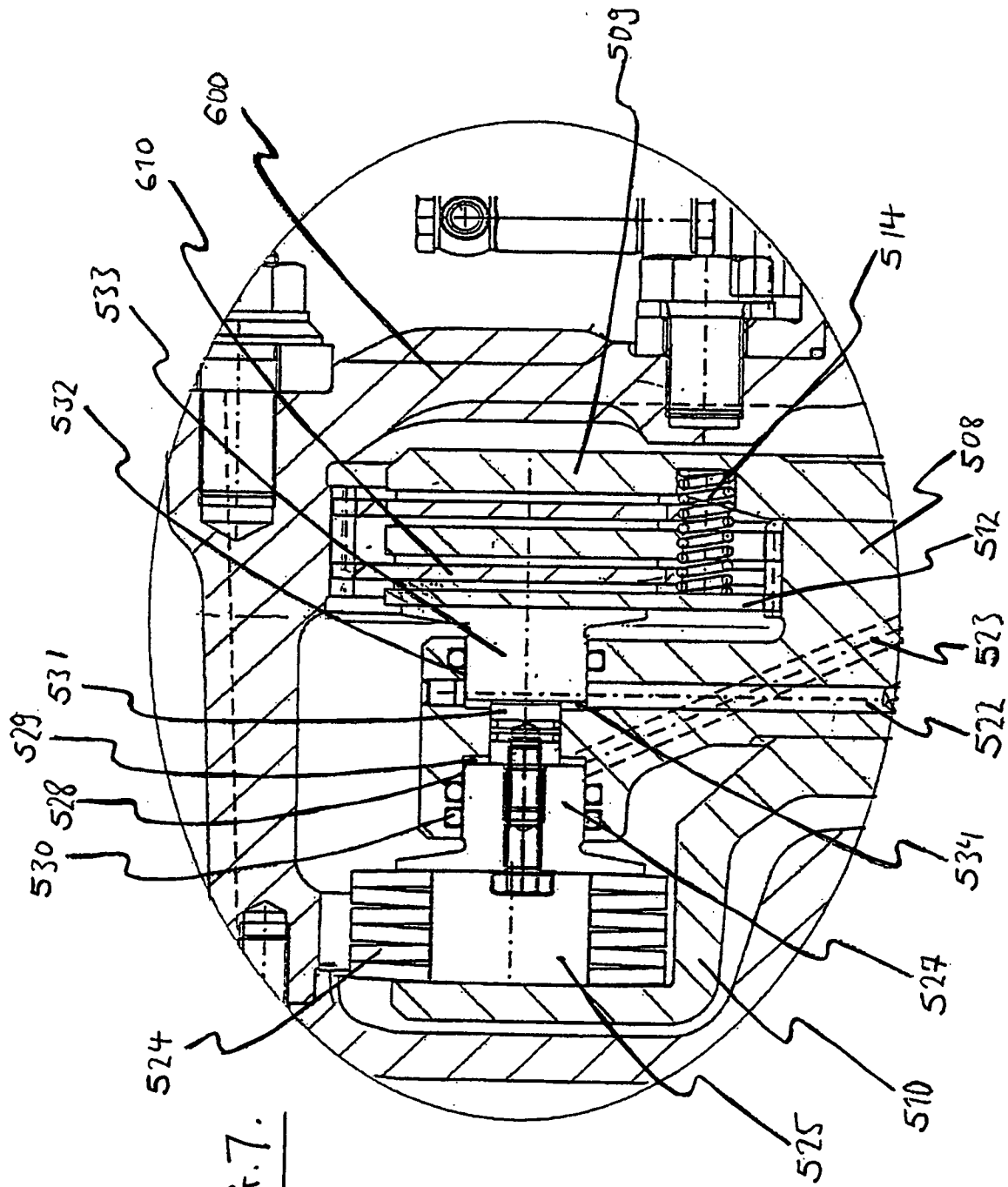

FIG. 7.

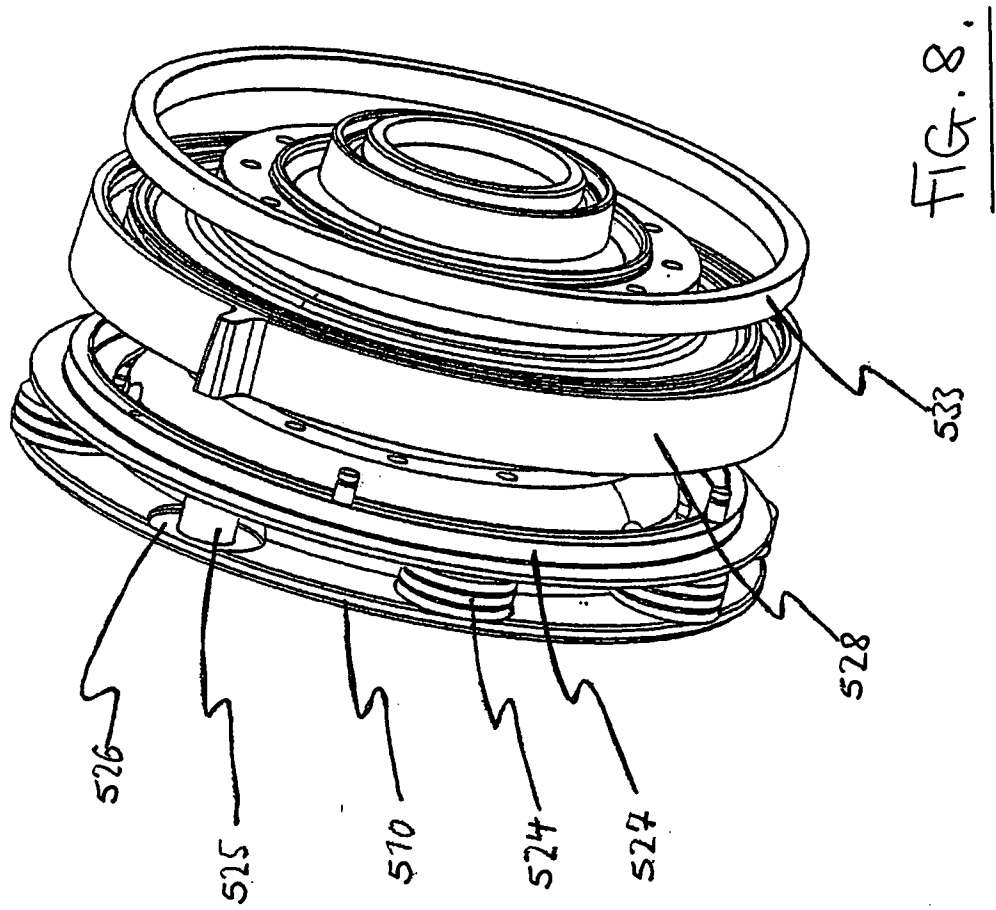

FIG. 8.

INTERNATIONAL SEARCH REPORT

International application No
PCT/EP2008/009157

A. CLASSIFICATION OF SUBJECT MATTER
 INV. B60T1/06 F16D55/40 F16D65/14 F16D55/00 B60K17/04

According to International Patent Classification (IPC) or to both national classification and IPC

B. FIELDS SEARCHED
 Minimum documentation searched (classification system followed by classification symbols)
 F16D B60T

Documentation searched other than minimum documentation to the extent that such documents are included in the fields searched

Electronic data base consulted during the international search (name of data base and, where practical, search terms used)
 EPO-Internal

C. DOCUMENTS CONSIDERED TO BE RELEVANT

Category*	Citation of document, with indication, where appropriate, of the relevant passages	Relevant to claim No.
X	FR 2 796 886 A (POCLAIN HYDRAULICS IND [FR]) 2 February 2001 (2001-02-02) page 8; figure 1	1-13
X	EP 1 067 305 A (TEIJIN SEIKI CO LTD [JP] NABTESCO CORP [JP]) 10 January 2001 (2001-01-10) column 7; figure 1	1
X	DE 199 03 564 A1 (LINDE AG [DE]) 3 August 2000 (2000-08-03) abstract; figure	1
X	EP 0 913 304 A (CARRARO SPA [IT]) 6 May 1999 (1999-05-06) abstract; figure 1	1
	-/--	

Further documents are listed in the continuation of Box C. See patent family annex.

* Special categories of cited documents :

A document defining the general state of the art which is not considered to be of particular relevance	*T* later document published after the international filing date or priority date and not in conflict with the application but cited to understand the principle or theory underlying the invention
E earlier document but published on or after the international filing date	*X* document of particular relevance; the claimed invention cannot be considered novel or cannot be considered to involve an inventive step when the document is taken alone
L document which may throw doubts on priority claim(s) or which is cited to establish the publication date of another citation or other special reason (as specified)	*Y* document of particular relevance; the claimed invention cannot be considered to involve an inventive step when the document is combined with one or more other such documents, such combination being obvious to a person skilled in the art.
O document referring to an oral disclosure, use, exhibition or other means	*&* document member of the same patent family
P document published prior to the international filing date but later than the priority date claimed	

Date of the actual completion of the international search 30 January 2009	Date of mailing of the international search report 05/02/2009
--	--

Name and mailing address of the ISA/ European Patent Office, P.B. 5818 Patentlaan 2 NL - 2280 HV Rijswijk Tel. (+31-70) 340-2040, Fax: (+31-70) 340-3016	Authorized officer Pemberton, Paul
--	---

INTERNATIONAL SEARCH REPORT

International application No

PCT/EP2008/009157

C(Continuation). DOCUMENTS CONSIDERED TO BE RELEVANT

Category*	Citation of document, with indication, where appropriate, of the relevant passages	Relevant to claim No.
X	EP 0 684 402 A (CLARK HURTH COMPONENTS SPA [IT]) 29 November 1995 (1995-11-29) column 3; figures -----	1
X	EP 1 329 643 A (ZAHNRADFABRIK FRIEDRICHSHAFEN [DE]) 23 July 2003 (2003-07-23) abstract; figures -----	1
X	US 2001/053730 A1 (PANIZZOLO FABRIZIO [IT]) 20 December 2001 (2001-12-20) abstract; figures -----	1
X	WO 2005/001304 A (LOHMANN & STOLTERFOHT GMBH [DE]; GRIMM RAIMUND [DE]; LANGENBECK BERNHA) 6 January 2005 (2005-01-06) abstract; figures -----	1
X	EP 1 500 839 A (TOYOTA JIDOSHOKKI KK [JP]) 26 January 2005 (2005-01-26) abstract; figures -----	1
X	EP 1 584 834 A (SAME DEUTZ FAHR SPA [IT]) 12 October 2005 (2005-10-12) abstract; figures -----	1
X	GB 1 504 073 A (CATERPILLAR TRACTOR CO [US]) 15 March 1978 (1978-03-15) claim 1; figure -----	1
X	GB 1 572 153 A (GKN AXLES) 23 July 1980 (1980-07-23) claim 1; figures -----	1
X	US 4 024 936 A (CRABB ELMER R) 24 May 1977 (1977-05-24) abstract; figure 2 -----	1
X	US 5 050 710 A (BARGFREDE BRENT C [US]) 24 September 1991 (1991-09-24) abstract; figure 2 -----	1
X	WO 83/03124 A (CATERPILLAR TRACTOR CO [US]) 15 September 1983 (1983-09-15) abstract -----	1

INTERNATIONAL SEARCH REPORT

Information on patent family members

International application No

PCT/EP2008/009157

Patent document cited in search report		Publication date		Patent family member(s)	Publication date
FR 2796886	A	02-02-2001	DE	10035196 A1	08-03-2001
			US	6357558 B1	19-03-2002
EP 1067305	A	10-01-2001	DE	60019685 D1	02-06-2005
			DE	60019685 T2	13-10-2005
			JP	2001020847 A	23-01-2001
			US	6336323 B1	08-01-2002
DE 19903564	A1	03-08-2000	JP	2000227133 A	15-08-2000
EP 0913304	A	06-05-1999	AT	265342 T	15-05-2004
			DE	69823451 D1	03-06-2004
			DE	69823451 T2	07-04-2005
			IT	1296239 B1	18-06-1999
			US	6152269 A	28-11-2000
EP 0684402	A	29-11-1995	DE	69516330 D1	25-05-2000
			DE	69516330 T2	23-11-2000
			IT	MI940373 U1	20-11-1995
EP 1329643	A	23-07-2003	DE	10201366 A1	24-07-2003
US 2001053730	A1	20-12-2001	AT	358788 T	15-04-2007
			DE	60127615 T2	03-01-2008
			DK	1162383 T3	13-08-2007
			EP	1162383 A2	12-12-2001
			ES	2284584 T3	16-11-2007
			IT	MI20001294 A1	10-12-2001
WO 2005001304	A	06-01-2005	BR	PI0411993 A	29-08-2006
			CA	2531030 A1	06-01-2005
			CN	1813142 A	02-08-2006
			DE	10329047 A1	20-01-2005
			EP	1639268 A1	29-03-2006
			US	2006144651 A1	06-07-2006
EP 1500839	A	26-01-2005	DE	602004007438 T2	30-04-2008
			JP	2005042745 A	17-02-2005
EP 1584834	A	12-10-2005	NONE		
GB 1504073	A	15-03-1978	CA	1056742 A1	19-06-1979
			US	4077500 A	07-03-1978
GB 1572153	A	23-07-1980	NONE		
US 4024936	A	24-05-1977	NONE		
US 5050710	A	24-09-1991	WO	9115686 A1	17-10-1991
WO 8303124	A	15-09-1983	CA	1188637 A1	11-06-1985
			EP	0102950 A1	21-03-1984
			IT	1193696 B	21-07-1988
			JP	59500326 T	01-03-1984