



- (51) International Patent Classification:  
*G06T 19/00* (2011.01)    *G06T 17/00* (2006.01)
- (21) International Application Number:  
PCT/US2013/042517
- (22) International Filing Date:  
23 May 2013 (23.05.2013)
- (25) Filing Language: English
- (26) Publication Language: English
- (30) Priority Data:  
61/650,983    23 May 2012 (23.05.2012)    US  
61/735,951    11 December 2012 (11.12.2012)    US  
13/774,958    22 February 2013 (22.02.2013)    US
- (71) Applicant: **1-800 CONTACTS, INC.** [US/US]; 66 E. Wadsworth Park Dr., Draper, Utah 84020 (US).
- (72) Inventors: **GRAVOIS, Adam**; 5109 Avenue F, Austin, Texas 78751 (US). **ENGLE, Ryan**; 1520 Tranquility Lane, Pflugerville, Texas 78660 (US).
- (74) Agent: **PRATT, Bryan G.**; Holland & Hart LLP, P.O. Box 11583, 222 S. Main Street, Suite 2200, Salt Lake City, Utah 84110 (US).

- (81) Designated States (unless otherwise indicated, for every kind of national protection available): AE, AG, AL, AM, AO, AT, AU, AZ, BA, BB, BG, BH, BN, BR, BW, BY, BZ, CA, CH, CL, CN, CO, CR, CU, CZ, DE, DK, DM, DO, DZ, EC, EE, EG, ES, FI, GB, GD, GE, GH, GM, GT, HN, HR, HU, ID, IL, IN, IS, JP, KE, KG, KM, KN, KP, KR, KZ, LA, LC, LK, LR, LS, LT, LU, LY, MA, MD, ME, MG, MK, MN, MW, MX, MY, MZ, NA, NG, NI, NO, NZ, OM, PA, PE, PG, PH, PL, PT, QA, RO, RS, RU, RW, SC, SD, SE, SG, SK, SL, SM, ST, SV, SY, TH, TJ, TM, TN, TR, TT, TZ, UA, UG, US, UZ, VC, VN, ZA, ZM, ZW.
- (84) Designated States (unless otherwise indicated, for every kind of regional protection available): ARIPO (BW, GH, GM, KE, LR, LS, MW, MZ, NA, RW, SD, SL, SZ, TZ, UG, ZM, ZW), Eurasian (AM, AZ, BY, KG, KZ, RU, TJ, TM), European (AL, AT, BE, BG, CH, CY, CZ, DE, DK, EE, ES, FI, FR, GB, GR, HR, HU, IE, IS, IT, LT, LU, LV, MC, MK, MT, NL, NO, PL, PT, RO, RS, SE, SI, SK, SM, TR), OAPI (BF, BJ, CF, CG, CI, CM, GA, GN, GQ, GW, ML, MR, NE, SN, TD, TG).

**Declarations under Rule 4.17:**

- as to applicant's entitlement to apply for and be granted a patent (Rule 4.17(ii))

[Continued on next page]

(54) Title: SYSTEMS AND METHODS FOR RENDERING VIRTUAL TRY-ON PRODUCTS

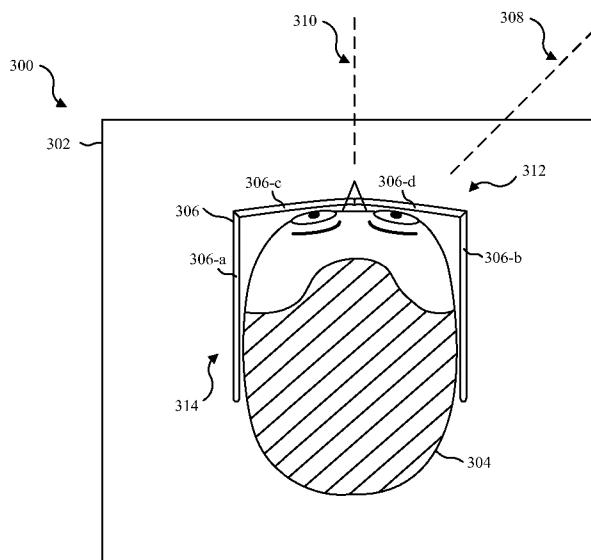


FIG. 3

(57) Abstract: A computer-implemented method for rendering virtual try-on products is described. A first render viewpoint is selected of a virtual 3-D space that includes a 3-D model of at least a portion of a user generated from an image of the user and a 3-D polygon mesh of an object. Polygons of the 3-D polygon mesh are designated as backwards-facing polygons and front-facing polygon in relation to the first render viewpoint. A shadow texture map of the object is applied to the 3-D model of the user. A transparency texture map of the object is applied to the backwards-facing polygon of the 3-D polygon mesh of the object. A first color texture map of the object is applied to the result of the application of the transparency texture map to the backwards-facing polygon. The virtual 3-D space is rendered at the first render viewpoint.



- *as to the applicant's entitlement to claim the priority of the earlier application (Rule 4.17(iii))* **Published:**  
— *with international search report (Art. 21(3))*

## SYSTEMS AND METHODS FOR RENDERING VIRTUAL TRY-ON PRODUCTS

### RELATED APPLICATIONS

5           [0001]    This application claims priority to U.S. Provisional Application No. 61/650,983, entitled SYSTEMS AND METHODS TO VIRTUALLY TRY-ON PRODUCTS, filed on May 23, 2012; U.S. Application No. 61/735,951, entitled SYSTEMS AND METHODS TO VIRTUALLY TRY-ON PRODUCTS, filed on December 11, 2012; and U.S. Application No. 13/774,958, entitled SYSTEMS AND  
10 METHODS FOR RENDERING VIRTUAL TRY-ON PRODUCTS, filed on February 22, 2013, all of which are incorporated herein in their entirety by this reference.

### BACKGROUND

          [0002]    The use of computer systems and computer-related technologies continues to increase at a rapid pace. This increased use of computer systems has influenced the advances made to computer-related technologies. Indeed, computer  
15 systems have increasingly become an integral part of the business world and the activities of individual consumers. For example, computers have opened up an entire industry of internet shopping. In many ways, online shopping has changed the way consumers purchase products. However, in some cases, consumers may avoid shop-  
20 ping online. For example, it may be difficult for a consumer to know if they will look good in and/or with a product without seeing themselves in and/or with the product. In many cases, this challenge may deter a consumer from purchasing a product online. Therefore, rendering three-dimensional (3-D) scenes to improve the online shopping experience may be desirable.

### 25                   DISCLOSURE OF THE INVENTION

          [0003]    According to at least one embodiment, a computer-implemented method for virtual rendering virtual try-on products is described. A first render viewpoint of a virtual three-dimensional (3-D) space may be selected that includes a 3-D model of at least a portion of a user generated from an image of the user and a  
30 3-D polygon mesh of an object. Polygons of the 3-D polygon mesh may be desig-

nated as backwards-facing polygons and front-facing polygons in relation to the first render viewpoint. A shadow texture map of the object may be applied to the 3-D model of the user. A transparency texture map of the object may be applied to a backwards-facing polygon of the 3-D polygon mesh of the object. A first color texture map of the object may be applied to the result of the application of the transparency texture map to the backwards-facing polygon. The virtual 3-D space may be rendered at the first render viewpoint. The transparency texture map of the object may be applied to a front-facing polygon of the 3-D polygon mesh of the object. The first color texture map of the object may be applied to the result of the application of the transparency texture map to the front-facing polygon. The virtual 3-D space may be rendered at the first render viewpoint

[0004] In some embodiments, at least a portion of the 3-D polygon mesh of the object may be placed within a predetermined distance of at least one point on the 3-D model of the user.

[0005] In some embodiments, a shadow value of the object may be detected from a scan of the object. In some cases, a shadow texture map may be created from the detected shadow value. A 2-D coordinate of the shadow texture map may be mapped to a point on the 3-D model of the user and a value of the point on the 3-D model of the user may be multiplied by the shadow value.

[0006] In some embodiments, a transparency value of the object may be detected from a scan of the object. In some cases, a transparency texture map may be created from the detected transparency value. A 2-D coordinate of the transparency texture map may be mapped to a point on the 3-D model of the user and the 3-D polygon mesh of the object. A value of the point on the 3-D model of the user and the 3-D polygon mesh of the object may be multiplied by the transparency value.

[0007] In some embodiments, a first scanning angle of a scan of an object may be selected. The first scanning angle may correspond to the first render viewpoint. In some cases, a first color value of the object may be detected at the first scanning angle. A first color texture map may be created from the detected color value. A 2-D coordinate of the first color texture map may be mapped to a point on the 3-D model of the user and the 3-D polygon mesh of the object. The resultant value of multiplying the point on the 3-D model of the user and the 3-D polygon

mesh of the object by the transparency value may be multiplied by the first color value.

[0008] In some embodiments, a second render viewpoint of the virtual 3-D space may be selected. In some cases, a second scanning angle of a scan of an object may be selected. The second scanning angle may correspond to the second render viewpoint. A second color value of the object at the second scanning angle may be detected. A second color texture map from the detected second color value may be created. In some cases, the shadow texture map of the object may be applied to the 3-D model of the user at the second render viewpoint. The transparency texture map of the object may be applied to the backwards-facing polygon of the 3-D polygon mesh of the object at the second render viewpoint. The second color texture map of the object may be applied to the result of the application of the transparency texture map to the backwards-facing polygon at the second render viewpoint. The transparency texture map of the object may be applied to the front-facing polygon of the 3-D polygon mesh of the object at the second render viewpoint. The second color texture map of the object may be applied to the result of the application of the transparency texture map to the front-facing polygon at the second render viewpoint. The virtual 3-D space may be rendered at the second render viewpoint.

[0009] In some embodiments, the 3-D polygon mesh of the object may be divided into two or more portions. An order to the portions of the divided 3-D polygon mesh of the object may be determined from furthest portion to closest portion relative to the determined render viewpoint of the virtual 3-D space.

[0010] In some cases, the present system may determine whether a portion of the 3-D polygon mesh of the object is visible in relation to the 3-D model of the user based on the determined render viewpoint. The 3-D polygon mesh of the object may be rendered from the furthest portion to the closest portion based on a visible portion of the 3-D polygon mesh of the object.

[0011] A computing device configured to scale a three-dimensional (3-D) model is also described. The device may include a processor and memory in electronic communication with the processor. The memory may store instructions that are executable by the processor to select a first render viewpoint of a virtual 3-D space. The virtual 3-D space may include a 3-D model of at least a portion of a user

generated from an image of the user and a 3-D polygon mesh of an object. Additionally, the instructions may be executable by the processor to designate a first polygon of the 3-D polygon mesh of the object as a backwards-facing polygon in relation to the first render viewpoint, designate a second polygon of the 3-D polygon mesh of the object as a front-facing polygon in relation to the first render viewpoint, and apply a shadow texture map of the object to the 3-D model of the user. Additionally, the instructions may be executable by the process to apply a transparency texture map of the object to the backwards-facing polygon of the 3-D polygon mesh of the object, apply a first color texture map of the object to the result of the application of the transparency texture map to the backwards-facing polygon, and render the virtual 3-D space at the first render viewpoint.

[0012] A computer-program product to scale a three-dimensional (3-D) model is also described. The computer-program product may include a non-transitory computer-readable medium that stores instructions. The instructions may be executable by a processor to select a first render viewpoint of a virtual 3-D space. The virtual 3-D space comprises a 3-D model of at least a portion of a user generated from an image of the user and a 3-D polygon mesh of an object. Additionally, the instructions may be executable by the processor to designate a first polygon of the 3-D polygon mesh of the object as a backwards-facing polygon in relation to the first render viewpoint, designate a second polygon of the 3-D polygon mesh of the object as a front-facing polygon in relation to the first render viewpoint, and apply a shadow texture map of the object to the 3-D model of the user. Additionally, the instructions may be executable by a processor to apply a transparency texture map of the object to the backwards-facing polygon of the 3-D polygon mesh of the object, apply a first color texture map of the object to the result of the application of the transparency texture map to the backwards-facing polygon, and apply the transparency texture map of the object to the front-facing polygon of the 3-D polygon mesh of the object. Additionally, the instructions may be executable by the processor to apply the first color texture map of the object to the result of the application of the transparency texture map to the front-facing polygon and render the virtual 3-D space at the first render viewpoint.

[0013] Features from any of the above-mentioned embodiments may be used in combination with one another in accordance with the general principles described herein. These and other embodiments, features, and advantages will be more fully understood upon reading the following detailed description in conjunction with the accompanying drawings and claims.

### BRIEF DESCRIPTION OF THE DRAWINGS

[0014] The accompanying drawings illustrate a number of exemplary embodiments and are a part of the specification. Together with the following description, these drawings demonstrate and explain various principles of the instant disclosure.

[0015] FIG. 1 is a block diagram illustrating one embodiment of an environment in which the present systems and methods may be implemented;

[0016] FIG. 2 is a block diagram illustrating another embodiment of an environment in which the present systems and methods may be implemented;

[0017] FIG. 3 illustrates an example arrangement of a virtual 3-D space;

[0018] FIG. 4 is a block diagram illustrating one example of a rendering module;

[0019] FIG. 5 illustrates another example arrangement of a virtual 3-D space;

[0020] FIG. 6 illustrates another example arrangement of a virtual 3-D space;

[0021] FIG. 7 is a flow diagram illustrating one embodiment of a method to render a virtual 3-D space;

[0022] FIG. 8 is a flow diagram illustrating one embodiment of a method to create a shadow texture map;

[0023] FIG. 9 is a flow diagram illustrating one embodiment of a method to create a transparency texture map;

[0024] FIG. 10 is a flow diagram illustrating one embodiment of a method to create a color texture map;

[0025] FIG. 11 is a flow diagram illustrating another embodiment of a method to render the virtual 3-D space;

[0026] FIG. 12 is a flow diagram illustrating one embodiment of a method to apply a blurring effect to a rendered depiction of the object; and

[0027] FIG. 13 depicts a block diagram of a computer system suitable for implementing the present systems and methods.

5 [0028] While the embodiments described herein are susceptible to various modifications and alternative forms, specific embodiments have been shown by way of example in the drawings and will be described in detail herein. However, the exemplary embodiments described herein are not intended to be limited to the particular forms disclosed. Rather, the instant disclosure covers all modifications, equivalents,  
10 and alternatives falling within the scope of the appended claims.

#### **BEST MODE(S) FOR CARRYING OUT THE INVENTION**

[0029] The systems and methods described herein relate to the virtually trying-on of products. Three-dimensional (3-D) computer graphics are graphics that use a 3-D representation of geometric data that is stored in the computer for the purposes of performing calculations and rendering 2-D images. Such images may be  
15 stored for viewing later or displayed in real-time. A 3-D space may include a mathematical representation of a 3-D surface of an object. A 3-D model may be contained within a graphical data file. A 3-D model may represent a 3-D object using a collection of points in 3-D space, connected by various geometric entities such as  
20 triangles, lines, curved surfaces, etc. Being a collection of data (points and other information), 3-D models may be created by hand, algorithmically (procedural modeling), or scanned such as with a laser scanner. A 3-D model may be displayed visually as a two-dimensional image through a process called 3-D rendering, or used in non-graphical computer simulations and calculations. In some cases, the 3-D model  
25 may be physically created using a 3-D printing device.

[0030] A virtual 3-D space may include a 3-D model of a user's face and a polygon mesh of a pair of glasses. The 3-D polygon mesh of the pair of glasses may be placed on the user to create a 3-D virtual depiction of the user wearing a properly scaled pair of glasses. This 3-D scene may then be rendered into a two-dimensional  
30 (2-D) image to provide the user a virtual depiction of the user wearing a certain style of glasses. Although many of the examples used herein describe the virtual try-on of



glasses, it is understood that the systems and methods described herein may be used to virtually try-on a wide variety of products. Examples of such products may include glasses, clothing, footwear, jewelry, accessories, hair styles, etc.

[0031] FIG. 1 is a block diagram illustrating one embodiment of an environment 100 in which the present systems and methods may be implemented. In some embodiments, the systems and methods described herein may be performed on a single device (e.g., device 102). For example, a rendering module 104 may be located on the device 102. Examples of devices 102 include mobile devices, smart phones, personal computing devices, computers, servers, etc.

[0032] In some configurations, a device 102 may include a rendering module 104, a camera 106, and a display 108. In one example, the device 102 may be coupled to a database 110. In one embodiment, the database 110 may be internal to the device 102. In another embodiment, the database 110 may be external to the device 102. In some configurations, the database 110 may include polygon model data 112 and texture map data 114.

[0033] In one embodiment, the rendering module 104 may enable a user to virtually try-on a pair of glasses. In some configurations, the rendering module 104 may obtain multiple images of a user. For example, the rendering module 104 may capture multiple images of a user via the camera 106. For instance, the rendering module 104 may capture a video (e.g., a 5 second video) via the camera 106. In some configurations, the rendering module 104 may use polygon model data 112 and texture map data 114 to generate a 3-D representation of a user. For example, the polygon model data 112 may include vertex coordinates of a polygon model of the user's head. In some embodiments, the rendering module 104 may use color information from the pixels of multiple images of the user to create a texture map of the user. In some configurations, the rendering module 104 may generate and/or obtain a 3-D representation of a product. For example, the polygon model data 112 and texture map data 114 may include a 3-D model of a pair of glasses. In some embodiments, the polygon model data 112 may include a polygon model of an object. In some configurations, the texture map data 114 may define a visual aspect (e.g., pixel information) of the 3-D model of the object such as color, texture, shadow, or transparency.

[0034] In some configurations, the rendering module 104 may generate a virtual try-on image by rendering a virtual 3-D space that contains a 3-D model of a user and a 3-D model of a product. In one example, the virtual try-on image may illustrate the user with a rendered version of the product. In some configurations, the rendering module 104 may output the virtual try-on image to the display 108 to be displayed to the user.

[0035] FIG. 2 is a block diagram illustrating another embodiment of an environment 200 in which the present systems and methods may be implemented. In some embodiments, a device 102-a may communicate with a server 206 via a network 204. Example of networks 204 include, local area networks (LAN), wide area networks (WAN), virtual private networks (VPN), wireless networks (using 802.11, for example), cellular networks (using 3G and/or LTE, for example), etc. In some configurations, the network 204 may include the internet. In some configurations, the device 102-a may be one example of the device 102 illustrated in FIG. 1. For example, the device 102-a may include the camera 106, the display 108, and an application 202. It is noted that in some embodiments, the device 102-a may not include a rendering module 104. In some embodiments, both a device 102-a and a server 206 may include a rendering module 104 where at least a portion of the functions of the rendering module 104 are performed separately and/or concurrently on both the device 102-a and the server 206.

[0036] In some embodiments, the server 206 may include the rendering module 104 and may be coupled to the database 110. For example, the rendering module 104 may access the polygon model data 112 and the texture map data 114 in the database 110 via the server 206. The database 110 may be internal or external to the server 206.

[0037] In some configurations, the application 202 may capture multiple images via the camera 106. For example, the application 202 may use the camera 106 to capture a video. Upon capturing the multiple images, the application 202 may process the multiple images to generate result data. In some embodiments, the application 202 may transmit the multiple images to the server 206. Additionally or alternatively, the application 202 may transmit to the server 206 the result data or at least one file associated with the result data.

[0038] In some configurations, the rendering module 104 may process multiple images of a user to generate a 3-D model of the user. In some configurations, the rendering module 104 may process a scan of an object to create a 3-D polygon model of the object. The rendering module 104 may render a 3-D space that includes the 3-D model of the user and the 3-D polygon model of the object to render a virtual try-on 2-D image of the object and the user. The application 202 may output the rendered virtual try-on image to the display 208 to be displayed to the user.

[0039] FIG. 3 illustrates an example arrangement 300 of a virtual 3-D space 302. As depicted, the 3-D space 302 of the example arrangement 300 may include a 3-D model of a user's head 304 and a 3-D model of a pair of glasses 306. The example arrangement 300 may also include a first render viewpoint 308 and a second render viewpoint 310. In some embodiments, the first and second render viewpoints 308 and 310 may correspond to first and second scanning angles (not shown). In some embodiments, the first and second scanning angle may be associated with scanning of a user's head to create the 3-D model of the user's head 304. Additionally or alternatively, the first and second scanning angle may be associated with scanning of a pair of glasses to create the 3-D model of the glasses 306.

[0040] In some embodiments, the 3-D model of the user's head 304 may include a polygon model of the user's head, which may be stored in the database 110 as polygon data 112, and at least one texture map, which may be stored in the database 110 as texture map data 114. In some embodiments, the 3-D model of the glasses 306 may include a polygon model of the glasses, which may be stored in the database 110 as polygon data 112, and at least one texture map, which may be stored in the database 110 as texture map data 114. In some embodiments, the polygon model of the glasses may include front-facing polygons 312 and backwards-facing polygons 314. For example, those polygons that face the first rendering viewing angle 308 may be designated as front-facing polygons 312 and those polygons that do not face the first rendering viewing angle 308 may be designated as backwards-facing polygons 314.

[0041] In some embodiments, the 3-D model of the glasses 306 may be divided into multiple parts. As depicted in FIG. 3, the 3-D model of the glasses 306 may be divided into a left arm 306-a, a right arm 306-b, a left lens and frame 306-c,

and a right lens and frame 306-d. In some embodiments, the 3-D space 302 may be rendered based on the position of the parts 306-a, 306-b, 306-c, and 306-d of the 3-D model of the glasses 306 in the 3-D space 302 relative to a render viewpoint. For example, the rendering module 104 may render the 3-D space 302 in order of furthest to closest parts of the 3-D model of the glasses 306 in relation to the first render viewpoint 308. In other words, the rendering module 104 may render first the left arm 306-a (*i.e.*, the farthest part relative to the first render viewpoint 308), the left lens and frame 306-c next, then the right lens and frame 306-d, and finally the right arm 306-b (*i.e.*, the closest part relative to the first render viewpoint 308).

[0042] In some embodiments, the rendering module 104 may determine whether a portion of the 3-D model of the glasses 306 is visible in relation to a render of the 3-D space 302 at a particular render viewpoint. For example, as depicted in FIG. 3, the rendering module 104 may determine that only a portion of the left arm 306-a is visible in relation to the first render viewpoint 308. Thus, the rendering module 104 may render only that portion of the left arm 306-a that is visible in a render of the 3-D space 302 at the first render viewpoint 308. Rendering of the 3-D space 302 is discussed in further detail below in relation to the description of FIGS. 4, 5, and 6.

[0043] FIG. 4 is a block diagram illustrating one example of a rendering module 104-a. The rendering module 104-a may be one example of the rendering module 104 illustrated in FIGS. 1 or 2.

[0044] In some embodiments, the rendering module 104-a may include a scanning module 402, a polygon mesh module 404, a texture mapping module 406, a hidden surface detection module 408, a blurring module 410, and an edge detection module 412. In one embodiment, the rendering module 104-a may be configured to select a first render viewpoint of a virtual 3-D space. A render viewpoint may be the point of view of a virtual 3-D space, and may be referred to as the view reference point (VRP). In other words, the render viewpoint may be the view a user would see were a user to gaze at a depiction of the 3-D space or 3-D scene from a certain point of view. Thus, theoretically an infinite number of render viewpoints are possible that involve the orientation of the 3-D space relative to the position of a point of view of the 3-D space. The virtual 3-D space may include a 3-D model of at least a

portion of a user generated from an image of the user. For example, the virtual 3-D space may include a 3-D model of a user's head that is generated from one or more images of the user's head. The virtual 3-D space may also include a 3-D polygon mesh of an object. For instance, the virtual 3-D space may include a 3-D polygon mesh of a pair of glasses. The 3-D polygon mesh may include a collection of vertices, edges and surfaces that define the shape of a polyhedral object in 3-D computer graphics and modeling. The surface of the 3-D polygon mesh may include triangles, quadrilaterals, or other convex polygons. In some configurations, the rendering module 104-a may be configured to render the virtual 3-D space at a selected render viewpoint such as the first render viewpoint. In some embodiments, the rendering module 104-a may be configured to place or position at least a portion of the 3-D polygon mesh of the object within a predetermined distance of at least one point on the 3-D model of the user. For instance, the 3-D polygon mesh of the object may include a 3-D polygon mesh of a pair of glasses. The 3-D polygon mesh of the glasses may be placed within a predetermined distance of a 3-D model of the user's head. For example, a 3-D polygon mesh of a pair of glasses may be placed within a predetermined distance of a 3-D model of a user's head so as to make the 3-D polygon mesh of the glasses appear to be worn on the head of a 3-D model of the user.

[0045] In some embodiments, the rendering module 104-a may be configured to select a second render viewpoint of the virtual 3-D space. For example, the rendering module 104-a may select a first render viewpoint that depicts a side-view, or profile of a 3-D model of a user's head wearing a 3-D model of a pair of glasses. The rendering module 104-a may select a second render viewpoint that depicts a frontal, head-on view of the 3-D model of the user's head wearing a 3-D model of the pair of glasses. In some configurations, the rendering module 104-a may be configured to render the virtual 3-D space at the first and second render viewpoints. Thus, the rendering module 104-a may render a side-view of the 3-D model of the user wearing the 3-D model of the pair of glasses (*i.e.*, the first render viewpoint), and may render a head-on view where the 3-D depiction of the user's face is directly facing in the direction of the rendering of the 3-D space.

[0046] In some embodiments, the scanning module 402 may be configured to detect a shadow value of an object from a scan of the object. A shadow value of

an object may include information about a shadow cast by the object captured from the scan of the object. For example, a pair of glasses may be scanned by a laser. From this laser scan the scanning module 402 may detect one or more values associated with a shadow cast by the object. For example, the scanning module 402 may  
5 detect a level of shadow cast by certain parts of a pair of glasses. The scanning module 402 may determine that the degree of shadow cast by an opaque segment of the pair of glasses is greater than the degree of shadow cast by the lens. Furthermore, the scanning module 402 may determine that directly behind the center of an arm of the glasses running the length of the arm may cast a higher degree of shadow  
10 than the edges of the arm where a shadow may gradually dissipate.

[0047] In some configurations, the scanning module 402 may be configured to detect a transparency value of an object from a scan of the object. A transparency value of an object may include information about the transparent nature of a portion of the object captured from the scan of the object. For example, the scanning mod-  
15 ule 402 may determine that a lens in a pair of glasses has a transparency value of 50%, meaning that 50% of the light that hits the surface of the lens is transferred through the lens and the other 50% of the light is reflected off the surface of the lens. The scanning module 402 may detect the 50% transparency as one transparency value associated with the scan of the glasses. Additionally, the scanning module  
20 402 may determine that a portion of the frame of the pair of glasses has a transparency value of 0%, meaning that 100% of the light that hits the surface of the frame is reflected. The scanning module 402 may detect the 0% transparency as another transparency value associated with the scan of the glasses.

[0048] In one embodiment, the scanning module 402 may be configured to  
25 select a first scanning angle of a scan of an object. The first scanning angle may correspond to the first render viewpoint. Thus, scanning a pair of glasses at 30 degrees left of center of a pair of glasses may correspond to an image of a user taken at 30 degrees left of a center or head-on view of the user. In some embodiments, the scanning module 402 may be configured to detect a first color value from a scan of  
30 an object at the first scanning angle. A color value of an object may include information about a visual aspect of the object captured from the scan of the object. For example, the scanning module 402 may scan a pair glasses with shiny red frames.

Thus, the scanning module 402 may detect the red color of the frames as one color value associated with the scan of the glasses. Additionally or alternatively, the scanning module 402 may detect other visual aspects associated with the scanned frames such as the reflectivity of the frames and save the reflectivity as a value associated with the surface of the frames. In some configurations, the scanning module 402 may be configured to select a second scanning angle of a scan of an object. The second scanning angle may correspond to the second render viewpoint. The scanning module 402 may be configured to detect a second color value of an object at the second scanning angle. Thus, scanning a pair of glasses at 40 degrees left of the center or head-on view of a pair of glasses may correspond to a second image of a user taken at 40 degrees left of the center or head-on view of the user. Similar to the scan at the first angle, the scanning module 402 may detect visual aspects associated with the frames scanned at the second scanning angle such as the color and reflectivity of the frames and save the color and reflectivity as values associated with the surface of the frames

**[0049]** In some embodiments, the hidden surface detection module 408 may be configured to determine whether a portion of the 3-D polygon mesh of the object is visible in relation to the 3-D model of the user based on the determined render viewpoint. The rendering of the 3-D space may include rendering the scene of the virtual 3-D space based on a visible portion of the 3-D polygon mesh of the object. In other words, rendering the 3-D space when the render viewpoint depicts the left side of the 3-D model of the user's head, portions of the 3-D polygon mesh of the object that are positioned to the right side of the 3-D model of the user's head would not be visible in the render. In other words, in some embodiments, the texture mapping module 406 does not apply one or more elements of the texture maps (i.e., shadow texture map, transparency texture map, and/or color texture map) to those portions of the 3-D polygon mesh of the object that would not be visible in the render due to the positioning of the 3-D model of the user relative to the selected render viewpoint. Thus, in some embodiments, the rendering module 402-a renders those portions of the 3-D polygon mesh of the object that are visible based on the determined render viewpoint.

[0050] In some embodiments, the polygon mesh module 404 may be configured to designate at least one polygon of the 3-D polygon mesh of the object as a backwards-facing polygon in relation to a render viewpoint. In some configurations, the polygon mesh module 404 may be configured to designate at least one polygon of the 3-D polygon mesh of the object as a front-facing polygon in relation to a render viewpoint. As explained above, the 3-D polygon mesh of the object may include a collection of vertices, edges and surfaces that define the shape of a polyhedral version of the object in a virtual 3-D space. Thus, the surface of a 3-D polygon mesh of a pair of glasses may include triangles, quadrilaterals, or other convex polygons. As with all 3-D objects, the surface of the 3-D polygon mesh of the pair of glasses may include polygons on six different surfaces. For example, the left arm of a pair of glasses may include top and bottom surfaces, left and right surfaces, and front and back surfaces in relation to a given render viewpoint. With a render viewpoint positioned to view the left side of a 3-D model of a user's head, the polygons of the outside surface of the left arm of a 3-D model of a pair of glasses worn on the 3-D model of the user's head would face the render viewpoint. The inside surface, the polygons facing the left side of the 3-D model of the user's face, would face away from the render viewpoint. Thus, with a render viewpoint positioned to view the left side of a 3-D model of a user's head, the polygon mesh module 404 may designate the polygons of the outside surface of the left arm of a 3-D model of a pair of glasses worn on the 3-D model of the user's head as front-facing polygons. Similarly, the polygon mesh module 404 may designate the inside polygons facing the left side of the 3-D model of the user's face as backwards-facing polygons. As explained above with reference to FIG. 3, in one embodiment, the polygon mesh module 404 may be configured to divide 3-D polygon mesh of an object into two or more portions. For example, the polygon mesh module 404 may be configured to divide a 3-D polygon mesh of a pair of glasses into two or more parts. For instance, the polygon mesh module 404 may divide the 3-D polygon mesh of the pair of glasses into a first part that includes the left arm, a second part that includes the right arm, a third part that includes the left lens and frame, and a fourth part that includes the right lens and frame.



[0051] In some embodiments, the rendering module 104-a may be configured to determine an order to multiple portions of a divided 3-D polygon mesh of an object from the farthest portion to the closest portion relative to a determined render viewpoint of the virtual 3-D space. For example, with a render viewpoint of a left profile of a 3-D model of a user's head wearing a 3-D model of a pair of glasses, the render module 104-a may determine the polygon mesh of the left arm of the pair of glasses to be the closest portion of the 3-D polygon mesh of the glasses, followed by the left lens and frame and the right lens and frame. Thus, the render module 104-a may determine that the polygon mesh of the right arm of the pair of glasses to be the farthest portion of the 3-D polygon mesh of the glasses. Upon determining the order of the parts of the 3-D polygon mesh of an object, in some embodiments, the rendering module 104-a may be configured to render the 3-D polygon mesh of the object from the furthest portion to the closest portion.

[0052] FIG. 5 illustrates another example arrangement of a virtual 3-D space 500. In particular, the illustrated 3-D space 500 includes a 3-D model of a user 502 and a depiction of a shadow texture map 504. In some embodiments, the texture mapping module 406 may be configured to create the shadow texture map 504 from a shadow value. As depicted in FIG. 5, in some embodiments, the texture mapping module 406 may be configured to map a 2-D coordinate 506 of the shadow texture map 504 to a point 508 on the 3-D model of the user 502. For example, the texture mapping module 406 may convert a shadow value detected from a scan of an object by the scanning module 402 into a 2-D image and store the shadow texture map 2-D image as texture map data in the database 110. The point 508 on the 3-D model of the user 502 may include information associated with a visual aspect of the 3-D model of the user 502 such as color information. Thus, the texture mapping module 406 may be configured to multiply a value of the point 508 on the 3-D model of the user by the shadow value at the 2-D coordinate 506 of the shadow texture map 504 resulting in the point 508 on the 3-D model including the original information associated with the point 508 and a value associated with the shadow texture map 504 such as the lightness or darkness of the shadow at that point 506 on the shadow texture map 504.

[0053] Referring again to FIG. 4, in some embodiments, the texture mapping module 406 may be configured to create a transparency texture map from a detected transparency value. For example, the texture mapping module 406 may convert a transparency value detected from a scan of an object by the scanning module 402 into a transparency texture map 2-D image and store the 2-D image as texture map data 114 in the database 110. As explained above, the transparency texture map may include information regarding the transparent aspects associated with the scanned object such as a fully- or semi-transparent lens, a semi-transparent portion of a frame, and/or an opaque portion of a frame or lens. As with the shadow texture map, the texture mapping module 406 may convert a transparency value detected from a scan of an object by the scanning module 402 into a 2-D image and save this 2-D image as the transparency texture map. In some configurations, the texture mapping module 406 may be configured to map a 2-D coordinate of the transparency texture map to a point on the 3-D model of the user and a 3-D polygon mesh of the object. In order to create the look of transparency, the texture mapping module 406 may map a point of the 3-D model of the user that is visible through a transparent portion of the 3-D model of the object to a point on the 3-D polygon mesh of the object. In other words, data associated with the visual aspects of a portion of the 3-D model of the user visible behind the lens on a 3-D polygon of a pair of glasses may be merged with transparency data associated with the lens to render the effect of seeing the portion of the user through the lens. In some embodiments, the texture mapping module 406 may be configured to multiply the value of the point on the 3-D model of the user by the transparency value.

[0054] In some embodiments, the texture mapping module 406 may be configured to create a first color texture map from a detected first color value from a scan of the object at a first scanning angle. In some embodiments, the texture mapping module 406 may be configured to create a second color texture map from the detected second color value from a scan of the object at a second scanning angle. For example, the texture mapping module 406 may convert a color value detected from a scan of an object by the scanning module 402 into a 2-D image and store the color texture map 2-D image as texture map data in the database 110. In some embodiments, the texture map data 114 of the polygon mesh of the object may contain a

color texture map for every angle at which the object is scanned. For example, with the user holding his or her head vertically, if the user's head is scanned in a pan around the user's head from -70 degrees to the side of the head-on view of the user's face to +70 degrees to the side of the head-on view of the user's face in 10 degree intervals, then the scan would include 15 reference viewpoints of the user's head, including a straight, head-on view of the user's face at 0 degrees. The scanning module 402 may then scan a pair of glasses from -70 degrees to +70 degrees to create 15 corresponding reference viewpoints of the glasses. Thus, in some embodiments, the texture mapping module 406 may create 15 color texture maps, one for each of the 15 corresponding reference viewpoints of the glasses. However, in some embodiments, the texture mapping module 406 may create a single shadow texture map and a single transparency map for the 15 corresponding reference viewpoints of the glasses. In some embodiments, the texture mapping module 406 may be configured to map a 2-D coordinate of the first color texture map to a point on the 3-D model of the user and a point on a 3-D polygon mesh of the object, which may be the same points associated with the application of the transparency texture map. Thus, in some configurations the texture mapping module 406 may be configured to multiply the result of multiplying the transparency texture map and the point on the 3-D model of the user and the 3-D polygon mesh of the object by the first color value. In other words, the texture mapping module 406 may first apply the transparency of the lens on a 3-D polygon mesh of a pair of glasses (*i.e.*, merging the visible portion of the user with the transparent portion of the glasses) and then apply the color of the lens to that result.

[0055] In some embodiments, the texture mapping module 406 may be configured to apply a shadow texture map of an object to a 3-D model of a user. As explained above with reference to FIG. 5, the rendering module 104-a may position a 3-D polygon mesh of a pair of glasses on a 3-D model of a user's head in a manner that depicts the user wearing a pair of glasses. The shadow texture map of the 3-D polygon mesh of a pair of glasses may be applied to the face of a 3-D model of a user's head. Thus, the application of a shadow texture map may be based on the placement of the 3-D polygon mesh of the object in relation to the 3-D model of the user.

[0056] In some configurations the texture mapping module 406 may be configured to apply a transparency texture map of the object to backwards-facing polygons of the 3-D polygon mesh of the object. Applying the transparency values of backwards-facing triangles before front-facing triangles allows portions of the 3-D polygon mesh that would be visible through a transparent section of the mesh (*i.e.*, the lenses) to be rendered before other portions of the 3-D polygon mesh that would block portions of the 3-D polygon mesh of the object and 3-D model of the user that would normally be viewable through the transparent section. For example, with a render viewpoint from the left of the user, a portion of the back of the frames of the 3-D polygon mesh of a pair of glasses may be visible through the lens. Rendering that portion of the back of the frames before the front portion allows that back portion to be visible through the lens following a rendering of the 3-D space.

[0057] In some embodiments, the texture mapping module 406 may be configured to apply a first color texture map of the object to the result of the application of the transparency texture map to the backwards-facing polygons. In some embodiments, the texture mapping module 406 may be configured to apply a transparency texture map of the object to front-facing polygons of the 3-D polygon mesh of an object. The texture mapping module 406 may be configured to apply a first color texture map of the object to the result of the application of the transparency texture mapped to the front-facing polygons. The rendering module 104-a may then render the 3-D space at the first render viewing angle. For example, the backward-facing polygons of the lens may be applied to combine the value of a pixel of the 3-D model of a user with the value of the lens directly in front of that pixel of the 3-D model of the user. Combining the pixel with the transparency value gives renders the lens as being transparent so that the portion of the user behind the lens is seen in the render. Having applied the transparency value to the 3-D model of the user, the texture mapping module 406 may apply the color texture map to the same point. In other words, if the lens is a brown lens, the color texture map may include color information of the brown lens. Thus, the texture mapping module 406 may apply the brown color to the same point on the 3-D model of the user where the transparency texture map was applied. The process may then be repeated for the same point on the 3-D model of the user with the front-facing polygons of the 3-D polygon mesh of

the object, resulting in a rendered brown transparent lens through which the 3-D model of the user's eye may be seen once rendering completes.

[0058] In some embodiments, the text, the texture mapping module 406 may be configured to apply the shadow texture map of the object to a 3-D model of the user at the second render viewpoint. The texture mapping module 406 may be configured to apply the transparency texture map of the object to backwards-facing polygons of the 3-D polygon mesh of the object at the second render viewpoint and then apply the second color texture map to the 3-D polygon mesh of the object as a result of the application of the transparency texture map to the backwards-facing polygons at the second render viewpoint. In some embodiments, the texture mapping module 406 may be configured to apply the transparency texture map of an object to front-facing polygons of the 3-D polygon mesh of the object at the second render viewpoint and then apply the second color texture map of the object to the result of the application of the transparency texture mapped to the front-facing polygons at the second render viewing angle. The rendering module 104-a may then render the 3-D space at the second render viewing angle.

[0059] In some embodiments, the blurring module 410 may be configured to determine a first level and a second level of blur accuracy. For example, applying a blurring effect to a portion of the rendered 3-D space with a relatively high accuracy may require a correspondingly high amount of processing time. Attempting to apply the blurring effect with relatively high accuracy while the render viewpoint of the 3-D space is modified may introduce a lag in the rendering of the 3-D space. On the other hand, applying a blurring effect to a portion of the rendered 3-D space with a relatively low accuracy may require a correspondingly low amount of processing time, permitting a real-time rendering of the 3-D space with a blurring effect without introducing lag. In some configurations the blurring module 410 may be configured to determine a first level and a second level of blur intensity. In other words, in some embodiments, a relatively low level of blur may be applied to the entire rendered depiction of the object, whereas a relatively high level of blur may be applied to the edges of the rendered depiction of the object. For instance, the blurring module 410 may apply a relatively high level of a blurring effect to the edges of a rendered pair of glasses and a relatively low level of a blurring effect to the glasses

overall. Thus, the blurring module 410 may be configured to apply the first level of blur accuracy at the first level of blur intensity to the rendered depiction of the object. In some embodiments, the edge detection module 412 may be configured to detect an edge of the rendered depiction of the object. The blurring module 410 may be configured to apply the first level of blur accuracy at the second level of blur intensity to the rendered depiction of the object. In some embodiments, upon receiving a user input to adjust the render viewpoint, the blurring module 410 may be configured to apply the second level of blur accuracy to the rendered depiction of the object.

10           **[0060]** In some configurations, the systems and methods described herein may be used to facilitate rendering a virtual try-on shopping experience. For example, a user may be presented with a pair of glasses (*e.g.*, for the first time) via a rendered virtual try-on image that illustrates the pair of glasses on the user's face, thus, enabling a user to shop for glasses and to see how the user looks in the glasses (via  
15 the virtual try-on) simultaneously.

**[0061]** FIG. 6 illustrates another example arrangement of a virtual 3-D space 600. FIG. 6 depicts different stages of the rendering process of the render module 402 from application of the shadow texture map, to the application of the transparency texture and color texture maps. The virtual 3-D space 600 includes a depiction of the 3-D model of the user 502 and the shadow texture map 504 similar to the depiction in FIG. 5. Additionally, FIG. 6 depicts texture maps associated with a 3-D polygon mesh of a pair of glasses, including the application of the color and transparency texture maps of the right arm 602, the application of the color and transparency texture maps of the right lens and frame 604, the application of the color and transparency texture maps of the left lens and frame 606, and the application of the color and transparency texture maps of the left arm 608. Thus, as depicted, with the shadow texture map 504 applied to the 3-D model of the user 502, the texture mapping module 406 may be configured to apply the combination of the transparency and color texture maps 602 to the 3-D polygon model of a pair of glasses to  
25 render a virtual 3-D view of the user wearing a particular model of glasses.  
30

**[0062]** FIG. 7 is a flow diagram illustrating one embodiment of a method 700 to render a virtual 3-D space. In some configurations, the method 700 may be

implemented by the rendering module 104 illustrated in FIGS. 1, 2, or 4. In some configurations, the method 700 may be implemented by the application 202 illustrated in FIG. 2.

5 [0063] At block 702, a render viewpoint of a virtual 3-D space may be selected. The virtual 3-D space may include a 3-D model of at least a portion of a user generated from an image of the user and a 3-D polygon mesh of an object. At block 704, a first polygon of the 3-D polygon mesh of the object may be designated as a backwards-facing polygon in relation to the render viewing angle. At block 706, a second polygon of the 3-D polygon mesh of the object may be designated as a front-  
10 facing polygon in relation to the render viewing angle.

[0064] At block 708, a shadow texture map of the object may be applied to the 3-D model of the user at the render viewing angle. At block 710, a transparency texture map of the object may be applied to the backwards-facing polygon of the 3-D polygon mesh of the object at the render viewing angle. At block 712, a first color  
15 texture map of the object may be applied to the result of the application of the transparency texture map to the backwards-facing polygon.

[0065] At block 714, a transparency texture map of the object may be applied to the backwards-facing polygon of the 3-D polygon mesh of the object at the render viewing angle. At block 716, the first color texture map of the object may be  
20 applied to the result of the application of the transparency texture map to the backwards-facing polygon. At block 718, the virtual 3-D space may be rendered at the render viewing angle. At block 720, a determination may be made whether there is another viewing angle to render. If it is determined that there is another viewing angle to render, then the method 700 returns to block 702.

25 [0066] FIG. 8 is a flow diagram illustrating one embodiment of a method 800 to create a shadow texture map. In some configurations, the method 800 may be implemented by the rendering module 104 illustrated in FIGS. 1, 2, or 4. In some configurations, the method 800 may be implemented by the application 202 illustrated in FIG. 2.

30 [0067] At block 802, a shadow value of an object may be detected from a scan of the object. At block 804, a shadow texture map may be created from the detected shadow value. At block 806, a 2-D coordinate of the shadow texture map may

be mapped to a point on the 3-D model of the user. At block 808, a value of the point on the 3-D model of the user may be multiplied by the shadow value.

[0068] FIG. 9 is a flow diagram illustrating one embodiment of a method 900 to create a transparency texture map. In some configurations, the method 900 may be implemented by the rendering module 104 illustrated in FIGS. 1, 2, or 4. In some configurations, the method 900 may be implemented by the application 202 illustrated in FIG. 2.

[0069] At block 902, a transparency value of an object may be detected from a scan of the object. At block 904, a transparency texture map may be created from the detected transparency value. At block 906, a 2-D coordinate of the transparency texture map may be mapped to a point on the 3-D model of the user. At block 908, a value of the point on the 3-D model of the user may be multiplied by the transparency value.

[0070] FIG. 10 is a flow diagram illustrating one embodiment of a method 1000 to create a color texture map. In some configurations, the method 1000 may be implemented by the rendering module 104 illustrated in FIGS. 1, 2, or 4. In some configurations, the method 1000 may be implemented by the application 202 illustrated in FIG. 2.

[0071] At block 1002, a scanning angle of a scan of an object may be selected. The scanning angle may correspond to a render viewing angle of a 3-D polygon mesh of the object. At block 1004, a color value of an object may be detected from a scan of the object. At block 1006, a color texture map may be created from the detected color value. At block 1008, a 2-D coordinate of the color texture map may be mapped to a point on the 3-D model of the user. At block 1010, a value of the point on the 3-D model of the user may be multiplied by the color value. At block 1012, a determination may be made whether there is another scanning angle to process. If it is determined that there is another scanning angle to process, then the method 1000 returns to block 1002.

[0072] FIG. 11 is a flow diagram illustrating another embodiment of a method 1100 to render the virtual 3-D space. In some configurations, the method 1100 may be implemented by the rendering module 104 illustrated in FIGS. 1, 2, or



4. In some configurations, the method 1100 may be implemented by the application 202 illustrated in FIG. 2.

[0073] At block 1102, the 3-D polygon mesh of the object may be divided into multiple parts. At block 1104, an order may be determined to the multiple parts  
5 of the divided 3-D polygon mesh of the object from furthest part to closest part relative to the determined render viewing angle of the virtual 3-D space.

[0074] At block 1106, it is determined which portions of the 3-D polygon mesh of the object are visible in relation to the 3-D model of the user based on the determined render viewing angle. At block 1108, the 3-D polygon mesh of the ob-  
10 ject is rendered from the furthest part to the closest part based on the determined visible portions of the 3-D polygon mesh of the object.

[0075] FIG. 12 is a flow diagram illustrating one embodiment of a method 1200 to apply a blurring effect to a rendered depiction of the object. In some configurations, the method 1200 may be implemented by the rendering module 104 illus-  
15 trated in FIGS. 1, 2, or 4. In some configurations, the method 1200 may be implemented by the application 202 illustrated in FIG. 2.

[0076] At block 1202, a first level and a second level of blur accuracy may be determined. At block 1204, a first level and a second level of blur intensity may be determined. At block 1206, the first level of blur accuracy may be applied at the  
20 first level of blur intensity to the rendered depiction of the object.

[0077] At block 1208, an edge of the rendered depiction of the object may be detected. At block 1210, the first level of blur accuracy may be applied at the second level of blur intensity to the detected edges of the rendered depiction of the ob-  
ject. At block 1212, upon receiving a user input to adjust the render viewing angle,  
25 the second level of blur accuracy is applied to the rendered depiction of the object.

[0078] FIG. 13 depicts a block diagram of a computer system 1300 suitable for implementing the present systems and methods. Computer system 1310 includes a bus 1312 which interconnects major subsystems of computer system 1310, such as a central processor 1314, a system memory 1316 (typically RAM, but which  
30 may also include ROM, flash RAM, or the like), an input/output controller 1318, an external audio device, such as a speaker system 1320 via an audio output interface 1322, an external device, such as a display screen 1324 via display adapter 1326, an

keyboard 1332 (interfaced with a keyboard controller 1333) (or other input device), multiple USB devices 1392 (interfaced with a USB controller 1391), and a storage interface 1334. Also included are a mouse 1346 (or other point-and-click device) and a network interface 1348 (coupled directly to bus 1312).

5           **[0079]** Bus 1312 allows data communication between central processor 1314 and system memory 1316, which may include read-only memory (ROM) or flash memory (neither shown), and random access memory (RAM) (not shown), as previously noted. The RAM is generally the main memory into which the operating system and application programs are loaded. The ROM or flash memory can contain, among other code, the Basic Input-Output system (BIOS) which controls basic hardware operation such as the interaction with peripheral components or devices. For example, the rendering module 104-c to implement the present systems and methods may be stored within the system memory 1316. Applications (*e.g.*, application 202) resident with computer system 1310 are generally stored on and accessed via a non-transitory computer readable medium, such as a hard disk drive (*e.g.*, fixed disk 1344) or other storage medium. Additionally, applications can be in the form of electronic signals modulated in accordance with the application and data communication technology when accessed via interface 1348.

10           **[0080]** Storage interface 1334, as with the other storage interfaces of computer system 1310, can connect to a standard computer readable medium for storage and/or retrieval of information, such as a fixed disk drive 1344. Fixed disk drive 1344 may be a part of computer system 1310 or may be separate and accessed through other interface systems. Network interface 1348 may provide a direct connection to a remote server via a direct network link to the Internet via a POP (point of presence). Network interface 1348 may provide such connection using wireless techniques, including digital cellular telephone connection, Cellular Digital Packet Data (CDPD) connection, digital satellite data connection, or the like.

25           **[0081]** Many other devices or subsystems (not shown) may be connected in a similar manner (*e.g.*, document scanners, digital cameras, and so on). Conversely, all of the devices shown in FIG. 13 need not be present to practice the present systems and methods. The devices and subsystems can be interconnected in different ways from that shown in FIG. 13. The operation of a computer system such as that

shown in FIG. 13 is readily known in the art and is not discussed in detail in this application. Code to implement the present disclosure can be stored in a non-transitory computer-readable medium such as one or more of system memory 1316 or fixed disk 1344. The operating system provided on computer system 1310 may be iOS<sup>®</sup>, MS-DOS<sup>®</sup>, MS-WINDOWS<sup>®</sup>, OS/2<sup>®</sup>, UNIX<sup>®</sup>, Linux<sup>®</sup>, or another known operating system.

[0082] Moreover, regarding the signals described herein, those skilled in the art will recognize that a signal can be directly transmitted from a first block to a second block, or a signal can be modified (*e.g.*, amplified, attenuated, delayed, latched, buffered, inverted, filtered, or otherwise modified) between the blocks. Although the signals of the above described embodiment are characterized as transmitted from one block to the next, other embodiments of the present systems and methods may include modified signals in place of such directly transmitted signals as long as the informational and/or functional aspect of the signal is transmitted between blocks. To some extent, a signal input at a second block can be conceptualized as a second signal derived from a first signal output from a first block due to physical limitations of the circuitry involved (*e.g.*, there will inevitably be some attenuation and delay). Therefore, as used herein, a second signal derived from a first signal includes the first signal or any modifications to the first signal, whether due to circuit limitations or due to passage through other circuit elements which do not change the informational and/or final functional aspect of the first signal.

[0083] While the foregoing disclosure sets forth various embodiments using specific block diagrams, flowcharts, and examples, each block diagram component, flowchart step, operation, and/or component described and/or illustrated herein may be implemented, individually and/or collectively, using a wide range of hardware, software, or firmware (or any combination thereof) configurations. In addition, any disclosure of components contained within other components should be considered exemplary in nature since many other architectures can be implemented to achieve the same functionality.

[0084] The process parameters and sequence of steps described and/or illustrated herein are given by way of example only and can be varied as desired. For example, while the steps illustrated and/or described herein may be shown or dis-

cussed in a particular order, these steps do not necessarily need to be performed in the order illustrated or discussed. The various exemplary methods described and/or illustrated herein may also omit one or more of the steps described or illustrated herein or include additional steps in addition to those disclosed.

5           **[0085]** Furthermore, while various embodiments have been described and/or illustrated herein in the context of fully functional computing systems, one or more of these exemplary embodiments may be distributed as a program product in a variety of forms, regardless of the particular type of computer-readable media used to actually carry out the distribution. The embodiments disclosed herein may also be  
10 implemented using software modules that perform certain tasks. These software modules may include script, batch, or other executable files that may be stored on a computer-readable storage medium or in a computing system. In some embodiments, these software modules may configure a computing system to perform one or more of the exemplary embodiments disclosed herein.

15           **[0086]** The foregoing description, for purpose of explanation, has been described with reference to specific embodiments. However, the illustrative discussions above are not intended to be exhaustive or to limit the invention to the precise forms disclosed. Many modifications and variations are possible in view of the above teachings. The embodiments were chosen and described in order to best explain  
20 the principles of the present systems and methods and their practical applications, to thereby enable others skilled in the art to best utilize the present systems and methods and various embodiments with various modifications as may be suited to the particular use contemplated.

**[0087]** Unless otherwise noted, the terms “a” or “an,” as used in the specification and claims, are to be construed as meaning “at least one of.” In addition, for ease of  
25 use, the words “including” and “having,” as used in the specification and claims, are interchangeable with and have the same meaning as the word “comprising.” In addition, the term “based on” as used in the specification and the claims is to be construed as meaning “based at least upon.”

30

What is claimed is:

1. A computer-implemented method for rendering virtual try-on products, the method comprising:
  - 5 selecting a first render viewpoint of a virtual 3-D space, wherein the virtual 3-D space comprises a 3-D model of at least a portion of a user generated from an image of the user and a 3-D polygon mesh of an object;  
designating a first polygon of the 3-D polygon mesh of the object as a backwards-facing polygon in relation to the first render viewpoint;
  - 10 designating a second polygon of the 3-D polygon mesh of the object as a front-facing polygon in relation to the first render viewpoint;  
applying a shadow texture map of the object to the 3-D model of the user;  
applying a transparency texture map of the object to the backwards-facing polygon of the 3-D polygon mesh of the object;
  - 15 applying a first color texture map of the object to the result of the application of the transparency texture map to the backwards-facing polygon; and  
rendering the virtual 3-D space at the first render viewpoint.
2. The method of claim 1, further comprising:
  - 20 applying the transparency texture map of the object to the front-facing polygon of the 3-D polygon mesh of the object; and  
applying the first color texture map of the object to the result of the application of the transparency texture map to the front-facing polygon.
- 25 3. The method of claim 1, further comprising:
  - placing at least a portion of the 3-D polygon mesh of the object within a pre-determined distance of at least one point on the 3-D model of the user, wherein the application of the shadow texture map is based on the position of the 3-D polygon mesh of the object in relation to the 3-D model
  - 30 of the user.

4. The method of claim 1, further comprising:  
detecting a shadow value of the object from a scan of the object; and  
creating the shadow texture map from the detected shadow value.
- 5 5. The method of claim 4, further comprising:  
mapping a 2-D coordinate of the shadow texture map to a point on the 3-D  
model of the user; and  
multiplying a value of the point on the 3-D model of the user by the shadow  
value.
- 10 6. The method of claim 1, further comprising:  
detecting a transparency value of the object from a scan of the object; and  
creating the transparency texture map from the detected transparency value.
- 15 7. The method of claim 6, further comprising:  
mapping a 2-D coordinate of the transparency texture map to a point on the 3-  
D model of the user and the 3-D polygon mesh of the object; and  
multiplying a value of the point on the 3-D model of the user by the transpar-  
ency value.
- 20 8. The method of claim 7, further comprising:  
selecting a first scanning angle of a scan of an object, wherein the first scan-  
ning angle corresponds to the first render viewpoint;  
detecting a first color value of the object at the first scanning angle;  
25 creating the first color texture map from the detected first color value.
9. The method of claim 8, further comprising:  
mapping a 2-D coordinate of the first color texture map to the point on the 3-  
D model of the user and the 3-D polygon mesh of the object; and  
30 multiplying the resultant value of the point on the 3-D model of the user and  
the 3-D polygon mesh of the object by the first color value.

10. The method of claim 1, further comprising:  
selecting a second render viewpoint of the virtual 3-D space.
11. The method of claim 10, further comprising:  
5 selecting a second scanning angle of a scan of an object, wherein the second scanning angle corresponds to the second render viewpoint;  
detecting a second color value of the object at the second scanning angle; and  
creating a second color texture map from the detected second color value.
- 10 12. The method of claim 10, further comprising:  
applying the shadow texture map of the object to the 3-D model of the user at  
the second render viewpoint;  
applying the transparency texture map of the object to the backwards-facing  
15 polygon of the 3-D polygon mesh of the object at the second render  
viewpoint; and  
applying the second color texture map of the object to the result of the appli-  
cation of the transparency texture map to the backwards-facing poly-  
gon at the second render viewpoint.
- 20 13. The method of claim 10, further comprising:  
applying the transparency texture map of the object to the front-facing poly-  
gon of the 3-D polygon mesh of the object at the second render view-  
point; and  
applying the second color texture map of the object to the result of the appli-  
25 cation of the transparency texture map to the front-facing polygon at  
the second render viewpoint;  
rendering the virtual 3-D space at the second render viewpoint.

14. The method of claim 1, further comprising:  
dividing the 3-D polygon mesh of the object into two or more portions;  
determining an order to the portions of the divided 3-D polygon mesh of the  
object from furthest portion to closest portion relative to the deter-  
mined render viewpoint of the virtual 3-D space;  
5 rendering the 3-D polygon mesh of the object from the furthest portion to the  
closest portion.
15. The method of claim 1, further comprising:  
10 determining whether a portion of the 3-D polygon mesh of the object is visi-  
ble in relation to the 3-D model of the user based on the determined  
render viewpoint, wherein rendering the scene comprises rendering the  
scene based on a visible portion of the 3-D polygon mesh of the object.
- 15 16. The method of claim 1, further comprising:  
determining a first level and a second level of blur accuracy;  
determining a first level and a second level of blur intensity; and  
applying the first level of blur accuracy at the first level of blur intensity to  
the rendered depiction of the object.  
20
17. The method of claim 16, further comprising:  
detecting an edge of the rendered depiction of the object; and  
applying the first level of blur accuracy at the second level of blur intensity to  
the rendered depiction of the object.  
25
18. The method of claim 16, further comprising:  
upon receiving a user input to adjust the render viewpoint, applying the se-  
cond level of blur accuracy to the rendered depiction of the object.



19. A computing device configured to render virtual try-on products, comprising:  
a processor;  
memory in electronic communication with the processor;  
instructions stored in the memory, the instructions being executable by  
5 the processor to:  
select a first render viewpoint of a virtual 3-D space, wherein  
the virtual 3-D space comprises a 3-D model of at least a  
portion of a user generated from an image of the user and  
a 3-D polygon mesh of an object;  
10 designate a first polygon of the 3-D polygon mesh of the object  
as a backwards-facing polygon in relation to the first render  
viewpoint;  
designate a second polygon of the 3-D polygon mesh of the ob-  
ject as a front-facing polygon in relation to the first render  
15 viewpoint;  
apply a shadow texture map of the object to the 3-D model of  
the user;  
apply a transparency texture map of the object to the backwards-  
facing polygon of the 3-D polygon mesh of the object;  
20 apply a first color texture map of the object to the result of the  
application of the transparency texture map to the back-  
wards-facing polygon; and  
render the virtual 3-D space at the first render viewpoint.
- 25 20. The computing device of claim 19, wherein the instructions are executable by  
the processor to:  
apply the transparency texture map of the object to the front-facing  
polygon of the 3-D polygon mesh of the object; and  
30 apply the first color texture map of the object to the result of the appli-  
cation of the transparency texture map to the front-facing poly-  
gon.

21. The computing device of claim 19, wherein the instructions are executable by the processor to:

detect a shadow value of the object from a scan of the object; and  
create the shadow texture map from the detected shadow value.

5

22. The computing device of claim 21, wherein the instructions are executable by the processor to:

map a 2-D coordinate of the shadow texture map to a point on the 3-D  
model of the user; and

10

multiply a value of the point on the 3-D model of the user by the shadow value.

23. The computing device of claim 19, wherein, upon determining the first application is a trusted application, the instructions are executable by the processor to:

15

detect a transparency value of the object from a scan of the object; and  
create the transparency texture map from the detected transparency  
value.

24. The computing device of claim 23, wherein the instructions are executable by the processor to:

20

map a 2-D coordinate of the transparency texture map to a point on the  
3-D model of the user and the 3-D polygon mesh of the object;  
and

25

multiply a value of the point on the 3-D model of the user by the transparency value.

25. The computing device of claim 24, wherein the instructions are executable by the processor to:

30

select a first scanning angle of a scan of an object where the scanning  
angle corresponds to the first render viewpoint;  
detect a first color value of the object at the first scanning angle;  
create the first color texture map from the detected first color value.

26. The computing device of claim 25, wherein the instructions are executable by the processor to:

5 map a 2-D coordinate of the first color texture map to the point on the 3-D model of the user and the 3-D polygon mesh of the object;  
and

multiply the resultant value of the point on the 3-D model of the user and the 3-D polygon mesh of the object by the first color value.

10 27. The computing device of claim 19, wherein the instructions are executable by the processor to:

select a second render viewpoint of the virtual 3-D space.

15 28. The computing device of claim 27, wherein the instructions are executable by the processor to:

select a second scanning angle of a scan of an object, wherein the second scanning angle corresponds to the second render viewpoint;

20 detect a second color value of the object at the second scanning angle;  
and

create a second color texture map from the detected second color value.

29. The computing device of claim 27, wherein the instructions are executable by the processor to:

25 apply the shadow texture map of the object to the 3-D model of the user at the second render viewpoint;

apply the transparency texture map of the object to the backwards-facing polygon of the 3-D polygon mesh of the object at the second render viewpoint; and

30 apply the second color texture map of the object to the result of the application of the transparency texture map to the backwards-facing polygon at the second render viewpoint.

30. The computing device of claim 27, wherein the instructions are executable by the processor to:

5           apply the transparency texture map of the object to the front-facing polygon of the 3-D polygon mesh of the object at the second render viewpoint;

          apply the second color texture map of the object to the result of the application of the transparency texture map to the front-facing polygon at the second render viewpoint; and

10           render the virtual 3-D space at the second render viewpoint.

31. The computing device of claim 19, wherein the instructions are executable by the processor to:

          divide the 3-D polygon mesh of the object into two or more portions;

15           determine an order to the portions of the divided 3-D polygon mesh of the object from furthest portion to closest portion relative to the determined render viewpoint of the virtual 3-D space;

          render the 3-D polygon mesh of the object from the furthest portion to the closest portion.

20

32. The computing device of claim 19, wherein the instructions are executable by the processor to:

          determine whether a portion of the 3-D polygon mesh of the object is visible in relation to the 3-D model of the user based on the determined render viewpoint, wherein the instruction to render the scene comprises an instruction to render the scene based on a visible portion of the 3-D polygon mesh of the object.

25

33. The computing device of claim 19, wherein the instructions are executable by the processor to:

determine a first level and a second level of blur accuracy;

determine a first level and a second level of blur intensity; and

5 apply the first level of blur accuracy at the first level of blur intensity to the rendered depiction of the object.

34. The computing device of claim 33, wherein the instructions are executable by the processor to:

10 detect an edge of the rendered depiction of the object; and

apply the first level of blur accuracy at the second level of blur intensity to the rendered depiction of the object.

35. The computing device of claim 33, wherein the instructions are executable by the processor to:

15 upon receiving a user input to adjust the render viewpoint, apply the second level of blur accuracy to the rendered depiction of the object.

36. A computer-program product for rendering virtual try-on products, the computer-program product comprising a non-transitory computer-readable medium storing instructions thereon, the instructions being executable by a processor to:

5           select a first render viewpoint of a virtual 3-D space, wherein the virtual 3-D space comprises a 3-D model of at least a portion of a user generated from an image of the user and a 3-D polygon mesh of an object;

10           designate a first polygon of the 3-D polygon mesh of the object as a backwards-facing polygon in relation to the first render viewpoint;

          designate a second polygon of the 3-D polygon mesh of the object as a front-facing polygon in relation to the first render viewpoint;

          apply a shadow texture map of the object to the 3-D model of the user;

15           apply a transparency texture map of the object to the backwards-facing polygon of the 3-D polygon mesh of the object;

          apply a first color texture map of the object to the result of the application of the transparency texture map to the backwards-facing polygon;

20           apply the transparency texture map of the object to the front-facing polygon of the 3-D polygon mesh of the object; and

          apply the first color texture map of the object to the result of the application of the transparency texture map to the front-facing polygon

          render the virtual 3-D space at the first render viewpoint.

25

37. The computer-program product of claim 36, wherein the instructions are executable by the processor to:

select a second render viewpoint of the virtual 3-D space;  
select a first scanning angle of a scan of an object where the scanning  
5 angle corresponds to the first render viewpoint;  
detect a second color value of the object from a scan of the object;  
create a second color texture map from the detected second color value,  
wherein the second color texture map corresponds to the second  
render viewpoint;  
10 apply the shadow texture map of the object to the 3-D model of the user at the second render viewpoint;  
apply the transparency texture map of the object to the backwards-facing polygon of the 3-D polygon mesh of the object at the second render viewpoint;  
15 apply the second color texture map of the object to the result of the application of the transparency texture map to the backwards-facing polygon at the second render viewpoint;  
apply the transparency texture map of the object to the front-facing polygon of the 3-D polygon mesh of the object at the second  
20 render viewpoint; and  
apply the second color texture map of the object to the result of the application of the transparency texture map to the front-facing polygon at the second render viewpoint; and  
render the virtual 3-D space at the second render viewpoint.

38. The computer-program product of claim 36, wherein the instructions are executable by the processor to:

determine a first level and a second level of blur accuracy;  
determine a first level and a second level of blur intensity; and  
30 apply the first level of blur accuracy at the first level of blur intensity to the rendered depiction of the object.

39. The computer-program product of claim 38, wherein the instructions are executable by the processor to:

detect an edge of the rendered depiction of the object; and

apply the first level of blur accuracy at the second level of blur intensity

5

to the rendered depiction of the object.

40. The computer-program product of claim 38, wherein the instructions are executable by the processor to:

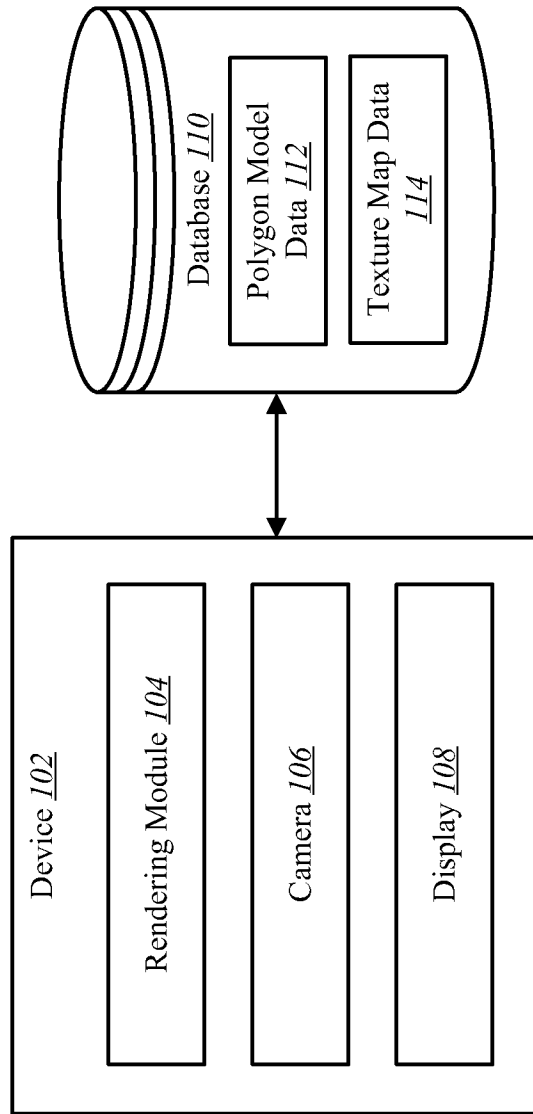
upon receiving a user input to adjust the render viewpoint, apply the

10

second level of blur accuracy to the rendered depiction of the object.

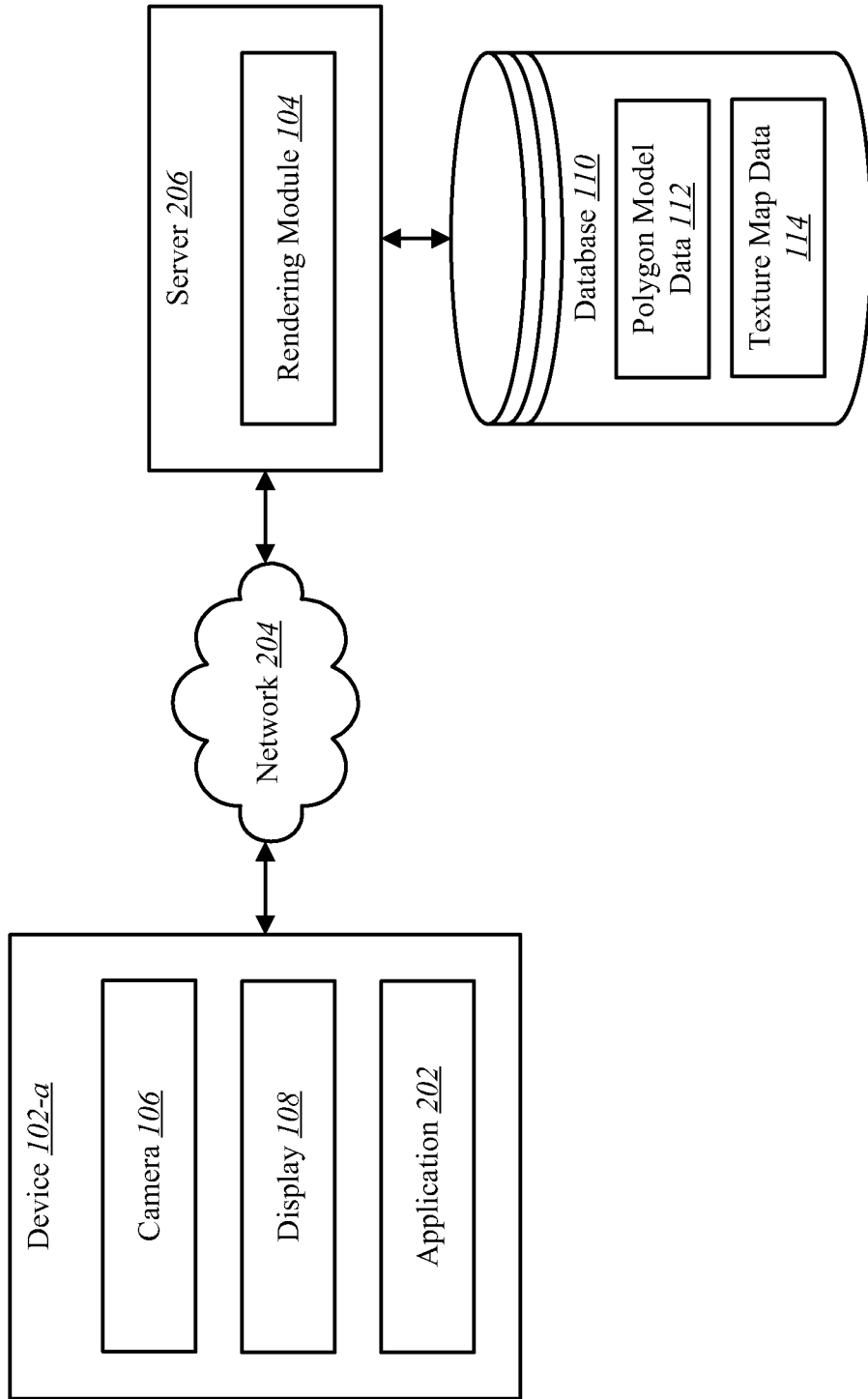


100 ↗

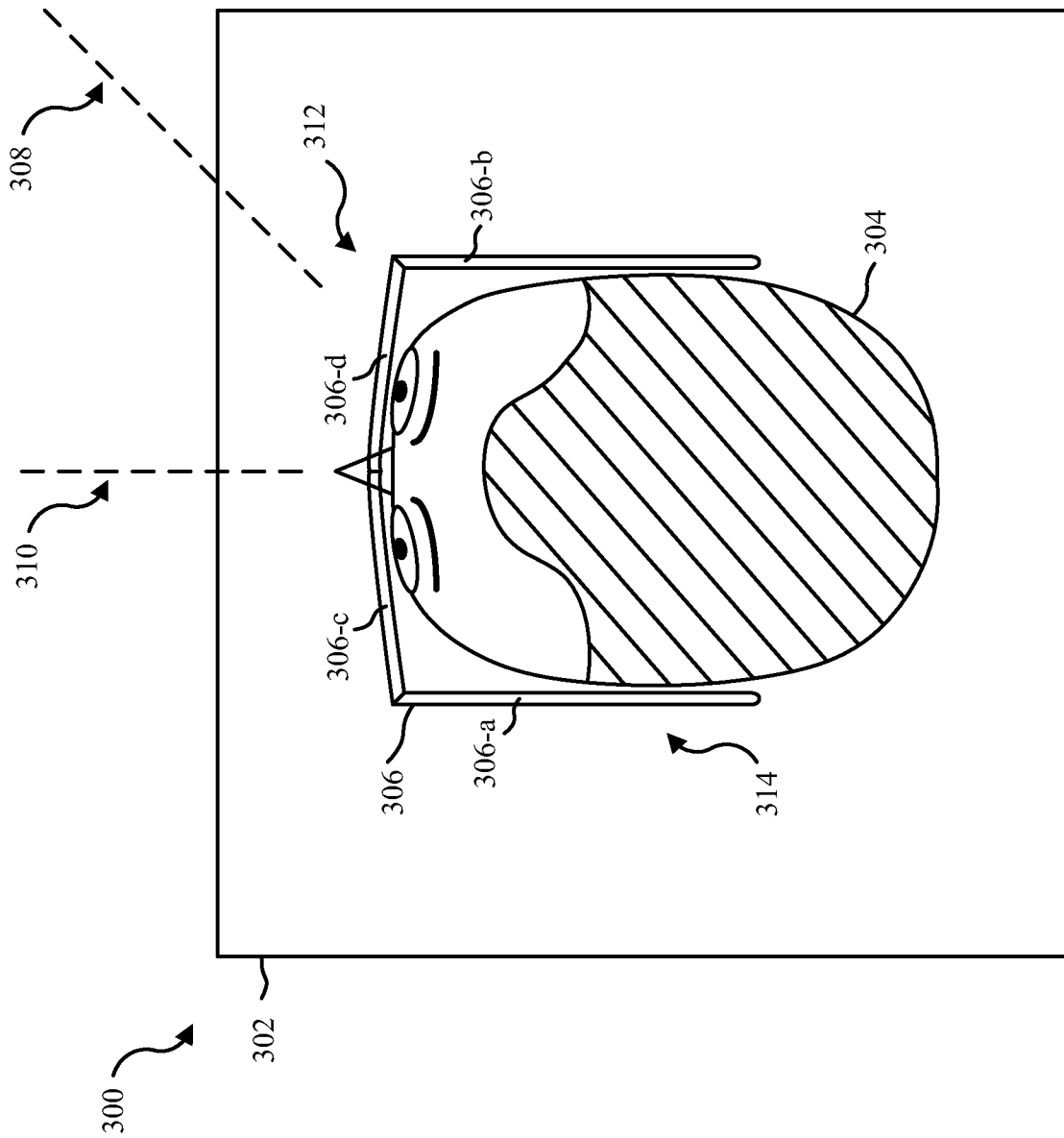


**FIG. 1**

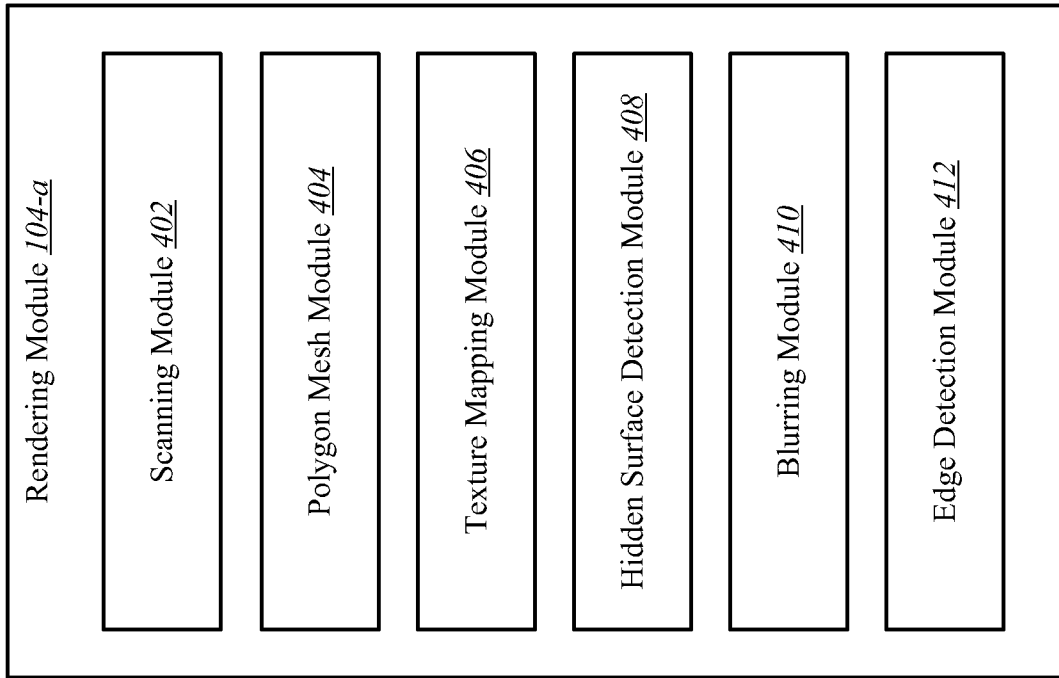
200 ↗



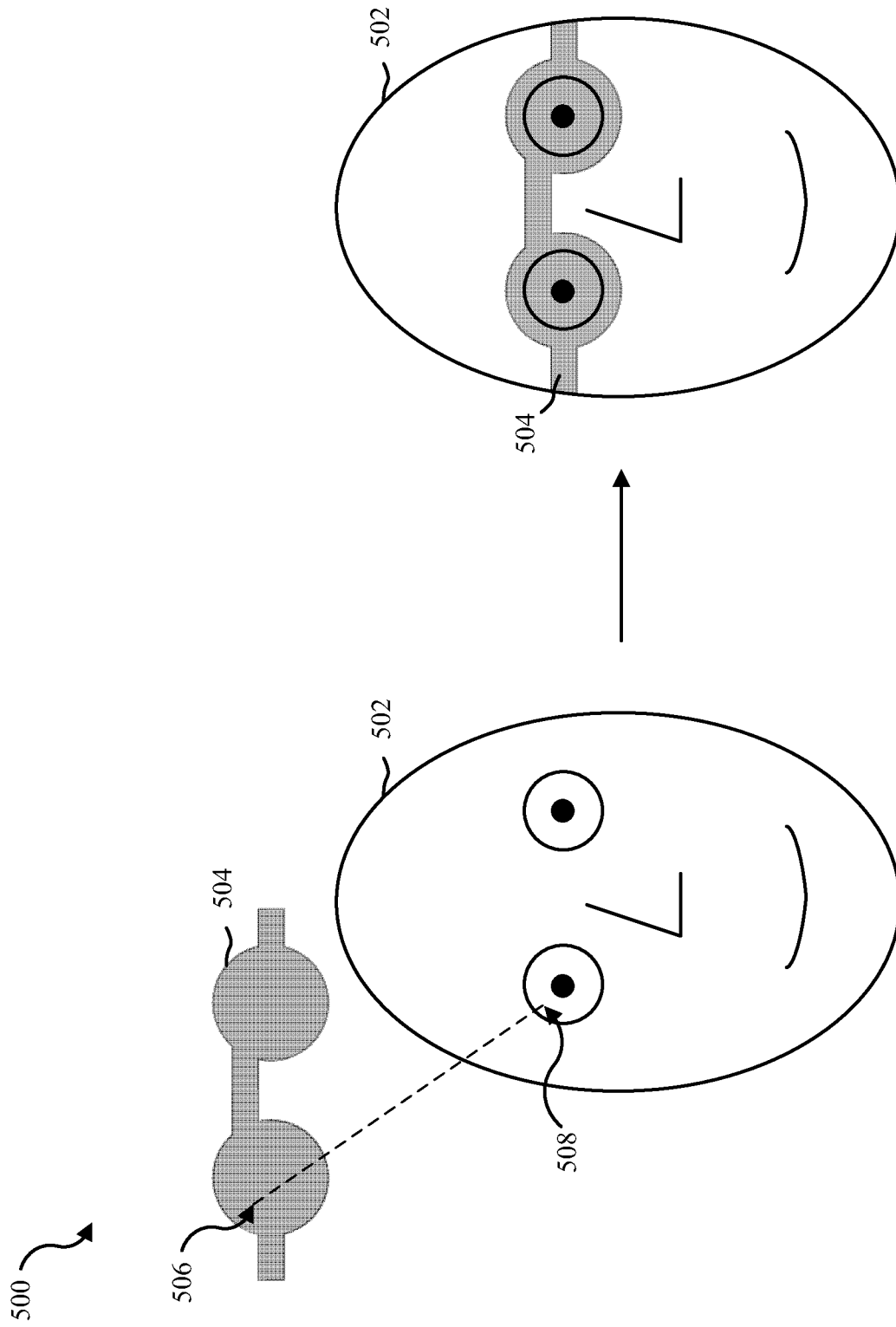
**FIG. 2**



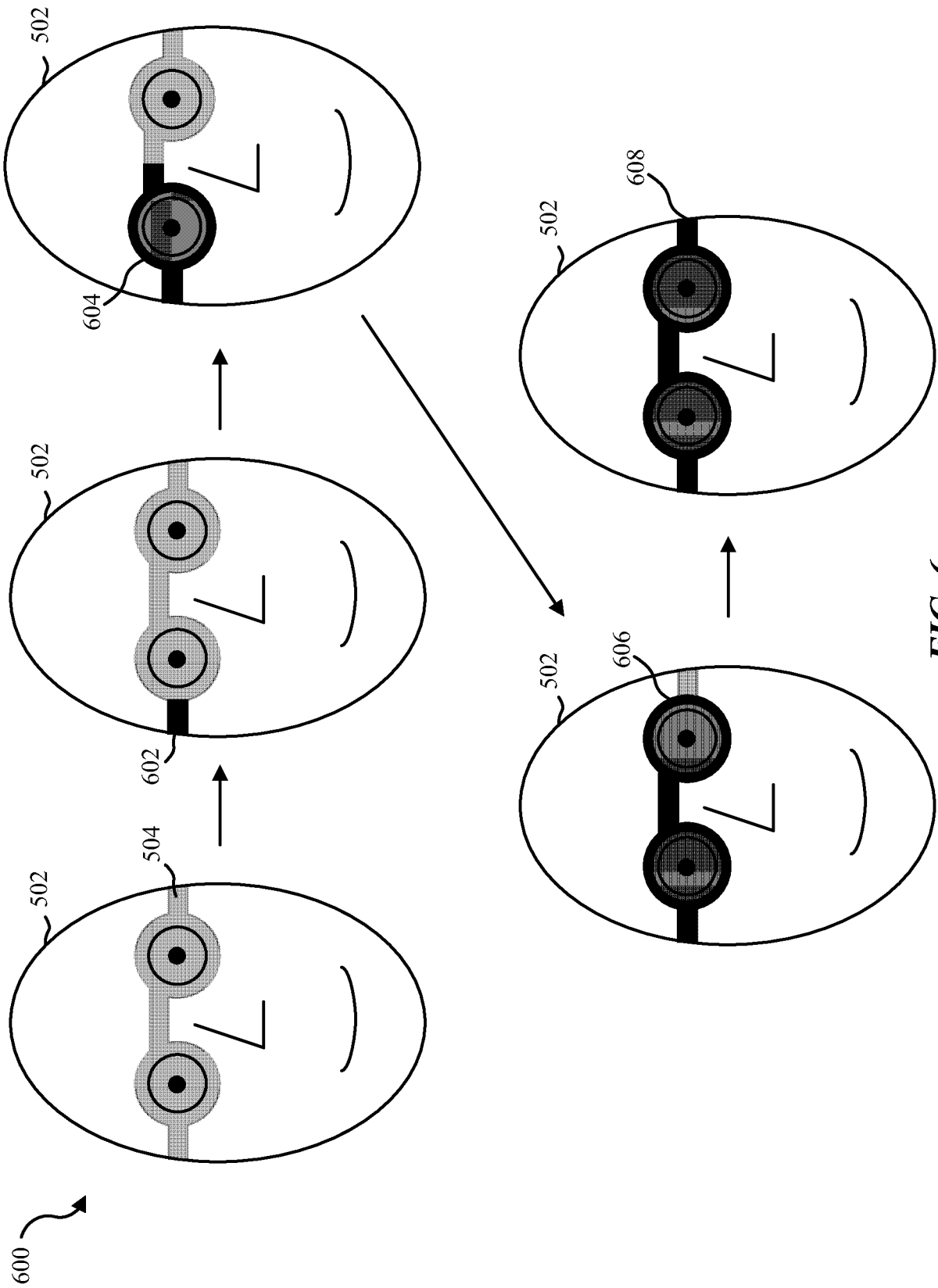
**FIG. 3**



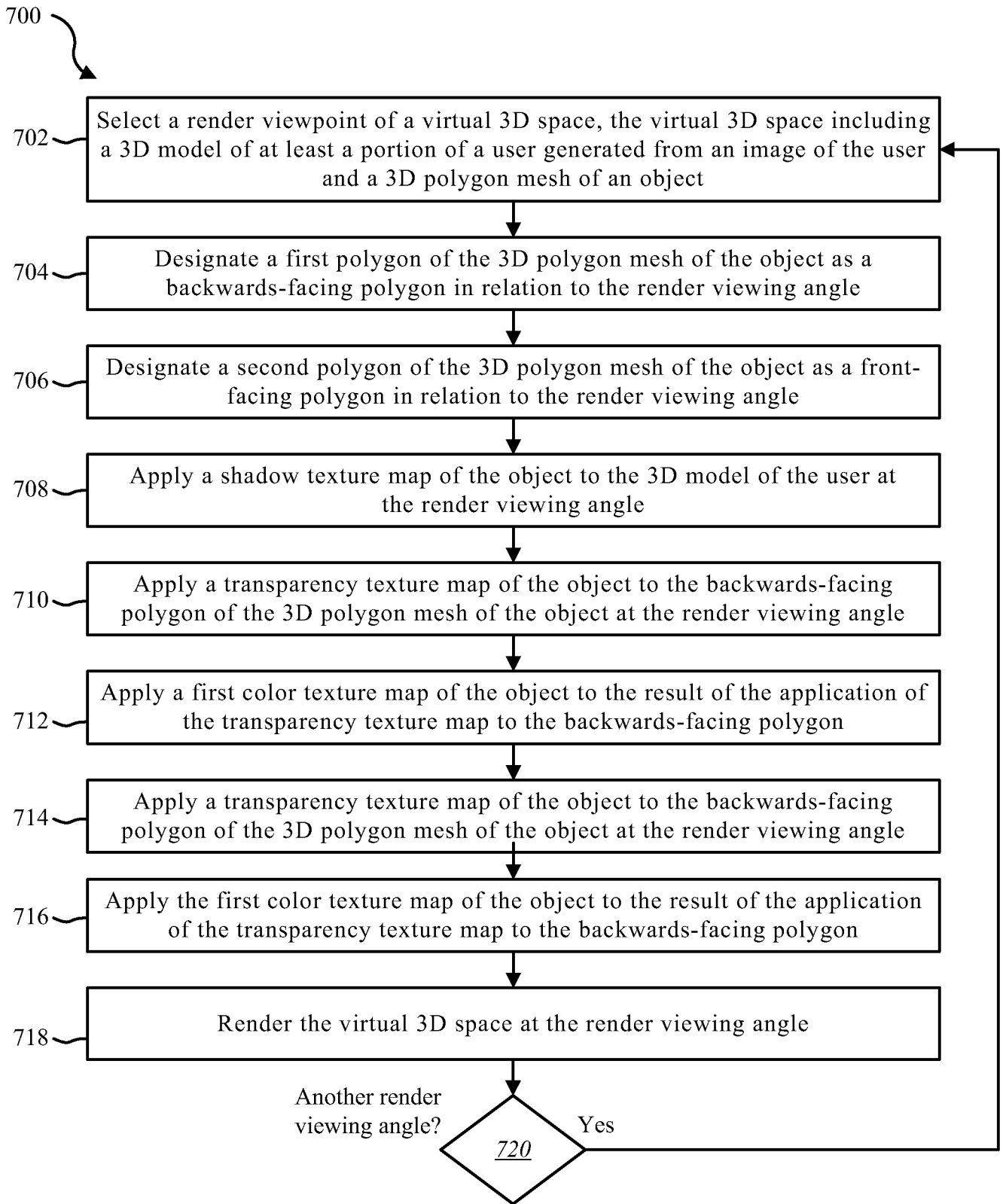
**FIG. 4**



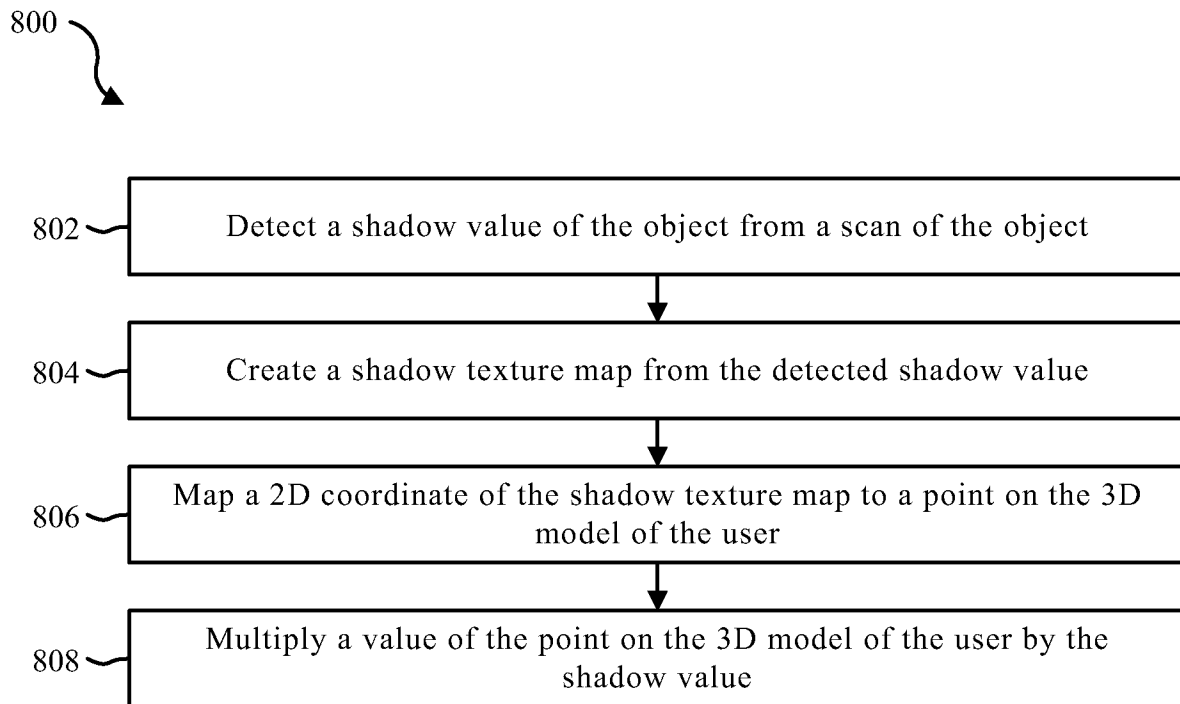
**FIG. 5**



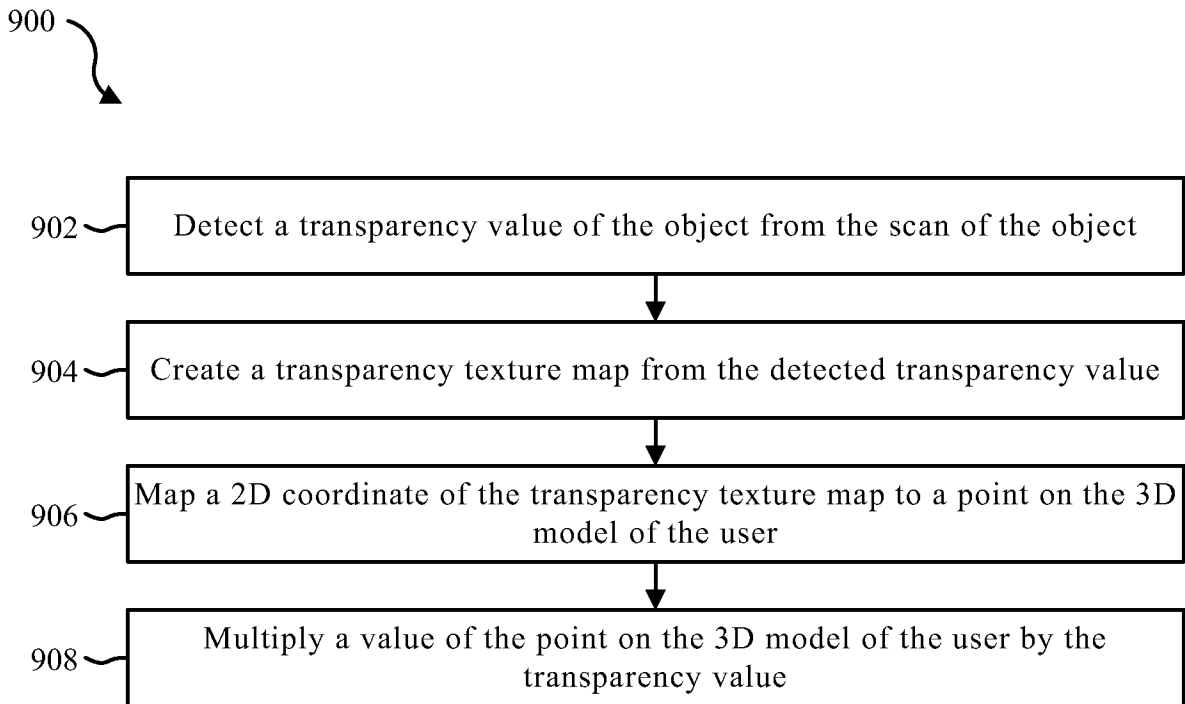
**FIG. 6**

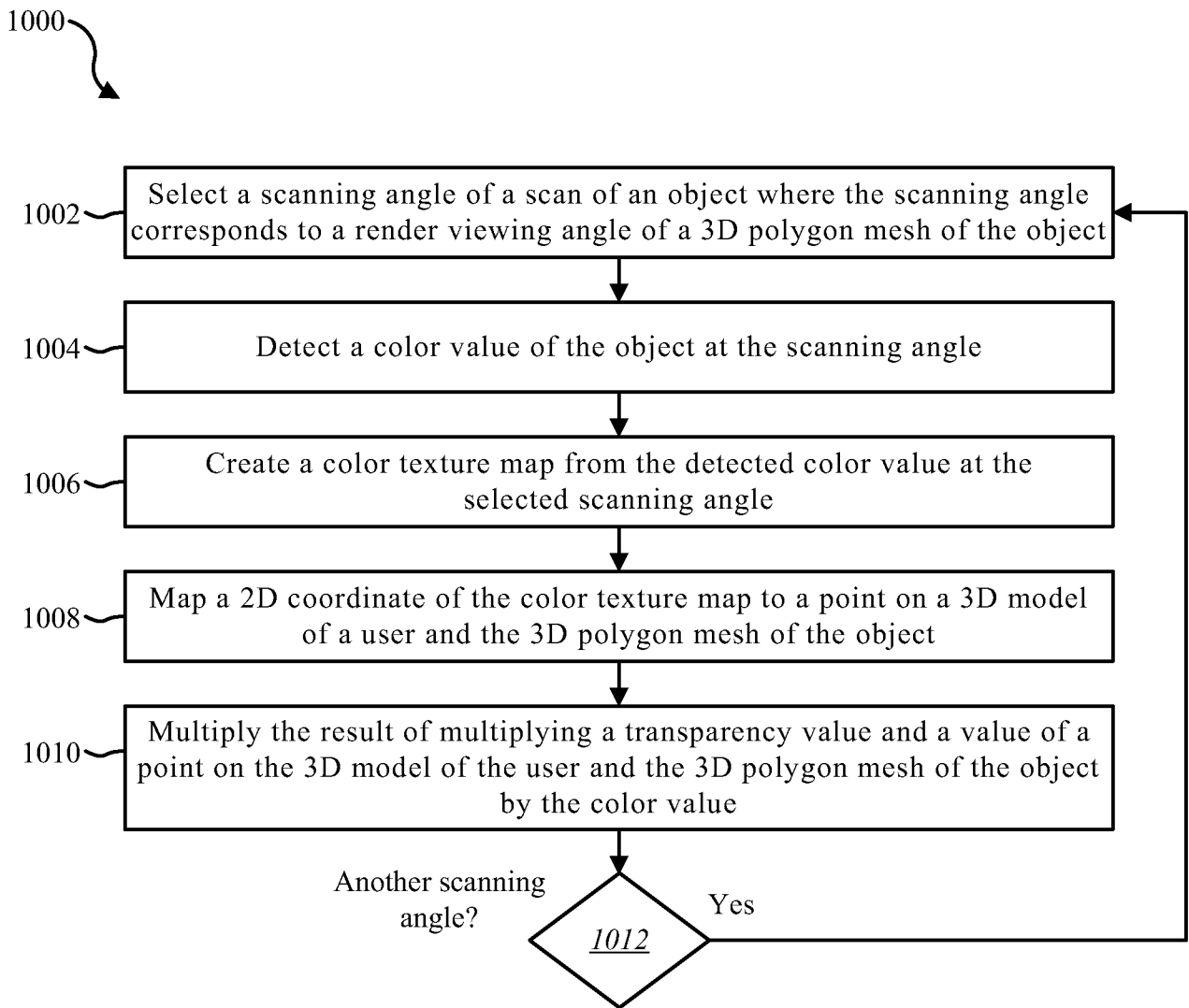


**FIG. 7**

**FIG. 8**

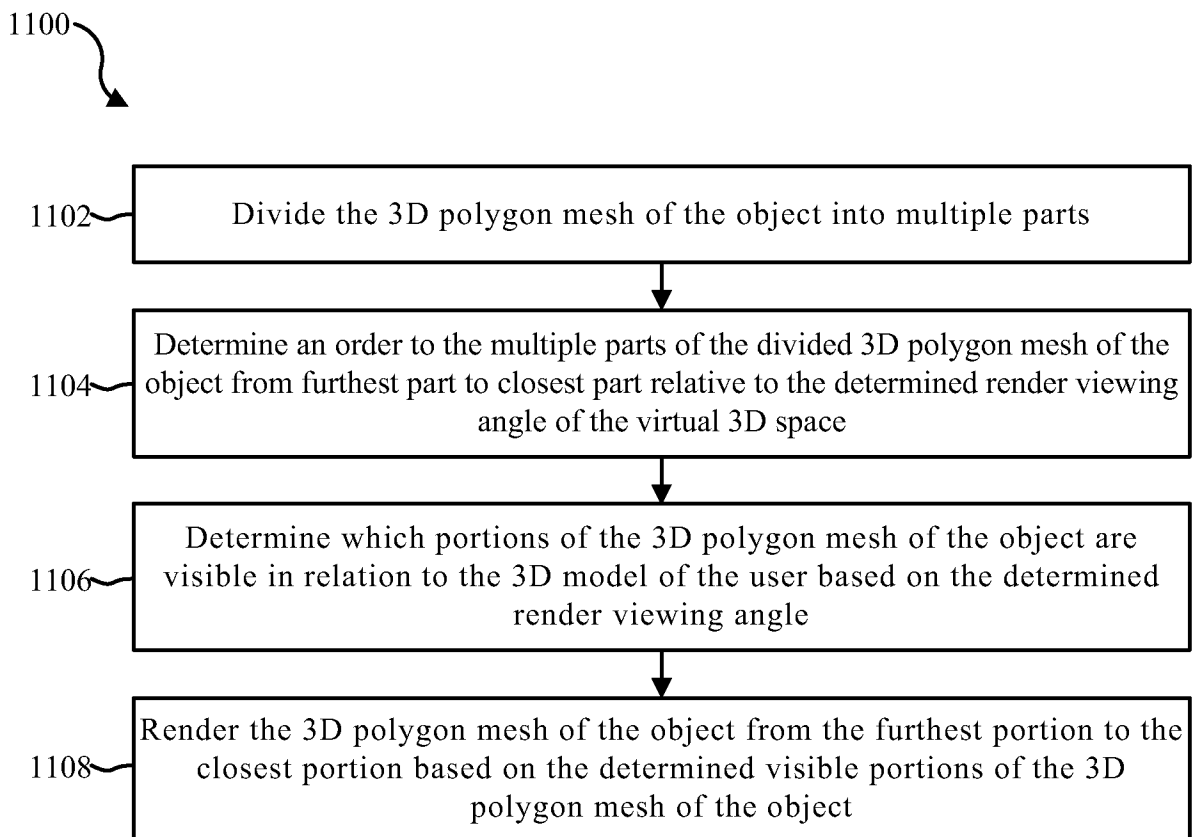


**FIG. 9**

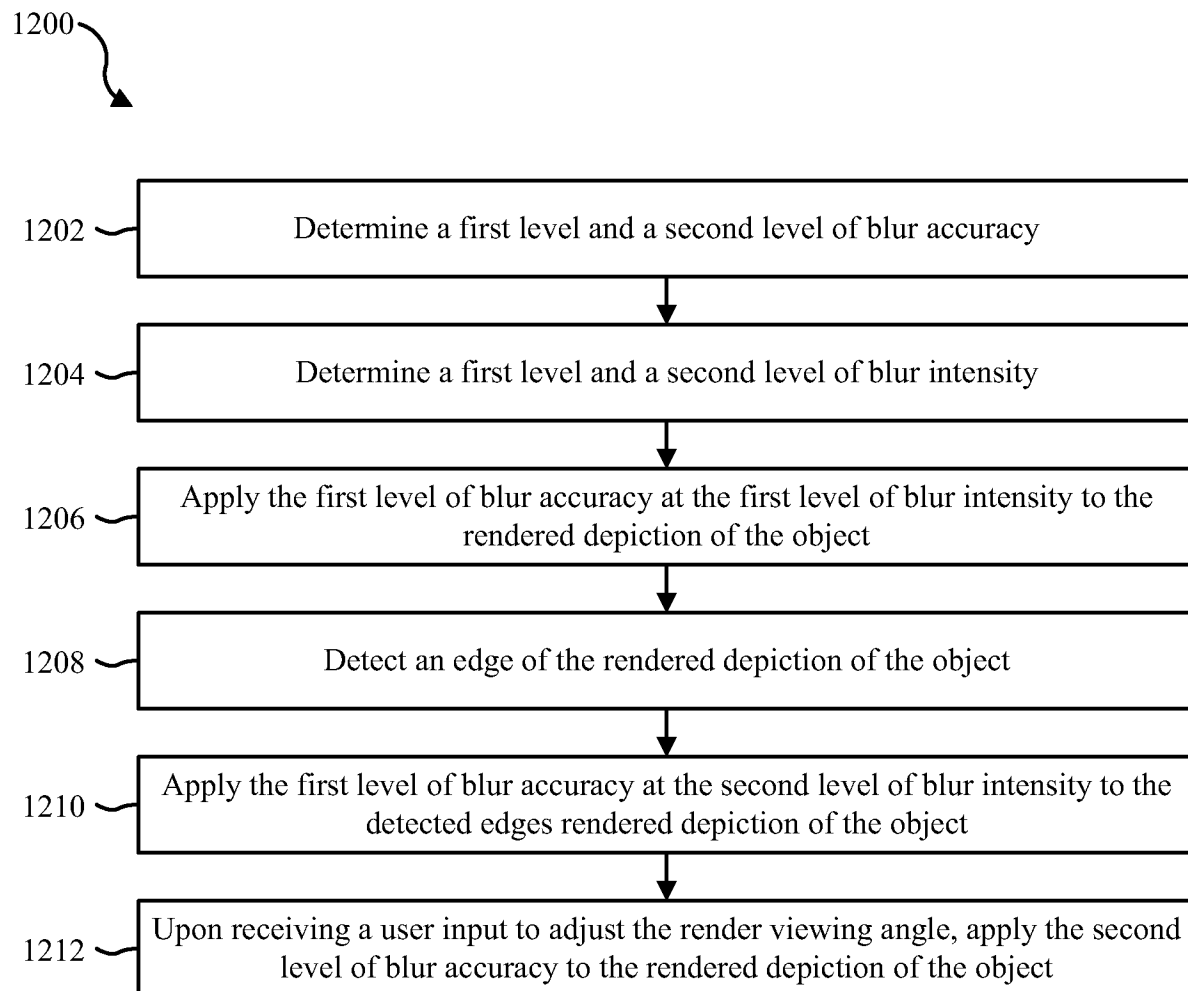


**FIG. 10**

11/13

**FIG. 11**

12/13

**FIG. 12**

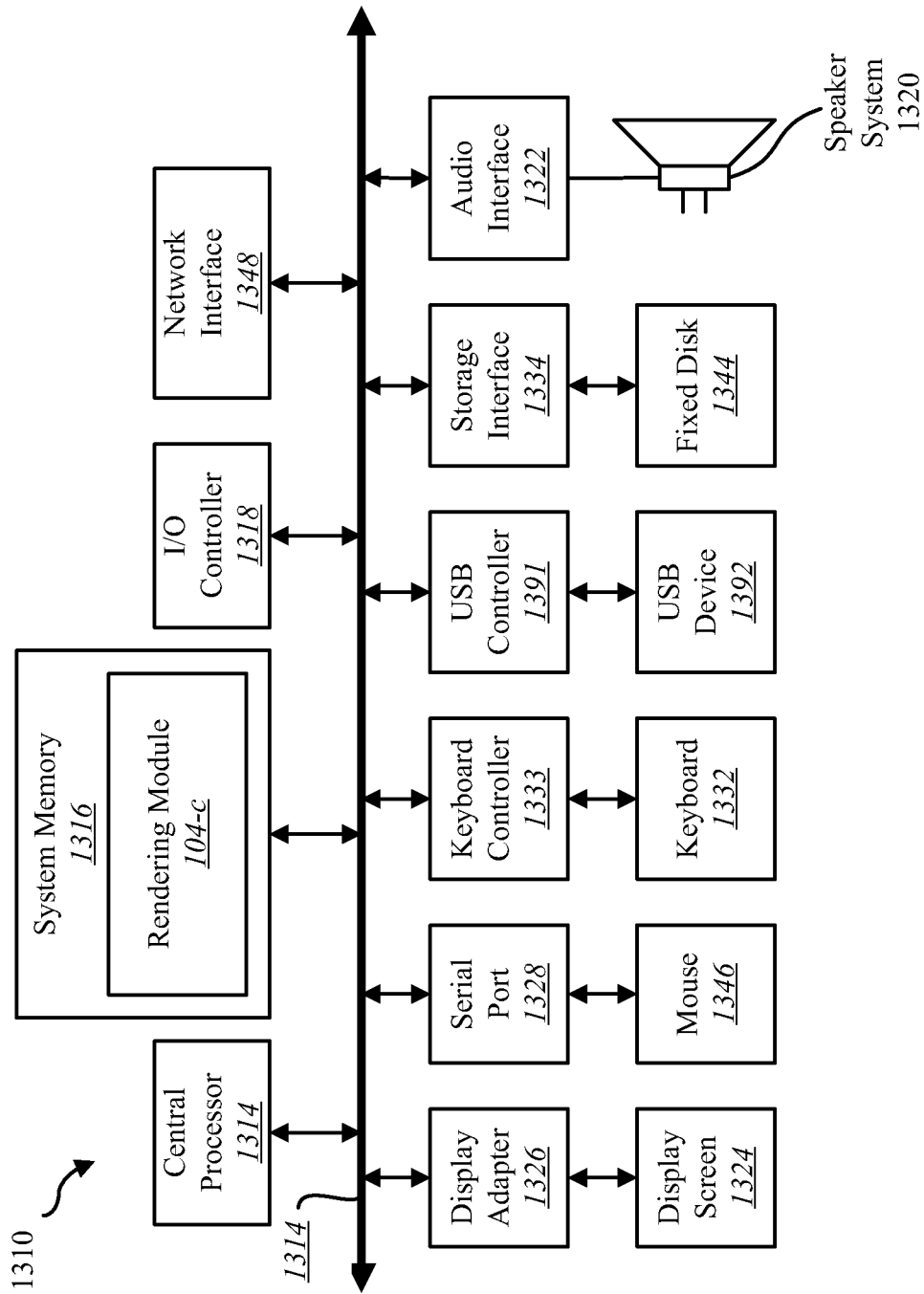


FIG. 13

## INTERNATIONAL SEARCH REPORT

International application No.  
**PCT/US2013/042517****A. CLASSIFICATION OF SUBJECT MATTER****G06T 19/00(2011.01)i, G06T 17/00(2006.01)j**

According to International Patent Classification (IPC) or to both national classification and IPC

**B. FIELDS SEARCHED**Minimum documentation searched (classification system followed by classification symbols)  
G06T 19/00; G09G 5/02; G06T 15/60; G06T 17/40; G06T 15/00; G09G 5/00; G06T 17/00Documentation searched other than minimum documentation to the extent that such documents are included in the fields searched  
Korean utility models and applications for utility models  
Japanese utility models and applications for utility modelsElectronic data base consulted during the international search (name of data base and, where practicable, search terms used)  
eKOMPASS(KIPO internal) & Keywords:virtual try-on, three dimension, rendering, polygon, texture map, shadow, transparency, color**C. DOCUMENTS CONSIDERED TO BE RELEVANT**

Category*	Citation of document, with indication, where appropriate, of the relevant passages	Relevant to claim No.
A	US 2005-0128211 A1 (TORSTEN BERGER et al.) 16 June 2005 See paragraphs [0102], [0107], [0114]-[0115], [0123]-[0124], [0127], claim 1 and figure 2.	1-40
A	US 6903746 B2 (TAKASHI FUKUSHIMA et al.) 07 June 2005 See column 4, line 45 - column 5, line 10, claim 1 and figure 3.	1-40
A	US 2004-0257364 A1 (GREGORY A. BASLER) 23 December 2004 See paragraphs [0020]-[0022], claim 1 and figure 1.	1-40
A	US 6677946 B1 (AKIO OHBA) 13 January 2004 See column 13, line 25 - column 14, line 53, claim 1 and figure 21.	1-40
A	WO 2010-042990 A1 (SEEING MACHINES LIMITED. et al.) 22 April 2010 See abstract, claim 1 and figure 3.	1-40

 Further documents are listed in the continuation of Box C. See patent family annex.

\* Special categories of cited documents:

"A" document defining the general state of the art which is not considered to be of particular relevance

"E" earlier application or patent but published on or after the international filing date

"L" document which may throw doubts on priority claim(s) or which is cited to establish the publication date of citation or other special reason (as specified)

"O" document referring to an oral disclosure, use, exhibition or other means

"P" document published prior to the international filing date but later than the priority date claimed

"T" later document published after the international filing date or priority date and not in conflict with the application but cited to understand the principle or theory underlying the invention

"X" document of particular relevance; the claimed invention cannot be considered novel or cannot be considered to involve an inventive step when the document is taken alone

"Y" document of particular relevance; the claimed invention cannot be considered to involve an inventive step when the document is combined with one or more other such documents, such combination being obvious to a person skilled in the art

"&amp;" document member of the same patent family

Date of the actual completion of the international search

28 August 2013 (28.08.2013)

Date of mailing of the international search report

**29 August 2013 (29.08.2013)**

Name and mailing address of the ISA/KR

Korean Intellectual Property Office  
189 Cheongsu-ro, Seo-gu, Daejeon Metropolitan City,  
302-701, Republic of Korea

Facsimile No. +82-42-472-7140

Authorized officer

HWANG Yun Koo

Telephone No. +82-42-481-5715



**INTERNATIONAL SEARCH REPORT**

Information on patent family members

International application No.

**PCT/US2013/042517**

Patent document cited in search report	Publication date	Patent family member(s)	Publication date
US 2005-0128211 A1	16/06/2005	US 2011-0169829 A1 US 2013-0009948 A1 US 7889209 B2 US 8174535 B2 US 8456484 B2	14/07/2011 10/01/2013 15/02/2011 08/05/2012 04/06/2013
US 6903746 B2	07/06/2005	EP 1324273 A2 EP 1324273 A3 JP 2003-051025 A JP 3527489 B2 US 2003-0025710 A1	02/07/2003 13/10/2004 21/02/2003 17/05/2004 06/02/2003
US 2004-0257364 A1	23/12/2004	None	
US 6677946 B1	13/01/2004	AU 2000-26937 A1 AU 2693700 A BR 0008818 A CA 2367152 A1 CN 1249632 C0 CN 1343343 A0 EP 1159713 A1 JP 2000-259853 A JP 3599268 B2 KR 10-2001-0113730 A RU 2001124830 A TW 459208 B WO 00-54224 A1	28/09/2000 28/09/2000 15/01/2002 14/09/2000 05/04/2006 03/04/2002 05/12/2001 22/09/2000 08/12/2004 28/12/2001 20/07/2003 11/10/2001 14/09/2000
WO 2010-042990 A1	22/04/2010	None	