



US 20040183076A1

(19) **United States**

(12) **Patent Application Publication**

**Yamazaki et al.**

(10) **Pub. No.: US 2004/0183076 A1**

(43) **Pub. Date: Sep. 23, 2004**

(54) **SEMICONDUCTOR DEVICE, METHOD OF FABRICATING SAME, AND, ELECTROOPTICAL DEVICE**

08/962,840, filed on Nov. 3, 1997, now Pat. No. 6,429,053, which is a continuation of application No. 08/575,355, filed on Dec. 20, 1995, now abandoned.

(75) Inventors: **Shunpei Yamazaki**, Setagaya (JP); **Yasuyuki Arai**, Atsugi-shi (JP); **Satoshi Teramoto**, Ayase (JP)

(30) **Foreign Application Priority Data**

Dec. 27, 1994 (JP) ..... 06-339162

Correspondence Address:

**ERIC ROBINSON**

**PMB 955**

**21010 SOUTHBANK ST.**

**POTOMAC FALLS, VA 20165 (US)**

**Publication Classification**

(51) **Int. Cl.<sup>7</sup>** ..... **H01L 31/036; H01L 21/00**

(52) **U.S. Cl.** ..... **257/72; 438/151**

(73) Assignee: **Semiconductor Energy Laboratory Co., Ltd.**, Atsugi-shi (JP)

(57) **ABSTRACT**

(21) Appl. No.: **10/815,653**

(22) Filed: **Apr. 2, 2004**

**Related U.S. Application Data**

(60) Division of application No. 09/118,010, filed on Jul. 17, 1998, which is a division of application No.

A pair of substrates forming the active matrix liquid crystal display are fabricated from resinous substrates having transparency and flexibility. A thin-film transistor has a semiconductor film formed on a resinous layer formed on one resinous substrate. The resinous layer is formed to prevent generation of oligomers on the surface of the resinous substrate during formation of the film and to planarize the surface of the resinous substrate.

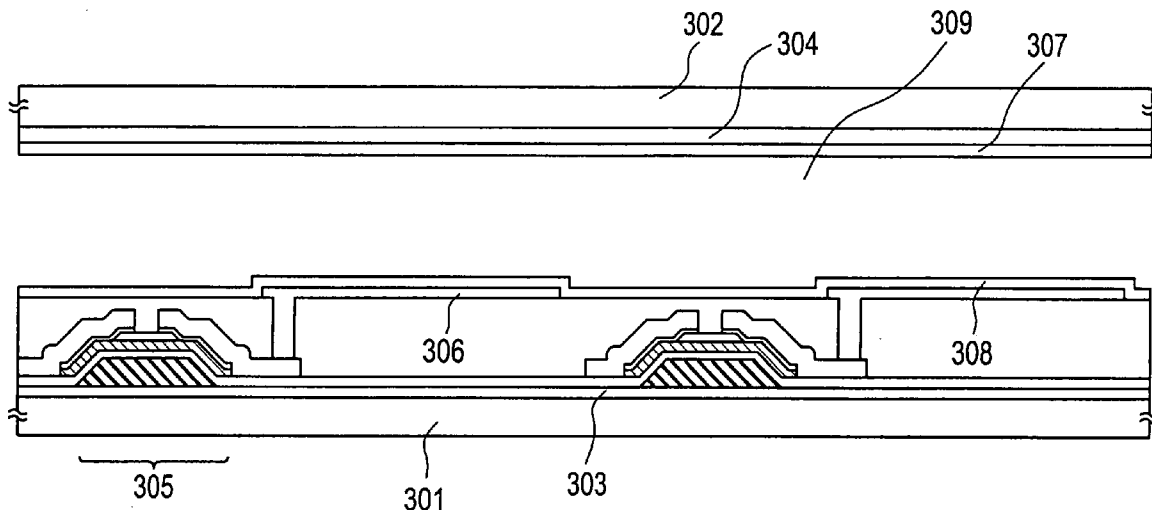

FIG. 1(A)

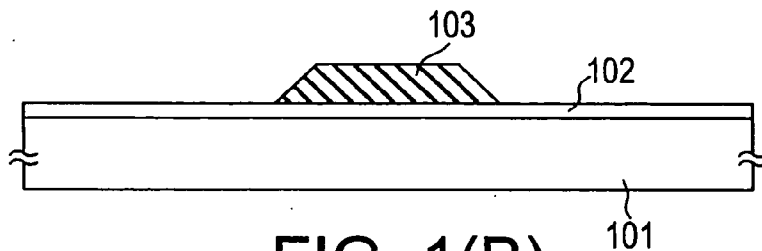

FIG. 1(B)

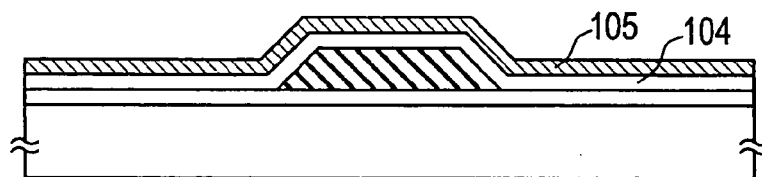

FIG. 1(C)

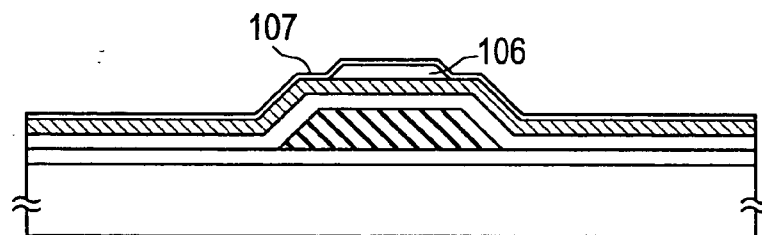

FIG. 1(D)

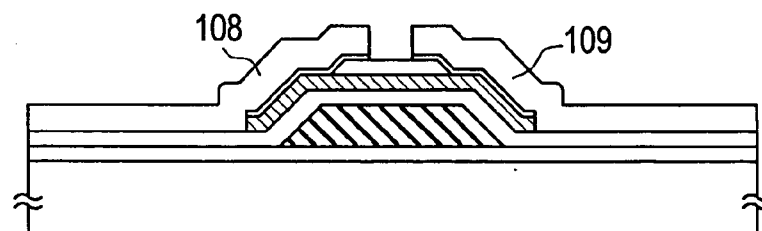
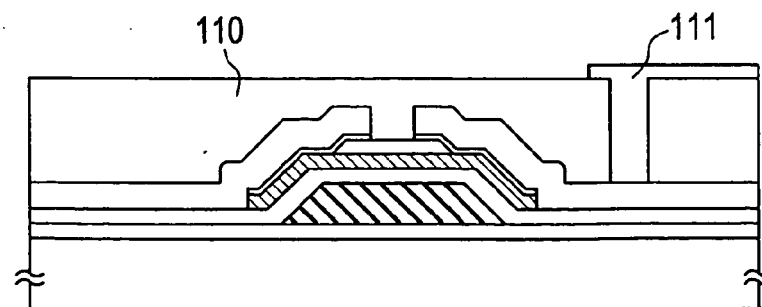
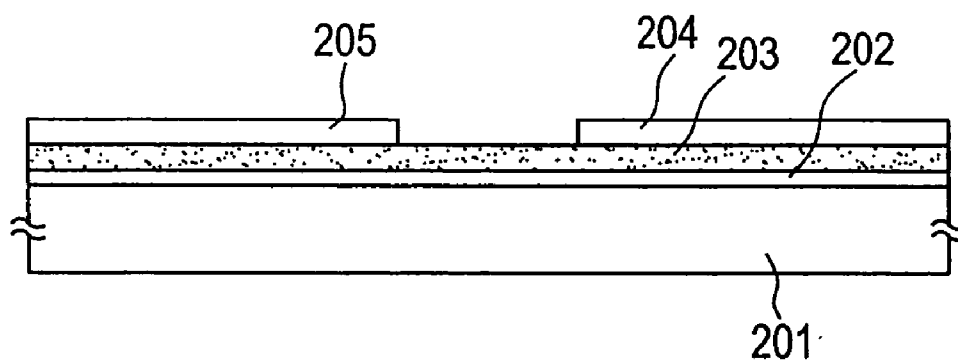

FIG. 1(E)



# FIG. 2(A)



# FIG. 2(B)

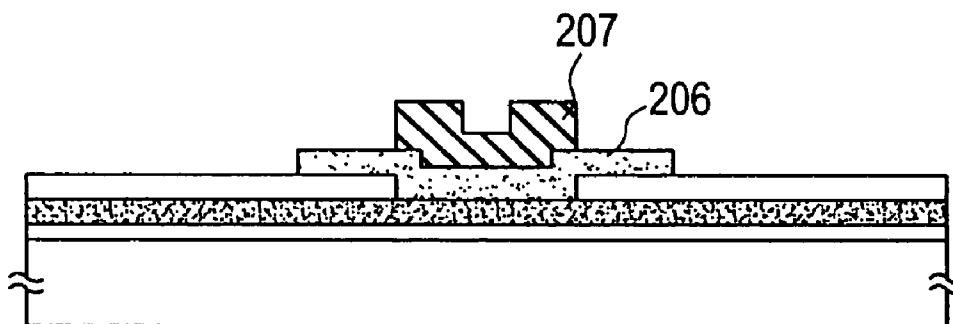

# FIG. 2(C)

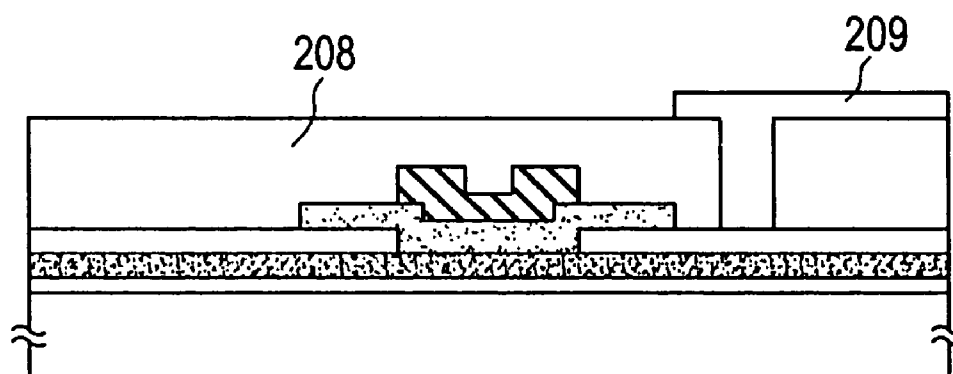
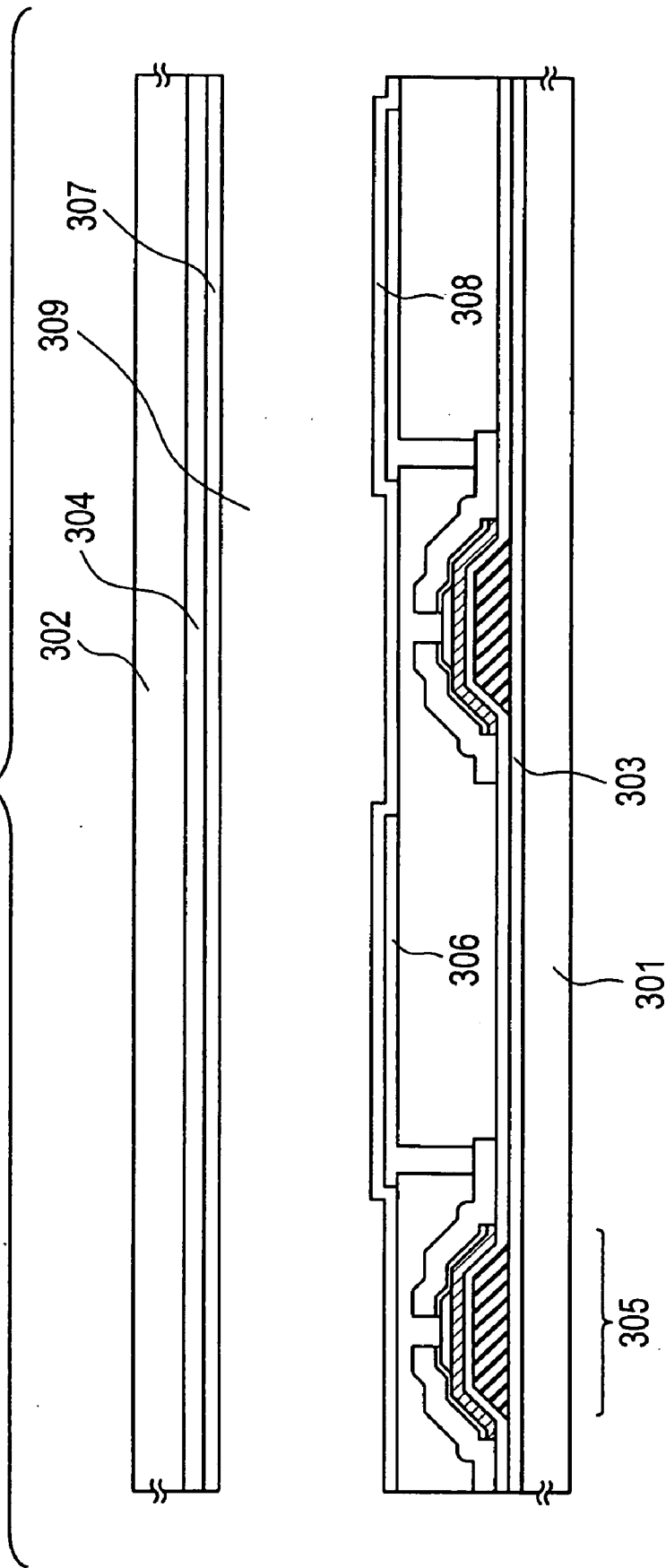

FIG. (3)



**SEMICONDUCTOR DEVICE, METHOD OF  
FABRICATING SAME, AND, ELECTROOPTICAL  
DEVICE**

BACKGROUND OF THE INVENTION

**[0001]** 1. Field of the Invention

**[0002]** The present invention relates to a configuration of thin-film transistors (TFTs) formed on a flexible substrate (i.e., having mechanical flexibility) such as a resinous substrate which can be made of engineering plastics. The invention also relates to a method of fabricating such thin-film transistors. Furthermore, the invention relates to an active matrix liquid crystal display fabricated, using these thin-film transistors.

**[0003]** 2. Prior Art

**[0004]** Thin-film transistors formed on glass substrates or on quartz substrates are known. Thin-film transistors formed on glass substrates are chiefly used in active matrix liquid crystal displays. Since active matrix liquid crystal displays can display images with high response and with high information content, it is expected that they can supplant simple matrix liquid crystal displays.

**[0005]** In an active matrix liquid crystal display, one or more thin-film transistors are disposed as a switching element at each pixel. Electric charge going in and out of the pixel electrode is controlled by this thin-film transistor. The substrates are made of glass or quartz, because it is necessary that visible light pass through the liquid crystal display.

**[0006]** Liquid crystal displays are display means which are expected to find quite extensive application. For example, they are expected to be used as display means for card-type computers, portable computers, and portable electronic devices for various telecommunication appliances. As more sophisticated information is treated, more sophisticated information is required to be displayed on the display means used for these portable electronic devices. For example, there is a demand for functions of displaying higher information content and moving pictures as well as numerals and symbols.

**[0007]** Where a liquid crystal display is required to have a function of displaying higher information content and moving pictures, it is necessary to utilize an active matrix liquid crystal display. However, where substrates made of glass or quartz are used, various problems take place: (1) limitations are imposed on thinning of the liquid crystal display itself; (2) the weight is increased; (3) if the thickness is reduced in an attempt to reduce the weight, the substrate breaks; and (4) the substrate lacks flexibility.

**[0008]** Especially, card-type electronic devices are required to be so flexible that they are not damaged if slight stress is exerted on them when they are treated. Therefore, liquid crystal displays incorporated in these electronic devices are similarly required to be flexible.

**[0009]** The invention disclosed herein provides an active matrix liquid crystal display having flexibility.

SUMMARY OF THE INVENTION

**[0010]** One available method of imparting flexibility to a liquid crystal display is to use plastic or resinous substrates

which transmit light. However, because of poor heat resistance of resinous substrates, it is technically difficult to form thin-film transistors on them.

**[0011]** Accordingly, the invention disclosed herein solves the foregoing difficulty by adopting the following configuration:

**[0012]** One invention disclosed herein comprises: a filmy resinous substrate; a resinous layer formed on a surface of said resinous substrate; and thin-film transistors formed on said resinous layer.

**[0013]** A specific example of the above-described configuration is shown in **FIG. 1**. In the configuration shown in **FIG. 1**, a resinous layer **102** is in contact with a PET film **101** having a thickness of 100  $\mu\text{m}$ , the PET film being a filmy resinous substrate. Inverted-staggered thin-film transistors are formed on the resinous layer.

**[0014]** The material of the filmy resinous substrate can be selected from PET (polyethylene terephthalate), PEN (polyethylene naphthalate), PES (polyethylene sulfite), and polyimide. The requirements are flexibility and transparency. Preferably, the maximum temperature that the material can withstand is made as high as possible. If the heating temperature is elevated above 200° C., oligomers (polymers having diameters of about 1  $\mu\text{m}$ ) are generally deposited on the surface, or gases are produced. Therefore, it is quite difficult to form a semiconductor layer on the resinous substrate. Consequently, the material should have the highest possible processing temperature.

**[0015]** In the above-described structure, the resinous layer acts to planarize the surface of the resinous substrate. The planarization also serves to prevent precipitation of oligomers on the surface of the resinous substrate during steps involving heating such as the step for forming the semiconductor layer.

**[0016]** The material of this resinous layer can be selected from methyl esters of acrylic acid, ethyl esters of acrylic acid, butyl esters of acrylic acid, and 2-ethylhexyl esters of acrylic acid. Even if resinous substrates are used, this resinous layer can suppress the drawbacks with fabrication of the afore-mentioned thin-film transistors.

**[0017]** The configuration of another invention comprises the steps of: forming a resinous layer on a filmy resinous substrate; forming a semiconductor layer on said resinous layer by plasma-assisted CVD; and forming thin-film transistors, using said semiconductor layer.

**[0018]** The configuration of a further invention comprises the steps of: heat-treating a filmy resinous substrate at a given temperature to degas said resinous substrate; forming a resinous layer on the filmy resinous substrate; forming a semiconductor layer on said resinous substrate by plasma-assisted CVD; and forming thin-film transistors, using said semiconductor layer.

**[0019]** In the above-described structure, heat-treatment is made to degas the resinous substrate, in order to prevent escape of gases from the resinous substrate during later processes involving heating. For example, if gases are released from the resinous substrate when a semiconductor thin film is being formed on the resinous substrate, then large pinholes are formed in the semiconductor thin film. This greatly impairs the electrical characteristics. Accordingly,

the substrate is heat-treated at a temperature higher than heating temperatures used in the later processes, to degas the resinous substrate. In this way, release of gases from the resinous substrate during the later steps can be suppressed.

[0020] The configuration of a yet other invention comprises the steps of: heat-treating a filmy resinous substrate at a given temperature; forming a resinous layer on said filmy resinous substrate; forming a semiconductor layer on said resinous substrate by plasma-assisted CVD while heating the substrate to a temperature lower than said given temperature; and forming thin-film transistors, using said semiconductor layer.

[0021] The configuration of a still other invention comprises the steps of: heat-treating a filmy resinous substrate at a given temperature which is higher than any heat-treatment temperature used in other steps; forming a resinous layer on said filmy resinous substrate; forming a semiconductor layer on said resinous substrate by plasma-assisted CVD; and forming thin-film transistors, using said semiconductor layer.

[0022] The configuration of a still further invention comprises: a pair of filmy resinous substrates; a liquid crystal material held between said resinous substrates; pixel electrodes formed on a surface of at least one of said resinous substrates; thin-film transistors connected with said pixel electrodes and formed on said resinous substrate; and resinous layers formed on surfaces of said filmy resinous substrates to planarize the surfaces.

[0023] A specific example of the above-described structure is shown in FIG. 3. In the structure shown in FIG. 3, a pair of resinous substrates 301, 302, a liquid crystal material 309 held between these resinous substrates, pixel electrodes 306, thin-film transistors (TFTs) 305 connected with the pixel electrodes 306, and a resinous layer 303 for planarizing the surface of the resinous substrate 301.

#### BRIEF DESCRIPTION OF THE DRAWINGS

[0024] FIGS. 1(A) to 1(E) are views illustrating a process sequence for fabricating thin-film transistors according to the present invention;

[0025] FIGS. 2(A) to 2(C) are views illustrating another process sequence for fabricating thin-film transistors according to the present invention; and

[0026] FIG. 3 is a schematic cross-sectional view of a liquid crystal panel.

#### DETAILED DESCRIPTION OF THE PREFERRED EMBODIMENTS

##### EXAMPLE 1

[0027] The present example shows an example in which inverted-staggered TFTs are formed on a substrate of PET (polyethylene terephthalate) which is an organic resin.

[0028] As shown in FIG. 1(A), a PET film 101 having a thickness of 100  $\mu\text{m}$  is first prepared and heat-treated to degas the film. This heat-treatment is required to be conducted at a temperature higher than the highest temperature applied in later processes. In the processes shown in the present example, a temperature of 160° C. used during formation of an amorphous silicon film by plasma-assisted

CVD is the highest heating temperature. Therefore, the heat-treatment for degassing the PET film is performed at 180° C.

[0029] A layer of an acrylic resin 102 is formed on this PET film 101. As an example, a methyl ester of acrylic acid can be used as the acrylic resin. This acrylic resin layer 102 acts to prevent precipitation of oligomers on the surface of the PET film 101 in processes conducted later. The acrylic resin layer 102 also serves to planarize the uneven surface of the PET film 102. Generally, PET film surface has unevenness of the order of several hundreds of angstroms to 1  $\mu\text{m}$ . Such unevenness greatly affects the electrical properties of the semiconductor layer having a thickness of several hundreds of angstroms. Therefore, it is quite important to planarize the base on which the semiconductor layer is formed.

[0030] Then, gate electrodes 103 of aluminum are formed. The gate electrodes 103 are formed by forming an aluminum film to a thickness of 2000 to 5000 Å (3000 Å in this example) by sputtering and performing a well-known patterning step making use of photolithography. The gate electrodes 103 are etched so that the side surfaces are tapered (FIG. 1(A)).

[0031] Thereafter, a silicon oxide film acting as a gate-insulating film 104 is formed to a thickness of 1000 Å by sputtering. The gate-insulating film 104 may be made from silicon nitride instead of silicon oxide.

[0032] Subsequently, a substantially intrinsic (I-type) amorphous silicon film 105 is formed to a thickness of 500 Å by plasma-assisted CVD under the following conditions:

film formation temperature (at which the substrate is heated):	160° C.
reaction pressure:	0.5 torr
RF power (13.56 MHz):	20 mW/cm <sup>2</sup>
reactant gas:	SiH <sub>4</sub>

[0033] In this example, the film is formed, using a parallel-plate plasma-CVD machine. The substrate is heated by a heater disposed within a substrate stage in which the resinous substrate is placed. In this way, the state shown in FIG. 1(B) is obtained.

[0034] Then, a silicon oxide film which acts as an etch stopper in a later step is formed by sputtering and then patterned to form an etch stopper 106.

[0035] Thereafter, an n-type amorphous silicon film 107 is formed to a thickness of 300 Å by parallel-plate plasma-assisted CVD under the following conditions:

film formation temperature (at which the substrate is heated):	160° C.
reaction pressure:	0.5 torr
RF power (13.56 MHz):	20 mW/cm <sup>2</sup>
reactant gases:	B <sub>2</sub> H <sub>6</sub> /SiH <sub>4</sub> = 1/100

[0036] In this way, the state shown in FIG. 1(C) is obtained. Then, the n-type amorphous silicon film 107 and the substantially intrinsic (I-type) amorphous silicon film

**105** are patterned by a dry-etching process. An aluminum film is formed to a thickness of 3000 Å by sputtering techniques. Thereafter, this aluminum film and the underlying n-type amorphous silicon film **107** are etched to form source electrodes **108** and drain electrodes **109**. During this etching process, the action of the etch stopper **106** assures that the source and drain regions are isolated from each other (**FIG. 1(D)**).

[**0037**] An interlayer dielectric layer **110** is formed out of a resinous material such as silicon oxide or polyimide to a thickness of 6000 Å. Where a silicon oxide film is formed, a liquid which is applied when the silicon oxide film is formed may be used. Finally, contact holes are formed, and pixel electrodes **111** are fabricated from ITO. In this way, thin-film transistors arranged at the pixel electrodes of the active matrix liquid crystal display can be fabricated, using the transparent resinous substrate (**FIG. 1(E)**).

#### EXAMPLE 2

[**0038**] The present example shows a case in which an active matrix liquid crystal display is fabricated, using the thin-film transistors described in Example 1. The liquid crystal electrooptical device described in the present example is shown in **FIG. 3** in cross section.

[**0039**] In **FIG. 3**, PET films **301** and **302** having a thickness of 100 μm form a pair of substrates. An acrylic resin layer **303** acts as a planarizing layer. Indicated by **306** are pixel electrodes. In **FIG. 3**, only the structure corresponding to two pixels is shown.

[**0040**] Indicated by **304** is a counter electrode. Orientation films **307** and **308** orient a liquid crystal **309** which can be a twisted-nematic (TN) liquid crystal, supertwisted-nematic (STN) liquid crystal, or a ferroelectric liquid crystal. Generally, a TN liquid crystal is employed. The thickness of the liquid crystal layer is several micrometers to about 10 μm.

[**0041**] Thin-film transistors (TFTs) **305** are connected with the pixel electrodes **306**. Electric charge going in and out of the pixel electrodes **306** is controlled by the TFTs **305**. In this example, only one of the pixel electrodes **306** is shown as a typical one but a required number of other configurations of similar structure are also formed.

[**0042**] In the structure shown in **FIG. 3**, the substrates **301** and **302** have flexibility and so the whole liquid crystal panel can be made flexible.

#### EXAMPLE 3

[**0043**] The present example shows an example in which coplanar thin-film transistors used for an active matrix liquid crystal display are fabricated. The process sequence for fabricating the thin-film transistors of the present example is shown in **FIG. 2**. First, a PET film **201** having a thickness of 100 μm is prepared as a filmy organic resin substrate. The film is heated-treated at 180° C. to promote degassing from the PET film **201**. A layer of an acrylic resin **202** is formed on the surface of the film. In this example, an ethyl ester of acrylic acid is used as the acrylic resin.

[**0044**] Then, a substantially intrinsic (I-type) semiconductor layer **203** in which a channel formation region is formed is grown by plasma-assisted CVD under the following conditions:

film formation temperature (at which the substrate is heated):	160° C.
reaction pressure:	0.5 torr
RF power (13.56 MHz):	20 mW/cm <sup>2</sup>
reactant gas:	SiH <sub>4</sub>

[**0045**] In this example, a parallel-plate plasma-CVD machine is used to grow the film.

[**0046**] Then, an n-type amorphous silicon film is grown to a thickness of 300 Å by the parallel-plate plasma-CVD machine under the following conditions:

film formation temperature (at which the substrate is heated):	160° C.
reaction pressure:	0.5 torr
RF power (13.56 MHz):	20 mW/cm <sup>2</sup>
reactant gases:	B <sub>2</sub> H <sub>6</sub> /SiH <sub>4</sub> = 1/100

[**0047**] The n-type amorphous silicon film is patterned to form source regions **205** and drain regions **204** (**FIG. 2(A)**).

[**0048**] A silicon oxide film or silicon nitride film acting as a gate-insulating film is formed by sputtering techniques and patterned to form the gate-insulating film **206**. Gate electrodes **207** are then formed from aluminum (**FIG. 2(B)**).

[**0049**] A polyimide layer **208** is formed as an interlayer dielectric film to a thickness of 5000 Å. Contact holes are formed. ITO electrodes **209** becoming pixel electrodes are formed by sputtering, thus completing TFTs (**FIG. 2(C)**).

#### EXAMPLE 4

[**0050**] The present example is similar to the structure of Example 1 or 2 except that the semiconductor layer is made of a microcrystalline semiconductor film. First, a substantially intrinsic semiconductor layer is grown as the microcrystalline semiconductor layer under the following conditions:

film formation temperature (at which the substrate is heated):	160° C.
reaction pressure:	0.5 torr
RF power (13.56 MHz):	150 mW/cm <sup>2</sup>
reactant gases:	SiH <sub>4</sub> /H <sub>2</sub> = 1/30

[**0051**] In this example, a parallel-plate plasma-CVD machine is used to grow the film.

[**0052**] The conditions under which an n-type microcrystalline silicon film is grown are described below. Also in this case, a parallel-plate plasma-CVD machine is used.

film formation temperature (at which the substrate is heated):	160° C.
reaction pressure:	0.5 torr

-continued

RF power (13.56 MHz):	150 mW/cm <sup>2</sup>
reactant gases:	B <sub>2</sub> H <sub>6</sub> /SiH <sub>4</sub> = 1/100

[0053] Generally, a microcrystalline silicon film can be obtained by supplying power of 100 to 200 mW/cm<sup>2</sup>. In the case of the I-type semiconductor layer, desirable results are obtained by diluting silane with hydrogen by a factor of about 10 to 50, as well as by increasing the power. However, if the hydrogen dilution is made, the film growth rate drops.

## EXAMPLE 5

[0054] The present example relates to a method consisting of irradiating a silicon film with laser light having such a power that the filmy base or substrate is not heated, the silicon film having been formed by plasma-assisted CVD as described in the other examples.

[0055] A technique for changing an amorphous silicon film formed on a glass substrate into a crystalline silicon film by irradiating the amorphous film with laser light (e.g., KrF excimer laser light) is known. In another known technique, impurity ions for imparting one conductivity type are implanted into the silicon film and then the silicon film is irradiated with laser light to activate the silicon film and the impurity ions. The implantation of the impurity ions amorphizes the silicon film.

[0056] The configuration described in the present example makes use of a laser irradiation process as described above, and is characterized in that the amorphous silicon film **105** shown in **FIG. 1** or the amorphous silicon films **203** and **204** shown in **FIG. 2** are irradiated with quite weak laser light to crystallize the amorphous silicon film. If the previously formed film is a microcrystalline silicon film, the crystallinity can be improved.

[0057] KrF excimer laser or XeCl excimer laser can be used to emit the laser light. The energy of the emitted laser light is 10 to 50 mJ/cm<sup>2</sup>. It is important that the resinous substrate **101** or **102** be not thermally damaged.

[0058] By utilizing the invention disclosed herein, the thickness of an active matrix liquid crystal display can be reduced. Also, the weight can be decreased. If an external force is applied, the substrates do not break. Flexibility can be imparted to the display.

[0059] This liquid crystal display can find wide application and is quite useful.

What is claimed is:

1. An electronic device comprising:

a panel having a thin film transistor formed over a substrate, the thin film transistor comprising:

a gate electrode formed over the substrate;

a gate insulating film formed over the gate electrode;

a substantially intrinsic semiconductor layer formed over the gate insulating film;

an n-type semiconductor layer formed over the substantially intrinsic semiconductor layer;

at least one of a source and a drain electrodes formed over the n-type semiconductor layer;

an insulating film comprising a resinous material formed over the thin film transistor, wherein the insulating film is not in contact with the substantially intrinsic semiconductor layer; and

a pixel electrode formed over the insulating film, wherein the pixel electrode is in contact with the at least one of the source and the drain electrodes.

2. An electronic device comprising:

a panel having a thin film transistor formed over a substrate, the thin film transistor comprising:

a gate electrode formed over the substrate;

a gate insulating film formed over the gate electrode;

a substantially intrinsic semiconductor layer formed over the gate insulating film;

an n-type semiconductor layer formed over the substantially intrinsic semiconductor layer;

at least one of a source and a drain electrodes formed over the n-type semiconductor layer, wherein an edge of the at least one of the source and the drain electrodes is aligned with an edge of the n-type semiconductor layer;

an insulating film comprising a resinous material formed over the thin film transistor, wherein the insulating film is not in contact with the substantially intrinsic semiconductor layer; and

a pixel electrode formed over the insulating film, wherein the pixel electrode is in contact with the at least one of the source and the drain electrodes.

3. An electronic device comprising:

a panel having a thin film transistor formed over a substrate, the thin film transistor comprising:

a gate electrode formed over the substrate;

a gate insulating film formed over the gate electrode;

a substantially intrinsic semiconductor layer formed over the gate insulating film;

an n-type semiconductor layer formed over the substantially intrinsic semiconductor layer;

at least one of a source and a drain electrodes formed over the n-type semiconductor layer;

an insulating film comprising a resinous material formed over the thin film transistor, wherein the insulating film is not in contact with the substantially intrinsic semiconductor layer; and

a pixel electrode formed over the insulating film, wherein the pixel electrode is in contact with the at least one of the source and the drain electrodes, and wherein a contact portion between the pixel electrode and the at least one of the source and the drain electrodes is not formed over the n-type semiconductor layer.

4. An electronic device comprising:

a panel having a thin film transistor formed over a substrate, the thin film transistor comprising:

a gate electrode formed over the substrate;



an n-type semiconductor layer formed over the substantially intrinsic semiconductor layer;

at least one of a source and a drain electrodes formed over the n-type semiconductor layer;

an insulating film comprising a resinous material formed over the thin film transistor, wherein the insulating film is not in contact with the substantially intrinsic semiconductor layer, and wherein the insulating film is in contact with an edge of the n-type semiconductor layer; and

a pixel electrode formed over the insulating film, wherein the pixel electrode is in contact with the at least one of the source and the drain electrodes, and wherein a contact portion between the pixel electrode and the at least one of the source and the drain electrodes is not formed over the n-type semiconductor layer.

**10.** An electronic device comprising:

a panel having a thin film transistor formed over a substrate, the thin film transistor comprising:

a gate electrode formed over the substrate;

a gate insulating film formed over the gate electrode;

a substantially intrinsic semiconductor layer formed over the gate insulating film;

an n-type semiconductor layer formed over the substantially intrinsic semiconductor layer;

at least one of a source and a drain electrodes formed over the n-type semiconductor layer;

an insulating film comprising a resinous material formed over the thin film transistor, wherein the insulating film is not in contact with the substantially intrinsic semiconductor layer, and wherein the insulating film is in contact with the gate insulating film; and

a pixel electrode formed over the insulating film, wherein the pixel electrode is in contact with the at least one of the source and the drain electrodes, and wherein a contact portion between the pixel electrode and the at least one of the source and the drain electrodes is not formed over the n-type semiconductor layer.

**11.** An electronic device comprising:

a panel having a thin film transistor formed over a substrate, the thin film transistor comprising:

a gate electrode formed over the substrate;

a gate insulating film formed over the gate electrode;

a substantially intrinsic semiconductor layer formed over the gate insulating film;

an n-type semiconductor layer formed over the substantially intrinsic semiconductor layer;

at least one of a source and a drain electrodes formed over the n-type semiconductor layer;

an insulating film comprising a resinous material formed over the thin film transistor, wherein the insulating film is not in contact with the substantially intrinsic semiconductor layer, wherein the insulating film is in con-

tact with an edge of the n-type semiconductor layer, and wherein the insulating film is in contact with the gate insulating film; and

a pixel electrode formed over the insulating film, wherein the pixel electrode is in contact with the at least one of the source and the drain electrodes.

**12.** An electronic device according to any one of claims 1-11, wherein the substrate comprises one selected from the group consisting of polyethylene terephthalate, polyethylene naphthalate, polyethylene sulfite, and polyimide.

**13.** An electronic device according to any one of claims 1-11, wherein the gate insulating film comprises silicon oxide or silicon nitride.

**14.** An electronic device according to any one of claims 1-11, wherein the substantially intrinsic semiconductor layer comprises amorphous silicon or microcrystalline silicon.

**15.** An electronic device according to any one of claims 1-11, wherein the at least one of the source and the drain electrodes comprises aluminum.

**16.** An electronic device according to any one of claims 1-11, wherein the insulating film comprising the resinous material comprises polyimide.

**17.** An electronic device according to any one of claims 1-11, wherein the pixel electrode comprises ITO.

**18.** A computer comprising:

a panel having a thin film transistor formed over a substrate, the thin film transistor comprising:

a gate electrode formed over the substrate;

a gate insulating film formed over the gate electrode;

a substantially intrinsic semiconductor layer formed over the gate insulating film;

an n-type semiconductor layer formed over the substantially intrinsic semiconductor layer;

at least one of a source and a drain electrodes formed over the n-type semiconductor layer;

an insulating film comprising a resinous material formed over the thin film transistor, wherein the insulating film is not in contact with the substantially intrinsic semiconductor layer; and

a pixel electrode formed over the insulating film, wherein the pixel electrode is in contact with the at least one of the source and the drain electrodes.

**19.** A computer comprising:

a panel having a thin film transistor formed over a substrate, the thin film transistor comprising:

a gate electrode formed over the substrate;

a gate insulating film formed over the gate electrode;

a substantially intrinsic semiconductor layer formed over the gate insulating film;

an n-type semiconductor layer formed over the substantially intrinsic semiconductor layer;

at least one of a source and a drain electrodes formed over the n-type semiconductor layer, wherein an edge of the at least one of the source and the drain electrodes is aligned with an edge of the n-type semiconductor layer;



conductor layer, and wherein the insulating film is in contact with an edge of the n-type semiconductor layer; and

a pixel electrode formed over the insulating film, wherein the pixel electrode is in contact with the at least one of the source and the drain electrodes.

**25.** A computer comprising:

a panel having a thin film transistor formed over a substrate, the thin film transistor comprising:

a gate electrode formed over the substrate;

a gate insulating film formed over the gate electrode;

a substantially intrinsic semiconductor layer formed over the gate insulating film;

an n-type semiconductor layer formed over the substantially intrinsic semiconductor layer;

at least one of a source and a drain electrodes formed over the n-type semiconductor layer, wherein an edge of the at least one of the source and the drain electrodes is aligned with an edge of the n-type semiconductor layer;

an insulating film comprising a resinous material formed over the thin film transistor, wherein the insulating film is not in contact with the substantially intrinsic semiconductor layer, and wherein the insulating film is in contact with the gate insulating film; and

a pixel electrode formed over the insulating film, wherein the pixel electrode is in contact with the at least one of the source and the drain electrodes.

**26.** A computer comprising:

a panel having a thin film transistor formed over a substrate, the thin film transistor comprising:

a gate electrode formed over the substrate;

a gate insulating film formed over the gate electrode;

a substantially intrinsic semiconductor layer formed over the gate insulating film;

an n-type semiconductor layer formed over the substantially intrinsic semiconductor layer;

at least one of a source and a drain electrodes formed over the n-type semiconductor layer;

an insulating film comprising a resinous material formed over the thin film transistor, wherein the insulating film is not in contact with the substantially intrinsic semiconductor layer, and wherein the insulating film is in contact with an edge of the n-type semiconductor layer; and

a pixel electrode formed over the insulating film, wherein the pixel electrode is in contact with the at least one of the source and the drain electrodes, and wherein a contact portion between the pixel electrode and the at least one of the source and the drain electrodes is not formed over the n-type semiconductor layer.

**27.** A computer comprising:

a panel having a thin film transistor formed over a substrate, the thin film transistor comprising:

a gate electrode formed over the substrate;

a gate insulating film formed over the gate electrode;

a substantially intrinsic semiconductor layer formed over the gate insulating film;

an n-type semiconductor layer formed over the substantially intrinsic semiconductor layer;

at least one of a source and a drain electrodes formed over the n-type semiconductor layer;

an insulating film comprising a resinous material formed over the thin film transistor, wherein the insulating film is not in contact with the substantially intrinsic semiconductor layer, and wherein the insulating film is in contact with the gate insulating film; and

a pixel electrode formed over the insulating film, wherein the pixel electrode is in contact with the at least one of the source and the drain electrodes, and wherein a contact portion between the pixel electrode and the at least one of the source and the drain electrodes is not formed over the n-type semiconductor layer.

**28.** A computer comprising:

a panel having a thin film transistor formed over a substrate, the thin film transistor comprising:

a gate electrode formed over the substrate;

a gate insulating film formed over the gate electrode;

a substantially intrinsic semiconductor layer formed over the gate insulating film;

an n-type semiconductor layer formed over the substantially intrinsic semiconductor layer;

at least one of a source and a drain electrodes formed over the n-type semiconductor layer;

an insulating film comprising a resinous material formed over the thin film transistor, wherein the insulating film is not in contact with the substantially intrinsic semiconductor layer, wherein the insulating film is in contact with an edge of the n-type semiconductor layer, and wherein the insulating film is in contact with the gate insulating film; and

a pixel electrode formed over the insulating film, wherein the pixel electrode is in contact with the at least one of the source and the drain electrodes.

**29.** A computer according to any one of claims **18-28**, wherein the substrate comprises one selected from the group consisting of polyethylene terephthalate, polyethylene naphthalate, polyethylene sulfite, and polyimide.

**30.** A computer according to any one of claims **18-28**, wherein the gate insulating film comprises silicon oxide or silicon nitride.

**31.** A computer according to any one of claims **18-28**, wherein the substantially intrinsic semiconductor layer comprises amorphous silicon or microcrystalline silicon.

**32.** A computer according to any one of claims **18-28**, wherein the at least one of the source and the drain electrodes comprises aluminum.

**33.** A computer according to any one of claims **18-28**, wherein the insulating film comprising the resinous material comprises polyimide.

**34.** A computer according to any one of claims **18-28**, wherein the pixel electrode comprises ITO.