

C.H. Frisbie,

Exhaust Nozzle.

No. 103596.

Patented May 31. 1870.

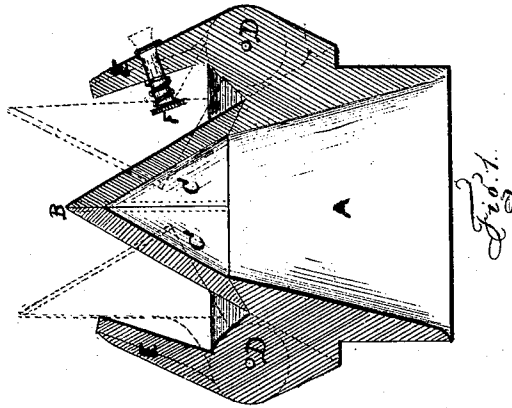
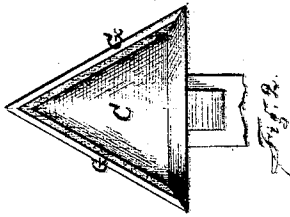

Witnesses:
G. H. Frost.
L. H. Farwell

Inventor.
C. H. Frisbie
By Farwell, Beerwath & Co,
Attorneys

United States Patent Office.

CHARLES H. FRISBIE, OF CHICAGO, ILLINOIS.

Letters Patent No. 103,596, dated May 31, 1870.

EXHAUST-NOZZLE.

The Schedule referred to in these Letters Patent and making part of the same.

To all whom it may concern :

Be it known that I, CHARLES H. FRISBIE, of Chicago, in the county of Cook and State of Illinois, have invented a new and useful Improvement in Exhaust-Nozzle for Steam-Engines; and I do hereby declare the following to be a full, clear, and exact description thereof, which will enable others skilled in the art to which my invention appertains to make and use the same, reference being had to the accompanying drawings forming part of this specification.

Figure 1 is a transverse vertical section of my improved exhaust-nozzle, and

Figure 2 is a detached view of one of the valves thereof.

Similar letters of reference indicate corresponding parts in the several figures of the drawings.

My invention has for its object to provide an automatic exhaust-nozzle to be attached to the exhaust-pipes of steam-engines to prevent ashes, cinders, hot air, &c., from entering the exhaust-pipes, to come in contact with the valve and its seat, or the piston and interior of the cylinder, and thereby injuring their working surfaces.

The invention consists in the automatic valves of peculiar construction, adapted to open by the action of exhaust steam directly into the smoke-box or stack of a locomotive engine, and to close by their own gravity when the exhaust has ceased.

In the accompanying drawings—

A is the cap or nozzle, adapted, by suitable means, for attachment to the end of an exhaust-pipe, arranged in a vertical position within the smoke-box or stack of a locomotive-engine.

B is the valve, consisting of a hollow cone divided longitudinally into two equal parts C C, each hinged to opposite sides of the cap A, and finding their seats upon the upper beveled end of said cap.

When the exhaust steam from the engine passes through the cap it lifts the valves C C outward in opposite directions, and escapes between them, and, when the pressure of the steam is relieved, the valves

close upon the cap by their own gravity to prevent the ashes, cinders, &c., from entering the exhaust-pipe, to come in contact with and cut out and injure the working surfaces of the cylinder, piston, and steam-valve of the engine.

The projections D which contain the hinges of the valves C C, are also provided with vertical extensions E E for the purpose of preventing the valves from swinging outward beyond a vertical line, so that they shall close upon the cap A, when the exhaust has ceased, by their own gravity.

If desired, a spring, F, may be arranged in each of the extensions E, to assist the descent of the valves.

The proximate edges G of the valves are rebated, as shown, so that they shall fit snugly together when closed upon their seats, and their lower edges are beveled to correspond with their seats upon the cap.

The beveled end of the cap prevents cinders, ashes, &c., from lodging thereon when the valves are raised, while the latter, when closed, present an unbroken conical exterior, from which the ashes, &c., are depleted.

By constructing the valves with an interior conical surface, an increased area is produced for the action of the steam, and the valves are therefore rendered more sensitive and less liable to adhere to their seats.

I am aware that exhaust-nozzles have been made with valves, which, by the action of springs, are closed upon each other when the exhaust ceases; but they have not, to my knowledge, been closed by the force of their own gravity.

Having thus described my invention,

What I claim as new, and desire to secure by Letters Patent, is—

The hollow cone B, forming the two hinged valves C C, in combination with the nozzle or cap A, and extensions E, for the purpose specified.

CHARLES H. FRISBIE.

Witnesses:

E. A. ELLSWORTH,
G. H. FROST.