

E. P. WINGREN.  
RAIL JOINT.

APPLICATION FILED MAY 9, 1903.

2 SHEETS—SHEET 1.

Fig: 1.

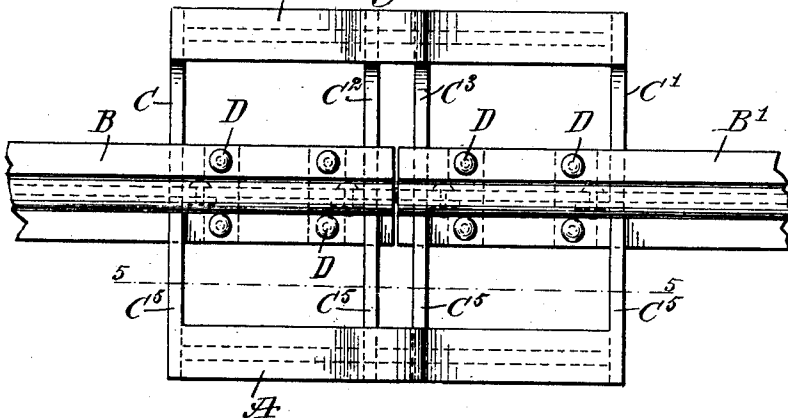

Fig: 2.

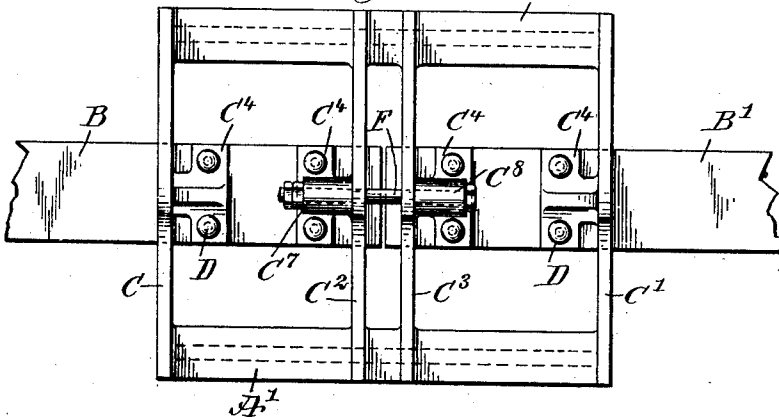
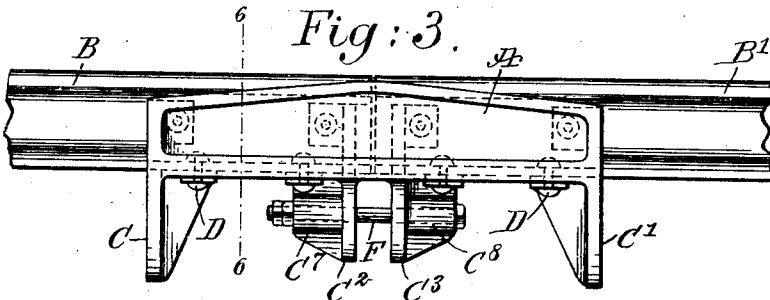

Fig: 3.



WITNESSES  
*J. Mumblak*  
*Henry H. Hovden*

INVENTOR  
*Eric Peter Wingren*  
 BY *Mumblak*  
 ATTORNEYS

E. P. WINGREN.  
RAIL JOINT.  
APPLICATION FILED MAY 9, 1906.

Fig: 4.

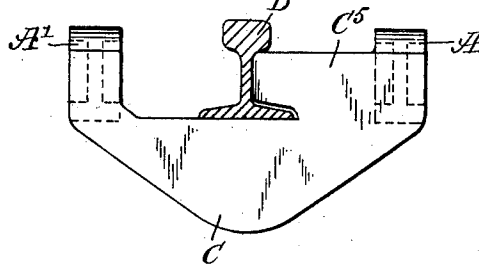

Fig: 5.

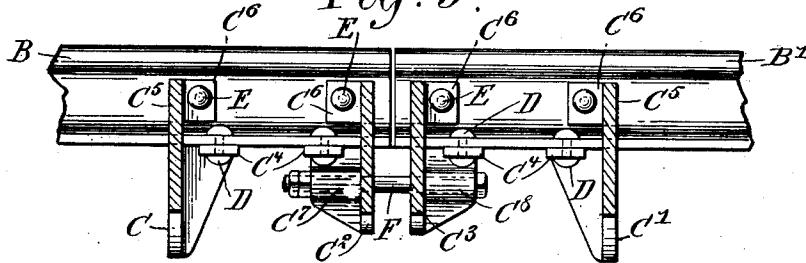

Fig: 6.

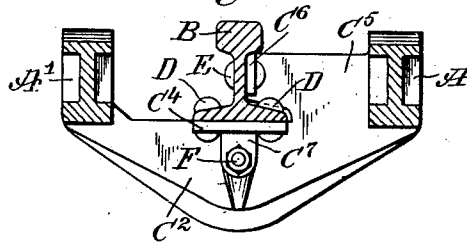
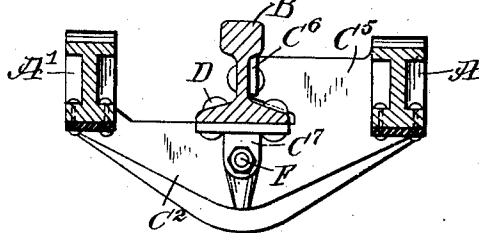

Fig: 7.



WITNESSES  
*J. Missblatt*  
*Henry M. Foster*

INVENTOR  
*Eric Peter Wingren*  
BY *Munn & Co*  
ATTORNEYS

# UNITED STATES PATENT OFFICE.

ERIC PETER WINGREN, OF DENISON, TEXAS.

## RAIL-JOINT.

No. 826,812.

Specification of Letters Patent.

Patented July 24, 1906.

Application filed May 9, 1906. Serial No. 315,945.

*To all whom it may concern:*

Be it known that I, ERIC PETER WINGREN, a citizen of the United States, and a resident of Denison, in the county of Grayson and State of Texas, have invented a new and Improved Rail-Joint, of which the following is a full, clear, and exact description.

The invention relates to railway construction; and its object is to provide a new and improved rail-joint arranged to securely unite the meeting ends of adjacent rails with each other to allow expansion and contraction of the rails without their sliding on the joint, thus preventing wear, to insure lateral alinement of the rails, to effectively resist the flange thrust on curves, and to allow the convenient use of the device on steam and electric railways.

The invention consists of novel features and parts and combinations of the same, which will be more fully described hereinafter and then pointed out in the claims.

A practical embodiment of the invention is represented in the accompanying drawings, forming a part of this specification, in which similar characters of reference indicate corresponding parts in all the views.

Figure 1 is a plan view of the improvement as applied. Fig. 2 is an inverted plan view of the same. Fig. 3 is a side elevation of the same. Fig. 4 is an end view of the same. Fig. 5 is a sectional-side elevation of the same on the line 5 5 of Fig. 1. Fig. 6 is a transverse section of the same on the line 6 6 of Fig. 3, and Fig. 7 is a like view of a modified form of the improvement.

The longitudinally-extending girders A A' are arranged on opposite sides of the rails B and B', to be fastened together by the device, and the said girders A A' are connected with each other by transverse members C, C', C<sup>2</sup>, and C<sup>3</sup> in the form of vertically-disposed plates capable of flexing, the plates being provided at or near their middle with flanges C<sup>4</sup>, fastened by bolts, rivets, or other fastening devices D to the bases of the rails B and B'. Thus by the arrangement described the members C, C', C<sup>2</sup>, and C<sup>3</sup> form seats for the bases of the rails B and B', and as the latter are rigidly secured to the said members C, C', C<sup>2</sup>, and C<sup>3</sup> it is evident that any expansion and contraction of the rails causes corresponding flexing of the members C, C', C<sup>2</sup>, and C<sup>3</sup> without danger, however, of disuniting the connected parts. As illustrated in Figs. 1 to 6, the members C, C', C<sup>2</sup>, and C<sup>3</sup>

form integral parts of the girders A A'—that is, the said parts constitute a frame, preferably made of steel—but, if desired, the members C, C', C<sup>2</sup>, and C<sup>3</sup> may be fastened by bolts, rivets, or other suitable fastening devices to the girders A and A', and the members C, C', C<sup>2</sup>, and C<sup>3</sup> are insulated from the girders by suitable insulating-plates, as illustrated in Fig. 7. Now this construction is especially designed for use on railways using block-signals or any other signaling apparatus requiring occasional insulation of two adjoining rails. If, however, a perfect electrical connection from one rail to another is desired, the rails B B' are welded to the members C<sup>4</sup> either electrically or by a thermit or other process, so that a perfect electrical connection from rail to rail is obtained without the use of the copper bonds now generally employed, and at the same time the joint allows expansion and contraction of the rails by the flexing of the members C, C', C<sup>2</sup>, and C<sup>3</sup>.

In order to insure longitudinal alinement of the rails B B' and to form a rail-brace to resist the flange thrust on curves, the members C, C', C<sup>2</sup>, and C<sup>3</sup> are provided with upwardly-extending integral extensions C<sup>5</sup>, having flanges C<sup>6</sup> at their inner ends secured by bolts, rivets, or other fastening devices E to the webs of the rails B and B'. By reference to the drawings it will be seen that the extensions C<sup>5</sup> only engage the webs of the rails at one side thereof, it being understood that by this construction the rails can be conveniently placed on the rail-joint when laying the track.

In order to limit the flexing movement of the members C<sup>2</sup> C<sup>3</sup>, the following device is provided. The members C<sup>2</sup> C<sup>3</sup> are provided below the bases of the rails B B' with bosses C<sup>7</sup> C<sup>8</sup>, engaged by a longitudinally-extending bolt F, arranged to allow the members C<sup>2</sup> C<sup>3</sup> to flex outwardly or from each other to a predetermined distance, but to prevent further outward flexing, thereby preventing the ends of the rails B B' from being pulled too far apart in case of creepage or other causes.

From the foregoing it will be seen that by a correct proportioning of the parts the device is equally as rigid as the rails, and as there is no wear and no possibility of its parts working loose it will remain in proper condition for a long time.

The device may be used in other structures in which it is desired to have a small longitudinal movement without sacrificing any

strength in a vertical plane, and hence I do not limit myself to the particular use of the device as shown and described.

Having thus described my invention, I claim as new and desire to secure by Letters Patent—

1. A rail-joint provided with a frame having transverse members capable of flexing and to which the rails are secured.
2. A rail-joint provided with a frame having transverse members capable of flexing and to which the rails are secured, the said members having extensions for engaging the rails at one side to insure longitudinal alinement of the rails.
3. A rail-joint, comprising girders spaced apart on opposite sides of the rails, transverse members connecting the girders with each other and forming a flexible seat for the bases of the rails, and fastening devices for securing the rail-bases to the said members.
4. A rail-joint, comprising girders spaced apart on opposite sides of the rails, transverse members connecting the girders with each other and forming a flexible seat for the bases of the rails, the said members having upward extensions for engaging the rails at one side to insure longitudinal alinement of the rails, and fastening devices for securing the rail-bases to the said members.
5. A rail-joint, comprising girders spaced apart on opposite sides of the rails, transverse members connecting the girders with each other and forming a flexible seat for the bases of the rails, the said members having upward extensions for engaging the rails at one side to insure longitudinal alinement of the rails, fastening devices for securing the rail-bases to the said members, and fastening devices for securing the said extensions to the webs of the rails.

6. A rail-joint provided with a frame having transverse members capable of flexing and to which the rails are secured, and means for limiting the flexing movement of the said members.

7. A rail-joint, comprising girders spaced apart on opposite sides of the rails, transverse members connecting the girders with each other and forming a flexible seat for the bases of the rails, fastening devices for securing the rail-bases to the said members, and means for limiting the flexing movement of the said members.

8. A rail-joint, comprising girders spaced apart on opposite sides of the rails, transverse members connecting the girders with each other and forming a flexible seat for the bases of the rails, two of the members having on opposite sides of the joint of the rails means for limiting the flexing movement of the said two members, and fastening devices for securing the said bases to the said members.

9. A rail-joint, comprising girders spaced apart on opposite sides of the rails, transverse members connecting the girders with each other and forming a flexible seat for the bases of the rails, bosses on the two members located on opposite sides of the joint of the rail, a bolt extending loosely through the said bosses in a longitudinal direction to limit the flexing movement of the said members, and fastening devices for securing the rail-bases to the said members.

In testimony whereof I have signed my name to this specification in the presence of two subscribing witnesses.

ERIC PETER WINGREN.

Witnesses:

NELSON G. CHAMBERLAIN,  
GEO. W. EMERSON.