



(11) **EP 3 525 614 B1**

(12) **EUROPEAN PATENT SPECIFICATION**

(45) Date of publication and mention of the grant of the patent:  
**18.08.2021 Bulletin 2021/33**

(21) Application number: **17780750.0**

(22) Date of filing: **09.10.2017**

(51) Int Cl.:  
**A45D 40/26 (2006.01)**

(86) International application number:  
**PCT/EP2017/075622**

(87) International publication number:  
**WO 2018/069217 (19.04.2018 Gazette 2018/16)**

(54) **TWO-PART WIPING DEVICE**

ZWEITEILIGE WISCHVORRICHTUNG

DISPOSITIF D'ESSUYAGE EN DEUX PARTIES

(84) Designated Contracting States:  
**AL AT BE BG CH CY CZ DE DK EE ES FI FR GB GR HR HU IE IS IT LI LT LU LV MC MK MT NL NO PL PT RO RS SE SI SK SM TR**

(30) Priority: **13.10.2016 FR 1659916**

(43) Date of publication of application:  
**21.08.2019 Bulletin 2019/34**

(73) Proprietor: **Société Industrielle de Matières Plastiques**  
**91250 Tigery (FR)**

(72) Inventors:  
• **DE BARDONNECHE, Eric**  
**91250 Tigery (FR)**  
• **DA COSTA, Antonio**  
**91250 Tigery (FR)**

(74) Representative: **Gauchet, Fabien Roland**  
**Brandon IP**  
**64, rue Tiquetonne**  
**75002 Paris (FR)**

(56) References cited:  
**EP-A1- 0 627 182 EP-A2- 1 561 394**  
**FR-A1- 2 679 113 FR-A1- 3 028 731**

**EP 3 525 614 B1**

Note: Within nine months of the publication of the mention of the grant of the European patent in the European Patent Bulletin, any person may give notice to the European Patent Office of opposition to that patent, in accordance with the Implementing Regulations. Notice of opposition shall not be deemed to have been filed until the opposition fee has been paid. (Art. 99(1) European Patent Convention).

## Description

**[0001]** The present invention relates to a device for packaging and applying a product, notably a cosmetic or care product, comprising a container containing the product to be applied and an applicator member that can be loaded with product by being dipped in the container.

**[0002]** Such devices are conventionally provided with a wiping device, also known as a wiper, that can be fastened to the neck of the container and makes it possible to wipe off the applicator member and the stem that carries it while they are being withdrawn from the container.

**[0003]** Various wiping devices have been proposed in order notably to adapt to the nature of the applicator member and the desired makeup result.

**[0004]** The choice of material from which the wiping device is made corresponds to a compromise between two contradictory requirements.

**[0005]** For the one part, the wiping device should be sufficiently rigid for the holding thereof in the neck to ensure satisfactory fastening. For the other part, the wiping device should be sufficiently flexible to be able to deform as the applicator member passes through.

**[0006]** Finally, the wiping device should also contribute, in some cases, to the leaktightness of the closure of the container.

**[0007]** In order to meet this problem, proposals have been made to produce the wiping device from several materials of different hardnesses.

**[0008]** Thus, the patent FR 3005835 describes a wiping device made up of two pieces of different rigidities, with a first piece provided with a wiping lip made from a material more flexible than the other piece, which serves for fastening in the neck. The two pieces are preassembled before the assembly is mounted in the neck of the container.

**[0009]** The more flexible piece has a mounting skirt fitted in an annular groove formed in the more rigid piece, the two pieces being held together by friction. The wiping device is positioned automatically.

**[0010]** Sometimes, the second piece, which is more flexible, moves relative to the first piece after preassembly and before fastening in the neck. The second piece can thus be poorly positioned after the assembly has been mounted in the neck, and this can compromise the immobilization thereof on the neck and the quality of wiping, or even cause a lack of leaktightness of the closure of the container.

**[0011]** The French patent application FR 2 679 113 discloses a wiping device comprising a wiping part and a part that serves for fastening the wiping device to the neck of the container.

**[0012]** The wiping part is configured to be fastened to the fastening part by snap-fastening.

**[0013]** This snap-fastening can take place before the fastening part is mounted on the container.

**[0014]** In one exemplary embodiment, a radial clearance is made around the region of the wiping part which

is snap-fastened to the fastening part.

**[0015]** The patent FR 2 865 911 likewise discloses a two-part wiping device, said two parts, in the final configuration thereof before fastening of the wiping device, being in the neck of the container.

**[0016]** The wiping part can be fastened to the fastening part with the aid of a relief such as a bulge or a groove present on the outer surface of the fastening part.

**[0017]** The patent application FR 2 855 380 discloses a similar two-part wiping device.

**[0018]** FR 3 028 731 discloses a wiping device comprising two detachable portions held integrally by means of cooperating reliefs.

**[0019]** EP 1 561 394 describes a similar wiping device comprising two assembled parts.

**[0020]** EP 0 627 182 discloses a wiping device consisting of two parts fixed to each other by a groove-bead system.

**[0021]** There is therefore a need to further improve wiping devices formed of several pieces, in order notably to ensure the reliability of mounting and the wiping performance during use of the packaging device and also the leaktightness of the closure of the container, if need be.

**[0022]** The invention aims to meet this need and achieves this, according to one of its aspects, by virtue of a device according to enclosed claim 1.

**[0023]** By virtue of the invention, the wiping part is fastened reliably to the fastening part from the preassembly phase, before mounting in the neck.

**[0024]** The possibility of preassembling the fastening part and wiping part before the assembly is mounted on the container makes it easier to handle the wiping device.

**[0025]** In particular, the latter can be positioned on the container in a single operation by being inserted into the neck of the container.

**[0026]** The fact that the outer skirt is deformed radially inward by the neck while the device is being mounted in the neck ensures reliable fastening of the wiping part in the container.

**[0027]** This firm hold of the wiping part on the fastening part can be carried out without otherwise making the two parts difficult to preassemble.

**[0028]** A satisfactory compromise between, for the one part, the ease of preassembly of the two parts and, for the other part, the reliability of the hold of the wiping part in the container is thus obtained on account of the strong mechanical hold of the assembly when the device is in position in the neck.

**[0029]** The invention also makes it possible, if desired, to use a relatively soft material, which is nevertheless securely fastened in the container on account of the abovementioned deformation of the outer skirt, in order to produce the wiping part.

**[0030]** In contrast to the wiping devices in which the two parts, once assembled before being positioned on the container, are in their final configuration, in the invention, there is deformation of the outer skirt between the preassembly configuration and the final configuration in

the neck of the container.

**[0031]** The deformation of the outer skirt can be accompanied by bending thereof at its base. Thus, the outer skirt can pivot slightly inward, further reinforcing the solidity of the assembly.

**[0032]** The deformation of the outer skirt can be carried out by said outer skirt pressing against the upper portion of the neck of the container, notably against a bevelled edge that delimits the opening of the neck radially toward the inside.

**[0033]** In the case of poor preassembly of the fastening part and wiping part, notably in the case of insufficient insertion of the wiping part into the fastening part, during mounting in the neck of the container, the deformation of the outer skirt can be impeded, thereby providing an easy means of detecting poor preassembly, since, in this case, the fastening part barely fits into the neck of the container, if at all.

**[0034]** Advantageously, said relief is formed by a protruding bulge on the inner surface of the outer skirt. This bulge makes it possible, during final assembly, to immobilize the mounting skirt in the fastening part by deformation of the outer skirt.

**[0035]** Preferably, the outer skirt has, between its free edge and said bulge, a groove that is open toward the mounting skirt.

**[0036]** Preferably, the mounting skirt has an angled region with an outside diameter which passes through a maximum at a distance from its free edge.

**[0037]** This angled region is preferably positioned axially between the bottom of the annular groove formed between the outer skirt and inner skirt and said relief. It is thus involved in retaining the wiping part on the fastening part.

**[0038]** According to one advantageous embodiment, the mounting skirt presses against the inner surface of the outer skirt above the angled region. This can help to immobilize the wiping part on the fastening part by jamming the outer skirt and mounting skirt.

**[0039]** The free edge of the mounting skirt is advantageously at a distance from the bottom of the annular groove formed between the inner skirt and the outer skirt.

**[0040]** Preferably, the inner skirt has a chamfer that presses against the mounting skirt, notably against a part of the mounting skirt that is situated between the angled region and the body of the wiping part. This can help to immobilize the mounting skirt in the groove formed between the outer skirt and inner skirt.

**[0041]** According to one advantageous feature, the inner skirt presses axially against a shoulder at the base of the mounting skirt. This allows the wiping part to be positioned precisely on the fastening part.

**[0042]** The outer skirt is preferably longer than the inner skirt.

**[0043]** The body of the wiping part may define, with the mounting skirt, an annular groove in the outer surface of the body.

**[0044]** The fastening part has a body that may be of

substantially cylindrical shape and is provided at its upper end with a flange.

**[0045]** Preferably, the fastening part is made from a harder material than the wiping part.

5 **[0046]** The fastening part may be made of a thermoplastic material of the PE or TPE type.

**[0047]** The wiping part may be made of an elastomer.

10 **[0048]** Advantageously, the body of the wiping part has a lower portion having at least one notch in its circumference, this allowing easy guidance and transport of the wiping part on the assembly line.

15 **[0049]** A further subject of the invention is a wiping part for a wiping device according to the invention, having a wiping lip for wiping off the stem and the applicator member of an applicator passed through the wiping device, the wiping lip being connected to a body surmounted by a mounting skirt on a fastening part that serves for holding the device in the neck of the container, said mounting skirt having an angled region that defines a largest outside diameter of the skirt.

20 **[0050]** A further subject of the invention, according to another of its aspects, is a method for mounting a wiping device on a container, comprising:

- 25 - the preassembly of the wiping part and the fastening part so as to immobilize the mounting skirt of the wiping part in the annular groove in the fastening part formed between the inner skirt and outer skirt thereof, and
- 30 - the introduction of the assembled assembly into the neck of the container so as to deform the mounting skirt as a result of the relief on the outer skirt pressing against the latter.

35 **[0051]** The invention may be better understood from reading the following detailed description of nonlimiting exemplary embodiments thereof and from examining the appended drawing, in which:

- 40 - Figure 1 schematically shows a perspective view of a packaging and application device produced in accordance with the invention, the applicator being shown withdrawn entirely from the container,
- Figure 2 shows, in axial section, the wiping device of the packaging device from figure 1 on its own,
- 45 - Figure 3 shows the detail III from figure 2,
- Figure 4 shows the lower and upper parts of the wiping device during preassembly,
- Figure 5 illustrates the detail V from figure 4,
- 50 - Figure 6 is a perspective view showing the upper part of the wiping device on its own,
- Figure 7 is an axial section through the upper part,
- Figure 8 shows a perspective view of the lower part on its own,
- 55 - Figure 9 is an axial section through the lower part,
- Figure 10 is a view similar to figure 4, following preassembly of the lower and upper parts before introduction into the neck of the container,

- Figure 11 shows the detail XI from figure 10,
- Figure 12 shows the wiping device during introduction into the neck,
- Figure 13 shows the wiping device following completion of introduction into the neck of the container,
- Figure 14 shows the detail XIV from figure 13, and
- Figures 15 and 16 are views similar to figures 8 and 9, respectively, of a variant embodiment of the lower part of the wiping device.

**[0052]** The packaging and application device 1 shown in figure 1 comprises a container 2 and an applicator 3 for applying the product contained in the container 2.

**[0053]** This product is a cosmetic, makeup or care, product, and the applicator 3 comprises a stem 31 that bears at one end an applicator member 32 for applying the product and is connected at the other end to a gripping member 33, which is likewise designed to form a closure member of the container 2.

**[0054]** In the example in question, the product contained in the container is mascara and the applicator member 32 is a mascara brush or comb, produced for example by injection-molding thermoplastic material.

**[0055]** The container 2 comprises a body 20 provided with a threaded neck 21, onto which the gripping member 33 can be screwed.

**[0056]** In order to wipe off the stem 31 and the applicator member 32 during the withdrawal of the applicator 3 from the container 2, a wiping device 4 is present in the neck 21 of the container 2. This wiping device 4, shown on its own in figure 2, has an upper part (or fastening part 5) for fastening in the neck 21, and a lower part 6 (or wiping part) provided with a wiping lip 61 which defines an opening 62 through which the applicator member 32 and the stem 31 can pass when the applicator 3 is fastened to the container 2.

**[0057]** The upper part 5 has, at its upper end, a flange 51 which is directed radially toward the outside and presses against the upper portion of the neck 21 of the container. The rim formed by the flange can also contribute, if need be, toward the leaktightness of the closure of the container by being clamped by the gripping member 33 once it has been screwed onto the container.

**[0058]** The flange 51 can have an introduction chamfer 52 as illustrated.

**[0059]** The body 53 of the upper part 5 is divided toward the bottom into an inner skirt 54 and an outer skirt 55 which define an annular groove 56 between one another. The outer skirt 55 has, on its inner surface 57, an annular bulge 58 which defines an annular groove 71 with its lower end 59. Said annular groove is delimited upwardly by a shoulder 72 and downwardly by a slope 73 which converges toward the inside as it nears the lower end 59 of the outer skirt. The shoulder 72 is oriented substantially perpendicularly to the longitudinal axis X of the wiping device 4.

**[0060]** Above the bulge 58, the outer skirt 55 has a surface which is inclined toward the inside and toward

the bottom of the groove 56, as is visible notably in figure 5.

**[0061]** The region of largest outside diameter of the outer skirt 55 is situated along the axis X, substantially at the level of the bulge 58, in the example in question.

**[0062]** The inner skirt 54 has a radially inner surface which is offset toward the axis X compared with the inner surface 75 of the body 53 of the fastening part, with a slope 76 connecting the surfaces 77 and 75. In the example in question, the surface 77 is substantially parallel to the axis X.

**[0063]** The radially outer surface 81 of the inner skirt 54 has a portion which is substantially parallel to the axis X and is terminated toward the bottom by a chamfer 83 that defines a ridge 85 with the substantially cylindrical portion 84.

**[0064]** The outer skirt 55 extends axially further than the inner skirt 54.

**[0065]** The lower part 6 of the wiping device 4 has a body 63 which bears the wiping lip 61 and is extended at its upper end by a mounting skirt 65 which is designed to be fitted into the groove 56 in the upper part 5 when the two pieces are assembled, as illustrated in figure 2.

**[0066]** The mounting skirt 65 forms with the body 63, at its base, a shoulder 69 against which the lower end of the inner skirt 54 presses, as can be seen notably in figure 3.

**[0067]** The fastening skirt 65 has an angled shape, with a lower portion 91 which extends radially toward the outside in the direction of the upper part, and an upper portion 92 which forms, with the lower portion, an angled region 93, the upper portion 92 extending substantially parallel to the axis X, with an inner surface 94 substantially parallel to the axis X and an outer surface 95 that generally converges toward the axis X and toward the upper end of the fastening skirt 65. The angled region 93 defines a region of largest outside diameter of the fastening skirt 65.

**[0068]** The wall of the body 63 may, as illustrated, be thicker in a region 100 situated under the fastening skirt and the thickness of the body may decrease toward the lower end of the lower part.

**[0069]** In the example illustrated in figures 2 to 14, the wiping lip 61 has a wavy shape, extending generally obliquely toward the inside and toward the lower end of the lower part 6, although the invention is not limited to a particular shape of the wiping lip.

**[0070]** The lower part may be produced with at least one notch that is useful for positioning the lower part on the assembly line. In the example in question, the body 63 is thus produced with two diametrically opposite notches 110, of rectangular contour, that extend over a portion of the body from its lower end, which has a substantially constant thickness, the bottom of the notch being situated beneath the level of the lower end of the wiping lip.

**[0071]** The thickened part of the body 63 defines, with the fastening skirt 65, an annular groove 120 in the outer

surface of the body.

**[0072]** The upper part 5 is made of a more rigid material than the lower part 6, the two pieces preferably each being made by injection-molding thermoplastic material.

**[0073]** The upper part 5 and lower part 6 are designed to be able to be preassembled before the assembly is fastened in the neck of the container.

**[0074]** More particularly, as illustrated in figures 4 and 5, the inside diameter of the lower end part of the outer skirt 55 has a diameter which is preferably slightly less than the largest outside diameter of the fastening skirt 65, such that the positioning of the upper part 5 on the lower part 6 is accompanied by an elastic deformation of the outer skirt 55 to allow the latter to pass over the angled region 93 of the fastening skirt 65 and thereby to keep the two pieces together. The preassembly consists in inserting the fastening skirt 65 axially into the annular groove 56 until the inner skirt 54 butts against the shoulder 69. At the end of this insertion, the upper part of the fastening skirt 65 presses, as can be seen notably in figure 3, against the oblique inner surface of the outer skirt 55, thereby ensuring that the lower part 6 is held on the upper part 5 by jamming and making it difficult to disconnect the two pieces, even if a push is exerted on the lower part 6 on account for example of the applicator being reintroduced into the container off-center.

**[0075]** Figure 14 shows notably that, when the fastening skirt 65 is in position in the groove 56, there is an axial clearance  $k$ , this clearance making it possible to absorb manufacturing tolerances and to ensure that, during preassembly, the inner skirt 54 presses properly against the shoulder 69 at the base of the fastening skirt 65.

**[0076]** Of course, the invention is not limited to a particular embodiment of the mounting skirt 65.

**[0077]** By way of example, figures 15 and 16 show a variant of the lower part 6 in which the mounting skirt 65 is in the form of a cone that downwardly extends the body 63 of the lower part 6, it also being possible for further embodiments to be implemented.

**[0078]** The invention is also not limited to a wiping device in which the upper part for fastening in the neck is rotationally symmetrical. In particular, the cross section of the body may be noncircular, for example elongate, notably oval or elliptical.

**[0079]** Further shapes can be given to the upper and lower parts, notably in the portions that serve for fastening one in the other, without departing from the scope of the present invention.

**[0080]** The relief 58 may be angularly discontinuous, so as to be in the form of teeth for example.

## Claims

1. A device (1) for packaging and applying a product, comprising:

- a container (2) containing the product and having a neck (21),
- an applicator (3) having an applicator member (32) carried by a stem (31), and
- a wiping device (4) having:

- a wiping part (6) for wiping off the applicator member (32) and the stem (31) as they leave the container (2), and
- a fastening part (5) for fastening the wiping device (4) in the neck (21) of the container (2),

one of the fastening part (5) and the wiping part having an outer skirt (55) and an inner skirt (54) that define an annular groove (56) between one another, the other of the fastening part and the wiping part (6) having a mounting skirt (65) fitted in said groove (56), the fastening part (5) and wiping part (6) being arranged so as to allow preassembly of the wiping device (4) before it is mounted in the neck (21), wherein the outer skirt (55) is being deformed radially inward by the neck (21) while the wiping device (4) is being mounted in the neck (21), and being pressed against the mounting skirt (65) at least when the wiping device (4) is in a configuration mounted in the neck (21), and wherein the outer skirt (55) has a relief (58) that engages with the mounting skirt (65) in this configuration in order to prevent any detachment of the fastening part (5) and the wiping part (6).

2. The device (1) as claimed in the preceding claim, wherein said relief (58) is formed by a protruding bulge on the inner surface of the outer skirt (55).
3. The device (1) as claimed in the preceding claim, wherein the outer skirt (55) has, between its free edge (59) and said bulge, a groove (71) that is open toward the mounting skirt (65).
4. The device (1) as claimed in any one of the preceding claims, wherein the mounting skirt (65) has an angled region (93) with an outside diameter which passes through a maximum at a distance from its free edge.
5. The device (1) as claimed in the preceding claim, wherein said angled region (93) is positioned axially between the bottom of the annular groove (56) formed between the outer skirt (55) and inner skirt (54) and said relief (58).
6. The device (1) as claimed in claim 4 or 5, wherein the mounting skirt (65) presses against the inner surface (57) of the outer skirt (55) above the angled region (93).

7. The device (1) as claimed in any one of the preceding claims, wherein the free edge of the mounting skirt (65) is at a distance from the bottom of the annular groove (56) formed between the inner skirt (54) and the outer skirt (55).
8. The device (1) as claimed in any one of the preceding claims, wherein the inner skirt (54) has a chamfer (83) that presses against the mounting skirt (65).
9. The device (1) as claimed in the preceding claim, wherein said chamfer (83) presses against a part of the mounting skirt (65) that is situated between the angled region (93) and a body (63) of the wiping part (6).
10. The device (1) as claimed in either of the two preceding claims, wherein the inner skirt (54) presses axially against a shoulder (69) at the base of the mounting skirt (65).
11. The device (1) as claimed in any one of the preceding claims, wherein the outer skirt (55) is longer than the inner skirt (54).
12. The device (1) as claimed in any one of the preceding claims, wherein the fastening part (5) has a body of substantially cylindrical shape that is provided at its upper end with a flange (51).
13. The device (1) as claimed in any one of the preceding claims, wherein the fastening part (5) is made of a thermoplastic material, in particular PE or TPE.
14. The device (1) as claimed in any one of the preceding claims, wherein the wiping part (6) is made of an elastomer.
15. The device (1) as claimed in any one of the preceding claims, wherein the body (63) of the wiping part (6) has a lower portion having at least one notch (110) in its circumference.
16. The device (1) as claimed in any one of the preceding claims, wherein the body (63) of the wiping part (6) defines, with the mounting skirt (65), an annular groove (120) in the outer surface of the body.
17. A wiping part (6) for a wiping device (1) as claimed in any one of the preceding claims, having a wiping lip (61) for wiping off the stem (31) and the applicator member (32) of an applicator passed through the wiping device (1), the wiping lip (61) being connected to a body (63) surmounted by a mounting skirt (65) on a fastening part that serves for holding in the neck of the container, said mounting skirt having an angled region (93) that defines a region of largest outside diameter of the skirt.

18. A method for mounting a wiping device (1) as defined in any one of claims 1 to 16, comprising:

- the preassembly of the wiping part (6) and the fastening part (5),
- the introduction of the preassembled assembly into the neck (21) of the container (2) so as to deform the outer skirt (55) and to prevent any detachment of the fastening part (5) and of the wiping part (6) as a result of the relief (58) on the outer skirt (55) pressing against the mounting skirt (65).

#### 15 Patentansprüche

1. Vorrichtung zum Verpacken und Anwenden eines Produkts, umfassend:

- einen Behälter (2), der das Produkt enthält und ein Halsstück (21) aufweist,
- einen Applikator (3), der ein Applikator-Glied (32) aufweist, das durch einen Stiel (31) getragen wird, und
- eine Wischvorrichtung (4), die Folgendes aufweist:
  - ein Wischteil (6) zum Abstreifen des Applikator-Glieds (32) und des Stiels (31), wenn sie den Behälter (2) verlassen, und
  - ein Befestigungsteil (5) zum Befestigen der Wischvorrichtung (4) in dem Halsstück (21) des Behälters (2),

wobei eines von dem Befestigungsteil (5) und dem Wischteil eine äußere Schürze (55) und eine innere Schürze (54) aufweist, die zwischen sich eine ringförmige Nut (56) definieren, wobei das andere des Befestigungsteils und des Wischteils (6) eine Montageschürze (65) aufweist, die in die Nut (56) eingepasst ist, wobei das Befestigungsteil (5) und Wischteil (6) angeordnet sind, um eine Vorabzusammensetzung der Wischvorrichtung (4) zu erlauben, bevor sie in dem Halsstück (21) montiert wird, wobei die äußere Schürze (55) durch das Halsstück (21) radial nach innen verformt wird, während der Wischvorrichtung (4) in dem Halsstück (21) montiert wird, und mindestens dann an die Montageschürze (65) gedrückt wird, wenn sich die Wischvorrichtung (4) in einer in dem Halsstück (21) montierten Konfiguration befindet, und wobei die äußere Schürze (55) ein Relief (58) aufweist, das in dieser Konfiguration in die Montageschürze (65) eingreift, um eine Loslösung des Befestigungsteils (5) und des Wischteils (6) zu verhindern.

2. Vorrichtung (1) nach dem vorstehenden Anspruch, wobei das Relief (58) durch eine hervorstehende

- Ausbuchtung an der Innenoberfläche der äußeren Schürze (55) gebildet wird.
3. Vorrichtung (1) nach dem vorstehenden Anspruch, wobei die äußere Schürze (55) zwischen ihrer freien Kante (59) und der Ausbuchtung eine Nut (71) aufweist, die zur Montageschürze (65) hin offen ist. 5
4. Vorrichtung (1) nach einem der vorstehenden Ansprüche, wobei die Montageschürze (65) eine winkelige Region (93) mit einem Außendurchmesser aufweist, die ein Maximum in einem Abstand von ihrer freien Kante durchläuft. 10
5. Vorrichtung (1) nach dem vorstehenden Anspruch, wobei die winkelige Region (93) axial zwischen dem Boden der ringförmigen Nut (56), die zwischen der äußeren Schürze (55) und der inneren Schürze (54) gebildet ist, und dem Relief (58) positioniert ist. 15
6. Vorrichtung (1) nach Anspruch 4 oder 5, wobei die Montageschürze (65) oberhalb der winkelligen Region (93) gegen die Innenoberfläche (57) der äußeren Schürze (55) drückt. 20
7. Vorrichtung (1) nach einem der vorstehenden Ansprüche, wobei sich die freie Kante der Montageschürze (65) in einem Abstand von dem Boden der ringförmigen Nut (56), die zwischen der inneren Schürze (54) und der äußeren Schürze (55) gebildet ist, befindet. 30
8. Vorrichtung (1) nach einem der vorstehenden Ansprüche, wobei die innere Schürze (54) eine Fase (83) aufweist, die gegen die Montageschürze (65) drückt. 35
9. Vorrichtung (1) nach einem vorstehenden Anspruch, wobei die Fase (83) gegen einen Teil der Montageschürze (65) drückt, die zwischen der winkelligen Region (93) und einem Körper (63) des Wischteils (6) gelegen ist. 40
10. Vorrichtung (1) nach einem der beiden vorstehenden Ansprüche, wobei die innere Schürze (54) an der Basis der Montageschürze (65) axial gegen eine Schulter (69) drückt. 45
11. Vorrichtung (1) nach einem der vorstehenden Ansprüche, wobei die äußere Schürze (55) länger als die innere Schürze (54) ist. 50
12. Vorrichtung (1) nach einem der vorstehenden Ansprüche, wobei das Befestigungsteil (5) einen Körper von im Wesentlichen zylindrischer Gestalt aufweist, der an seinem oberen Ende mit einem Flansch (51) bereitgestellt ist. 55
13. Vorrichtung (1) nach einem der vorstehenden Ansprüche, wobei das Befestigungsteil (5) aus einem thermoplastischen Material, insbesondere PE oder TPE gefertigt ist.
14. Vorrichtung (1) nach einem der vorstehenden Ansprüche, wobei das Wischteil (6) aus einem Elastomer gefertigt ist.
15. Vorrichtung (1) nach einem der vorstehenden Ansprüche, wobei der Körper (63) des Wischteils (6) einen unteren Abschnitt aufweist, der in seinem Umfang mindestens eine Kerbe (110) aufweist.
16. Vorrichtung (1) nach einem der vorstehenden Ansprüche, wobei der Körper (63) des Wischteils (6) mit der Montageschürze (65) eine ringförmige Nut (120) an der Außenoberfläche des Körpers definiert.
17. Wischteil (6) für eine Wischvorrichtung (1) nach einem der vorstehenden Ansprüche, das eine Wischlippe (61) zum Abstreifen des Stiels (31) und des Applikator-Glieds (32) eines Applikators aufweist, der durch die Wischvorrichtung (1) hindurchführt, wobei die Wischlippe (61) mit einem Körper (63) verbunden ist, der von einer Montageschürze (65) auf einem Befestigungsteil überragt wird, das dazu dient, die Montageschürze in dem Halsstück des Behälters zu halten, wobei die Montageschürze eine winkelige Region (93) aufweist, die eine Region des größten Außendurchmessers der Schürze definiert.
18. Verfahren zum Montieren einer Wischvorrichtung (1) nach einem der Ansprüche 1 bis 16, Folgendes umfassend:
- die Vorabzusammensetzung des Wischteils (6) und des Befestigungsteils (5),
  - das Einführen der vorab zusammengesetzten Zusammensetzung in das Halsstück (21) des Behälters (2), um die äußere Schürze (55) zu verformen, und um eine Loslösung des Befestigungsteils (5) und des Wischteils (6) als Ergebnis davon zu verhindern, dass das Relief (58) an der äußeren Schürze (55) gegen die Montageschürze (65) drückt.

### Revendications

1. Dispositif (1) d'emballage et d'application d'un produit, comprenant :
- un récipient (2) contenant le produit et ayant un goulot (21),
  - un applicateur (3) ayant un organe applicateur (32) porté par une tige (31), et
  - un dispositif d'essuyage (4) ayant :

- une partie d'essuyage (6) pour essuyer l'organe applicateur (32) et la tige (31) lorsqu'ils sortent du récipient (2), et
- une partie de fixation (5) pour fixer le dispositif d'essuyage (4) dans le goulot (21) du récipient (2),

l'une parmi la partie de fixation (5) et la partie d'essuyage ayant une jupe extérieure (55) et une jupe intérieure (54) qui définissent une rainure annulaire (56) entre elles,

l'autre parmi la partie de fixation et la partie d'essuyage (6) ayant une jupe de montage (65) ajustée dans ladite rainure (56),

la partie de fixation (5) et la partie d'essuyage (6) étant agencées de manière à permettre l'assemblage préalable du dispositif d'essuyage (4) avant son montage dans le goulot (21),

dans lequel la jupe extérieure (55) est déformée radialement vers l'intérieur par le goulot (21) pendant que le dispositif d'essuyage (4) est monté dans le goulot (21), et est pressée contre la jupe de montage (65) au moins lorsque le dispositif d'essuyage (4) est dans une configuration montée dans le goulot (21), et

dans lequel la jupe extérieure (55) a un relief (58) qui s'engage avec la jupe de montage (65) dans cette configuration pour empêcher tout détachement de la partie de fixation (5) et de la partie d'essuyage (6).

2. Dispositif (1) selon la revendication précédente, dans lequel ledit relief (58) est formé par un renflement saillant sur la surface intérieure de la jupe extérieure (55) .
3. Dispositif (1) selon la revendication précédente, dans lequel la jupe extérieure (55) a, entre son bord libre (59) et ledit renflement, une rainure (71) qui est ouverte vers la jupe de montage (65).
4. Dispositif (1) selon l'une quelconque des revendications précédentes, dans lequel la jupe de montage (65) a une région inclinée (93) avec un diamètre extérieur qui passe à travers un maximum à une distance de son bord libre.
5. Dispositif (1) selon la revendication précédente, dans lequel ladite région inclinée (93) est positionnée axialement entre le fond de la rainure annulaire (56) formée entre la jupe extérieure (55) et la jupe intérieure (54) et ledit relief (58).
6. Dispositif (1) selon la revendication 4 ou 5, dans lequel la jupe de montage (65) appuie contre la surface intérieure (57) de la jupe extérieure (55) au-dessus de la région inclinée (93).
7. Dispositif (1) selon l'une quelconque des revendica-

tions précédentes, dans lequel le bord libre de la jupe de montage (65) est à une distance du fond de la rainure annulaire (56) formée entre la jupe intérieure (54) et la jupe extérieure (55).

8. Dispositif (1) selon l'une quelconque des revendications précédentes, dans lequel la jupe intérieure (54) a un biseau (83) qui appuie contre la jupe de montage (65).
9. Dispositif (1) selon la revendication précédente, dans lequel ledit biseau (83) appuie contre une partie de la jupe de montage (65) qui est située entre la région inclinée (93) et un corps (63) de la partie d'essuyage (6) .
10. Dispositif (1) selon l'une des deux revendications précédentes, dans lequel la jupe intérieure (54) appuie axialement contre un épaulement (69) à la base de la jupe de montage (65).
11. Dispositif (1) selon l'une quelconque des revendications précédentes, dans lequel la jupe extérieure (55) est plus longue que la jupe intérieure (54) .
12. Dispositif (1) selon l'une quelconque des revendications précédentes, dans lequel la partie de fixation (5) a un corps de forme sensiblement cylindrique qui est pourvu, à son extrémité supérieure, d'une bride (51) .
13. Dispositif (1) selon l'une quelconque des revendications précédentes, dans lequel la partie de fixation (5) est constituée d'un matériau thermoplastique, en particulier de PE ou TPE.
14. Dispositif (1) selon l'une quelconque des revendications précédentes, dans lequel la partie d'essuyage (6) est constituée d'un élastomère.
15. Dispositif (1) selon l'une quelconque des revendications précédentes, dans lequel le corps (63) de la partie d'essuyage (6) a une portion inférieure ayant au moins une encoche (110) dans sa circonférence.
16. Dispositif (1) selon l'une quelconque des revendications précédentes, dans lequel le corps (63) de la partie d'essuyage (6) définit, avec la jupe de montage (65), une rainure annulaire (120) dans la surface extérieure du corps.
17. Partie d'essuyage (6) pour un dispositif d'essuyage (1) selon l'une quelconque des revendications précédentes, ayant une lèvre d'essuyage (61) pour essuyer la tige (31) et l'organe applicateur (32) d'un applicateur passé à travers le dispositif d'essuyage (1), la lèvre d'essuyage (61) étant reliée à un corps (63) surmonté d'une jupe de montage (65) sur une

partie de fixation qui sert à maintenir dans le goulot du récipient, ladite jupe de montage ayant une région inclinée (93) qui définit une région de diamètre extérieur le plus grand de la jupe.

5

18. Procédé de montage d'un dispositif d'essuyage (1) selon l'une quelconque des revendications 1 à 16, comprenant :

- l'assemblage préalable de la partie d'essuyage (6) et la partie de fixation (5), 10
- l'introduction de l'ensemble préalablement assemblé dans le goulot (21) du récipient (2) de manière à déformer la jupe extérieure (55) et à empêcher tout détachement de la partie de fixation (5) et de la partie d'essuyage (6) en raison de la pression du relief (58) de la jupe extérieure (55) contre la jupe de montage (65). 15

20

25

30

35

40

45

50

55

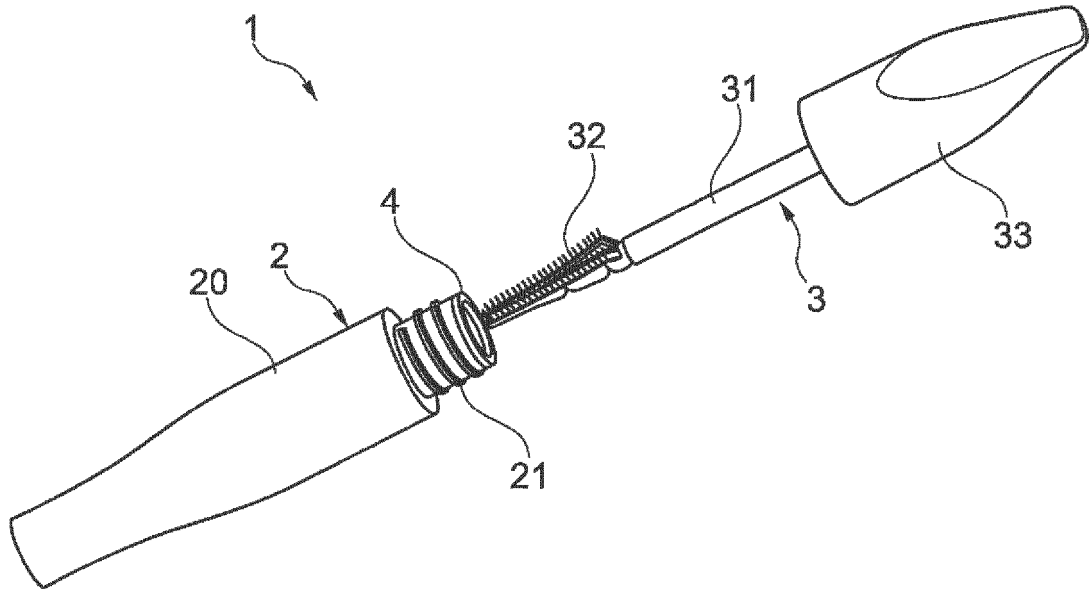

Fig. 1

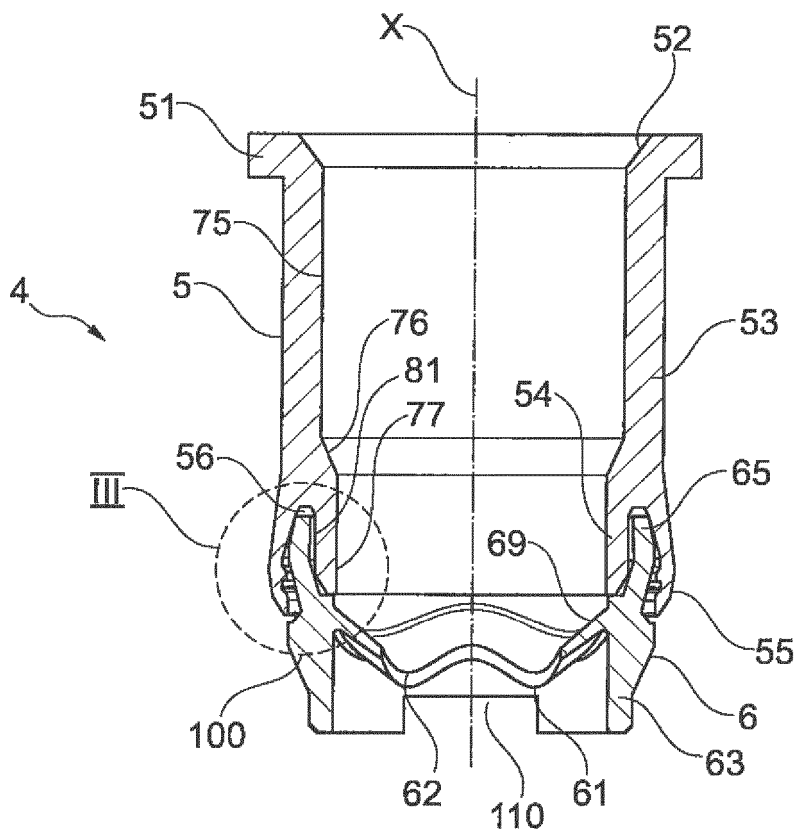

Fig. 2

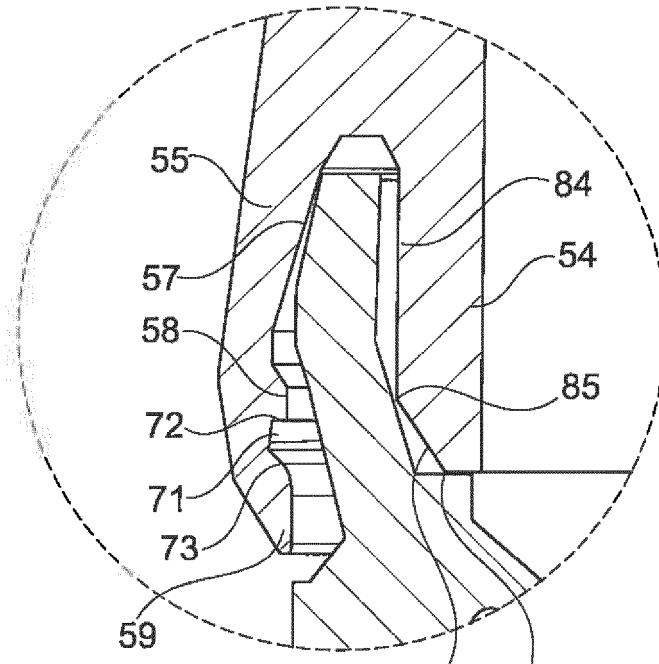

Fig. 3

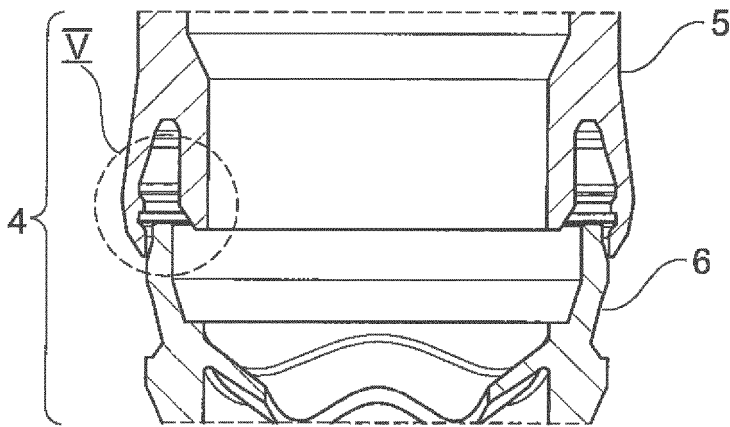

Fig. 4

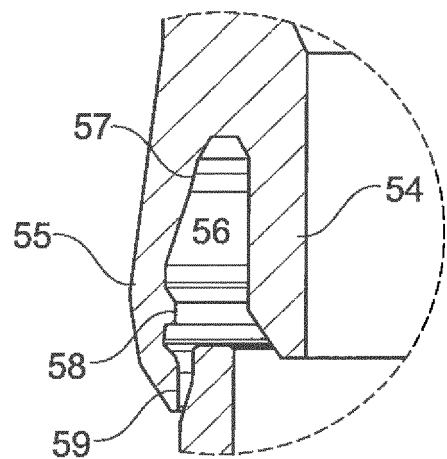

Fig. 5

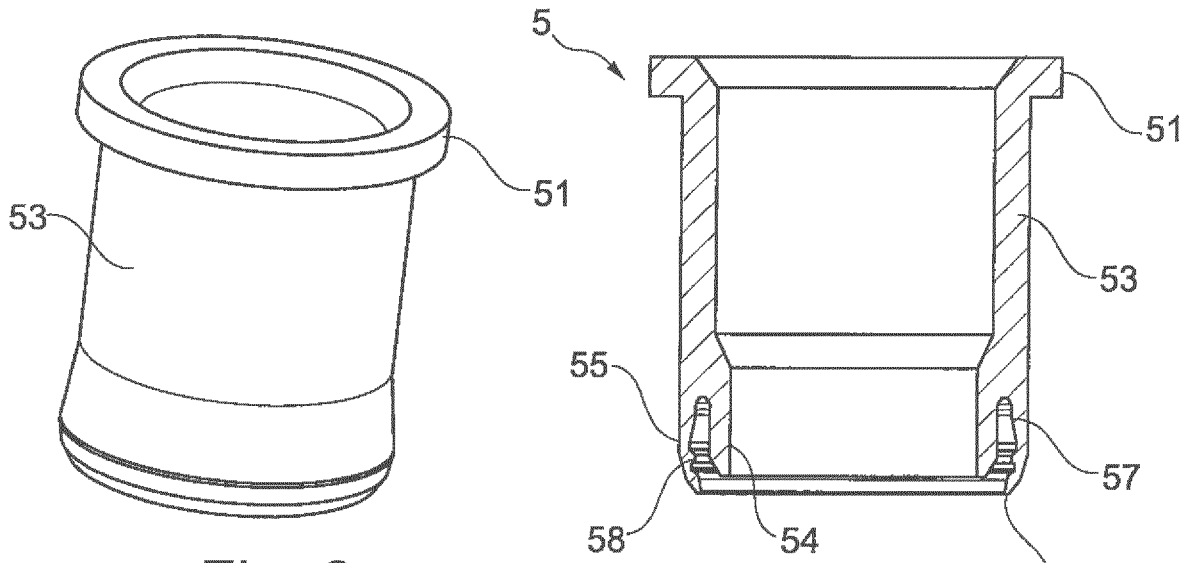

Fig. 6

Fig. 7

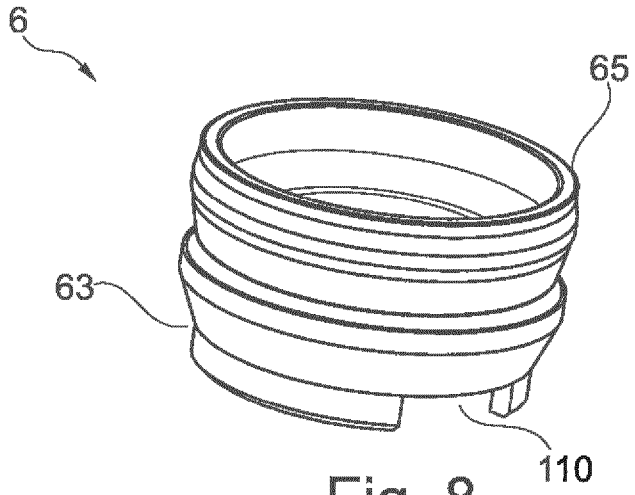

Fig. 8

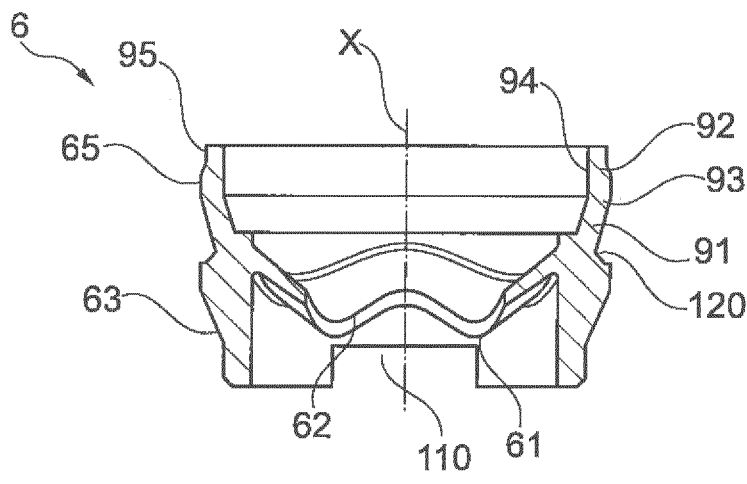
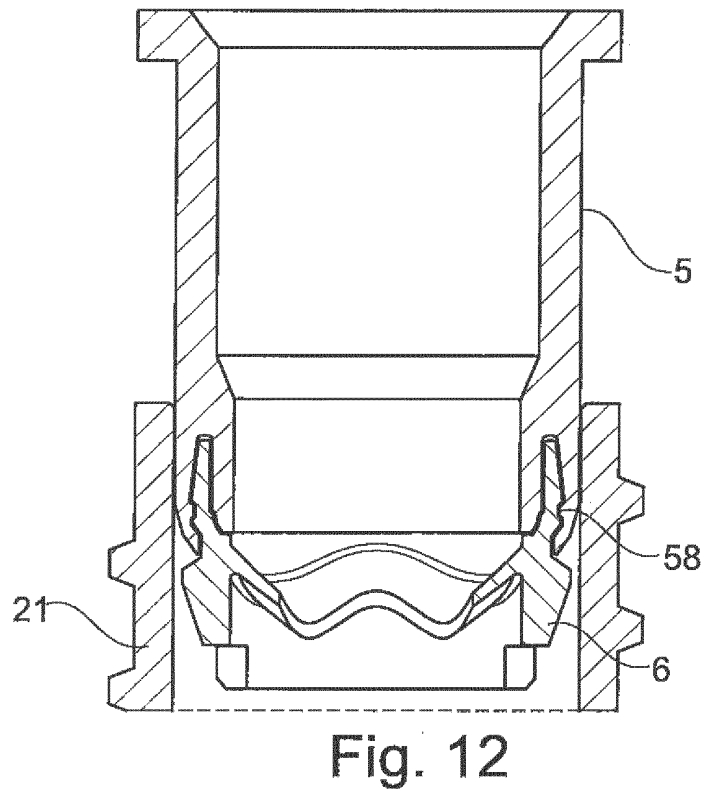
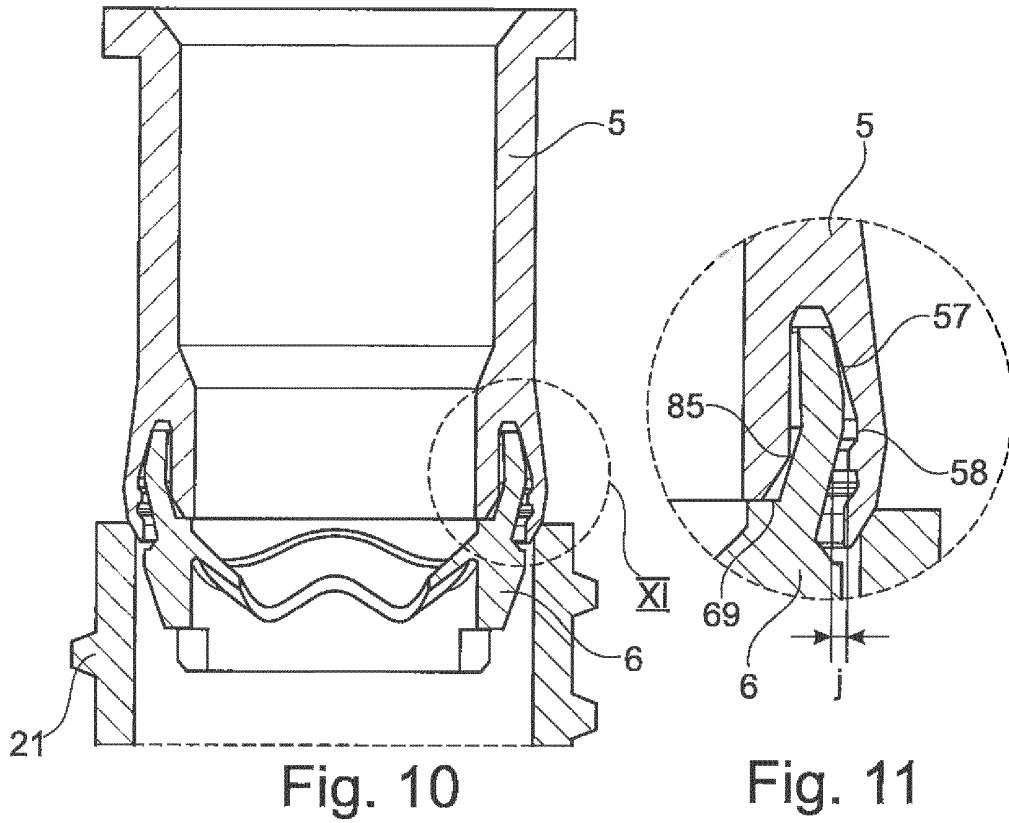

Fig. 9



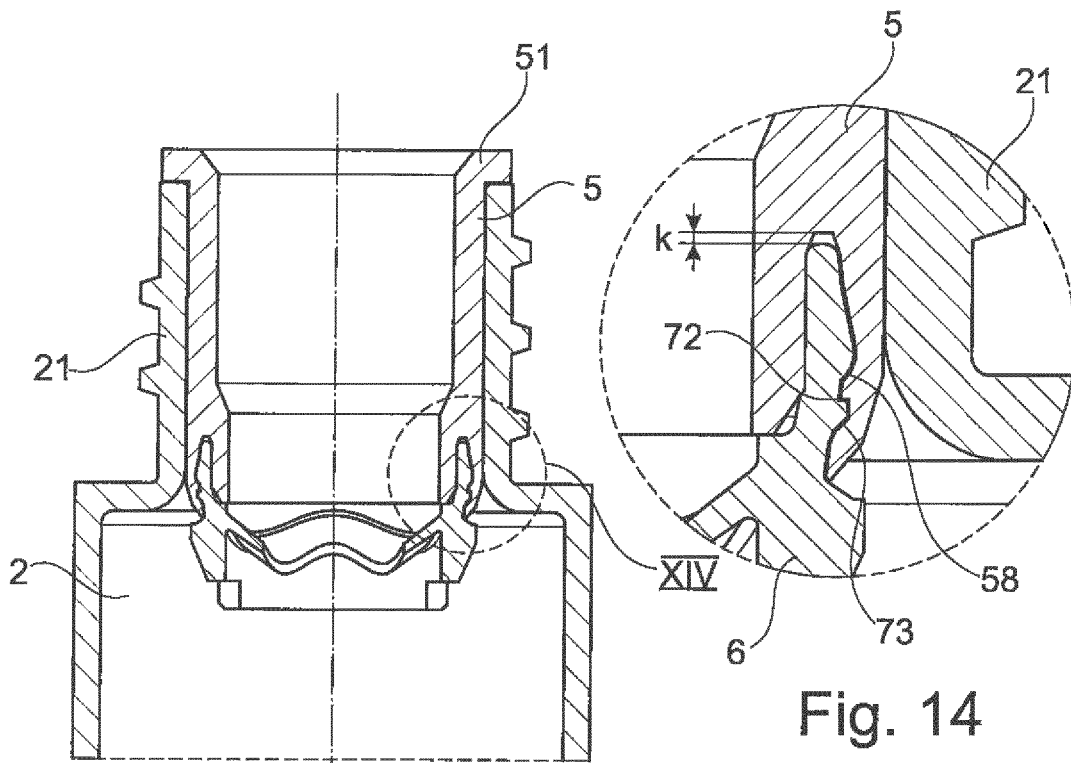

Fig. 13

Fig. 14

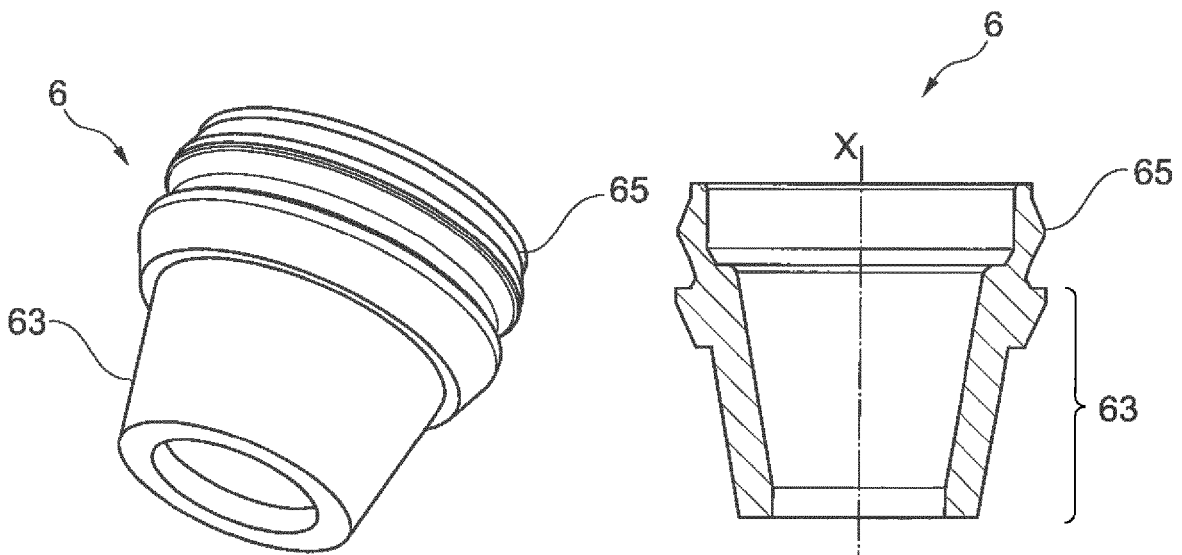

Fig. 15

Fig. 16

**REFERENCES CITED IN THE DESCRIPTION**

*This list of references cited by the applicant is for the reader's convenience only. It does not form part of the European patent document. Even though great care has been taken in compiling the references, errors or omissions cannot be excluded and the EPO disclaims all liability in this regard.*

**Patent documents cited in the description**

- FR 3005835 [0008]
- FR 2679113 [0011]
- FR 2865911 [0015]
- FR 2855380 [0017]
- FR 3028731 [0018]
- EP 1561394 A [0019]
- EP 0627182 A [0020]