

(No Model.)

H. S. HALE.  
CAR SEAT.

No. 432,702.

Patented July 22, 1890.

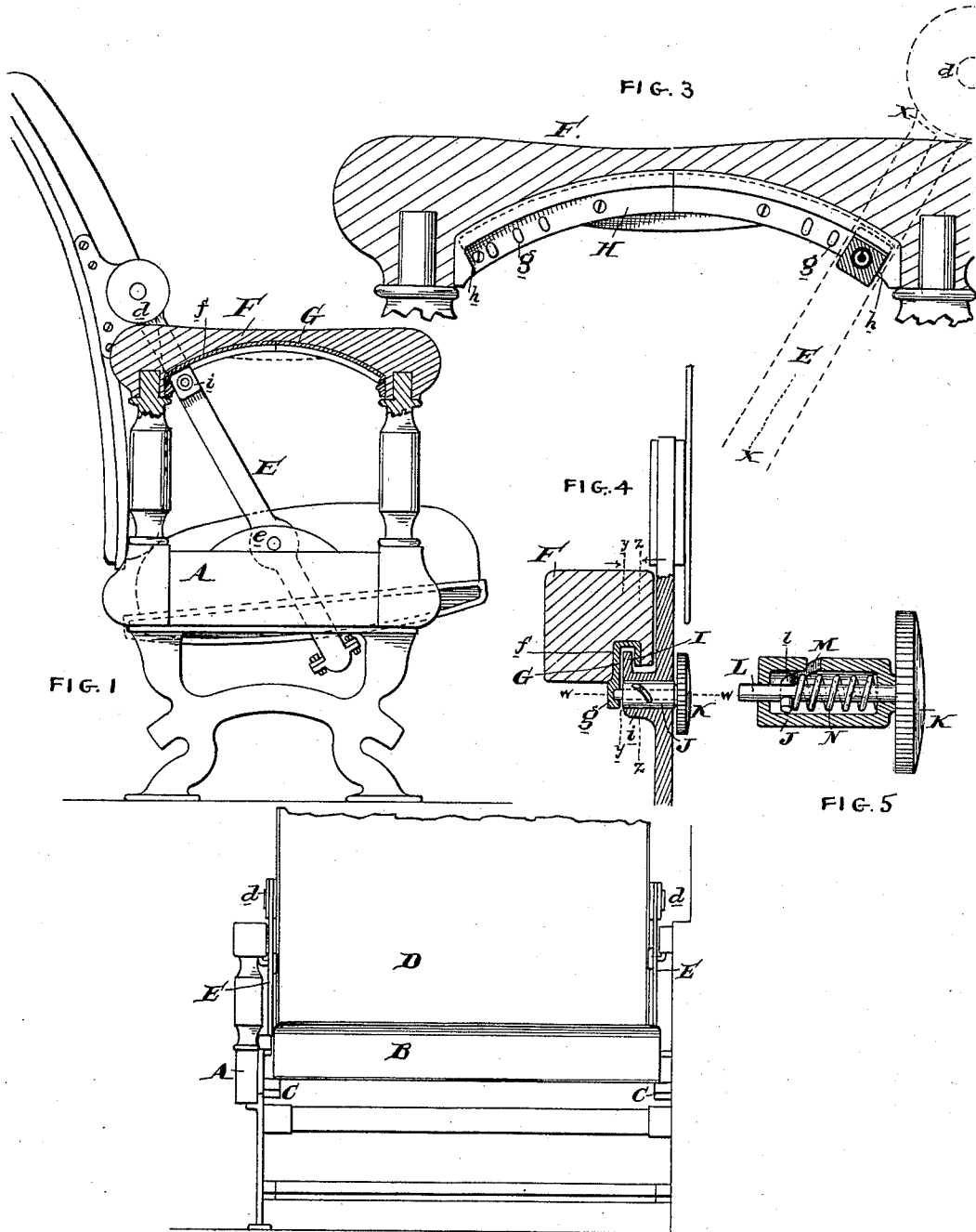

Witnesses:

*Harry Dury*  
*E. W. Beckman*

FIG. 2

Inventor:

Henry S. Hale  
by his Atty.

*[Signature]*

# UNITED STATES PATENT OFFICE.

HENRY S. HALE, OF PHILADELPHIA, PENNSYLVANIA.

## CAR-SEAT.

SPECIFICATION forming part of Letters Patent No. 432,702, dated July 22, 1890.

Application filed September 25, 1888. Serial No. 286,395. (No model.)

*To all whom it may concern:*

Be it known that I, HENRY S. HALE, of the city and county of Philadelphia and State of Pennsylvania, have invented an Improvement in Car-Seats, of which the following is a specification.

My invention has reference to car-seats; and it consists of certain improvements, all of which are fully set forth in the following specification, and shown in the accompanying drawings, which form part thereof.

My invention has for its object the general improvements in the connection of the seat-back to the main frame whereby the hinge-arms are guided at all times in metal guides and cannot come into contact with the wood-work of the arm-rest and are provided with suitable locks adapted to secure the seat-back in various adjustments by locking the hinge-arm to the guide in different positions of its travel.

My invention is also especially directed to the adjustable locking device which is carried by the hinge-arm.

In the drawings, Figure 1 is an end elevation of a car-seat embodying my invention with a portion of the arm-rest cut away on line *yy* of Fig. 4. Fig. 2 is a front elevation of the car-seat. Fig. 3 is a sectional elevation of the arm-rest and portion of the hinge-arm on line *zz* of Fig. 4. Fig. 4 is a cross-section of Fig. 3 on line *xx*, and Fig. 5 is a sectional elevation of the spring-lock removed from the hinge-arm.

A is the main frame.

B is the seat-cushion, which is supported on the frames C or in any other well-known manner, and may be stationary or adapted to shift and tilt.

D is the seat-back, and is pivoted at *d* to the upper ends of the hinge-arms E, the lower ends of which are pivoted at *e* to the main frame, directly or indirectly, at some distance below the center of the arm-rests.

This seat may be arranged against the car-wall, as shown in Fig. 2, or it may have two well-defined arm-rests F carried by the main frame A. The under part of the arm-rest is grooved, as at *f*, curved about *e* as a center, and receives the metallic curved and grooved guide G, one of whose faces is projected down

below the other, as at H, the extended face being farthest away from the seat. This guide G has stops *h* at each end, and also has its face H provided with a series of holes or recesses *g* at or near each end. The hinge-arms E have laterally-projecting hubs *i* terminating in upwardly-extending lugs I, which loosely fit up into the channels or grooves of the guides G. These lugs prevent lateral motion to the hinge-arms, keeping them away from the wood-work and also guiding them parallel to the guide G. These lugs also strike the stops *h* in the ends of the guides and limit the extreme movements of the hinge-arms in reversing the seat-back. The lug *i* on one or both hinge-arms is bored out and a lock J fitted in, as shown in Fig. 4. This lock consists of its case, in which is located the bolt L, having the head or handle K. Surrounding this bolt is a spring N for pushing the bolt out of its case, the said spring acting on a cross-pin *l* on the bolt, and which pin projects through a curved or oblique slot M in the case. (See Figs. 4 and 5.) The lock is driven into the hole in the hinge-arm, and the head K fits up close to the inner or seat side of the hinge-arm, presenting no obstruction upon which to catch the garments. Besides this, head K is on the hinge-arm, and hence is always next to the seat-back or away from the position at the forward or front part of the seat. The bolt L of the lock is in such position that it may engage with the stops, recesses, or holes *g* in the face H of the guide G. The stops, holes, or recesses *g* are preferably made oblong, radiating from *e* as a center, so as to obviate too nice an adjustment of the parts and also to allow for the usual shrinkage in wood-work.

It will now be seen that by turning the handle or head K of the bolt that the latter will be drawn by the pin and cam compressing the spring, and after the back and hinge arms have been adjusted the bolt is liberated and allowed to catch into the desired stop, recess, or hole. In this manner the seat-back may be adjusted to suit the desire of the occupant of the seat. The solid part of the face H between the two series of stops, recesses, or holes acts as a guide and holds back the bolt L until the seat-back is fully reversed when shift-

ing the seat to suit a changed direction of travel or for other reasons. The lock is carried by the hinge-arms, and hence is shifted from one end of the guide to the other, necessitating only one-half the number of locks or catches formerly found necessary in the simplest form of seat.

The lock may be employed in other specific forms of seat-arms; but my invention comprehends a locking device carried wholly by the hinge-arm.

It is evident that while my invention is applicable to ordinary forms of wide car-seats, it is equally applicable to the double car-seats now coming into use, and which are simply two narrow seats arranged side by side.

I do not limit myself to the mere details here set out, as they may be modified in various ways without departing from the spirit of my invention.

Having now described my invention, what I claim as new, and desire to secure by Letters Patent, is—

1. The combination of the main frame, a curved guide on the arm-rest having a continuous groove, a seat-back, a hinge-arm therefor connecting with the main frame and having a lug projecting into the groove of the guide, and a locking-bolt carried wholly by the hinge-arm for securing it in different positions on the guide.

2. The combination of the main frame, a curved and grooved guide on the arm-rest having a downwardly-extending face furnished with a series of recesses or holes, a seat-back, a hinge-arm therefor connecting with the main frame and having a lug projecting into the groove of the guide, a lock carried wholly by the hinge-arm for securing it in different positions on the guide, and having its bolt in line with the downwardly-extending face of the guide and its recesses or holes.

3. The combination of the main frame and stationary arm-rest with a stationary curved plate secured to the arm-rest and having a series of holes or recesses, said plate being located at considerable distance above the seat and curved from a center located below the plate, an adjustable seat-back independent of the seat and arm-rest, a hinge-arm independent of the curved plate connecting the middle of the seat-back and main frame at the fixed center for the curved plate, and a locking-bolt carried by the hinge-arm to fit into the recesses or holes to hold the back in different adjustments.

4. The combination of the main frame and fixed arm-rest arranged above the seat with a stationary curved plate secured to the arm-rest and having a series of holes or recesses at each end and curved from a fixed center below the plate, an adjustable and reversible seat-back independent of the seat and arm-rest, a hinge-arm independent of the curved plate connecting the middle of the seat-back and main frame below the curved plate, and

a locking-bolt carried by the hinge-arm to fit into the recesses or holes of the curved plate to hold the back in different adjustments in either of its reversed positions.

5. The combination of the main frame having a series of bolt-receiving recesses or apertures and cushion-seat, a reversible seat-back independent of the seat-cushion, a hinge-arm pivoted at one end to the middle of the seat-back and at the other end to the main frame below the arm-rest, and a locking-bolt carried wholly by the hinge-arm and movable with it.

6. The combination of the main frame having a stationary arm and a series of bolt-receiving recesses or apertures and a cushion-seat, a reversible seat-back independent of the seat-cushion, a hinge-arm pivoted at one end to the middle of the seat-back and at the other end to the main frame below the arm-rest, and a spring locking-bolt carried wholly by the hinge-arm and movable with it and terminating in a handle or head arranged close to the inner surface of the hinge-arm and locking into the stationary arm at each end of its movement.

7. In a car-seat, the combination of an adjustable seat-back, an arm-rest provided with catches or holes, a pivoted hinge-arm connecting with said back, a locking-bolt carried in said hinge-arm adapted to engage in said catches or holes in the arm-rest to lock said hinge-arm in position, a cam-surface in which a projecting portion of the bolt works to move it longitudinally when turned, a spring to resist the longitudinal movement of the bolt, and a handle or head for said bolt to turn it arranged close to the face or surface of the hinge-arm.

8. The combination of a main frame and arm-rest located above the seat-cushion, a curved plate curved from a center below the plate and arranged under said arm-rest and having recesses or holes transversely to its length, a movable seat-back, a hinge-arm connecting the middle of the seat-back with the main frame below the curved plate, and a locking-bolt carried wholly by the hinge-arm near its upper part and having a horizontally or transversely movable bolt for making locking connection with the plate under the arm-rest.

9. The combination of a main frame and seat-cushion, a curved plate secured to the seat-arm having a locking recess or hole at each end and curved from a center below the plate, a reversible seat-back independent of the seat-cushion, a hinge-arm pivoted at one end to the middle of the back and at the other end to the main frame below the curved plate, and a laterally-movable spring locking-bolt carried by the hinge-arm and in line with the curved guide.

10. In a car or other seat, the combination of the rigid main frame, a reversible seat-back independent of the seat-cushion, the hinge-

arms pivoted to the main frame and permanently connected at their upper ends to the seat-back, stationary or fixed arms secured to the main frame and provided with a continuous guide having stops to limit the throw of the hinge-arms, hand-operated catches carried by the hinge-arms to secure said hinge-arms to said stops, and a sliding connection between the hinge-arms and guides.

10 11. In a car or other seat, the combination of the rigid main frame having an arm-rest provided with a continuous guide, a reversible seat-back reversible on its hinge-arms, a hinge-arm permanently pivoted to the middle of the  
15 back and also to the main frame, and a catch carried by the hinge-arm and engaging with

lugs or stops on the guide to hold said hinge-arm in different positions in the guide.

12. In a car or other seat, the combination of the main or stationary frame-work, a reversible seat-back independent of the seat-cushion, hinge-arms pivoted to the main frame and to the middle of the seat-back, and a movable locking-bolt carried by the hinge-arm to lock it to the main frame-work.

25 In testimony of which invention I hereunto set my hand.

HENRY S. HALE.

Witnesses:

JNO. B. KILBURN,  
J. WARREN HALE.