

(No Model.)

J. J. DALY.

FRICITION CLUTCH AND PULLEY.

No. 250,892.

Patented Dec. 13, 1881.

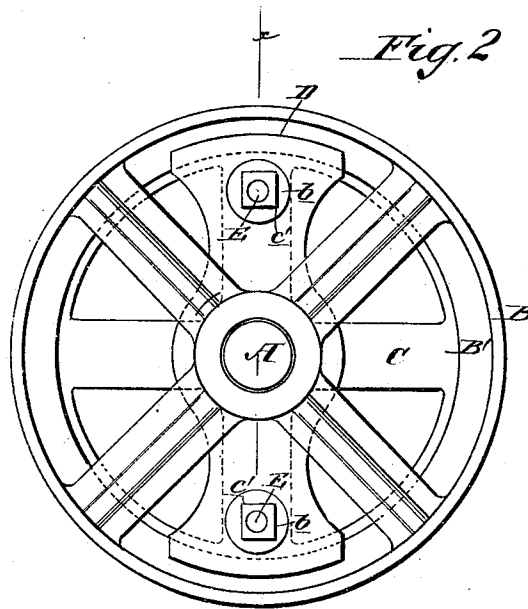
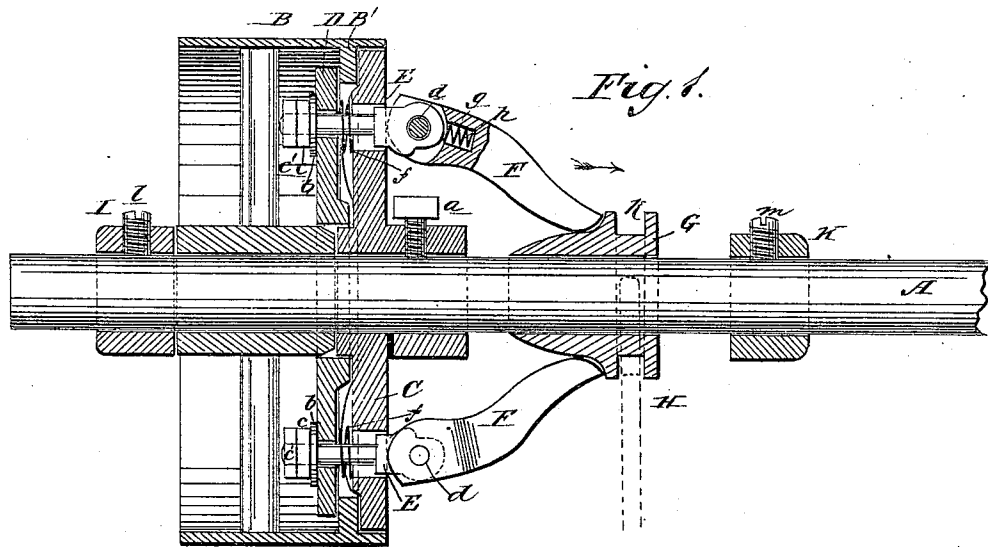

WITNESSES:
Francis McArdle.
C. Sedgwick

INVENTOR:
J. J. Daly
BY *Munn Ho*
ATTORNEYS.

UNITED STATES PATENT OFFICE.

JOHN J. DALY, OF BOSTON, MASSACHUSETTS.

FRICITION CLUTCH AND PULLEY.

SPECIFICATION forming part of Letters Patent No. 250,892, dated December 13, 1881.

Application filed June 13, 1881. (No model.)

To all whom it may concern:

Be it known that I, JOHN J. DALY, of Boston, in the county of Suffolk and State of Massachusetts, have invented a new and Improved Friction Clutch and Pulley, of which the following is a specification.

The object of this invention is to provide a simple, inexpensive, durable, and more easily applied friction-clutch for pulleys, gear-wheels, &c.

In the accompanying drawings, Figure 1 is a longitudinal partly-sectional elevation of the device on line *x x*, Fig. 2, with parts broken away to exhibit other parts. Fig. 2 is a plan of the reverse of the same.

Similar letters of reference indicate corresponding parts.

In the drawings, A represents a shaft, and B a loose pulley, fitted thereon and provided with an annular flange, B', on the inside of its rim, near one edge thereof.

C represents an annular disk or ring, secured on the shaft A by set-screw *a*, and fitted within the rim of the pulley B, with its face in contact, or nearly so, with the outer face of the flange B'; and D is the cross-bar, fixed loosely upon the shaft A, with the inner faces of its ends in contact, or nearly so, with the inner face of the flange B'.

E E are two bolts passing through said disk C and bar D, having washer *b* and nuts and check-nuts *c c'* on one end, while the opposite ends, that project above the disk C, are perforated, as shown at *d*, and have pivoted upon them the cams F, whose eccentric ends bear upon the face of the ring C, while their free curved ends rest against the thimble G, on opposite sides thereof.

Between the ring or disk C and bar D are spiral springs *f f*, to hold the two apart, and in sockets *g g* in the eccentric ends of the cams F are springs *h h*, that bear upon the heads of the bolts E and hold said cams F from contact with the disk or ring C.

Encircling the shaft A is the conical thimble G, having an annularly-grooved flange, *k*, for the accommodation of the shifting-bar H, which latter is indicated in dotted lines in Fig. 1.

The pulley B is prevented from moving on

the shaft A in one direction by the fixed disk or ring C, and in the other direction by a collar, I, that is secured on the shaft A by a set-screw, *l*, and on said shaft A, beyond the thimble G, a collar, K, is secured by a set-screw, *m*, whereby the thimble G is retained in place.

In the position shown in Fig. 1 the thimble G has been forced by the shifting-bar H between the free ends of the cams F, whereby their eccentric ends are pressed in contact with the disk or ring C as a fulcrum, thereby drawing the bar D tightly up against the pulley-flange B' and pressing the latter against the inner face of said ring C, so that the friction of bar D and ring C causes the pulley B to stop its free motion and to move with the shaft A. On moving the thimble G in the direction of the arrow, Fig. 1, the eccentric ends of the cams F are released from contact with the ring C, and the bar D thereby released from contact with the pulley-flange B', so that said pulley B again is free to move loosely on shaft A. By adjusting the nuts *c c'* on the bolts E E the tension on said bolts E E from the cams F, and consequently the friction on the pulley B from the ring and bar C D, may be regulated.

This device can be advantageously applied to lathes, planing-machines, and various other tools and mechanisms.

Having thus fully described my invention, I claim as new and desire to secure by Letters Patent—

1. An improved friction clutch and pulley constructed substantially as herein shown and described, consisting of internally-flanged loose pulley B, fixed ring or disk C, and loose bar D, held together by bolts and nuts E E *c c'*, eccentric cams F, and sliding thimble G, all on shaft A, arranged as set forth.

2. In a friction clutch and pulley, the combination, with the clamping-bolts E E, of the pivoted cams F, having sockets *g g*, containing springs *h h*, substantially as herein shown, and for the purpose described.

JOHN J. DALY.

Witnesses:

SYLVENUS WALKER,
E. A. ROBBINS.