

G. W. DICKINSON.

Improvement in Paddle-Wheels.

No. 132,641.

Patented Oct. 29, 1872.

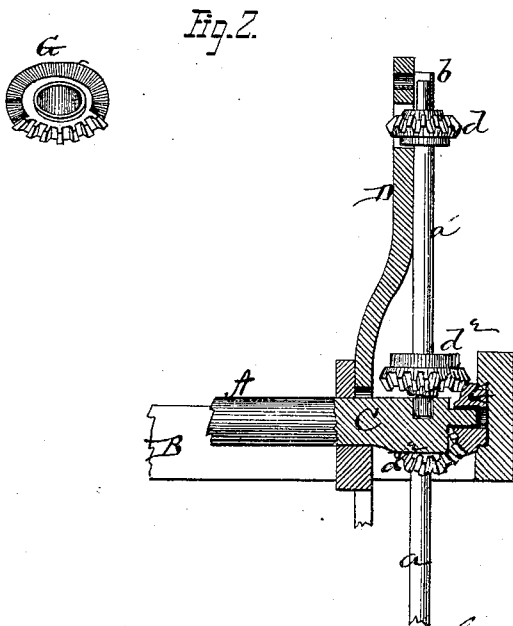
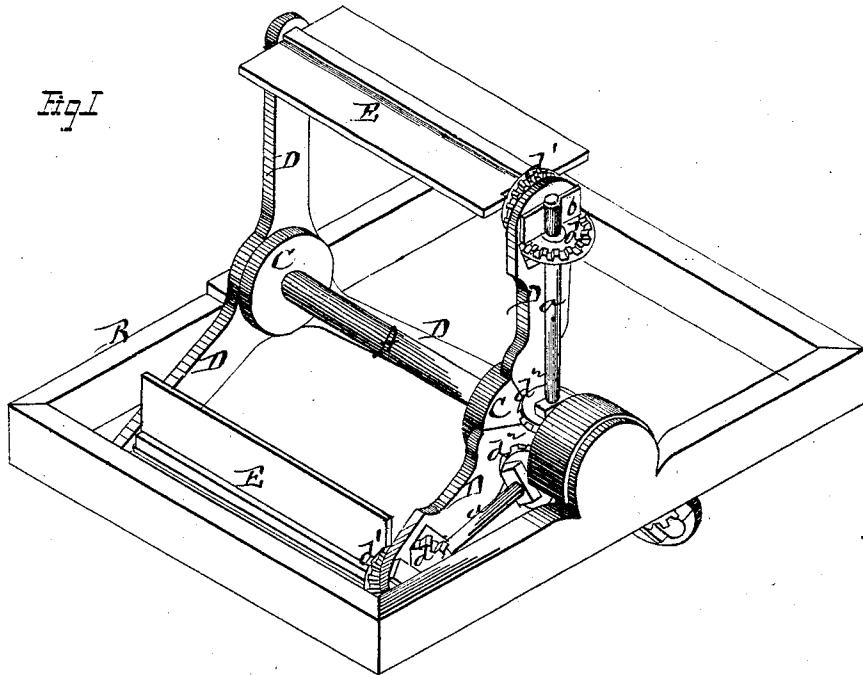

Witness:
Jas. C. Hutchinson
C. L. Evert

Inventor.
George W. Dickinson.
per. H. A. Mason

Attorneys.

UNITED STATES PATENT OFFICE.

GEORGE W. DICKINSON, OF CHARLESTON, ILLINOIS.

IMPROVEMENT IN PADDLE-WHEELS.

Specification forming part of Letters Patent No. 132,641, dated October 29, 1872.

To all whom it may concern:

Be it known that I, GEO. W. DICKINSON, of Charleston, in the county of Coles, and in the State of Illinois, have invented certain new and useful Improvements in Paddle-Wheel; and do hereby declare that the following is a full, clear, and exact description thereof, reference being had to the accompanying drawing and to the letters of reference marked thereon making a part of this specification.

The nature of my invention consists in the construction and arrangement of certain devices for holding the paddles or buckets in an upright position while in the water, as will be hereinafter more fully set forth.

In order to enable others skilled in the art to which my invention appertains to make and use the same, I will now proceed to describe its construction and operation, referring to the annexed drawing, in which—

Figure 1 is a perspective view of my paddle-wheel, and Fig. 2 is a section of the same.

A represents the central shaft, having its bearings in a suitable frame, B. At or near each end of the shaft A is a hub, C, with radiating arms D D, in the outer ends of which the journals of the paddles or buckets E E have their bearings. On the outer side of each arm D, at one end of the shaft A, is a shaft, *a*, running lengthwise with the arm and having its inner bearing in a prolongation of the hub C, while its outer bearing is a band or

box, *b*, attached to the arm. Near the outer end of this shaft is a miter or beveled cog-wheel, *d*, which projects through an opening in the arm, and meshes with a similar wheel or pinion, *d*¹, on the journal of the paddle or bucket E. Upon the inner end of the shaft *a* is another miter wheel or pinion, *d*², which meshes with a half cog-wheel, G, attached around the bearing of the shaft A. The cogs of the wheel G are located at its lower half, so that when the bucket enters the water the pinion *d*² will commence to mesh with the wheel G, and when the buckets rise from the water the pinion will be out of gear. The effect is to keep the buckets or paddles in an upright position while in the water, the paddles or buckets striking or entering the water edgewise and coming out in the same position.

Having thus fully described my invention, what I claim as new, and desire to secure by Letters Patent, is—

In a paddle-wheel, the combination of the main shaft, radial arms, and bevel-gearing, substantially as described, for operating the buckets, as set forth.

In testimony that I claim the foregoing I have hereunto set my hand this 23d day of August, 1872.

GEORGE W. DICKINSON.

Witnesses:

J. S. McDANIEL,
WM. R. HIGHLAND.