

(No Model.)

R. F. COLEMAN.  
IRONING TABLE.

No. 529,481.

Patented Nov. 20, 1894.

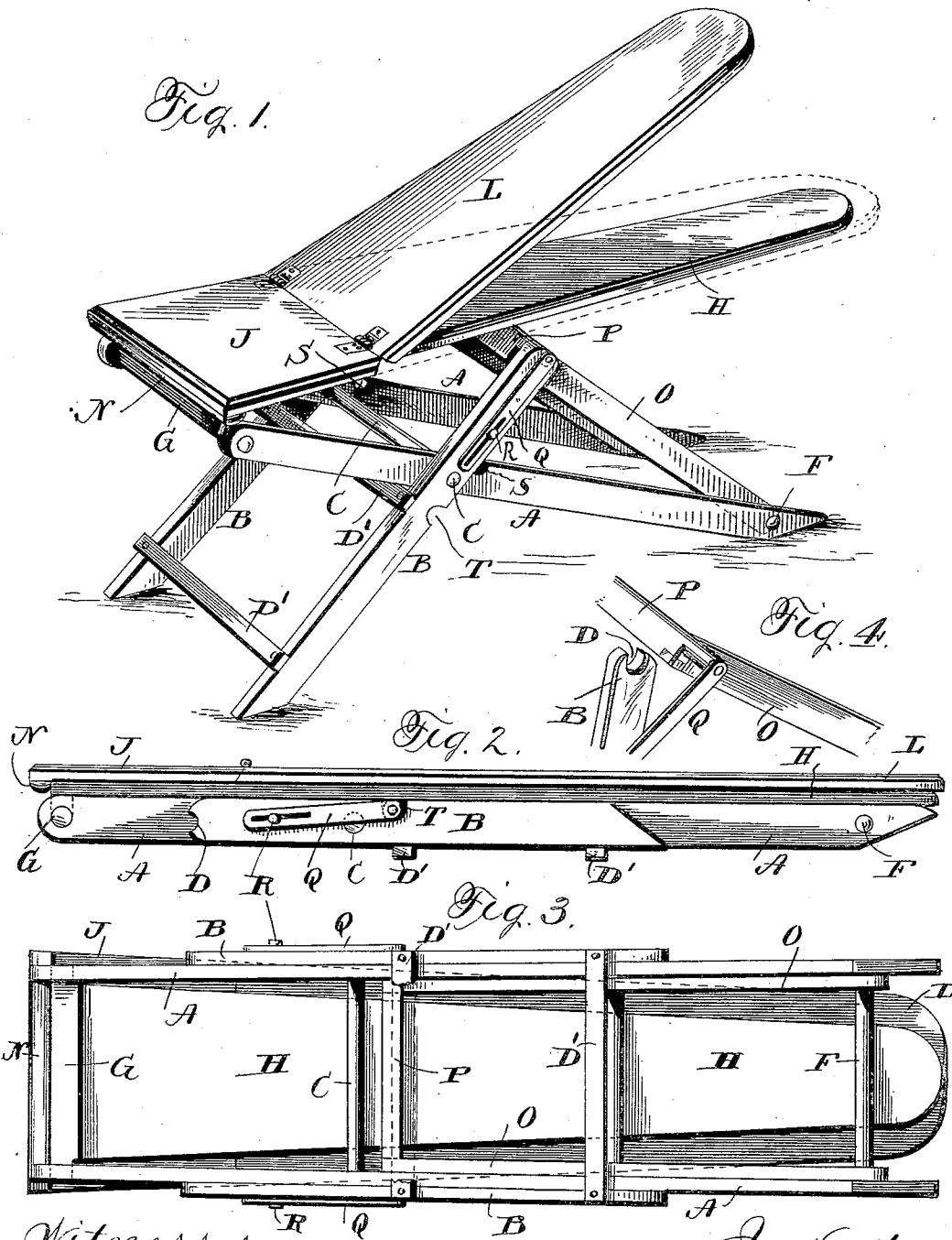

Witnesses  
 J. Williamson  
 F. A. Schmann

Inventor  
 Robert F. Coleman,  
 by Franklin N. Hough,  
 attorney

# UNITED STATES PATENT OFFICE.

ROBERT FRANKLIN COLEMAN, OF OVERTON, TEXAS.

## IRONING-TABLE.

SPECIFICATION forming part of Letters Patent No. 529,481, dated November 20, 1894.

Application filed August 29, 1894. Serial No. 521,613. (No model.)

*To all whom it may concern:*

Be it known that I, ROBERT FRANKLIN COLEMAN, a citizen of the United States, residing at Overton, in the county of Rusk and State of Texas, have invented certain new and useful Improvements in Ironing-Tables; and I do declare the following to be a full, clear, and exact description of the invention, such as will enable others skilled in the art to which it appertains to make and use the same, reference being had to the accompanying drawings, and to the letters of reference marked thereon, which form a part of this specification.

My invention relates to an improvement in folding ironing tables.

My aim is to produce a folding ironing table, having its top pivoted to the longer of two pairs of legs, the shorter pair designed to hold a cross bar which is adapted to support the table top about midway its length, when the table is opened and set up for use; and the invention consists in the novel construction, combination and adaptation of the parts as will be hereinafter more fully described, and then specifically defined in the appended claims.

In the accompanying drawings, Figure 1 is a perspective view of a folding ironing table which embodies my invention. Fig. 2 is a side elevation showing the parts closed. Fig. 3 is an inverted view of the table showing it closed. Fig. 4 is a detail view.

A represents the longer pair of legs, and B the shorter pair, and which are pivoted together by means of the pivotal rod C in the usual manner. To the shorter pair of legs, which are provided with the notches or recesses D in their upper ends, are secured the two brace rods D', the upper one of which serves to limit the movement of the two pairs of legs when being opened for use. The lower ends of the longer legs are secured together by means of the rod F, which also serves as a pivot upon which the support turns, and the upper ends of the legs are connected by the pivoted cross bar G which is rigidly secured to the under side of one end of the narrow ironing board H. Rigidly secured upon the upper side of the pivoted end of the narrow board H, is a short board J to which the wider ironing board L is hinged. Across the under

side of the short board J, which extends beyond the pivoted end of the narrow ironing board is a cleat N, which serves to brace and strengthen this board and prevent it from warping or splitting. The wider board is hinged and placed above the narrower one, so that when it is desired to use the narrow one alone the wider board can be turned up or back out of the way, so as to leave the narrow one entirely unobstructed.

The support O, which is pivoted at its lower end upon the bar F has secured to its upper end the cross bar P, which extends beyond the sides of the support O, and the ends of this cross bar are reduced in size so as to fit in the notches in the upper ends of the short legs when the parts are in position ready for use. The ends of this cross bar are connected to the upper ends of the short legs by means of the slotted plates Q. These plates are pivoted at their upper ends to the ends of the cross bar and they are loosely connected at their lower slotted ends to the sides of the short legs by means of the headed bolts or pins R which extend through the slots to allow freedom of motion to the plates when the table is being folded together, as shown in Figs. 2 and 3.

When the table is not wanted for immediate use, or is to be closed for transportation the support fits down inside of the longer pair of legs, the shorter pair closes outside of and in a line with the longer pair, the two braces D' resting against the inner edges of the longer pair of legs as shown. The reduced ends of the cross bar P, which are long enough to extend to the outside edge of the short legs rest in the notches S, made in the upper edges of the long legs and the notches T made in the inner edge of the short legs, and these notches being made upon opposite sides of the pivot come together, when the table is closed.

In opening the table for use, the raising of the free end of the support causes the shorter legs B to turn upon their pivots and bring their notched upper ends into position to receive the reduced ends of the cross bar, and this cross bar serves to lock the two pairs of legs in position, so that they cannot accidentally close, no matter to what use the table may be put until the cross bar is raised out

of the notches. The two boards resting upon the top of this bar hold it in the notches in the short legs, and hence prevent any possibility of the parts closing while in use. The  
5 greater the pressure upon the boards the more securely the legs are locked in place.

Having thus described my invention, I claim—

1. In a folding ironing table, the two sets of  
10 legs of unequal length, an ironing board pivoted to the longer pair of legs, a pivoted support for the board, and slotted plates connected both to the support and to the upper end of the shorter pair of legs, all combined,  
15 substantially as specified.

2. In an ironing table, the two pairs of legs of unequal length suitably connected and pivoted together, combined with the pivoted ironing board, the support pivoted between the longer pair of legs, the cross bar secured to its  
20 end, and the slotted plates loosely connected both to the ends of the cross bar and to the shorter pair of legs, substantially as shown and described.

In testimony whereof I affix my signature in  
25 presence of two witnesses.

ROBERT FRANKLIN COLEMAN.

Witnesses:

C. C. LEVERETT,  
J. E. ARNOLD.