

(19)



Europäisches Patentamt
European Patent Office
Office européen des brevets



(11)

EP 1 065 437 A3

(12)

EUROPEAN PATENT APPLICATION

(88) Date of publication A3:
30.10.2002 Bulletin 2002/44

(51) Int Cl.7: **F21S 8/10, F21V 14/02**
// F21W101:10

(43) Date of publication A2:
03.01.2001 Bulletin 2001/01

(21) Application number: **00305444.2**

(22) Date of filing: **28.06.2000**

(84) Designated Contracting States:
AT BE CH CY DE DK ES FI FR GB GR IE IT LI LU
MC NL PT SE
Designated Extension States:
AL LT LV MK RO SI

- **Vejbor, Petr**
Olomouc 779 00 (CZ)
- **Strambersky, Libor**
Senov U Noveho Jicina 742 42 (CZ)
- **Specka, Jaroslav**
Nove Mesto Nad Metuji 549 01 (CZ)

(30) Priority: **29.06.1999 CZ 235299**

(71) Applicant: **AUTOPAL S.R.O.**
Novy Jicin 741 01 (CZ)

(74) Representative: **Godwin, Edgar James**
MARKS & CLERK,
57-60 Lincoln's Inn Fields
London WC2A 3LS (GB)

(72) Inventors:
• **Cejnek, Milan**
Novy Jicin 741 01 (CZ)

(54) **Headlight system for motor vehicles**

(57) A headlight system for motor vehicles which comprises a reflector (1), a light source (2), an opaque shield (9) and an actuating member, which member provides for changing of the light source (2) position be-

tween the position for the low light beam mode and that for the high light beam mode, whereby the light source (2) is mounted in this actuating member and the resulting force vector induced by this actuating member is situated in proximity of the light source (2) alone.

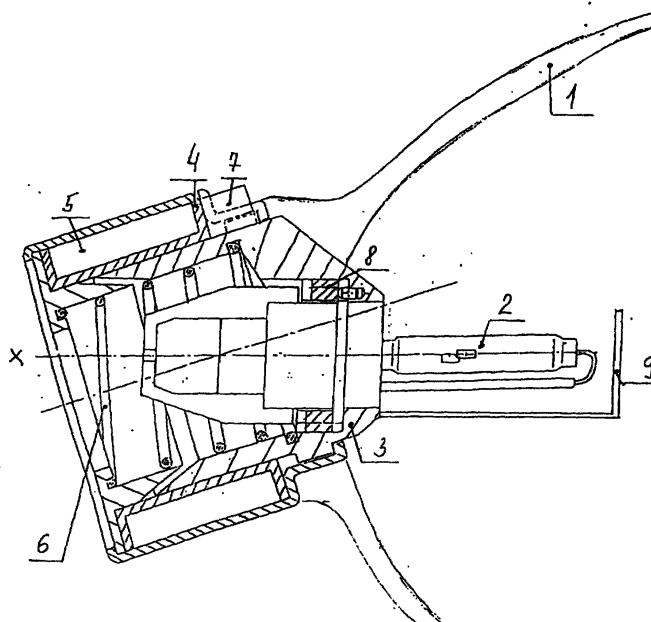

EP 1 065 437 A3

**ANNEX TO THE EUROPEAN SEARCH REPORT
ON EUROPEAN PATENT APPLICATION NO.**

EP 00 30 5444

This annex lists the patent family members relating to the patent documents cited in the above-mentioned European search report. The members are as contained in the European Patent Office EDP file on
The European Patent Office is in no way liable for these particulars which are merely given for the purpose of information.

04-09-2002

Patent document cited in search report		Publication date	Patent family member(s)	Publication date
EP 0942224	A	15-09-1999	IT T0980197 A1	10-09-1999
			EP 0942224 A1	15-09-1999
FR 96438	E	30-06-1972	NONE	
FR 1425422	A	24-01-1966	NONE	
EP 0705730	A	10-04-1996	DE 4435507 A1	11-04-1996
			DE 59508449 D1	13-07-2000
			EP 0705730 A2	10-04-1996
			JP 8111101 A	30-04-1996
			US 5769525 A	23-06-1998