

J. KEPHART.  
 HOT WATER HEATER AND CIRCULATOR.  
 APPLICATION FILED SEPT. 2, 1909.

974,890.

Patented Nov. 8, 1910.

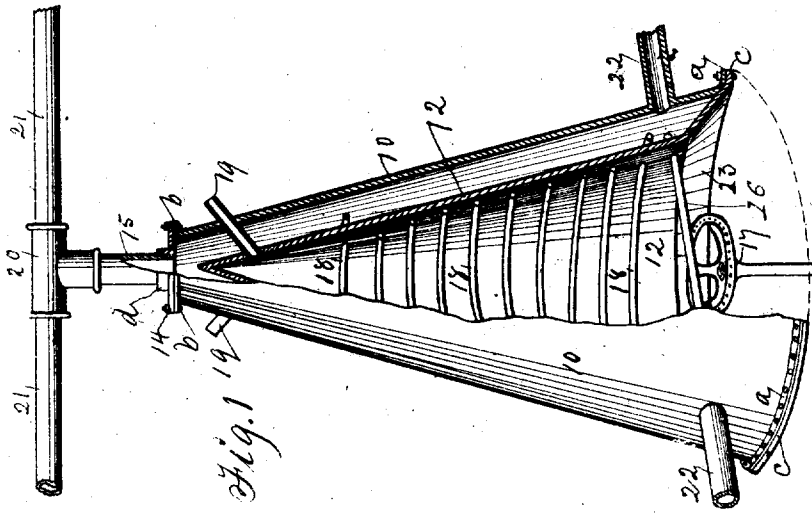
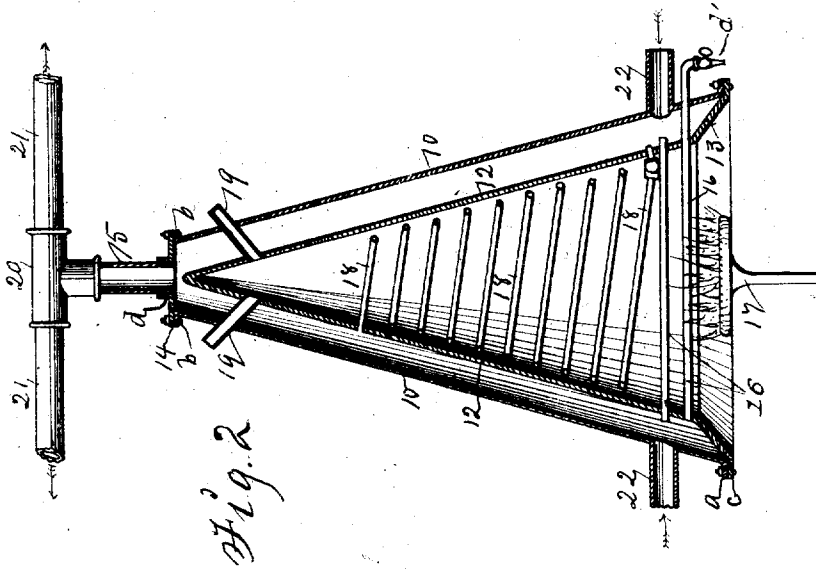

Witnesses:  
 E. W. Miller  
 F. C. Woodard

Inventor: James Kephart,  
 By Thomas G. Orwig & Co. Attorneys

# UNITED STATES PATENT OFFICE.

JAMES KEPHART, OF WEBSTER CITY, IOWA.

HOT-WATER HEATER AND CIRCULATOR.

974,890.

Specification of Letters Patent.

Patented Nov. 8, 1910.

Application filed September 2, 1909. Serial No. 517,147.

To all whom it may concern:

Be it known that I, JAMES KEPHART, a citizen of the United States, residing at Webster City, in the county of Hamilton and State of Iowa, have invented a new and useful Hot-Water Heater and Circulator, of which the following is a specification.

The object of this invention is to provide improved means for heating and circulating water.

My invention consists in the construction, arrangement and combination of elements hereinafter set forth, pointed out in my claims and illustrated by the accompanying drawing, in which—

Figure 1 is a perspective, partly in section, of my improved device. Fig. 2 is a vertical section centrally of the device.

In the construction of the apparatus as shown I employ a boiler composed of outer and inner walls 10, 12 and their connections. The outer wall 10 preferably is shaped as a truncated cone and is formed with a peripheral flange *a* at its bottom and a smaller peripheral flange *b* at its top. The inner wall 12 is formed as a cone, closed at its top and having a rim 13 at its base flared at an angle to the wall and constructed with a peripheral flange *c* corresponding in size with and adapted to be riveted to the flange *a* of the outer wall. The connection as shown between the flanges *a* and *c* serves to support the inner wall 12 in concentric relation to the outer wall 10 and also serves to close the bottom of the boiler. The space between the inner and outer walls is adapted to contain water. A cover 14 is fixed and sealed to the flange *b* of the outer wall 10 and is provided with an integral vertical tube *d* in which is sealed a pipe 15, said pipe communicating through said cover with the interior of the outer wall 10. A plurality of straight open-ended pipes 16 are mounted diametrically of the inner wall 12 and communicate at their ends through said wall with the space between the walls. One of the pipes 16 may be extended across the water space between the walls and through the lower portion of the outer wall 10 and be closed when desired by a faucet *d'*. To avoid confusion in the drawing I show one only of the pipes 16 open at its ends to the water space between the walls of the boiler. A gas burner 17 preferably is located centrally and within the base of the boiler and discharges its products of combustion, when

ignited, within the lower end portion of the inner wall 12. A spirally shaped pipe 18 is mounted within and in proximity to the inner surface of the inner wall 12 and extends from the bottom of said wall nearly to the top thereof. The spirally shaped pipe 18 communicates at one end through the inner wall 12 with the lower portion of the water space in the boiler and communicates at its upper end through said inner wall with the upper portion of the water space in the boiler. Vent tubes 19 are mounted in inclined positions in and extend through the upper portions of the walls, 10, 12 of the boiler and across the water space therein. The vent tubes 19 are open at their ends and are adapted to discharge products of combustion from the interior of the inner wall 12. A tee 20 is mounted on the upper end portion of the pipe 15 and pipes 21 lead from a lining ports of said tee and are adapted to be connected to radiators not shown. Pipes 22 are mounted in the lower portion of the outer wall 10 of the boiler and communicate with the water space within the boiler near the bottom thereof. The pipes 22 are adapted to lead from radiators not shown. It is the function of the pipes 21 to lead hot water to points of use and it is the function of the pipes 22 to return cooled water to the boiler. Thus in the use of the boiler and pipes as shown, together with the conventional use of radiators, not shown, a circulation for the water is provided and through the use of the gas burner and pipes 16, 18, together with the peculiar shape of the boiler, provision is made for heating such water and initiating and maintaining the circulation thereof through the medium provided.

What I claim as new and desire to secure by Letters-Patent, is:

1. A hot water heater comprising, in combination, an outer truncated cone, an inner cone secured to said truncated cone at its base only and held in concentric relation thereto, inlets at the bottom of said outer truncated cone and an outlet at its top, a burner below said cone and vents at its upper end extending outwardly and upwardly through said truncated cone, and a conical coil lying closely against the inner surface of said cone and communicating at its ends with the space between said outer and inner cones.
2. A hot water heater, comprising, in com-

5 bination, an outer truncated cone, an inner cone secured to said truncated cone at its base only and held in concentric relation thereto, inlets at the bottom of said outer truncated cone and an outlet at its top, a burner below said cone and vents at its upper end extending outwardly and upwardly through said truncated cone, a conical coil lying closely against the inner surface of

said cone and communicating at its ends 10 with the space between said outer and inner cones, and a plurality of diametrically disposed pipes spanning the base of said inner cone and communicating with said space.

JAMES KEPHART.

Witnesses:

WILL. L. CLIFTON.

E. E. MASON.