

(12) INTERNATIONAL APPLICATION PUBLISHED UNDER THE PATENT COOPERATION TREATY (PCT)

(19) World Intellectual Property Organization  
International Bureau



(43) International Publication Date  
21 November 2002 (21.11.2002)

PCT

(10) International Publication Number  
**WO 02/092932 A1**

(51) International Patent Classification<sup>7</sup>: **E04B 1/80**,  
E04C 2/292, B32B 19/04

(21) International Application Number: PCT/FI02/00395

(22) International Filing Date: 8 May 2002 (08.05.2002)

(25) Filing Language: Finnish

(26) Publication Language: English

(30) Priority Data:  
20010992 11 May 2001 (11.05.2001) FI

(71) Applicant (for all designated States except US): **PAROC GROUP OY AB** [FI/FI]; Neilikkatie 17, FIN-01300 Vantaa (FI).

(72) Inventors; and

(75) Inventors/Applicants (for US only): **HESELIUS, Lars** [FI/FI]; Kullasgränd, FIN-21600 Pargas (FI). **WILLMAN, Tarmo** [FI/FI]; Laskuttajankatu 16, FIN-20780 Kaarina (FI). **LYNDERUP, John** [DK/DK]; Mosede Klintvej 29, DK-2670 Greve Strand (DK). **KARLSSON, Dick** [FI/FI]; Kapteeninaukio 2, FIN-21600 Parainen (FI).

(74) Agent: **LEITZINGER OY**; Tammasaarenkatu 1, FIN-00180 Helsinki (FI).

(81) Designated States (national): AE, AG, AL, AM, AT (utility model), AT, AU, AZ, BA, BB, BG, BR, BY, BZ, CA, CH, CN, CO, CR, CU, CZ (utility model), CZ, DE (utility model), DE, DK (utility model), DK, DM, DZ, EC, EE (utility model), EE, ES, FI (utility model), FI, GB, GD, GE, GH, GM, HR, HU, ID, IL, IN, IS, JP, KE, KG, KP, KR, KZ, LC, LK, LR, LS, LT, LU, LV, MA, MD, MG, MK, MN, MW, MX, MZ, NO, NZ, OM, PH, PL, PT, RO, RU, SD, SE, SG, SI, SK (utility model), SK, SL, TJ, TM, TN, TR, TT, TZ, UA, UG, US, UZ, VN, YU, ZA, ZM, ZW.

(84) Designated States (regional): ARIPO patent (GH, GM, KE, LS, MW, MZ, SD, SL, SZ, TZ, UG, ZM, ZW), Eurasian patent (AM, AZ, BY, KG, KZ, MD, RU, TJ, TM), European patent (AT, BE, CH, CY, DE, DK, ES, FI, FR, GB, GR, IE, IT, LU, MC, NL, PT, SE, TR), OAPI patent (BF, BJ, CF, CG, CI, CM, GA, GN, GQ, GW, ML, MR, NE, SN, TD, TG).

**Published:**

— with international search report

For two-letter codes and other abbreviations, refer to the "Guidance Notes on Codes and Abbreviations" appearing at the beginning of each regular issue of the PCT Gazette.

(54) Title: SANDWICH BUILDING ELEMENT

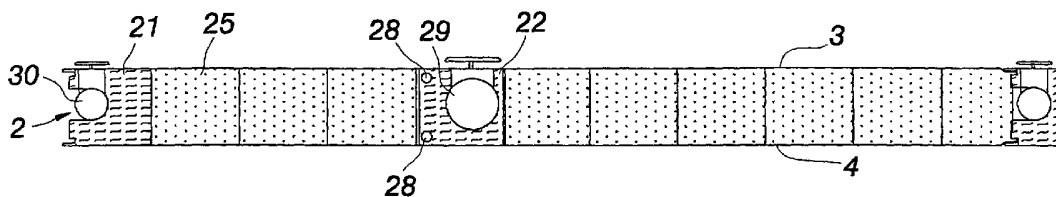

(57) Abstract: The invention relates to a sandwich building element, comprising a core member (2), and surface layers (3, 4) present on its two opposite main surfaces. The core member is composed of lamellae of mineral wool extending lengthwise of the building element. The surface layers are laminated on the core member by fixing the same with an adhesive to the opposite main surfaces of the core member. The core member (2) consists of at least two lamellae (20, 25, 41, 42) different from each other in items of their fire resistance, strength, and/or other properties.



WO 02/092932 A1

## Sandwich building element

The present invention relates to a sandwich building element, comprising a core member, and surface layers present on its two opposite main surfaces, said  
5 core member being composed of lamellae of mineral wool extending lengthwise of the building element, said surface layers being laminated on the core member by fixing the same with an adhesive to the opposite main surfaces of the core member.

10 It is an object of the present invention to provide an improved sandwich building element, which enables e.g. appropriate planning of junctions, e.g. from the perspective of fireproofing and strength requirements, and which building element is fit for versatile use in various applications, enabling e.g. the  
15 installation of various air ducts and pipe systems required by electric cables within the confines of a wall composed of the building elements. In order to fulfil this objective, the inventive building element is characterized in that at least one lamella has integrated therewith at least one separate LVIST (heating, plumbing, ventilation, electrical installation and transmission of information)  
20 duct element and/or structural support member, and that the building element is capable of being bonded to an adjacent building element in such a way that said duct element and/or structural support member becomes continuous across a junction between the building elements. The term LVIST duct element refers to a duct or channel associated with heating, water supply service, air  
25 conditioning, transmission of electricity, or transmission of information.

One of the benefits gained by a building element of the invention is e.g. that desired parts in the core member of a building element can be provided with desired properties, e.g. one or each of the skirt lamellae may have more strength or rigidity or a better fire resistance than centrally located lamellae, the

core member manufacturing costs remaining lower than those for a core member made entirely of a higher-quality material. In addition, according to the invention, it is comparatively easy to manufacture profiled building elements by using lamellae with sizes varying in the direction perpendicular to the building  
5 element.

The inventive building element provided with various duct and/or structural support members enables e.g. the implementation of intelligent facades and removable partitions in a comparatively simple fashion.  
10

The lamellae can also have other elements integrated therewith, such as e.g. sound proofing panels for enhanced sound attenuation. The lamellae can also have integrated therewith a fastener or a bracket member applied against the internal face of a surface plate for various engagement requirements. Said  
15 fastener or bracket member adheres securely to the internal face of a surface panel in the process of bonding lamellae to the surface panel.

The invention will now be described in more detail with reference to the accompanying drawings, in which:  
20

Figs. 1a-1d illustrate schematically a few alternative embodiments for a building element, and

Fig. 2 shows a building element embodiment, particularly applicable as a ceiling panel.  
25

In fig. 1a, one skirt lamella 20 is constructed from a mineral wool material which is stronger and better in terms of its fire-proofing or refractory properties than that used for other lamellae 25 of the core member, in view of reinforcing

a junction between building elements to be joined together. The lamella section 20 has additionally ducts or pipe systems 28 integrated therewith, e.g. for electric cables.

- 5 In fig. 1b, in addition to a skirt lamella 21, a centrally located lamella 22 is also made from a stronger mineral wool material than lamellae 25 and, furthermore, the skirt lamella 21 has an air duct 30 integrated therewith, and the lamella section 22 has an air duct 29 and channels or pipe systems 28 integrated therewith for electric cables. Regarding the material therefor, the air ducts  
10 and/or other channels or pipe systems can be made e.g. of a metal or plastics and integrated with a lamella preferably by bonding.

In fig. 1c, the skirt lamella 23 has integrated therewith a provision 31 for housing, for example, building frame members in concealment within a wall  
15 structure. The skirt lamella 23 is made of a material stronger than the other lamellae 25.

Fig. 1d illustrates an embodiment, wherein an outermost lamella 24 is formed with a provision 32 for housing cable pipe systems 28 and, in addition, the core  
20 member has a centrally located lamella element 22 provided with an air duct 29 and pipe systems 28 for electric cables. Further in the embodiment of fig. 1d, the surface layer material consists of building board thicker than that used in the embodiments of figs. 1a-1c, in which the surface layer material comprises preferably plastic-coated sheet steel. Surface layer materials 26 and 27 may  
25 comprise e.g. a board including rock material or a plaster board.

Fig. 2 illustrates a building element 40 suitable for use as a ceiling panel, wherein the core member 2 has its lamellae designed in such a way that the core member has a bottom main surface which is flat and a top main surface

which is profiled. Profiling is normally made by using lamellae substantially equal in size to begin with, and by then forming the surface of a core member with cross-sectionally V- or U-shaped grooves 43, for example by cutting or milling. The grooves 43 can also be formed by adding suitably shaped blocks  
5 onto the surface of the core member 2. Reference numeral 41 represents a lamella section provided with a flat top surface, and reference numeral 42 a lamella section provided with a groove 43. As a result of the groove system 43, the dimensions of these lamella sections vary in the direction perpendicular to the element 40 and, in the present embodiment, in the lateral direction, as well.  
10 Naturally, the groove system 43 can also be made in such a way that the lamella section 41 has a flat top surface which, in a lateral direction of the element, is equal in size to the width of the opening of the groove 43. The top surface layer 3 is designed to be substantially consistent with the profiled contour of the corresponding main surface of the core member 2.

15 The inventive building elements can be fabricated on a conventional continuous-action line for producing long series of identical elements, or on a so-called semi-continuous line which can be used for making individual elements sequentially in short series, even single pieces. Said semi-continuous method is  
20 described in more detail in a co-pending Finnish application filed by the present Applicant on the same date. In this method, the surface layer 3 and 4 applied to each main surface of the core member 2 is sequentially and temporarily bonded to other surface layers 3 and 4 applied to the corresponding main surfaces for providing continuous strings of surface layer, said strings of surface layer being  
25 then coupled with the core member 2 for providing a continuous string of building elements. The thus obtained string of building elements is then cut at temporary junctions between the strings of surface layer. Said temporary joining is preferably performed by taping.

Regarding a building element of the invention, it is conceivable that at least one of the surface layers 3, 4 be profiled over all four sides thereof, i.e. over lengthwise edges and crosswise short sides or end zones, in view of making a cartridge element. Profiling of the end zone can also be performed by fitting

5 said zones with separate profiled end elements.

**Claims**

1. A sandwich building element, comprising a core member (2), and surface layers (3, 4) present on its two opposite main surfaces, said core member being  
5 composed of lamellae of mineral wool extending lengthwise of the building element, said surface layers being laminated on the core member by fixing the same with an adhesive to the opposite main surfaces of the core member, said core member (2) consisting of at least two lamellae (20-25, 41, 42) different  
10 from each other in terms of their fire resistance, strength, and/or other properties, **characterized** in that at least one lamella has integrated therewith at least one separate LVIST (heating, plumbing, ventilation, electrical installation and transmission of information) duct element (28, 29) and/or structural support member (31), and that the building element is capable of  
15 being bonded to an adjacent building element in such a way that said duct element (28, 29) and/or structural support member (31) becomes continuous across a junction between the building elements.
2. A building element as set forth in claim 1, **characterized** in that the core member (2) has at least one of its main surfaces made profiled by forming the  
20 same with grooves (43), and that the surface layers (3, 4) are adapted to substantially comply with the surface contour of the core member (2).
3. A building element as set forth in claim 2, **characterized** in that the grooves (43) are made by cutting or milling.  
25
4. A building element as set forth in claim 2, **characterized** in that the grooves (43) are made by adding suitably shaped blocks to the surface of the core member.

5. A building element as set forth in any of the preceding claims, **characterized** in that at least one of the surface layers (3, 4) is profiled as desired over all sides thereof.
- 5 6. A building element as set forth in claim 5, **characterized** in that profiling of the short sides (end zones) of said all-round profiled surface layer is performed by fitting the same with separate profiled end elements.

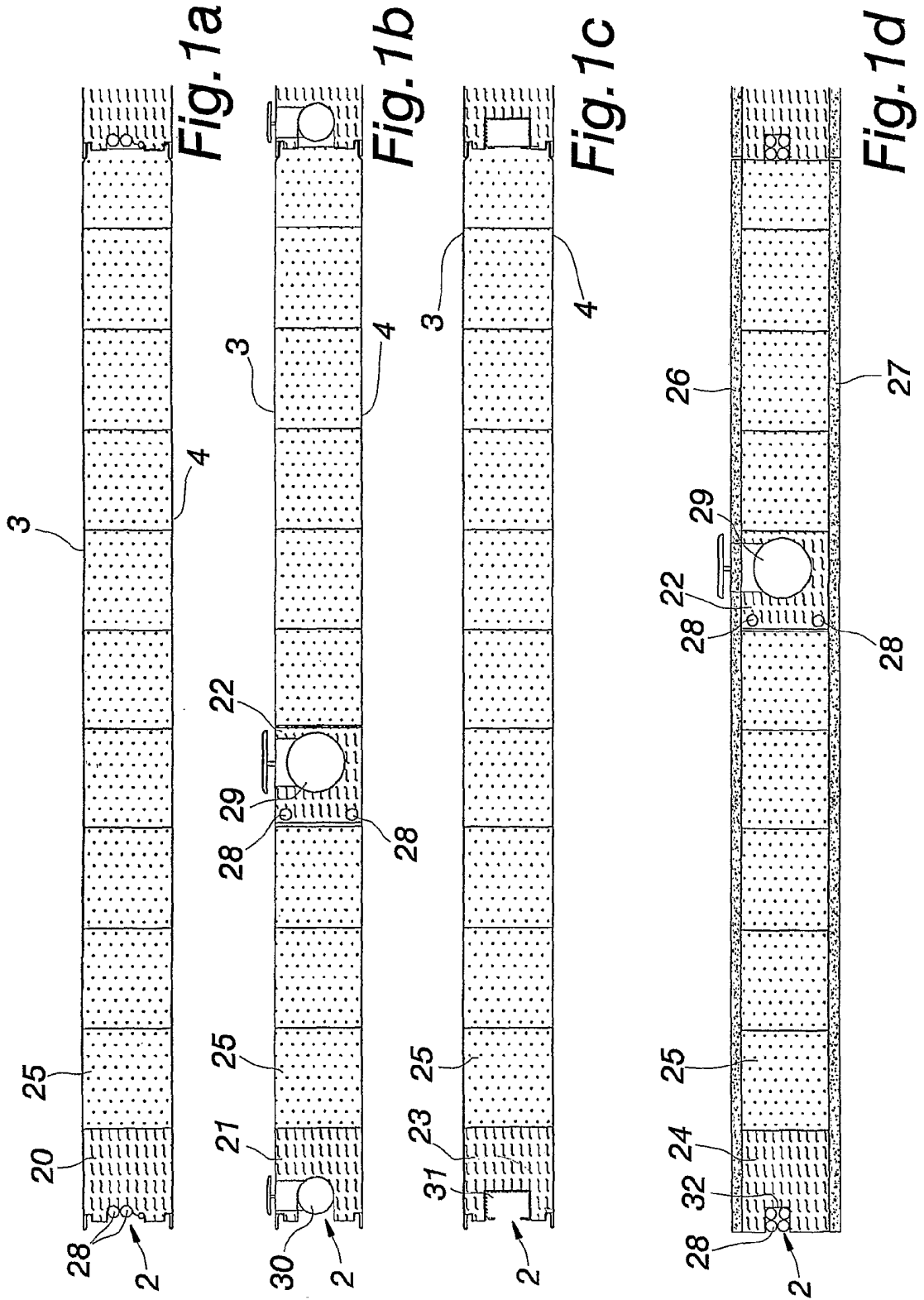

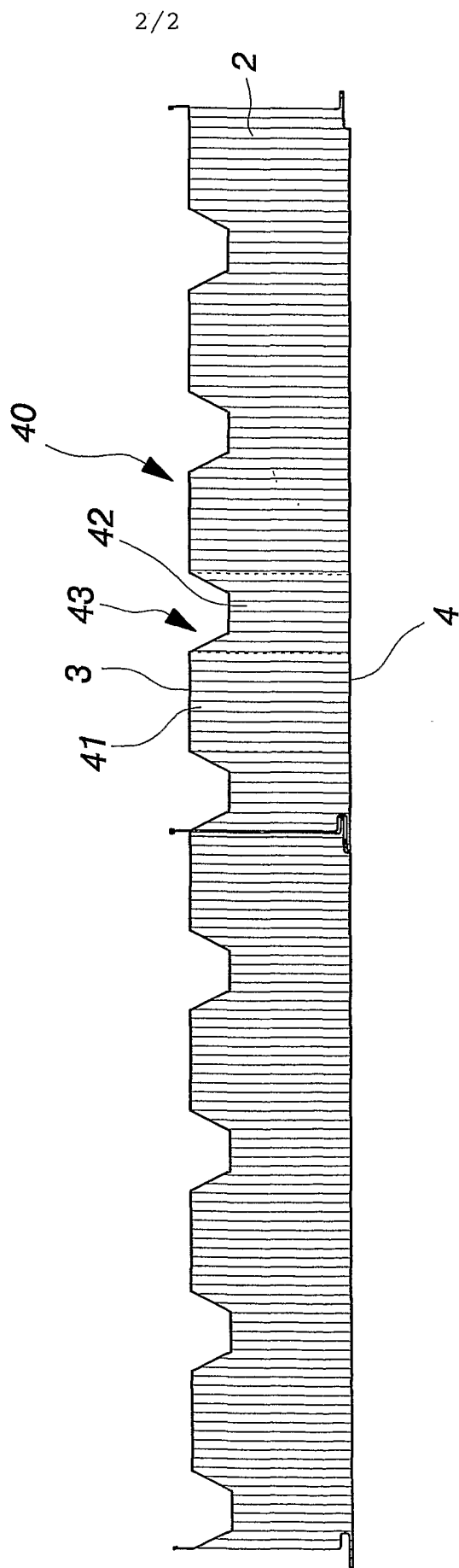

Fig.2

## INTERNATIONAL SEARCH REPORT

International application No.

PCT/FI 02/00395

## A. CLASSIFICATION OF SUBJECT MATTER

IPC7: E04B 1/80, E04C 2/292, B32B 19/04  
According to International Patent Classification (IPC) or to both national classification and IPC

## B. FIELDS SEARCHED

Minimum documentation searched (classification system followed by classification symbols)

IPC7: E04B, E04C

Documentation searched other than minimum documentation to the extent that such documents are included in the fields searched

SE,DK,FI,NO classes as above

Electronic data base consulted during the international search (name of data base and, where practicable, search terms used)

EPO-INTERNAL, WPI DATA, PAJ

## C. DOCUMENTS CONSIDERED TO BE RELEVANT

Category*	Citation of document, with indication, where appropriate, of the relevant passages	Relevant to claim No.
X	SE 506924 C2 (PLANNJA AB), 21 April 1997 (21.04.97) --	1-6
X	DE 4133416 A1 (DEUTSCHE ROCKWOOL MINERALWOLL GMBH), 15 April 1993 (15.04.93) --	1-6
X	WO 0000704 A1 (GESSNER, DIETER), 6 January 2000 (06.01.00) --	1-6
X	WO 0070161 A1 (SAINT-GOBAIN ISOVER), 23 November 2000 (23.11.00) --	1-6

Further documents are listed in the continuation of Box C.  See patent family annex.

* Special categories of cited documents:	"T" later document published after the international filing date or priority date and not in conflict with the application but cited to understand the principle or theory underlying the invention
"A" document defining the general state of the art which is not considered to be of particular relevance	"X" document of particular relevance: the claimed invention cannot be considered novel or cannot be considered to involve an inventive step when the document is taken alone
"E" earlier application or patent but published on or after the international filing date	"Y" document of particular relevance: the claimed invention cannot be considered to involve an inventive step when the document is combined with one or more other such documents, such combination being obvious to a person skilled in the art
"L" document which may throw doubts on priority claim(s) or which is cited to establish the publication date of another citation or other special reason (as specified)	"&" document member of the same patent family
"O" document referring to an oral disclosure, use, exhibition or other means	
"P" document published prior to the international filing date but later than the priority date claimed	

Date of the actual completion of the international search

9 August 2002

Date of mailing of the international search report

27 -08- 2002

Name and mailing address of the ISA/  
Swedish Patent Office  
Box 5055, S-102 42 STOCKHOLM  
Facsimile No. +46 8 666 02 86

Authorized officer

Axel Beks/EK  
Telephone No. +46 8 782 25 00

## INTERNATIONAL SEARCH REPORT

International application No.

PCT/FI 02/00395

C (Continuation). DOCUMENTS CONSIDERED TO BE RELEVANT		
Category*	Citation of document, with indication, where appropriate, of the relevant passages	Relevant to claim No.
A	DE 29714251 U1 (THÜRINGER DÄMMSTOFFWERKE GMBH), 22 January 1998 (22.01.98)  --	1-6
A	DE 7408307 U (TRAUB, TILLO), 20 June 1974 (20.06.74)  -- -----	1-6

**INTERNATIONAL SEARCH REPORT**  
Information on patent family members

06/07/02

International application No.

PCT/FI 02/00395

Patent document cited in search report			Publication date	Patent family member(s)	Publication date	
SE	506924	C2	21/04/97	FI SE	964151 A 9503692 A	21/04/97 21/04/97
DE	4133416	A1	15/04/93	DE	4143387 A,C	24/06/93
WO	0000704	A1	06/01/00	DE DE	19830066 A 29811945 U	05/01/00 21/01/99
WO	0070161	A1	23/11/00	AU DE EP	5394800 A 19922592 A 1099032 A	05/12/00 23/11/00 16/05/01
DE	29714251	U1	22/01/98	NONE		
DE	7408307	U	20/06/74	NONE		