

(No Model.)

2 Sheets—Sheet 1.

N. C. BASSETT.  
GEAR CASING FOR RAILWAY MOTORS.

No. 522,579.

Patented July 10, 1894.

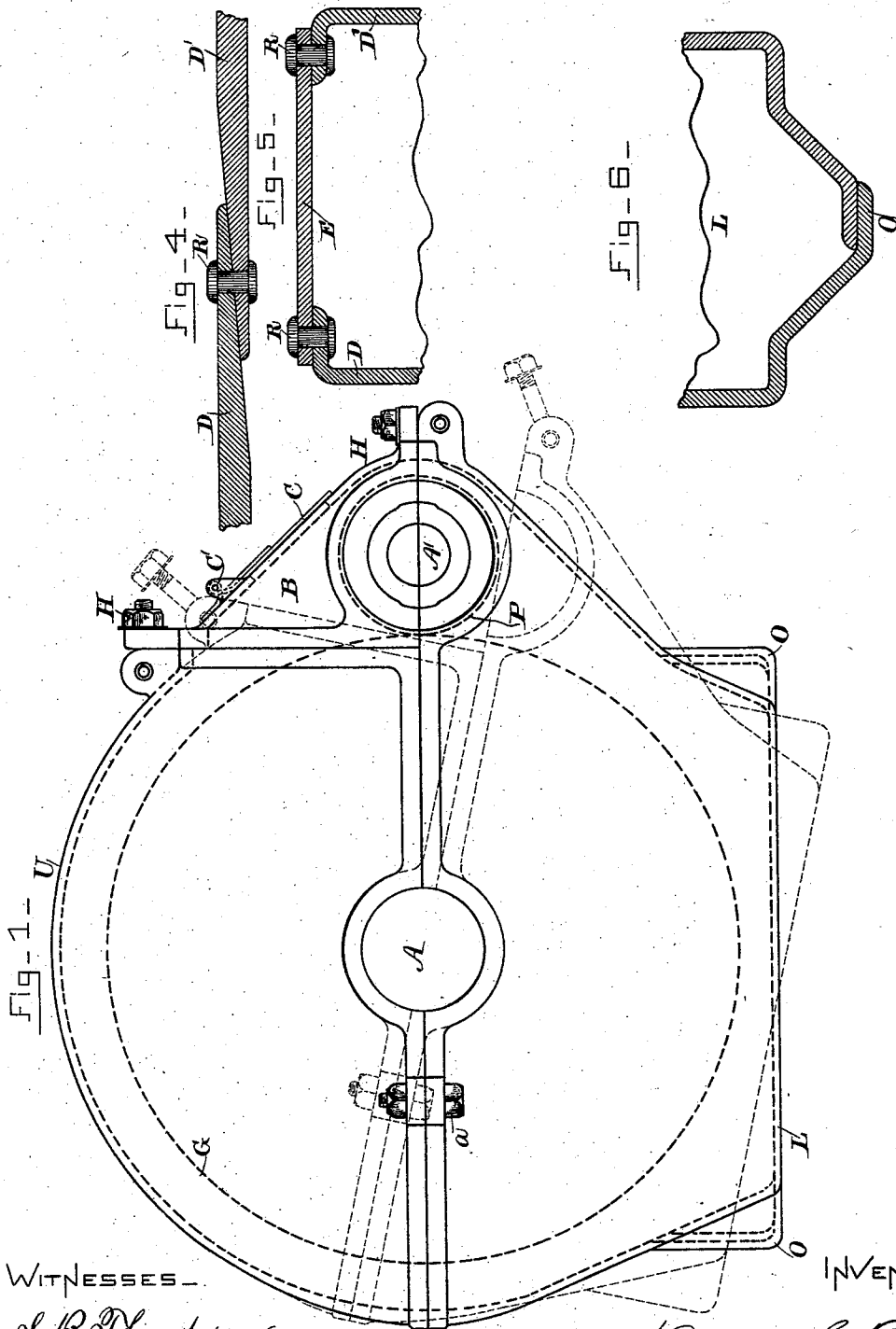

WITNESSES—

*S. B. Thompson.*  
*Attest*

INVENTOR—

*Norman C. Bassett*  
*by Bentley Knight*  
*Atty.*

N. C. BASSETT.  
GEAR CASING FOR RAILWAY MOTORS.

No. 522,579.

Patented July 10, 1894.

Fig-2-

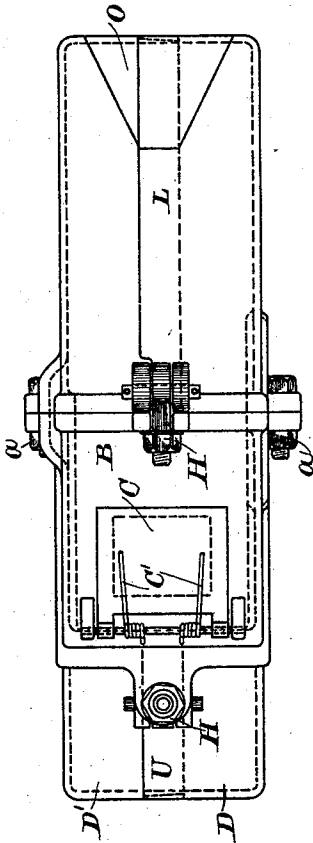
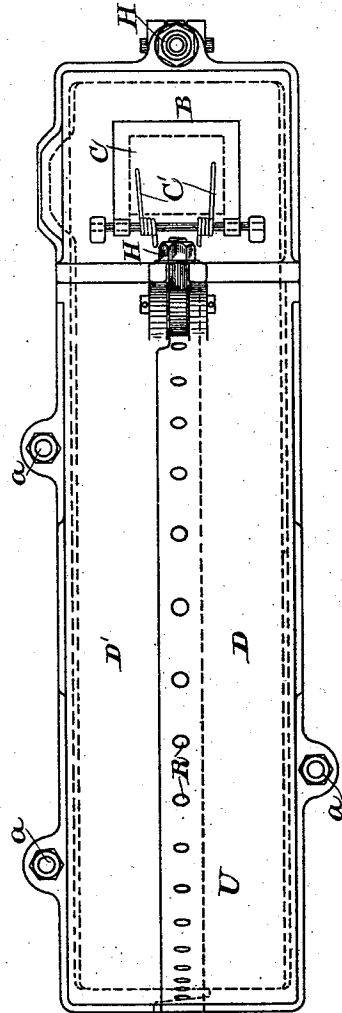

Fig-3-



WITNESSES-

*S. B. Thompson.*  
*Attorney*

INVENTOR-

*Norman C. Bassett*  
*by Bentley Knight*  
*Attys.*

# UNITED STATES PATENT OFFICE.

NORMAN C. BASSETT, OF LYNN, MASSACHUSETTS, ASSIGNOR TO THE THOMSON-HOUSTON ELECTRIC COMPANY, OF CONNECTICUT.

## GEAR-CASING FOR RAILWAY-MOTORS.

SPECIFICATION forming part of Letters Patent No. 522,579, dated July 10, 1894.

Application filed March 20, 1891. Serial No. 385,748. (No model.)

*To all whom it may concern:*

Be it known that I, NORMAN C. BASSETT, a citizen of the United States, residing at Lynn, in the county of Essex and State of Massachusetts, have invented a certain new and useful Improvement in Gear-Casings for Railway-Motors, of which the following is a specification.

My present invention relates to an improved gear case for holding oil and keeping out dust from the boxed in gearing. In designing it I have had in mind the peculiar needs present in electric motor trucks where the armature of the driving motor is geared to the axle by a single set of reduction gears, and the wear is such that it is of considerable importance to have a construction in which the pinion can be readily inspected, removed or replaced, without taking the gear case apart or disturbing the axle gear wheel.

My invention, however, is not necessarily limited to this particular application alone, nor to the number of gears inclosed in the casing.

In the accompanying drawings, Figure 1 is a side elevation of the gear case showing in dotted lines the position assumed when it is desired to remove the pinion. Figs. 2 and 3 are end and plan views of the same, and Figs. 4, 5, and 6 show sectional detail views of the mode of constructing the casing.

In Fig. 1 A is a gear shaft, which for illustration I will suppose to be the axle of an electrically driven car, and the dotted circle G represents the gear wheel on the axle. The driving shaft, or carrying out the above illustration, the armature shaft, is at A', and P represents the pinion meshing the gear wheel G. This gearing is inclosed in a casing consisting of two parts or halves, the upper U and the lower L, with their line of division passing through the shafts of the boxed-in gears so that the parts may be readily put together, and when in place the halves are fastened by bolts such as *a*. In the upper half of the case there is a comparatively small and independently removable section B located over and covering about one-half of the pinion, and held in place by lock nuts H, H. These nuts are hinged so that they may be turned over

between jaws on section B, and then by screwing up the nuts the section is readily secured in place. Should it now be desired to remove the pinion P this may be done by slackening the bolts H, removing the small section B, and then turning the gear case around the shaft A into the dotted line position, when the pinion can be withdrawn through the opening normally covered by B. In electric car service the pinions have to be renewed much more frequently than the large axle gears, and the capability of doing this readily as above is a great convenience. In the removable section B there is a hinged door C held closed by springs C' but permitting the ready inspection of the gears or introduction of oil.

For convenience of manufacture the upper and lower halves are not made of a single casting, but are each split into separate side pieces D, D', riveted together as shown at R in Fig. 3. This simplifies the manufacture, as each part may then be cast without a core in the foundry, and the halves L and U made of thinner metal than would be the case were each a single piece.

In Fig. 4 the side pieces are shown overlapping and fastened by a single set of rivets, while in Fig. 5 the side pieces have slight inwardly turned flanges and a separate metal strip E is riveted thereto by two lines of rivets as shown.

In the modern street car the motor and casing come low down, very near the surface of the street, and for the purpose of pushing aside stones or other obstructions in the path of the casing I make a plow O at its front lower corner, or preferably at each lower corner. The plow may be cast on the casing, and will be made of considerable rigidity so as to effectually clear away obstructions. A detail sectional view of the plow in shown in Fig. 6.

What I claim as new, and desire to secure by Letters Patent, is—

1. A gear casing pivoted on the gear wheel shaft, and having a small removable section boxing in the pinion, said section being joined to the casing on a line between the pinion and the gear, whereby the pinion can be removed axially, substantially as described.

2. A gear case pivoted on the gear wheel

shaft, and having a small removable section  
joined to the casing on lines passing through  
the gear and pinion shafts and between the  
pinion and gear, whereby when said section  
5 is removed, the rest of the casing can be swung  
away from the pinion to permit it to be re-  
moved from its shaft, substantially as set forth.  
3. A gear casing made in halves L, U, with  
the line of division passing through the boxed-  
10 in shafts, a section B in one half joined to the  
rest of the casing on the line of division, and  
covering one-half of the pinion, and lock nuts

H holding the section in place, but permitting  
its ready removal.

4. A gear casing made in halves with a small 15  
removable section over the pinion, and a  
spring-held door in said section affording ac-  
cess to the pinion.

In testimony whereof I have hereto set my  
hand this 16th day of March, 1891.

NORMAN C. BASSETT.

Witnesses:

JOHN W. GIBBONEY,  
BENJAMIN B. HULL.