

(19)



(11)

**EP 2 241 730 A1**

(12)

**EUROPEAN PATENT APPLICATION**

(43) Date of publication:  
**20.10.2010 Bulletin 2010/42**

(51) Int Cl.:  
**F01L 3/08 (2006.01)**

(21) Application number: **09005463.6**

(22) Date of filing: **17.04.2009**

(84) Designated Contracting States:  
**AT BE BG CH CY CZ DE DK EE ES FI FR GB GR  
 HR HU IE IS IT LI LT LU LV MC MK MT NL NO PL  
 PT RO SE SI SK TR**  
 Designated Extension States:  
**AL BA RS**

(72) Inventor: **Sakata, David**  
**Livonia**  
**MI 48152 (US)**

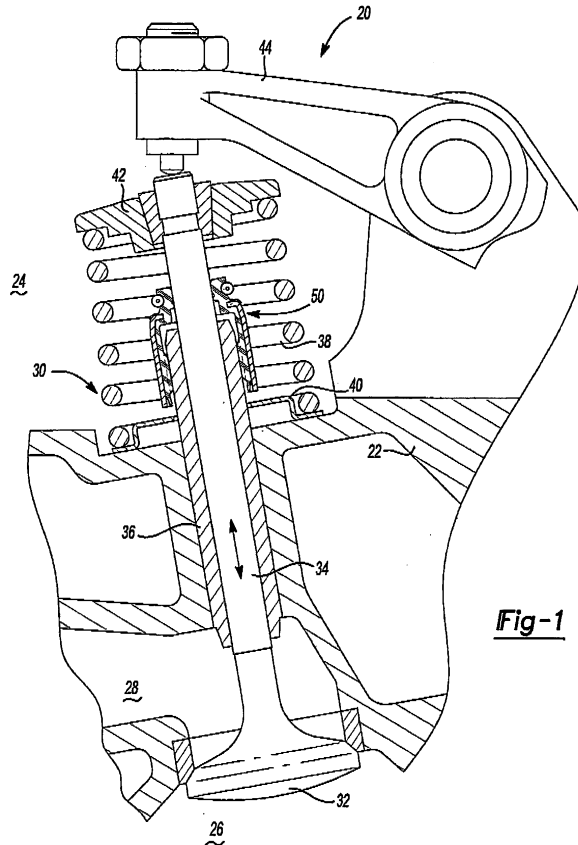
Remarks:  
 Amended claims in accordance with Rule 137(2)  
 EPC.

(71) Applicant: **Carl Freudenberg KG**  
**69469 Weinheim (DE)**

**(54) Valve stem seal with gas relief features**

(57) A valve stem seal can include an elastomeric component having a first portion for having a sealed engagement with a valve stem (34), and a pressure relief lip engaging a valve guide (36). The pressure relief lip can have a sealing configuration and a venting configuration. The venting configuration can allow excess exhaust gases to vent from a combustion chamber (26).

After the venting of excess exhaust gases, the pressure relief lip can close to the sealing configuration to prevent oil from entering the combustion chamber (26). The elastomeric body or the valve guide can include a pressure relief channel. The elastomeric body can also include a bumper engaging the valve guide (36). The pressure relief channel can be disposed in the bumper.



**Fig-1**

**EP 2 241 730 A1**

## Description

### FIELD

**[0001]** The present disclosure relates to valve stem seals, and, in particular, to valve stem seals for use in internal combustion engines.

### BACKGROUND

**[0002]** The statements in this section merely provide background information related to the present disclosure and may not constitute prior art.

**[0003]** Internal combustion engines are known to employ valve stem seals to regulate oil to the valve guide and minimize oil from entering a combustion chamber. However, the weakness of the current art is that pressure from the combustion chamber and an exhaust port of an engine can affect the function of primary sealing lips of valve stem seals. Gas lips, which provide an additional seal, have been applied, but pressure acting on such a gas lip can cause the orientation of a primary sealing lip against a valve stem to change and result in improper function. Accordingly, it would be desirable to provide a valve stem seal that can relieve pressure while continuing to prevent excessive oil from entering the combustion chamber.

### SUMMARY

**[0004]** In one form, the present disclosure provides a valve stem seal for an internal combustion engine. The valve stem seal can include an annular elastomeric body adapted to be disposed around a valve stem and a valve guide for the engine. The elastomeric body can have a first portion adapted to have a sealed engagement with the valve stem and a second portion adapted to extend around the valve guide. The elastomeric body can also include a connecting portion extending radially outwardly from the first portion to the second portion and a pressure relief lip extending from the second portion. The pressure relief lip can have a sealing configuration and a venting configuration. The sealing configuration can be adapted to close a passageway in fluid communication with a combustion chamber of the engine to a lubrication chamber of the engine. The venting configuration can be adapted to open the passageway to the lubrication chamber. The pressure relief lip can be operable to open to the venting configuration at a predetermined pressure within the passageway and the combustion chamber to allow excess exhaust gases to vent from the passageway and the combustion chamber. Furthermore, the pressure relief lip can be operable to close to the sealing configuration after the venting of the excess exhaust gases to prevent fluid from the lubrication chamber from entering the passageway and the combustion chamber.

**[0005]** In another form, the present disclosure provides a valve stem seal assembly for an internal combustion

engine. The engine can include a housing separating a lubrication chamber and a combustion chamber, a valve guide fixed in the housing, and a valve stem extending through the valve guide and housing between the lubrication chamber and the combustion chamber. The valve stem seal assembly can include an annular rigid body and an annular elastomeric body both adapted to be disposed around the valve guide and the valve stem. The elastomeric body can include a first portion adapted to have a sealed engagement with the valve stem and a second portion adapted to extend around the valve guide. The elastomeric body can also include a connecting portion extending radially outwardly from the first portion to the second portion and a pressure relief lip extending from the second portion. The pressure relief lip can have a sealing configuration and a venting configuration. The sealing configuration can be adapted to close a passageway in fluid communication with the combustion chamber to the lubrication chamber. The venting configuration can be adapted to open the passageway to the lubrication chamber. The pressure relief lip can be operable to open to the venting configuration at a predetermined pressure within the passageway and the combustion chamber to allow excess exhaust gases to vent from the passageway and the combustion chamber. Furthermore, the pressure relief lip can be operable to close to the sealing configuration after the venting of the excess exhaust gases to prevent fluid from the lubrication chamber from entering the passageway and the combustion chamber.

**[0006]** In another form, the present disclosure provides another valve stem seal assembly for an internal combustion engine. The valve stem seal assembly can include an annular elastomeric body and an annular rigid body. The elastomeric body can be adapted to be disposed around a valve guide and a valve stem of the engine. The elastomeric body can include a pressure relief lip and the elastomeric body or alternately the valve guide can include a pressure relief channel. The elastomeric body can also include a bumper engaging the valve guide. The pressure relief channel can be disposed in the bumper.

**[0007]** Further areas of applicability will become apparent from the description provided herein. It should be understood that the description and specific examples are intended for purposes of illustration only and are not intended to limit the scope of the present disclosure.

### DRAWINGS

**[0008]** The drawings described herein are for illustration purposes only and are not intended to limit the scope of the present disclosure in any way.

Figure 1 is a cross-sectional view of a portion of an internal combustion engine including a valve stem seal assembly according to the principles of the present disclosure;

Figure 2A is a cross-sectional view of a seal component of a valve stem seal assembly according to the principles of the present disclosure;

Figure 2B is a cross-sectional view of the seal component of Figure 2A along line 2B shown in Figure 2A;

Figure 3A is a cross-sectional view of the valve stem seal assembly of Figure 1 including a pressure relief lip in a sealing configuration according to the principles of the present disclosure;

Figure 3B is a cross-sectional view of the valve stem seal assembly of Figure 3A including the pressure relief lip in a venting configuration according to the principles of the present disclosure;

Figure 4 is a cross-sectional view of another valve stem seal assembly according to the principles of the present disclosure;

Figure 5 is a cross-sectional view of another valve stem seal assembly according to the principles of the present disclosure;

Figure 6A is a cross-sectional view of another valve stem seal assembly according to the principles of the present disclosure;

Figure 6B is a cross-sectional view of a rigid component of the valve stem seal assembly of Figure 6A;

Figure 6C is a cross-sectional view of the rigid component of Figure 6B along the line 6C shown in Figure 6B;

Figure 7 is a cross-sectional view of another valve stem seal assembly according to the principles of the present disclosure;

Figure 8 is another cross-sectional view of a valve stem seal assembly according to the principles of the present disclosure;

Figure 9 is a cross-sectional view of a portion of another internal combustion engine including another valve stem seal assembly according to the principles of the present disclosure;

Figure 10 is a cross-sectional view of the valve stem seal assembly of Figure 9;

Figure 11 is a cross-sectional view of another valve stem seal assembly according to the principles of the present disclosure;

Figure 12 is a cross-sectional view of another valve

stem seal assembly according to the principles of the present disclosure;

Figure 13 is a cross-sectional view of another valve stem seal assembly according to the principles of the present disclosure;

Figure 14 is a cross-sectional view of another valve stem seal assembly according to the principles of the present disclosure;

Figure 15 is a cross-sectional view of another valve stem seal assembly according to the principles of the present disclosure;

Figure 16 is a cross-sectional view of another valve stem seal assembly according to the principles of the present disclosure;

Figure 17 is a cross-sectional view of another valve stem seal assembly according to the principles of the present disclosure;

Figure 18 is a cross-sectional view of another valve stem seal assembly according to the principles of the present disclosure;

Figure 19 is a cross-sectional view of another valve stem seal assembly according to the principles of the present disclosure;

Figure 20 is a cross-sectional view of another valve stem seal assembly according to the principles of the present disclosure;

Figure 21 is a cross-sectional view of another valve stem seal assembly according to the principles of the present disclosure;

Figure 22 is a cross-sectional view of another valve stem seal assembly according to the principles of the present disclosure;

Figure 23 is a cross-sectional view of another valve stem seal assembly according to the principles of the present disclosure;

Figure 24 is a cross-sectional view of another valve stem seal assembly according to the principles of the present disclosure;

Figure 25 is a cross-sectional view of another valve stem seal assembly according to the principles of the present disclosure;

Figure 26 is a cross-sectional view of another valve stem seal assembly according to the principles of the present disclosure; and

Figure 27 is a cross-sectional view of another valve stem seal assembly according to the principles of the present disclosure.

#### DETAILED DESCRIPTION

**[0009]** The following description is merely exemplary in nature and is not intended to limit the present disclosure, application, or uses. It should be understood that throughout the drawings, corresponding reference numerals indicate like or corresponding parts and features. For example, like elements may be referred to by the reference numerals 15, 115, and 215. Additionally, as used herein, the terms "axial" or "axially" refer to a direction substantially parallel to an axis of a shaft or cylindrical body according to the principles of the present disclosure. Furthermore, as used herein, the terms "radial" and "radially" refer to directions substantially perpendicular to an axis of a shaft or cylindrical body according to the principles of the present disclosure.

**[0010]** According to the principles of the present disclosure, a valve stem seal can include an elastomeric component having a first portion for having a sealed engagement with a valve stem, a second portion for engaging a valve guide, and a pressure relief lip extending from the second portion. The pressure relief lip can have a sealing configuration and a venting configuration. The venting configuration can allow excess exhaust gases to vent from a combustion chamber. After the venting of excess exhaust gases, the pressure relief lip can close to the sealing configuration to prevent oil and/or other fluids from entering the combustion chamber.

**[0011]** Referring to Figure 1, a portion of an engine 20 is shown. According to the principles of the present disclosure, engine 20 can be an internal combustion engine and can have a variety of forms and configurations, including but not limited to an overhead valve configuration and overhead camshaft configuration. Engine 20 can have a variety of components including a housing 22. Housing 22 can define a lubrication or oil chamber 24 and a combustion chamber 26. Housing 22 can further define an inlet or exhaust chamber 28 for combustion chamber 26. It should be understood that further reference to inlet chamber 28 herein as "inlet" should also be considered as equally pertaining to the exhaust chamber as well. Engine 20 can further include a valve assembly 30 disposed between oil chamber 24 and combustion chamber 26. As the general function and operation of engine 20 and the components thereof are well known to those of ordinary skill in the art, they will not be further described herein.

**[0012]** Valve assembly 30 can have a variety of components. Valve assembly 30 can include a valve head 32 disposed within combustion chamber 26. Valve head 32 can be connected to a valve stem 34, which can be disposed within a valve guide 36. Valve stem 34 and valve guide 36 can extend through housing 22 between oil chamber 24 and combustion chamber 26. Valve as-

sembly 30 can further include a valve spring 38 within oil chamber 24. Valve spring 38 can be disposed between a valve spring seat 40 and a valve spring retainer 42. Valve spring seat 40 can be coupled to housing 22, and valve spring retainer can be coupled to valve stem 34. Valve assembly 30 can further include an actuation mechanism 44 disposed within oil chamber 24. Actuation mechanism 44 can vary according to the form of engine 20. Additionally, valve assembly 30 can include a valve stem seal assembly 50 disposed around valve stem 34 and valve guide 36 within oil chamber 24.

**[0013]** Valve assembly 30 can be selectively operable to control fluid communication between combustion chamber 26 and inlet chamber 28. In particular, valve head 32 can be positioned to close combustion chamber 26 to fluid communication with inlet chamber 28 or to open combustion chamber 26 to fluid communication with inlet chamber 28. The position of valve head 32 can correspond to the position of valve stem 34. Valve guide 36 can be coupled to housing 22, and valve stem 34 can be operable to move in an axial direction relative to valve guide 36. Valve spring 38 can bias valve stem 34 and valve head 32 into a home position. As shown in Figure 1, the home position can correspond to valve head 32 closing combustion chamber 26 to fluid communication with inlet chamber 28. Furthermore, actuation mechanism 44 can be selectively operated to move valve stem 34 and valve head 32 from the home position and thereby open combustion chamber 26 to fluid communication with inlet chamber 28. During operation of valve assembly 30, valve stem seal assembly 50 can provide a seal around valve stem 34 and valve guide 36 and can regulate oil and/or other fluids from oil chamber 24 from entering combustion chamber 26.

**[0014]** During operation of engine 20, excess exhaust gases can build up in combustion chamber 26 or back flow from chamber 28. These excess exhaust gases can travel between valve guide 36 and valve stem 34 and can exert pressure on valve stem seal assembly 50. According to the principles of the present disclosure, valve stem seal assembly 50 can include venting features so that, at a predetermined pressure, excess exhaust gases can be vented. Such venting can prevent a decrease in performance of valve stem seal assembly 50 and/or failure of valve stem seal assembly 50 such as blow-off. The venting features of valve stem seal assembly 50 are described in further detail below.

**[0015]** Referring to Figures 2A and 2B, valve stem seal assembly 50 can include a seal component 52. Seal component 52 can be a single, unitary body having a generally annular shape. Seal component 52 can include a first or top portion 54. Top portion 54 can be configured to be disposed around and have a sealed engagement with valve stem 34. For example, top portion 54 can have an inside surface 55 defining sealing feature 56 and support features 57 for directly engaging valve stem 34 (Figures 3A and 3B). In particular, four support features 57 can be disposed around inside surface 55. Additionally, an

intermediate or connecting portion 58 can extend radially outwardly from top portion 54.

**[0016]** Seal component 52 can also include a second or bottom portion 60. Bottom portion 60 can extend from connecting portion 58 in an axial direction away from top portion 54. Bottom portion 60 can be configured to extend around and have a selectively sealed engagement with valve guide 36. To provide for the selectively sealed engagement with valve guide 36, bottom portion 60 can have an inside surface 62 defining at least one protrusion 63 and channel 64. For example, a plurality of protrusions 63 and channels 64 can be provided around the inside surface 62, as shown in the Figures. Protrusions 63 can be sized to engage with valve guide 36 and can provide for a press fit between bottom portion 60 and valve guide 36. According to the principles of the present disclosure, channels 64 can provide for gas communication between bottom portion 60 and valve guide 36 and, thus, can form part of a passageway in gas communication with combustion chamber 26, as described in further detail below.

**[0017]** Bottom portion 60 can also have a pressure relief lip 68 extending therefrom. Pressure relief lip 68 can extend from bottom portion 60 and contact valve guide 36 (Figure 3A). As described in further detail below, pressure relief lip 68 can have a selectively sealed engagement with valve guide 36. Bottom portion 60 can also have an outside surface 70. Additionally, seal component 52 can be made of a variety of elastomeric materials including but not limited to fluoroelastomers, polyacrylics, and natural rubber.

**[0018]** Valve stem seal assembly 50 can also include a rigid component 72 (Figures 3A and 3B). Rigid component 72 can have a generally annular shape and can extend around seal component 52. Rigid component 72 can include an inside surface 74 configured to engage with outside surface 70 of bottom portion 60 of seal component 52 and a radially inwardly extending flange portion 75 engaging intermediate portion 58. Rigid component 72 can be made of a variety of relatively rigid materials.

**[0019]** Additionally, valve stem seal assembly 50 can include a spring 80. Spring 80 can be disposed around top portion 54 of seal component 52. Spring 80 can exert an inward biasing force on top portion 54 to enhance the sealed engagement between seal component 52 and valve stem 34.

**[0020]** Referring to Figures 3A and 3B, valve stem seal assembly 50 can be disposed around valve stem 34 and valve guide 36. As noted above, top portion 54 of seal component 52 can have a sealed engagement with valve stem 34, and bottom portion 60 can engage valve guide 36. Furthermore, rigid component 72 can be disposed around seal component 52 and can help maintain the position of seal component 52.

**[0021]** Pressure relief lip 68 can have a sealing configuration, as shown in Figure 3A. In the sealing configuration, pressure relief lip 68 can engage valve guide 36. The sealing configuration of pressure relief lip 68 can

allow valve stem seal assembly 50 to prevent fluid communication between oil chamber 24 and combustion chamber 26.

**[0022]** Pressure relief lip 68 can also have a venting configuration, as shown in Figure 3B. As noted above, excess exhaust gases from combustion chamber 26 or back flow from chamber 28 can exert pressure on valve stem seal assembly 50. At a predetermined pressure in combustion chamber 26 or chamber 28 and the passageway, excess exhaust gases can cause pressure relief lip 68 to open to the venting configuration. With pressure relief lip 68 in the venting configuration, excess exhaust gases can vent from combustion chamber 26 through the passageway including channels 64 and to oil chamber 24. When the pressure in combustion chamber 26 and the passageway is below the predetermined pressure, pressure relief lip 68 can return to the sealing configuration and, thus, prevent oil or other fluids from oil chamber 24 from entering combustion chamber 26. Thus, according to the principles of the present disclosure, valve stem seal assembly 50 can vent excess exhaust gases from combustion chamber 26 while maintaining a sealed engagement around valve stem 34 and thus preventing oil and/or other fluids from oil chamber 24 from entering combustion chamber 26.

**[0023]** Referring to Figures 4 to 20, additional embodiments of valve stem seal assemblies according to the principles of the present disclosure are shown. It will be understood that various embodiments of the present disclosure can incorporate similar components and features, and the descriptions of the components and features herein are not particular to a single embodiment and can apply to components and features in various embodiments.

**[0024]** Referring to Figure 4, a valve stem seal assembly 150 is shown. Valve stem seal assembly 150 can include a seal component 152 which includes a gas lip 190. Gas lip 190 can provide an additional seal between seal component 152 and a valve stem 134. Gas lip 190 can also help direct excess exhaust gases toward a pressure relief lip 168. Otherwise, valve stem seal assembly 150 and seal component 152 can be substantially similar to valve stem seal assembly 50 and seal component 52 discussed above.

**[0025]** Referring to Figure 5, a valve stem seal assembly 250 can include a seal component 252 having an inverted top portion 254. Seal component 252 can further include a connecting portion 258 extending radially outwardly from top portion 254 and a bottom portion 260 extending axially from connecting portion 258. Due to the inverted configuration of top portion 254, bottom portion 260 can extend around top portion 254. Otherwise, bottom portion 260 can be substantially similar to bottom portion 60 discussed above. The configuration of top portion 254 can help guide excess exhaust gases toward a pressure relief lip 268. Furthermore, due to the configuration of top portion 254, pressure exerted on top portion 254 can enhance the sealed engagement of top portion

254 with a valve stem 234.

**[0026]** Referring to Figures 6A-6C, a valve stem seal assembly 350 can include a seal component 352 and a rigid component 372. Rigid component 372 can be configured to engage valve guide 336 between seal component 352 and valve guide 336. In particular, rigid component 372 can have a press fit with valve guide 336. Furthermore, rigid component 372 can define an inner surface 374 and an outer surface 376. Inner surface 374 can include protrusions 377 and channels 378. According to the principles of the present disclosure, channels 378 can provide for fluid communication between rigid component 372 and valve guide 336 and can function substantially similarly to channels 64 of seal component 52 discussed above. Additionally, seal component 352 can be disposed around rigid component 372 and can have a pressure relief lip 368 in contact with valve guide 336. Pressure relief lip 368 can be substantially similar to pressure relief lip 68 discussed above.

**[0027]** Referring to Figure 7, a valve stem seal assembly 450 can include a seal component 452 and a rigid component 472. Seal and rigid components 452, 472 can include all of the features of seal and rigid components 352, 372 discussed above. Additionally, seal component 452 can include an oil lip 492. Oil lip 492 can extend from a connecting portion 458 axially away from a bottom portion 460. Oil lip 492 can define a pool or lubrication fluid trap around valve stem 434 for oil or other lubricant to gather and be available to lubricate valve stem 434 during operation.

**[0028]** Referring to Figure 8, a valve stem seal assembly 550 according to the principles of the present disclosure which does not include venting features is shown. Valve stem seal assembly 550 can include a seal component 552 having an inverted top portion 554. The configuration of top portion 554 can enhance the sealed engagement between top portion 554 and a valve stem 534 such as is discussed above with regard to seal component 252 and top portion 254.

**[0029]** Referring to Figure 9, an alternate configuration of an engine 620 is shown. Engine 620 can have many components that are substantially similar to engine 20 discussed above. However, engine 620 can include a valve spring seat 640 which can extend upward and form a part of a valve stem seal assembly 650.

**[0030]** Referring to Figure 10, a valve stem seal assembly 650 can include a seal component 652 substantially similar to seal component 52 discussed above. Valve stem seal assembly 650 can also include valve spring seat 640. Valve spring seat 640 can be disposed around and can engage with seal component 652. Valve spring seat 640 can help to maintain the position of seal component 652 similar to rigid component 72 discussed above. Furthermore, valve spring seat 640 can include apertures 694 proximate a pressure relief lip 668. Apertures 694 can provide for venting of excess exhaust gases.

**[0031]** Referring to Figure 11, a valve stem seal as-

sembly 750 can include a seal component 752 and a valve spring seat 740. Seal component 752 can be substantially similar to seal component 152 discussed above, and a valve spring seat 740 can be substantially similar to valve spring seat 640 discussed above.

**[0032]** Referring to Figure 12, a valve stem seal assembly 850 can include a seal component 852 and a valve spring seat 840. Seal component 852 can be substantially similar to seal component 252 discussed above, and valve spring seat 840 can be substantially similar to valve spring seat 640 discussed above.

**[0033]** Referring to Figure 13, a valve stem seal assembly 950 can include a valve guide 936, a seal component 952, and a rigid component 972. Seal component 952 can be substantially similar to seal component 152 discussed above. However, seal component 952 includes a bottom portion 960 which does not have any protrusions or channels formed therein. Rigid component 972 can be substantially similar to rigid component 72 discussed above. Valve guide 936 can include at least one channel 998 formed therein. For example, as shown in Figure 13, valve guide 936 can have a plurality of channels 998. With seal component 952 disposed around valve guide 936, channels 998 can provide for gas communication between bottom portion 960 and valve guide 936 and, thus, can form part of a passageway in gas communication with a combustion chamber as described above.

**[0034]** Referring to Figure 14, the valve stem seal assembly 1050 can include a valve guide 1036, a seal component 1052, and a rigid component 1072. Seal component 1052 can be substantially similar to seal component 252 discussed above. However, bottom portion 1060 of seal component 1052 does not include protrusions or channels formed therein. Rigid component 1072 can be substantially similar to rigid component 272 discussed above. Furthermore, valve guide 1036 can be substantially similar to valve guide 936.

**[0035]** Referring to Figure 15, a valve stem seal assembly 1150 can include a valve guide 1136, a seal component 1152, and a valve spring seat 1140. Seal component 1152 can be substantially similar to seal component 952 discussed above. Valve spring seat 1140 can be substantially similar to valve spring seat 640 discussed above. Furthermore, valve guide 1136 can be substantially similar to valve guide 936 discussed above.

**[0036]** Referring to Figure 16, a valve stem seal assembly 1250 can include a valve guide 1236, a seal component 1252, and a valve spring seat 1240. Seal component 1252 can be substantially similar to seal component 1052 discussed above. Valve spring seat 1240 can be substantially similar to valve spring seat 640 discussed above. Furthermore, valve guide 1236 can be substantially similar to valve guide 936 discussed above.

**[0037]** Referring to Figure 17, a valve stem seal assembly 1350 can include a valve guide 1336, a seal component 1352, and a rigid component 1372. Seal component 1352 can be substantially similar to seal component

952 discussed above. However, valve guide 1336 includes retention groove 1354 for reducing the potential for seal pop off, by providing a ridge that the seal forms where the rubber is not compressed at the groove to improve retention. Rigid component 1372 can be substantially similar to rigid component 972 discussed above. Valve guide 1336 can include at least one channel 1398 formed therein. For example, as shown in Figure 17, valve guide 1336 can have a plurality of channels 1398. With seal component 1352 disposed around valve guide 1336, channels 1398 can provide for gas communication between bottom portion 1360 and valve guide 1336 and, thus, can form part of a passageway in gas communication with a combustion chamber as described above.

**[0038]** Referring to Figure 18, the valve stem seal assembly 1050 of Fig. 14 is shown with a retention groove 1454 provided in the valve guide 1036.

**[0039]** Referring to Figure 19, a valve stem seal assembly 1550 can include a valve guide 1536, a seal component 1552, and a rigid component 1572. The rigid component 1572 includes a radially outwardly stepped portion 1502 and supporting a radially inwardly extending distal end portion 1504 as the pressure relief lip in contact with the surface of the valve guide. The seal component 1552 includes a bottom portion 1560 that has a radially outwardly stepped portion 1506 corresponding to the outwardly stepped portion 1502 of the rigid component 1572. The outwardly step portion 1502 provides a valve spring pilot to assist centering of the valve spring, and creates a larger radial space for optional vent lip configurations for increase tuning of the opening pressure of the lip.

**[0040]** As shown in Figure 20, the rigid component 1572 with a outwardly stepped portion 1502 stepped portion and a supported radially inwardly extending distal end portion 1504 contacting the valve guide 1536 is shown incorporated with a seal component 1650 having an inverted top portion 1654. The outwardly step portion 1502 provides a valve spring pilot to assist centering of the valve spring, and creates a larger radial space for optional vent lip configurations for increase tuning of the opening pressure of the lip. The cavity created radially inward by the step portion 1502 allows oil to pool above the vent lip which assists sealing any vacuum pressure that may exist outside the vent lip. The pool of oil acts as a barrier to the vacuum pressure but will release the oil when a positive pressure in the cavity occurs, thereby allowing the vent lip to release positive pressure while sealing against a possible vacuum pressure.

**[0041]** Referring to Figure 21, valve stem seal assembly 1750 can include a seal component 1752. Seal component 1752 can be a single, unitary body having a generally annular shape. Seal component 1752 can include a first or top portion 1754. Top portion 1754 can be configured to be disposed around and have a sealed engagement with valve stem 34. For example, top portion 1754 can have a sealing feature 1756 and a gas lip 1757 each engaging the valve stem 34. Additionally, an intermediate or connecting portion 1758 can extend radially

outward from top portion 1754.

**[0042]** Seal component 1752 can also include a second or bottom portion 1760. Bottom portion 1760 can extend from connecting portion 1758 in an axial direction away from top portion 1754. Bottom portion 1760 can be configured to extend around and have sealed engagement with valve guide 36. Valve stem seal assembly 1750 can also include a rigid component 1772. Rigid component 1772 can have a generally annular shape and can extend around seal component 1752. Rigid component 1772 can include an inside surface 1774 configured to engage with an outside surface 1770 of bottom portion 1760 of seal component 1752 and a radially inwardly extending flange portion 1775 engaging intermediate portion 1758. Rigid component 1772 can be made of a variety of relatively rigid materials.

**[0043]** Valve stem seal assembly 1750 can include a spring 1780. Spring 1780 can be disposed around top portion 1754 of seal component 1752. Spring 1780 can exert an inward biasing against top portion 1754 to enhance sealed engagement between seal component 1752 and valve stem 34. The seal component 1752 can further include an axially extending pressure relief lip 1782 extending from the top portion 1754 and engaging an end face of the valve guide 36. A bumper 1784 can extend axially from either the top portion 1754 or the connecting portion 1758 of the seal component 1752 and engages an end of the valve guide 36. A pressure relief channel 1786 is formed radially through the bumper 1784. The valve guide 36 can further include an axially extending pressure relief channel 1790 in an outer surface thereof. Excessive back pressure or gasses are directed at the pressure relief lip 1782 which will open and allow pressure/gasses to exit out along the channel 1786 and channel 1790 thereby allowing the primary sealing lip 1756 to function properly. Referring to Figure 22, valve stem seal assembly 1850 can include a seal component 1852. Seal component 1852 can be a single, unitary body having a generally annular shape. Seal component 1852 can include a first or top portion 1854. Top portion 1854 can be configured to be disposed around and have a sealed engagement with valve stem 34. For example, top portion 1854 can have a sealing feature 1856 and a gas lip 1857 each engaging the valve stem 34. Additionally, an intermediate or connecting portion 1858 can extend radially outward from top portion 1854.

**[0044]** Valve stem seal assembly 1850 can also include a rigid component 1872. Rigid component 1872 can have a generally annular shape and can extend around valve guide 36. Rigid component 1872 can include an inside surface 1874 configured to engage with an outside surface of the valve guide 36 and a radially inwardly extending flange portion 1875 engaging connecting portion 1858. Rigid component 1872 can be made of a variety of relatively rigid materials.

**[0045]** Valve stem seal assembly 1850 can include a spring 1880. Spring 1880 can be disposed around top portion 1854 of seal component 1852. Spring 1880 can

exert an inward biasing against top portion 1854 to enhance sealed engagement between seal component 1852 and valve stem 34. The seal component 1852 can further include an axially extending pressure relief lip 1882 extending from the top portion 1854 and engaging an end face of the valve guide. A bumper 1884 can extend axially from either the top portion 1854 or the connecting portion 1858 of the seal component 1852 and engages an end of the valve guide 36. The valve guide 36 can further include an axially extending pressure relief channel 1890 in an outer surface thereof that extends beyond a lower edge of the rigid component 1872. The pressure relief channel 1890 can also engage with a radially inwardly extending channel 1892 provided on an end face of the valve guide 36. The channel 1892 extends radially inward beyond a radially inner edge of a shoulder 1876 of the rigid component 1872. The shoulder 1876 is disposed against an end face of the valve guide 36. Excessive back pressure or gasses are directed at the pressure relief lip 1882 which will open and allow pressure/gasses to exit out along the channel 1892 and channel 1890 thereby allowing the primary sealing lip 1856 to function properly.

**[0046]** Referring to Figure 23, valve stem seal assembly 1950 can include a seal component 1952. Seal component 1952 can be a single, unitary body having a generally annular shape. Seal component 1952 can include a first or top portion 1954. Top portion 1954 can be configured to be disposed around and have a sealed engagement with valve stem 34. For example, top portion 1954 can have a sealing feature 1956 and a gas lip 1957 each engaging the valve stem 34. Additionally, an intermediate or connecting portion 1958 can extend radially outward from top portion 1954.

**[0047]** Seal component 1952 can also include a second or bottom portion 1960. Bottom portion 1960 can extend from connecting portion 1958 in an axial direction away from top portion 1954. Bottom portion 1960 can be configured to extend around and have sealed engagement with valve guide 36. Valve stem seal assembly 1950 can also include a rigid component 1972. Rigid component 1972 can have a generally annular shape and can extend around seal component 1952. Rigid component 1972 can include an inside surface 1974 configured to engage with an outside surface 1970 of bottom portion 1960 of seal component 1952 and a radially inwardly extending flange portion 1975 engaging intermediate portion 1958. Rigid component 1972 can be made of a variety of relatively rigid materials.

**[0048]** Valve stem seal assembly 1950 can include a spring 1980. Spring 1980 can be disposed around top portion 1954 of seal component 1952. Spring 1980 can exert an inward biasing against top portion 1954 to enhance sealed engagement between seal component 1952 and valve stem 34. The seal component 1952 can further include an axially extending pressure relief lip 1982 extending from the top portion 1954 and engaging an end face of the valve guide 36. A bumper 1984 can

extend axially from either the top portion 1954 or the connecting portion 1958 of the seal component 1952 and engages an end of the valve guide 36. A pressure relief channel 1986 is formed radially through the bumper 1984. The bottom portion 1960 of the seal component 1952 can further include an axially extending pressure relief channel 1992 in an inner surface thereof. Excessive back pressure or gasses are directed at the pressure relief lip 1982 which will open and allow pressure/gasses to exit out along the channel 1986 and channel 1992 thereby allowing the primary sealing lip 1956 to function properly.

**[0049]** Referring to Figure 24, valve stem seal assembly 2050 can include a seal component 2052. Seal component 2052 can be a single, unitary body having a generally annular shape. Seal component 2052 can include a first or top portion 2054. Top portion 2054 can be configured to be disposed around and have a sealed engagement with valve stem 34. For example, top portion 2054 can have a sealing feature 2056 and a gas lip 2057 each engaging the valve stem 34. Additionally, an intermediate or connecting portion 2058 can extend radially outward from top portion 2054.

**[0050]** Valve stem seal assembly 2050 can also include a rigid component 2072. Rigid component 2072 can have a generally annular shape and can extend around valve guide 36. Rigid component 2072 can include an inwardly protruding portion 2074 configured to engage with an outside surface of the valve guide 36 and a radially inwardly extending flange portion 2075 engaging connecting portion 2058. Rigid component 2072 can be made of a variety of relatively rigid materials.

**[0051]** Valve stem seal assembly 2050 can include a spring 2080. Spring 2080 can be disposed around top portion 2054 of seal component 2052. Spring 2080 can exert an inward biasing against top portion 2054 to enhance sealed engagement between seal component 2052 and valve stem 34. The seal component 2052 can further include an axially extending pressure relief lip 2082 extending from the top portion 2054 and engaging an end face of the valve guide 36. A bumper 2084 can extend axially from either the top portion 2054 or the connecting portion 2058 of the seal component 2052 and engages an end of the valve guide 36. A pressure relief channel 2086 is formed radially through the bumper 2084. Excessive back pressure or gasses are directed at the pressure relief lip 2082 which will open and allow pressure/gasses to exit out along the channel 2086 and through a gap 2094 between the valve guide 36 and the rigid component 2072 thereby allowing the primary sealing lip to function properly.

Referring to Figure 25, valve stem seal assembly 2150 can include a seal component 2152. Seal component 2152 can be a single, unitary body having a generally annular shape. Seal component 2152 can include a first or top portion 2154. Top portion 2154 can be configured to be disposed around and have a sealed engagement with valve stem 34. For example, top portion 2154 can

have a sealing feature 2156 and a gas lip 2157 each engaging the valve stem 34. Additionally, an intermediate or connecting portion 2158 can extend radially outward from top portion 2154.

**[0052]** Valve stem seal assembly 2150 can also include a rigid component 2172. Rigid component 2172 can have a generally annular shape and can extend around valve guide 36. Rigid component 2172 can include an inwardly protruding portion 2174 configured to engage with an outside surface of the valve guide 36 and a radially inwardly extending flange portion 2175 engaging connecting portion 2158. Rigid component 2172 can be made of a variety of relatively rigid materials.

**[0053]** Valve stem seal assembly 2150 can include a spring 2180. Spring 2180 can be disposed around top portion 2154 of seal component 2152. Spring 2180 can exert an inward biasing against top portion 2154 to enhance sealed engagement between seal component 2152 and valve stem 34. The seal component 2152 can further include an axially extending pressure relief lip 2182 extending from the top portion 2154 and engaging an end face of the valve guide 36. A bumper 2184 can extend axially from either the top portion 2154 or the connecting portion 2158 of the seal component 2156 and engages an end of the valve guide 36. The valve stem 36 can include a radially extending pressure relief channel 2190 in an end surface thereof. The pressure relief channel 2190 extends beyond inner and outer edges of bumper 2184. Excessive back pressure or gasses are directed at the pressure relief lip 2182 which will open and allow pressure/gasses to exit out along the channel 2190 and through a gap between the valve guide 36 and the rigid component 2172 thereby allowing the primary sealing lip 2156 to function properly.

**[0054]** Referring to Figure 26, valve stem seal assembly 2250 can include a seal component 2252. Seal component 2252 can be a single, unitary body having a generally annular shape. Seal component 2252 can include a first or top portion 2254. Top portion 2254 can be configured to be disposed around and have a sealed engagement with valve stem 34. For example, top portion 2254 can have a sealing feature 2256 and a gas lip 2257 each engaging the valve stem 34. Additionally, an intermediate or connecting portion 2258 can extend radially outward from top portion 2254.

**[0055]** Valve stem seal assembly 2250 can also include a rigid component 2272. Rigid component 2272 can have a generally annular shape and can extend around valve guide. Rigid component 2272 can tightly engage valve guide 36 and can include a venting aperture 2290 and a radially inwardly extending flange portion 2275 engaging connecting portion 2258. Rigid component 2272 can be made of a variety of relatively rigid materials.

**[0056]** Valve stem seal assembly 2250 can include a spring 2280. Spring 2280 can be disposed around top portion 2254 of seal component 2252. Spring 2280 can exert an inward biasing against top portion 2254 to en-

hance sealed engagement between seal component 2252 and valve stem 34. The seal component 2252 can further include an axially extending pressure relief lip 2282 extending from the top portion 2254 and engaging an end face of the valve guide 36. A bumper 2284 can extend axially from either the top portion 2254 or the connecting portion 2258 of the seal component 2252 and engages an end of the valve guide 36. A pressure relief channel 2286 is formed radially through the bumper 2284. Excessive back pressure or gasses are directed at the pressure relief lip 2282 which will open and allow pressure/gasses to exit out along the channel 2286 and venting aperture 2290 thereby allowing the primary sealing lip 2256 to function properly.

**[0057]** Referring to Figure 27 valve stem seal assembly 2350 can include a seal component 2352. Seal component 2352 can be a single, unitary body having a generally annular shape. Seal component 2352 can include a first or top portion 2354. Top portion 2354 can be configured to be disposed around and have a sealed engagement with valve stem 34. For example, top portion 2354 can have a sealing feature 2356 and a gas lip 2357 each engaging the valve stem 34. Additionally, an intermediate or connecting portion 2358 can extend radially outward from top portion 2354.

**[0058]** Valve stem seal assembly 2350 can also include a rigid component 2372. Rigid component 2372 can have a generally annular shape and can extend around valve guide 36. Rigid component 2372 can tightly engage with an outside surface of valve guide 36 and can include a venting aperture 2390 and a radially inwardly extending flange portion 2375 engaging connecting portion 2358. Rigid component 2372 can be made of a variety of relatively rigid materials.

**[0059]** Valve stem seal assembly 2350 can include a spring 2380. Spring 2380 can be disposed around top portion 2354 of seal component 2352. Spring 2380 can exert an inward biasing against top portion 2354 to enhance sealed engagement between seal component 2352 and valve stem 34. The seal component 2352 can further include an axially extending pressure relief lip 2382 extending from the sealed portion 2354 and engaging an end face of the valve guide 36. A bumper 2384 can extend axially from either the top portion 2354 or the connecting portion 2358 of the seal component 2352 and engages an end of the valve guide 36. The valve stem 36 includes a radially extending pressure relief channel 2392 in an end surface thereof. The pressure relief channel 2392 extends radially beyond inner and outer edges of the bumper 2384. Excessive back pressure or gasses are directed at the pressure relief lip 2382 which will open and allow pressure/gasses to exit out along the channel 2392 and through venting aperture 2390 thereby allowing the primary sealing lip 2356 to function properly.

**[0060]** The present disclosure can vary in many ways. A valve stem seal assembly or a seal component according to the principles of the present disclosure can be used in a variety of applications including, but not limited to,

providing a fluid seal between a lubrication or oil chamber and a combustion chamber of an internal combustion engine. Furthermore, a seal component of a valve stem seal assembly according to the present disclosure can have a variety of configurations. It is to be appreciated that a seal component and a valve stem seal assembly according to the present disclosure are not limited to the embodiments disclosed herein. As such, a valve stem seal assembly according to the principles of the present disclosure can include a variety of combinations to the components and features disclosed herein. Additionally, other components of a valve stem seal assembly can also vary, and a valve stem seal assembly can also include additional components. For example, valve stem seal assembly can include further retaining members to help maintain the position of seal components. Additionally, the components of valve stem seal assemblies can be made of a variety of materials.

## Claims

1. A valve stem seal assembly for an internal combustion engine, the engine including a housing separating a lubrication chamber and a combustion chamber, the valve stem seal assembly comprising:

a valve guide fixed in the housing and extending between the lubrication chamber and the combustion chamber, said valve guide including a pressure relief channel in an outer surface thereof;

a valve stem extending through said valve guide between the lubrication chamber and the combustion chamber; and

an annular elastomeric body adapted to be disposed around said valve stem and said valve guide, said elastomeric body including a first portion adapted to have a sealed engagement with the valve stem, a second portion adapted to extend around the valve guide, a connecting portion extending radially outwardly from said first portion to said second portion,

and a pressure relief lip extending from said connecting portion, said pressure relief lip having a sealing configuration and a venting configuration, said sealing configuration adapted to close a passageway in fluid communication with a combustion chamber of the engine to a lubrication chamber of the engine, said venting configuration adapted to open the passageway to the lubrication chamber;

wherein said pressure relief lip is operable to open to said venting configuration at a predetermined pressure within the passageway and the combustion chamber to allow excess exhaust gasses to vent from the passageway and the combustion chamber, and said pressure re-

lief lip is operable to close to said sealing configuration after the venting of the excess exhaust gases to prevent fluid from the lubrication chamber from entering the passageway and the combustion chamber.

2. The valve stem seal assembly according to claim 1, further comprising a bumper extending axially from said connecting portion and engaging an end portion of said valve guide.

The valve stem seal assembly according to claim 2, wherein said bumper includes a pressure relief channel in an end surface thereof.

3. A valve stem seal assembly for an internal combustion engine, the engine including a housing separating a lubrication chamber and a combustion chamber, the valve stem seal assembly comprising:

a valve guide fixed in the housing and extending between the lubrication chamber and the combustion chamber, said valve guide including a pressure relief channel in a surface thereof;

a valve stem extending through said valve guide between the lubrication chamber and the combustion chamber; and

an annular elastomeric body adapted to be disposed around said valve stem, said elastomeric body including a first portion adapted to have a sealed engagement with the valve stem and a pressure relief lip extending from said first portion, said pressure relief lip having a sealing configuration and a venting configuration, said sealing configuration adapted to close a passageway in fluid communication with a combustion chamber of the engine to a lubrication chamber of the engine, said venting configuration adapted to open the passageway to the lubrication chamber;

wherein said pressure relief lip is operable to open to said venting configuration at a predetermined pressure within the passageway and the combustion chamber to allow excess exhaust gasses to vent from the passageway and the combustion chamber, and said pressure relief lip is operable to close to said sealing configuration after the venting of the excess exhaust gases to prevent fluid from the lubrication chamber from entering the passageway and the combustion chamber.

4. The valve stem seal assembly according to claim 4, further comprising an annular rigid body attached to said annular elastomeric body, said annular rigid body extending around said valve guide and including a shoulder portion disposed against an end of said valve guide.

5. The valve stem seal assembly according to claim 5, wherein said pressure relief channel in said valve guide extends radially inward beyond an inner edge of said shoulder portion of said annular rigid body and axially beyond an end of said annular rigid body.

6. The valve stem seal assembly according to claim 4, further comprising a bumper extending from said annular elastomeric body and engaging an end of said valve guide, said pressure relief channel extending radially inward of an inner edge of said bumper and radially outward of an outer edge of said bumper.

7. A valve stem seal assembly for an internal combustion engine, the engine including a housing separating a lubrication chamber and a combustion chamber, the valve stem seal assembly comprising:

a valve guide fixed in the housing and extending between the lubrication chamber and the combustion chamber;

a valve stem extending through said valve guide between the lubrication chamber and the combustion chamber; and

an annular elastomeric body adapted to be disposed around said valve stem and said valve guide, said elastomeric body including a first portion adapted to have a sealed engagement with the valve stem, a second portion adapted to extend around the valve guide, a connecting portion extending radially outwardly from said first portion to said second portion,

and a pressure relief lip extending from said connecting portion, said pressure relief lip having a sealing configuration and a venting configuration, said sealing configuration adapted to close a passageway in fluid communication with a combustion chamber of the engine to a lubrication chamber of the engine, said venting configuration adapted to open the passageway to the lubrication chamber, a bumper extending axially from said connecting portion and engaging an end portion of said valve guide, wherein said bumper includes a pressure relief channel in an end surface thereof;

wherein said pressure relief lip is operable to open to said venting configuration at a predetermined pressure within the passageway and the combustion chamber to allow excess exhaust gasses to vent from the passageway and the combustion chamber, and said pressure relief lip is operable to close to said sealing configuration after the venting of the excess exhaust gases to prevent fluid from the lubrication chamber from entering the passageway and the combustion chamber.

8. The valve stem seal assembly according to claim 8,

wherein said second portion of said elastomeric body includes a pressure relief channel formed therein.

9. A valve stem seal assembly for an internal combustion engine, the engine including a housing separating a lubrication chamber and a combustion chamber, the valve stem seal assembly comprising:

a valve guide fixed in the housing and extending between the lubrication chamber and the combustion chamber, said valve guide including a pressure relief channel in a surface thereof; a valve stem extending through said valve guide between the lubrication chamber and the combustion chamber, and

an annular elastomeric body adapted to be disposed around said valve stem, said elastomeric body including a first portion adapted to have a sealed engagement with the valve stem and a pressure relief lip extending from said first portion, said pressure relief lip having a sealing configuration and a venting configuration, said sealing configuration adapted to close a passageway in fluid communication with a combustion chamber of the engine to a lubrication chamber of the engine, said venting configuration adapted to open the passageway to the lubrication chamber, a bumper extending axially from said connecting portion and engaging an end portion of said valve guide;

wherein said pressure relief lip is operable to open to said venting configuration at a predetermined pressure within the passageway and the combustion chamber to allow excess exhaust gasses to vent from the passageway and the combustion chamber, and said pressure relief lip is operable to close to said sealing configuration after the venting of the excess exhaust gases to prevent fluid from the lubrication chamber from entering the passageway and the combustion chamber.

10. A valve stem seal assembly for an internal combustion engine, the engine including a housing separating a lubrication chamber and a combustion chamber, the valve stem seal assembly comprising:

a valve guide fixed in the housing and extending between the lubrication chamber and the combustion chamber;

a valve stem extending through said valve guide between the lubrication chamber and the combustion chamber; and

an annular elastomeric body adapted to be disposed around said valve stem, said elastomeric body including a first portion adapted to have a sealed engagement with the valve stem and a pressure relief lip extending from said first por-

tion, said pressure relief lip having a sealing configuration and a venting configuration, said sealing configuration adapted to close a passageway in fluid communication with a combustion chamber of the engine to a lubrication chamber of the engine, said venting configuration adapted to open the passageway to the lubrication chamber, a bumper extending axially from said connecting portion and engaging an end portion of said valve guide, wherein said bumper includes a pressure relief channel in an end surface thereof;

wherein said pressure relief lip is operable to open to said venting configuration at a predetermined pressure within the passageway and the combustion chamber to allow excess exhaust gasses to vent from the passageway and the combustion chamber, and said pressure relief lip is operable to close to said sealing configuration after the venting of the excess exhaust gases to prevent fluid from the lubrication chamber from entering the passageway and the combustion chamber.

11. The valve stem seal assembly according to claim 11, further comprising an annular rigid body attached to said annular elastomeric body, said annular rigid body including a venting aperture therein.
12. The valve stem seal assembly according to claim 11, further comprising an annular rigid body attached to said annular elastomeric body, said annular rigid body defining a vent passage between said annular rigid body and said valve guide.
13. A valve stem seal assembly for an internal combustion engine, the engine including a housing separating a lubrication chamber and a combustion chamber, the valve stem seal assembly comprising:

a valve guide fixed in the housing and extending between the lubrication chamber and the combustion chamber, said valve guide including a pressure relief channel in a surface thereof;

a valve stem extending through said valve guide between the lubrication chamber and the combustion chamber; and

an annular elastomeric body adapted to be disposed around said valve stem, said elastomeric body including a seal portion adapted to have a sealed engagement with the valve stem and a pressure relief lip extending from said seal portion, said pressure relief lip having a sealing configuration and a venting configuration, said sealing configuration adapted to close a passageway in fluid communication with a combustion chamber of the engine to a lubrication chamber of the engine, said venting configuration adapt-

ed to open the passageway to the lubrication chamber, a bumper extending from said annular elastomeric body and engaging an end of said valve guide, said pressure relief channel extending radially inward of an inner edge of said bumper and radially outward of an outer edge of said bumper;

wherein said pressure relief lip is operable to open to said venting configuration at a predetermined pressure within the passageway and the combustion chamber to allow excess exhaust gasses to vent from the passageway and the combustion chamber, and said pressure relief lip is operable to close to said sealing configuration after the venting of the excess exhaust gases to prevent fluid from the lubrication chamber from entering the passageway and the combustion chamber.

14. The valve stem seal assembly according to claim 14, further comprising an annular rigid body attached to said annular elastomeric body, said annular rigid body extending around said valve guide and defining an air passage between said valve guide and said annular rigid body.
15. The valve stem seal assembly according to claim 14, further comprising an annular rigid body attached to said annular elastomeric body, said annular rigid body including a venting aperture therein.

#### Amended claims in accordance with Rule 137(2) EPC.

1. A valve stem seal assembly (50; 150; 250; ... 2350) for an internal combustion engine, the engine including a housing (22) separating a lubrication chamber (24) and a combustion chamber (26), the valve stem seal assembly comprising:

a valve guide (36; 336; ... 1536) fixed in the housing and extending between the lubrication chamber and the combustion chamber, said valve guide including a pressure relief channel (1786; 1890; 1986; 2086; 2286) in a surface thereof;

a valve stem (34; 134; ... 534) extending through said valve guide between the lubrication chamber and the combustion chamber; and

an annular elastomeric body (52; 152; 252; ... 2352) adapted to be disposed around said valve stem, said elastomeric body including a first portion (54; 1754; ...; 2254) adapted to have a sealed engagement with the valve stem and a pressure relief lip (68; 168; 268; 368; 668) extending from said first portion, said pressure relief lip having a sealing configuration and a vent-

ing configuration, said sealing configuration adapted to close a passageway in fluid communication with a combustion chamber of the engine to a lubrication chamber of the engine, said venting configuration adapted to open the passageway to the lubrication chamber;

**characterized in that**

said pressure relief lip (68; 168; 268; 368; 668) is operable to open to said venting configuration at a predetermined pressure within the passageway and the combustion chamber (26) to allow excess exhaust gasses to vent from the passageway and the combustion chamber (26), and said pressure relief lip (68; ...) is operable to close to said sealing configuration after the venting of the excess exhaust gases to prevent fluid from the lubrication chamber (24) from entering the passageway and the combustion chamber (26).

**2.** The valve stem seal assembly (50; 150; 250; ... 2350) according to claim 1, wherein said pressure relief channel (1786; 1890; 1986; 2086; 2286) is provided in an outer surface of said valve guide (36; 336; ...; 1536).

**3.** The valve stem seal assembly (50; 150; 250; ... 2350) according to claim 1 or 2, wherein said annular elastomeric body (52; 152; ... 2352) is adapted to be disposed around said valve stem (34; 134; ... 534) and said valve guide (36; 336; ... 1536).

**4.** The valve stem seal assembly (50; 150; 250; ... 2350) according to anyone of the preceding claims 1 to 3, wherein said elastomeric body includes a second position (60; 260; ... 1960) adapted to extend around the valve guide (36 ...; 1536), a connecting portion (258; ... 2358) extending radially outwardly from said first portion to said second portion, and said pressure relief lip (68; 168; ...; 668) extending from said first position (54; ... 2254).

**5.** The valve stem seal assembly according to claim 4, further comprising a bumper (1784; ...; 2384) extending axially from said connecting portion (250; ...; 2350) and engaging an end portion of said valve guide (36; ...; 1536)

**6.** The valve stem seal assembly according to claim 5, wherein said pressure relief channel (1786; ... 2286) in said valve guide extends radially inward beyond an inner edge of said shoulder portion (36; ... 1536) of said annular rigid body (72; ...) and axially beyond an end of said annular rigid body (72; ...).

**7.** The valve stem seal assembly according to claim 4, further comprising a bumper (1784; ... 2384) extending from said annular elastomeric body (52; ...;

2352) and engaging an end of said valve guide (36; ...; 1536), said pressure relief channel (1786; ... 2288) extending radially inward of an inner edge of said bumper (1784; ...; 2384) and radially outward of an outer edge of said bumper (1784; ... 2384).

**8.** The valve stem seal assembly (50; 150; 250; ... 2350) according to claim 5, wherein said bumper (1784;... 2384) includes a pressure relief channel (1788; ... 2286) in an end surface thereof.

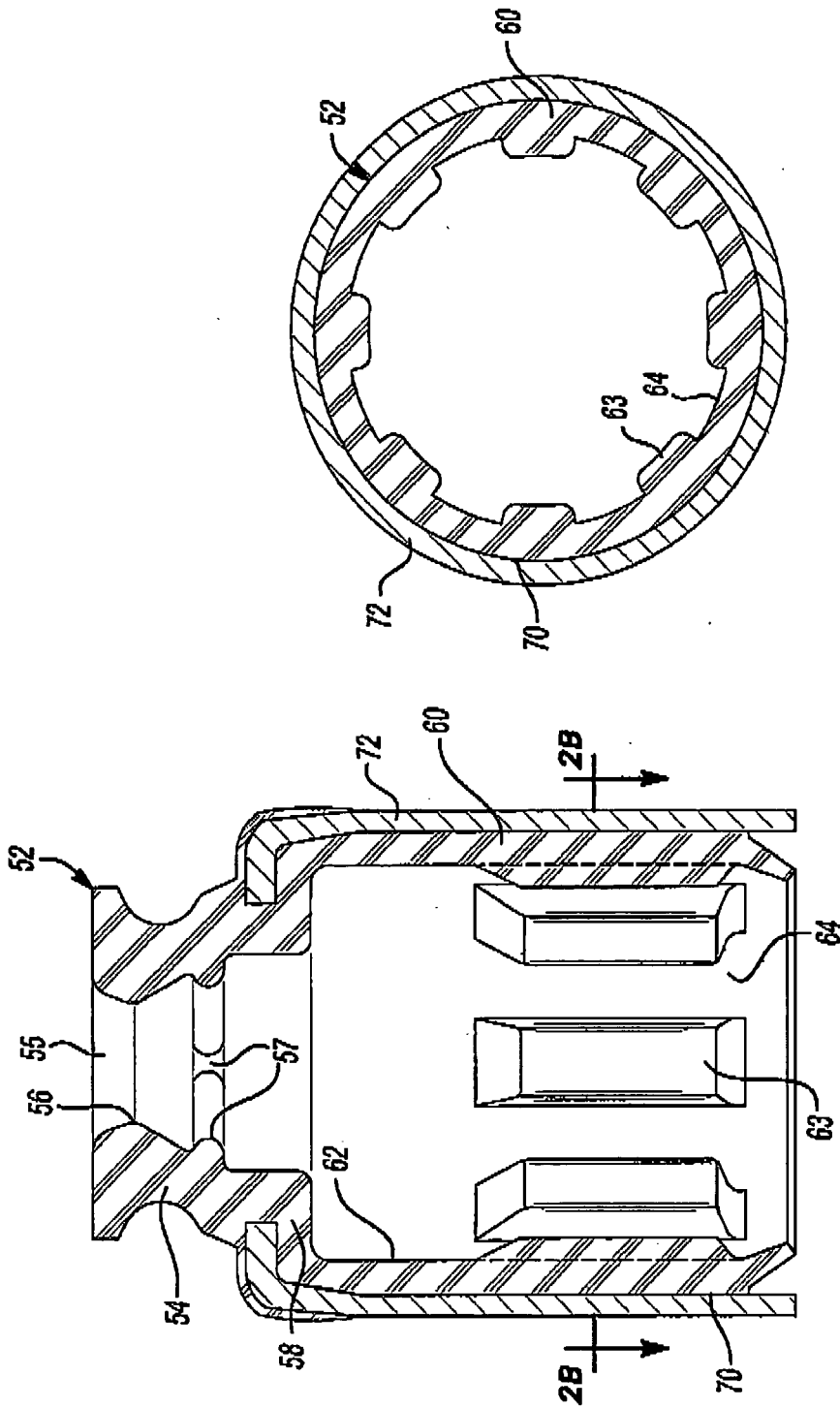
**9.** The valve stem seal assembly according to claim 8, wherein said second portion (60; ... 1960) of said elastomeric body (52; ... 2352) includes a pressure relief channel (1786; ... 2286) formed therein.

**10.** The valve stem seal assembly according to any of the preceding claims, comprising an annular rigid body (72; ...) attached to said annular elastomeric body (52; ... 2352), said annular rigid body (72; ...) including a venting aperture therein.

**11.** The valve stem seal assembly according to claim 10, further comprising an annular rigid body (72; ...) attached to said annular elastomeric body (52; ...; 2352), said annular rigid body defining a vent passage between said annular rigid body (72; ...) and said valve guide (36; ...; 1536).

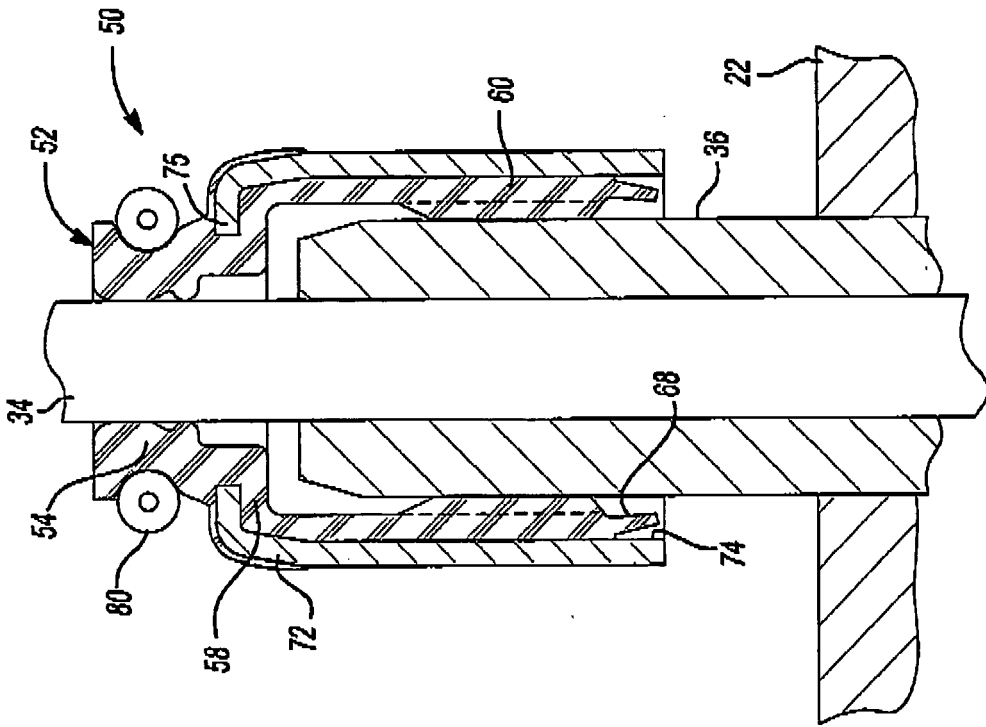
**12.** The valve stem seal assembly according to any of the preceding claims, wherein said first portion (54; ... 2254) is a seal portion.



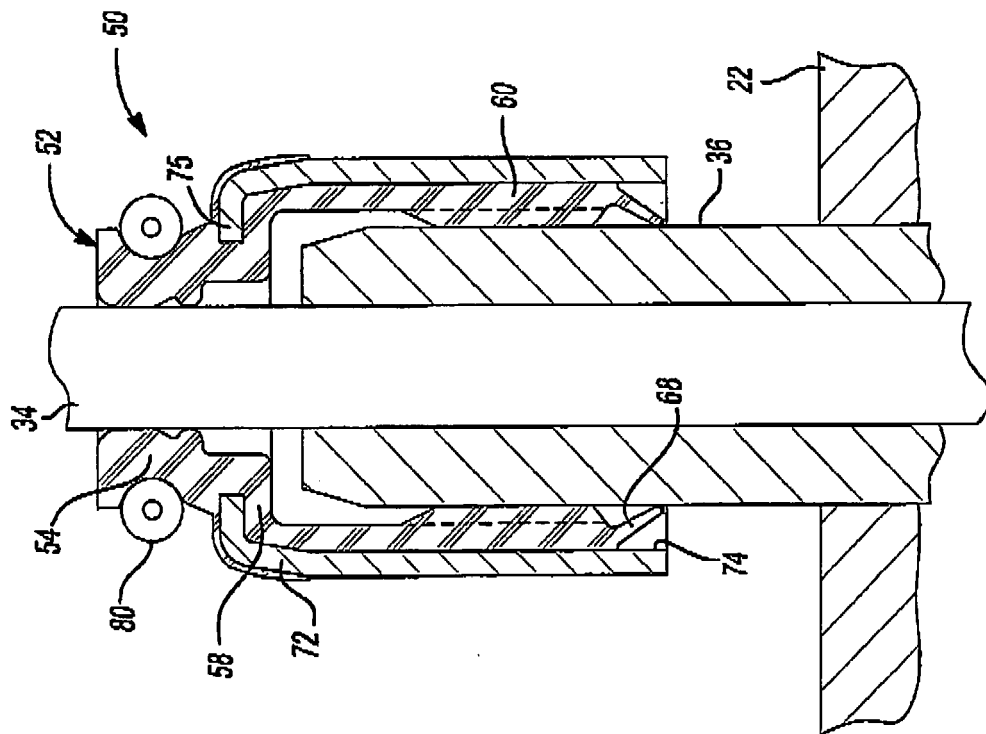


**Fig-2B**

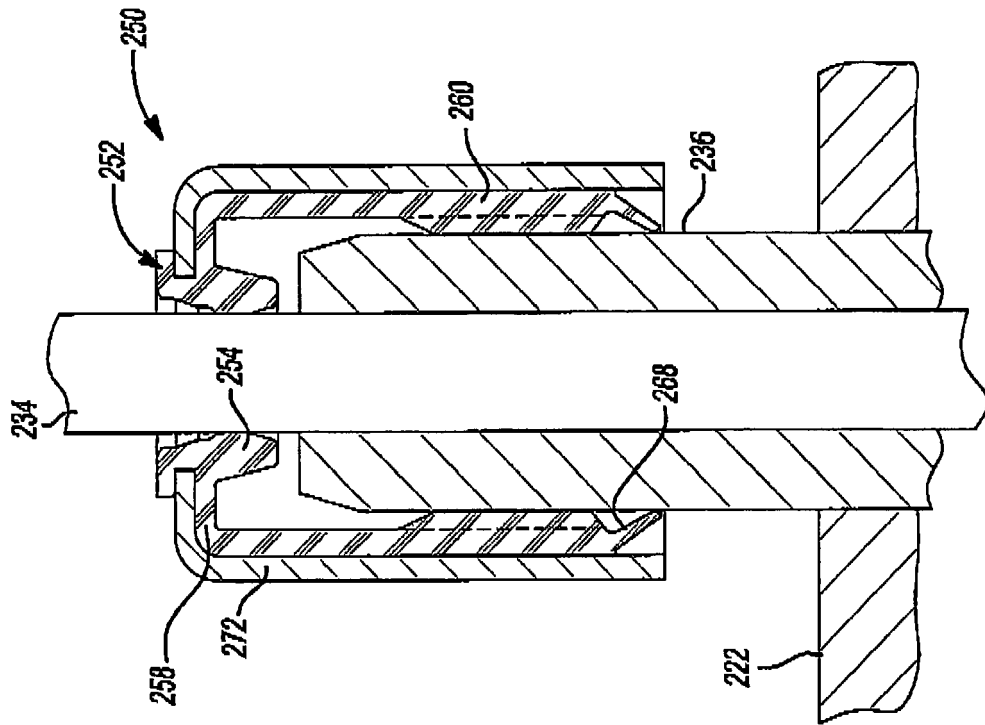
**Fig-2A**



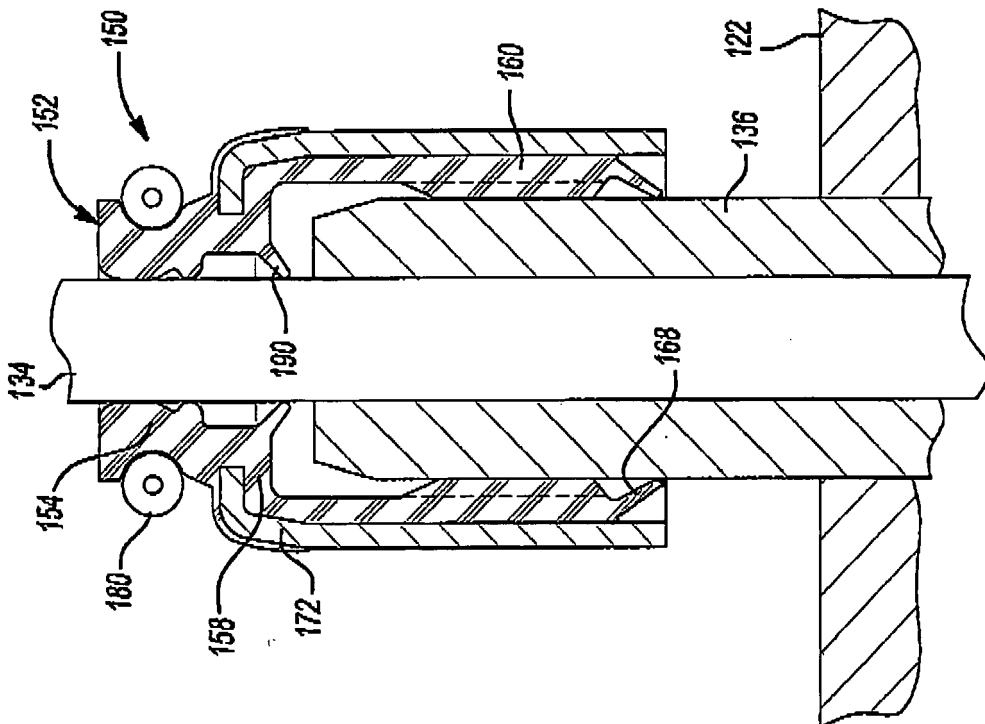
**Fig-3B**



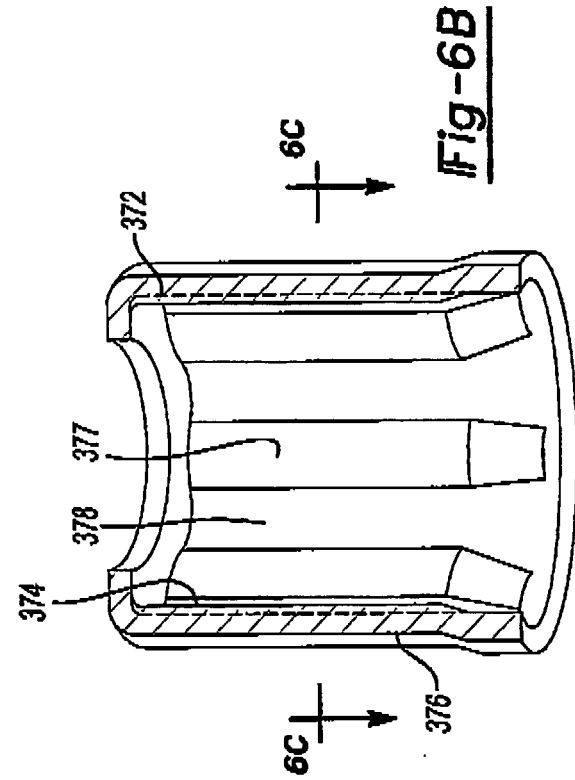
**Fig-3A**



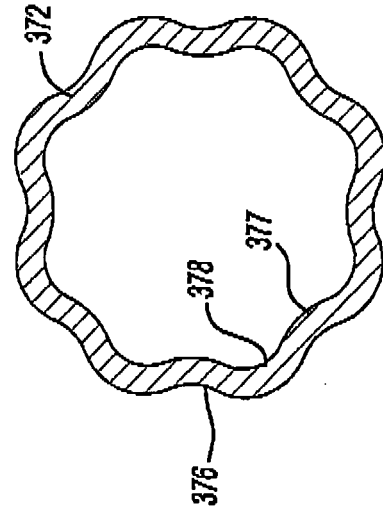
**Fig-5**



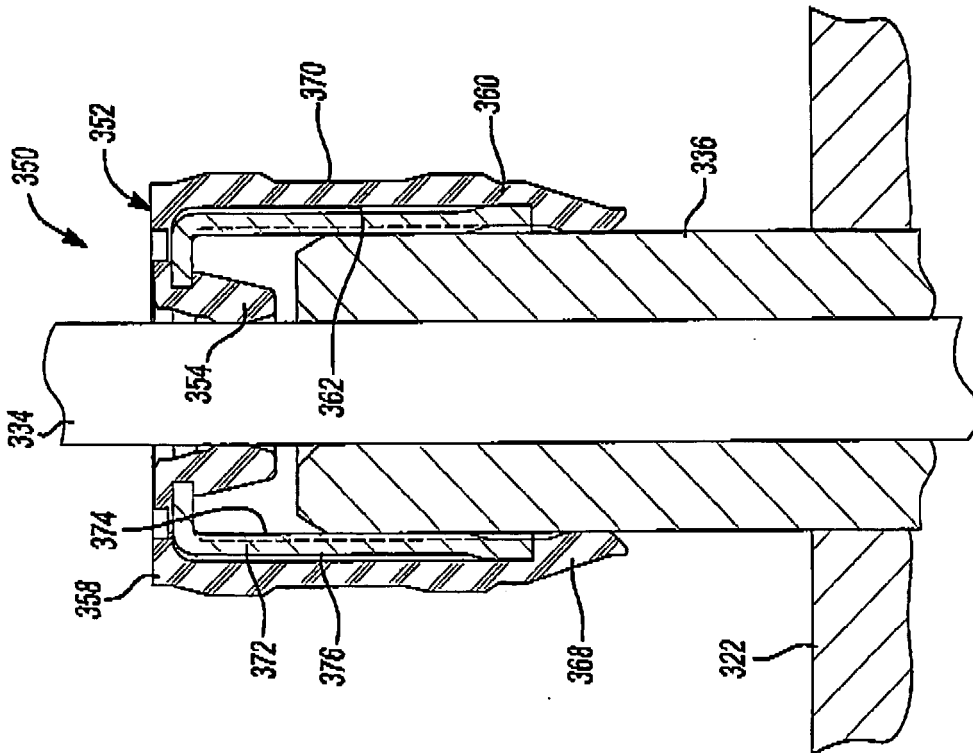
**Fig-4**



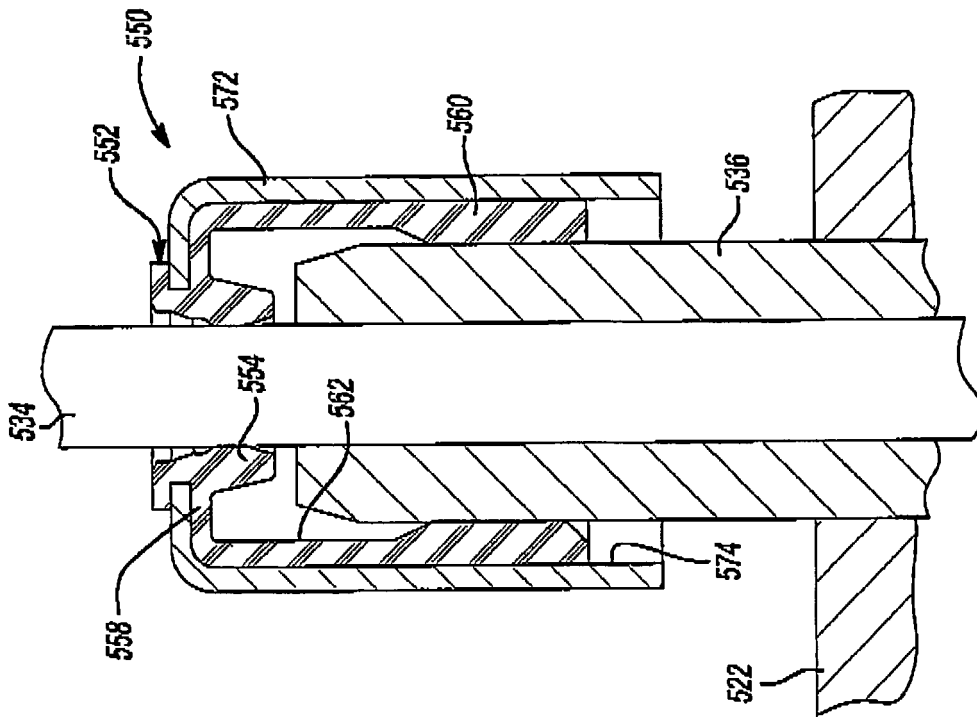
**Fig-6B**



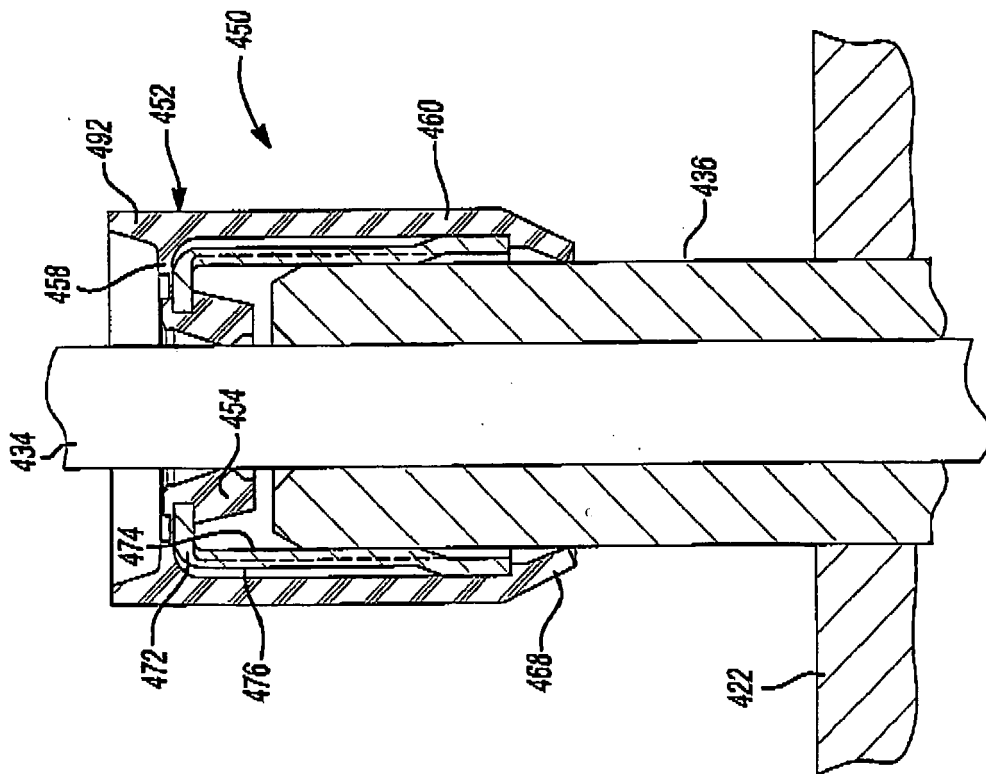
**Fig-6C**



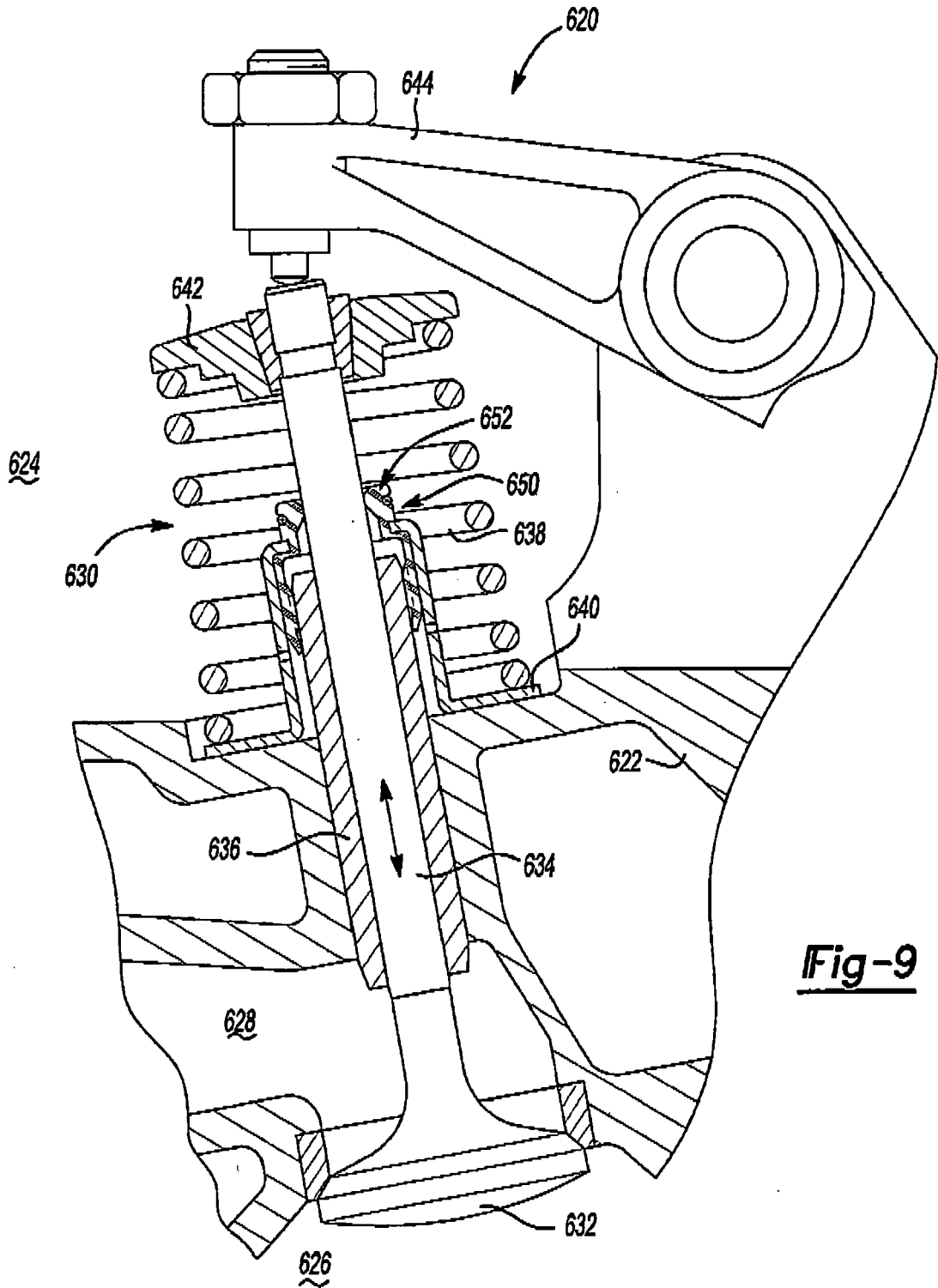
**Fig-6A**



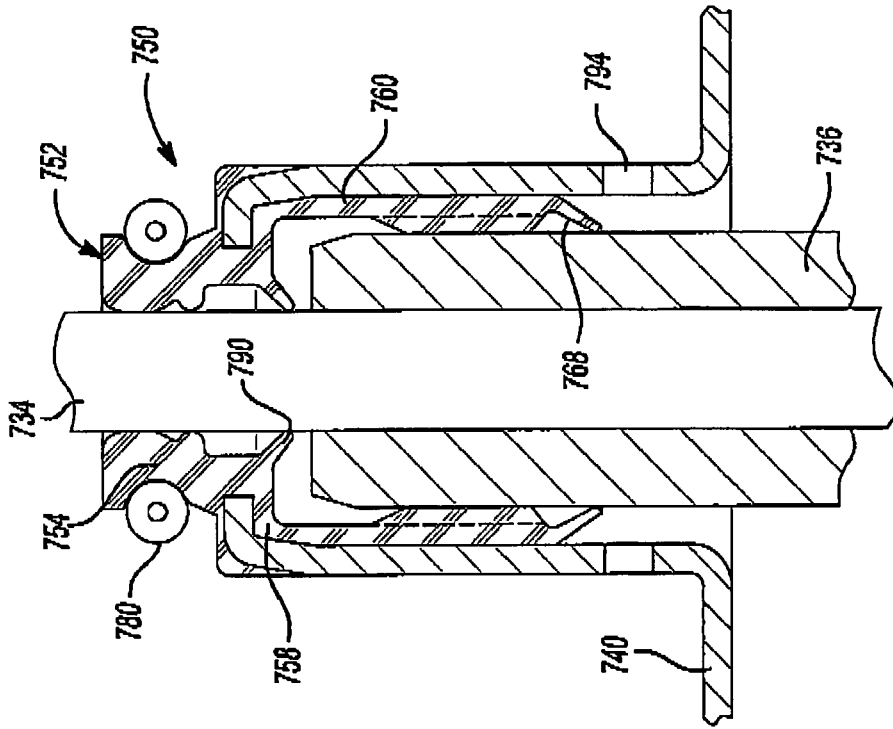
**Fig-8**



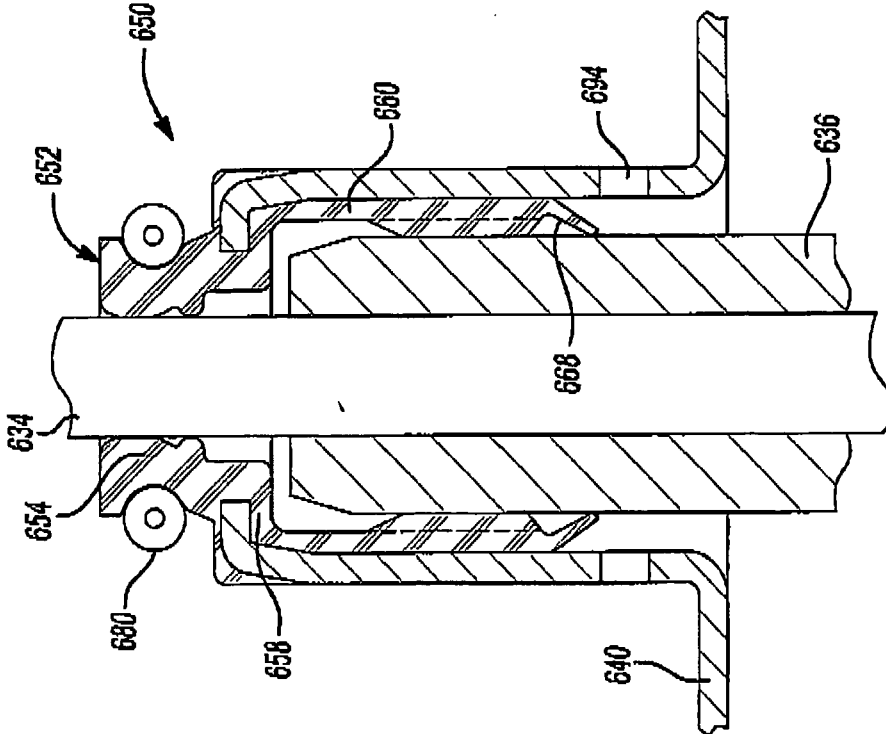
**Fig-7**



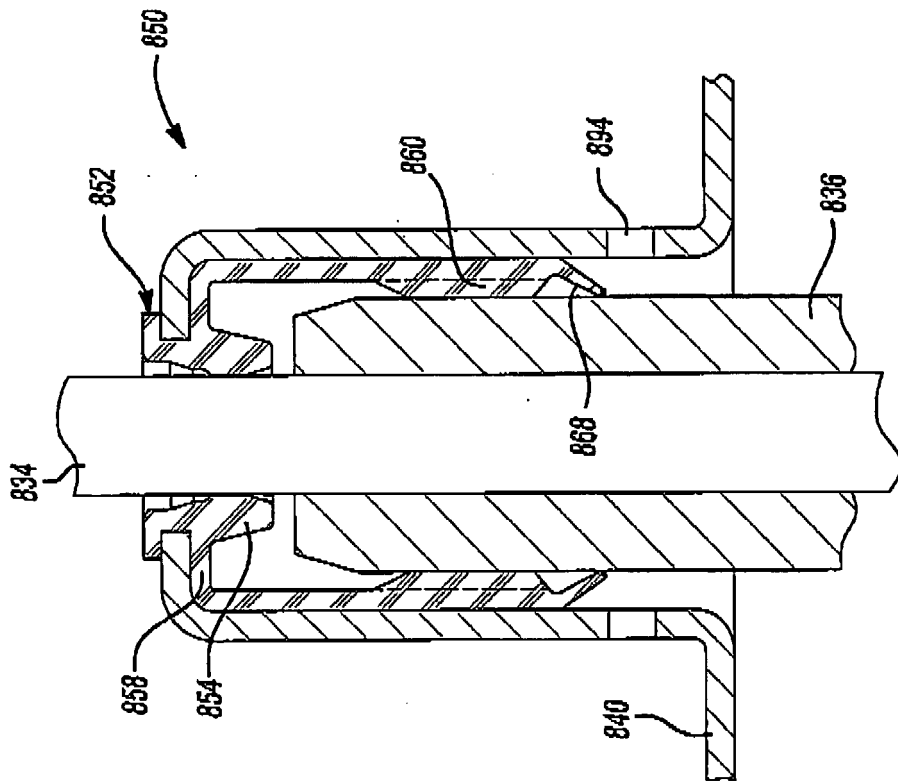
**Fig-9**



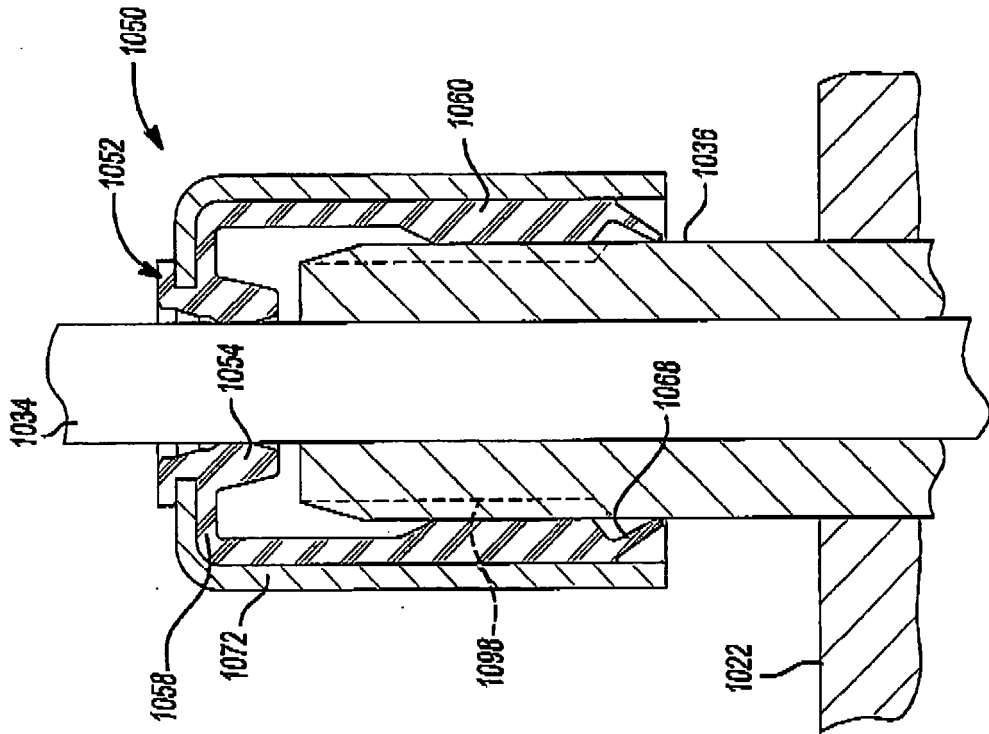
**Fig-11**



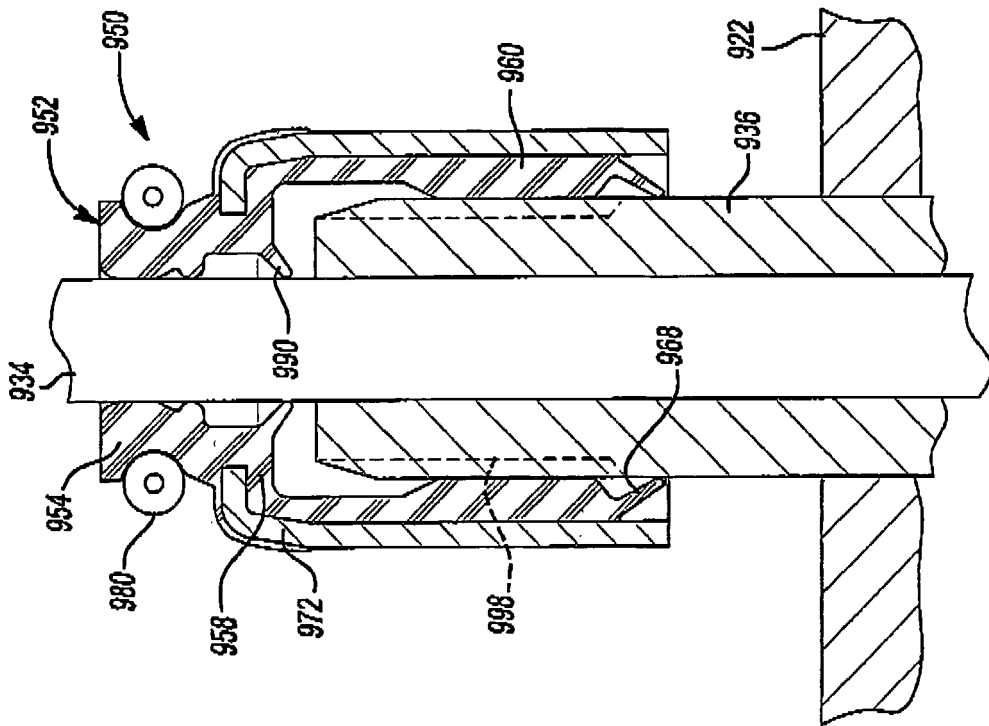
**Fig-10**



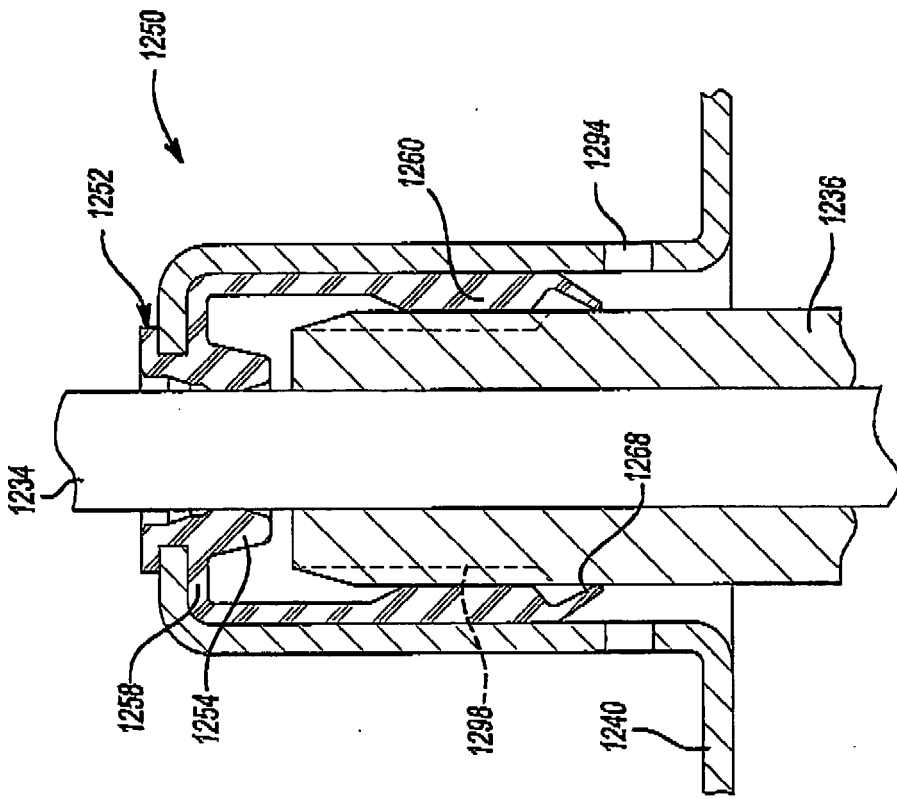
**Fig-12**



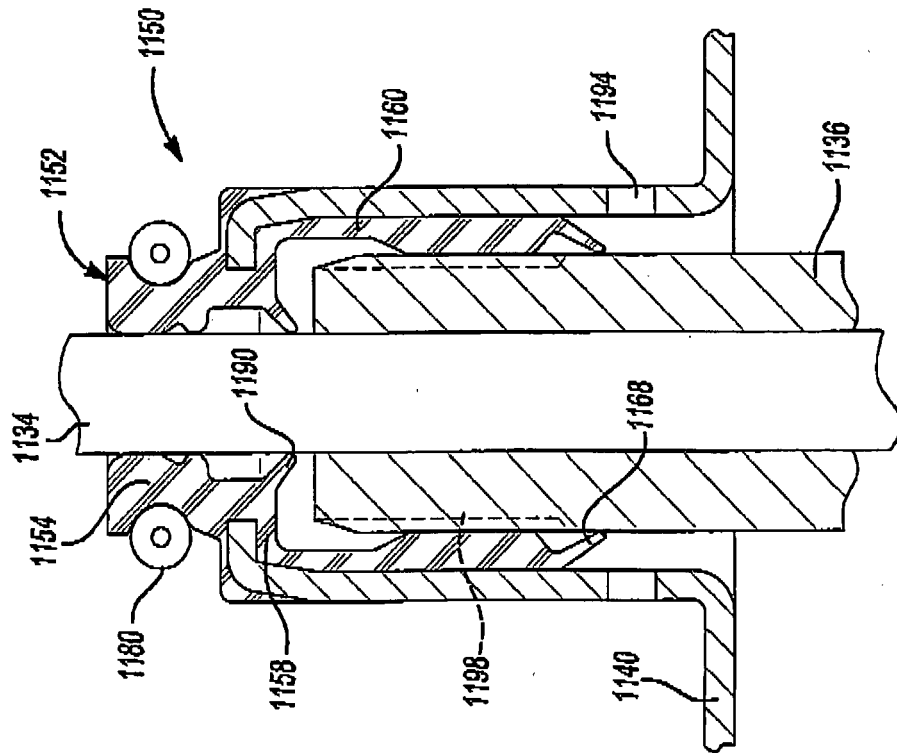
**Fig-14**



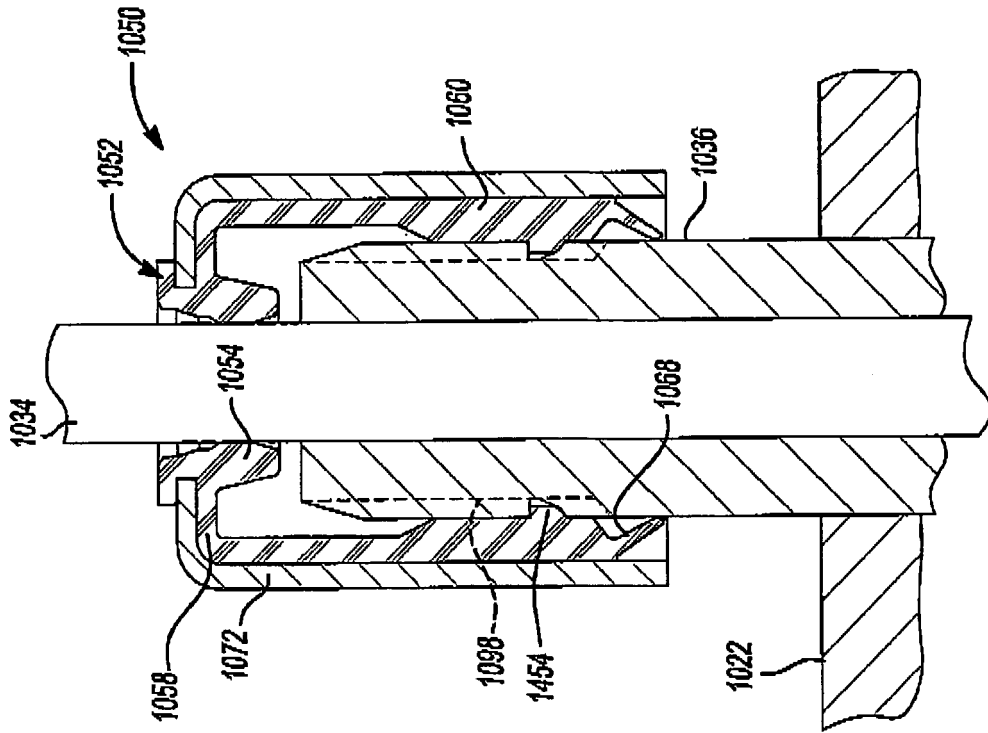
**Fig-13**



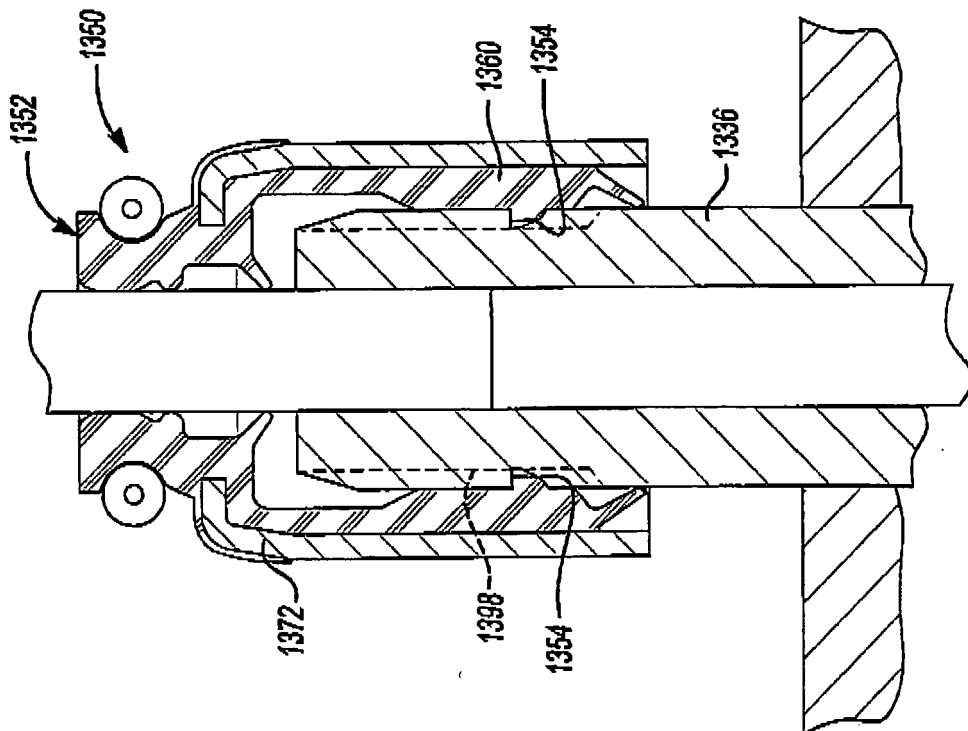
**Fig-16**



**Fig-15**



**Fig-18**



**Fig-17**

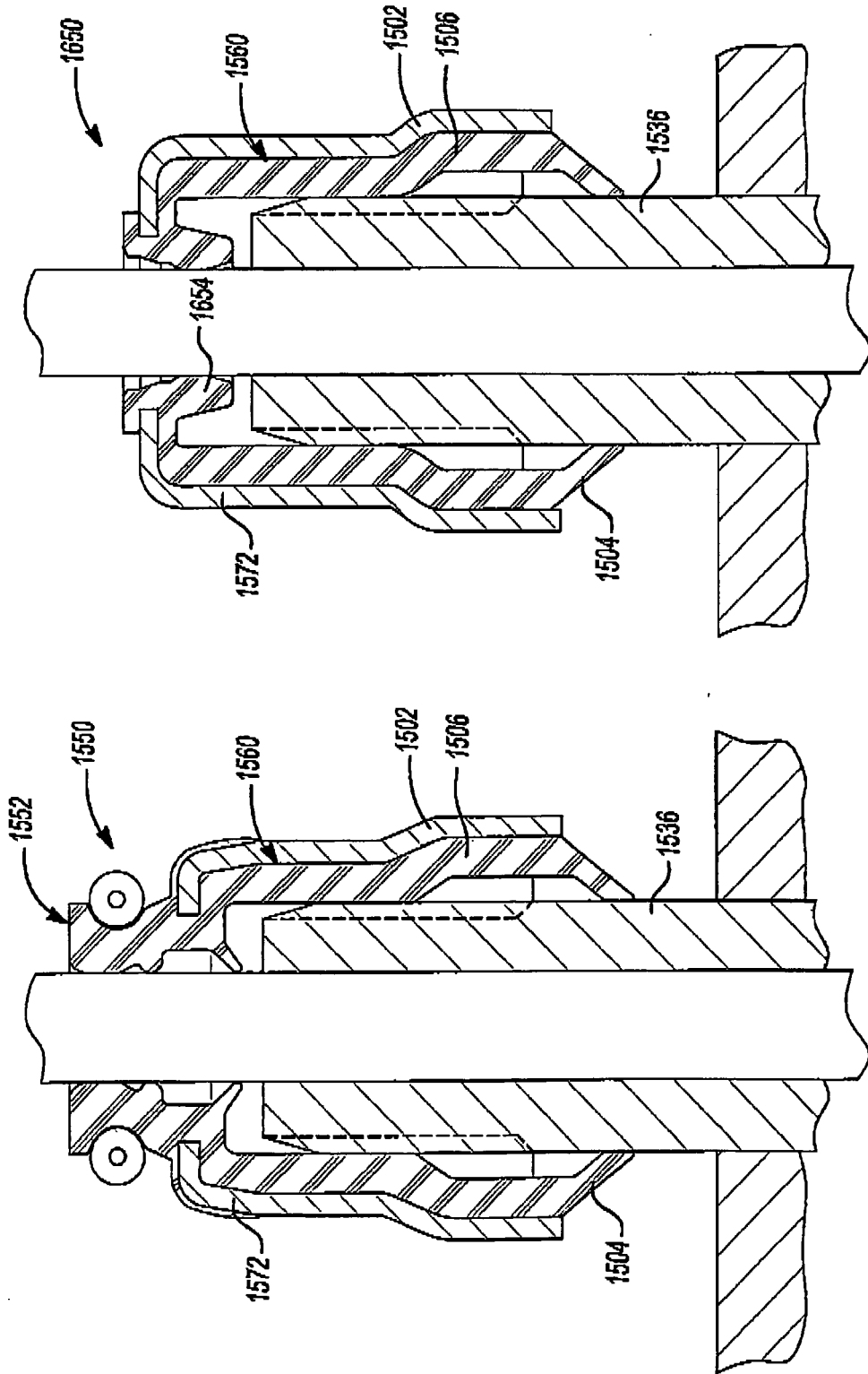


Fig-20

Fig-19

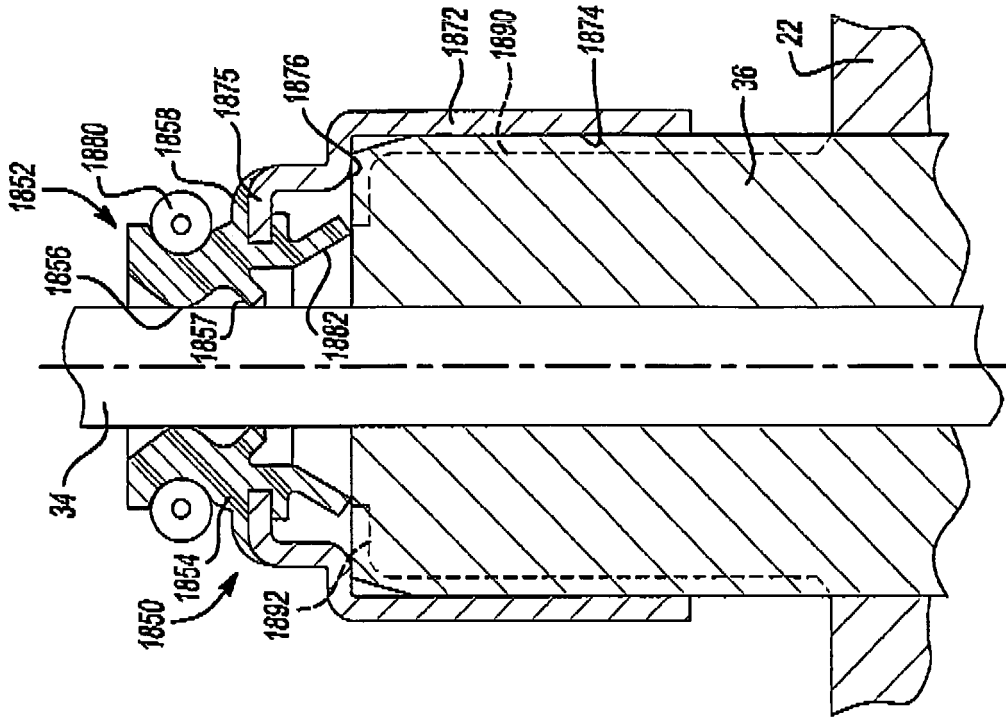


Fig-22

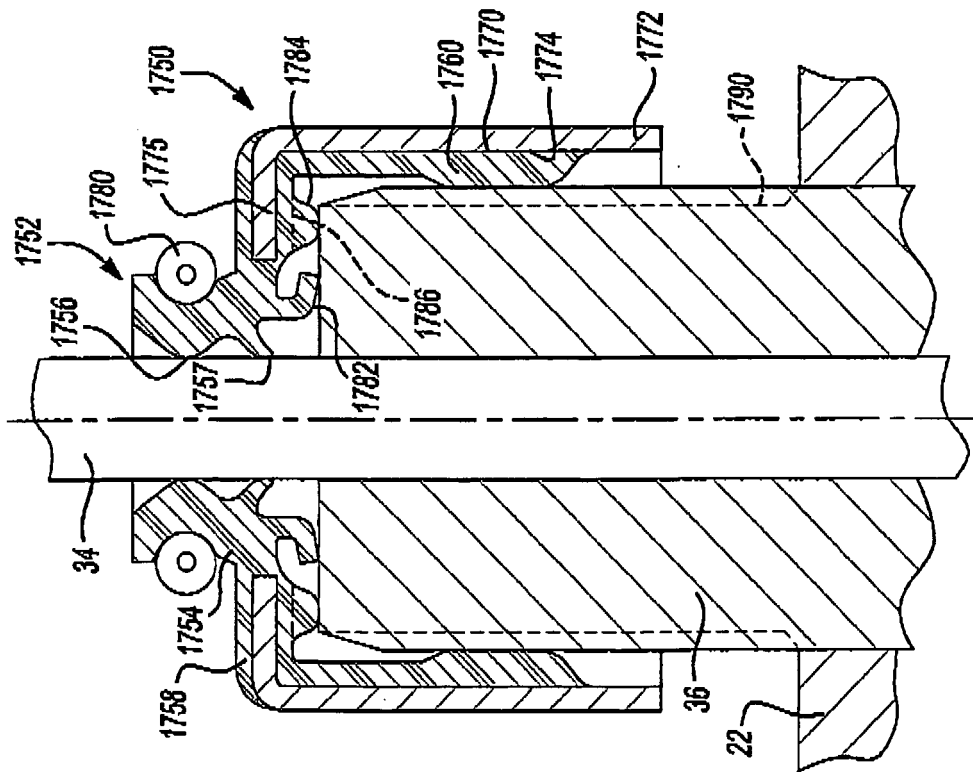
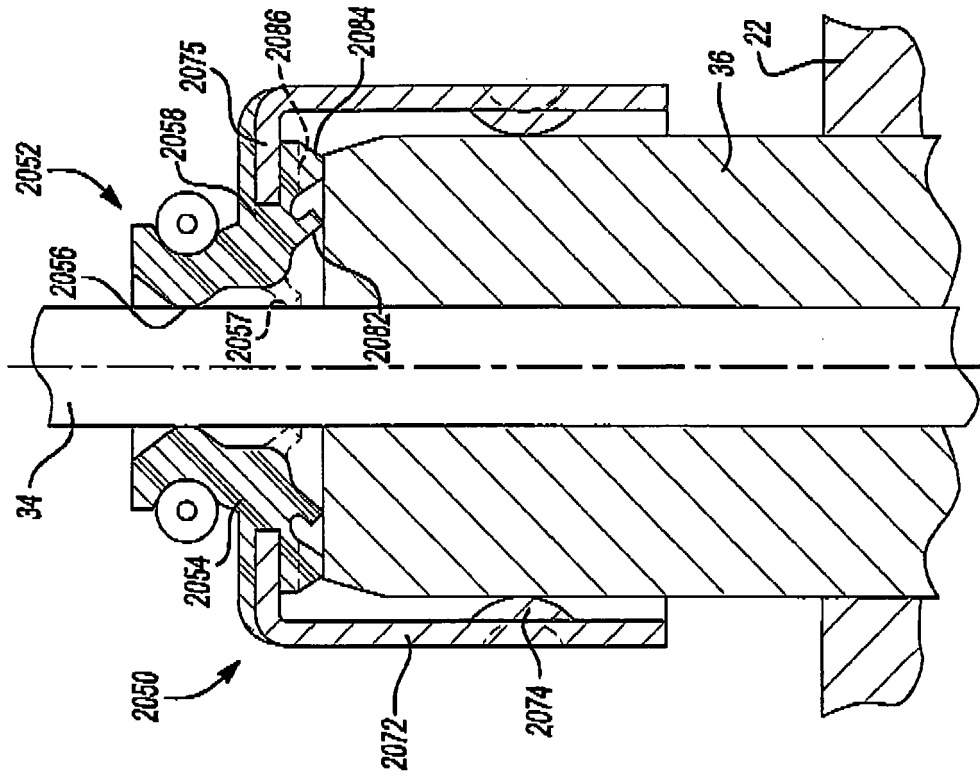
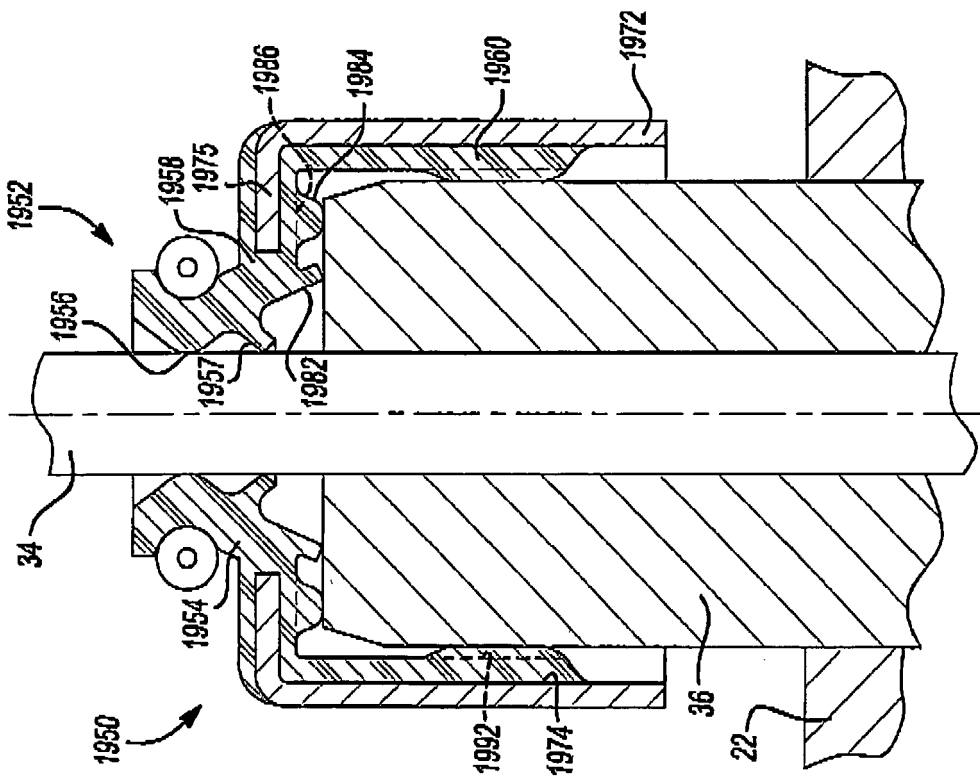


Fig-21



**Fig-24**



**Fig-23**

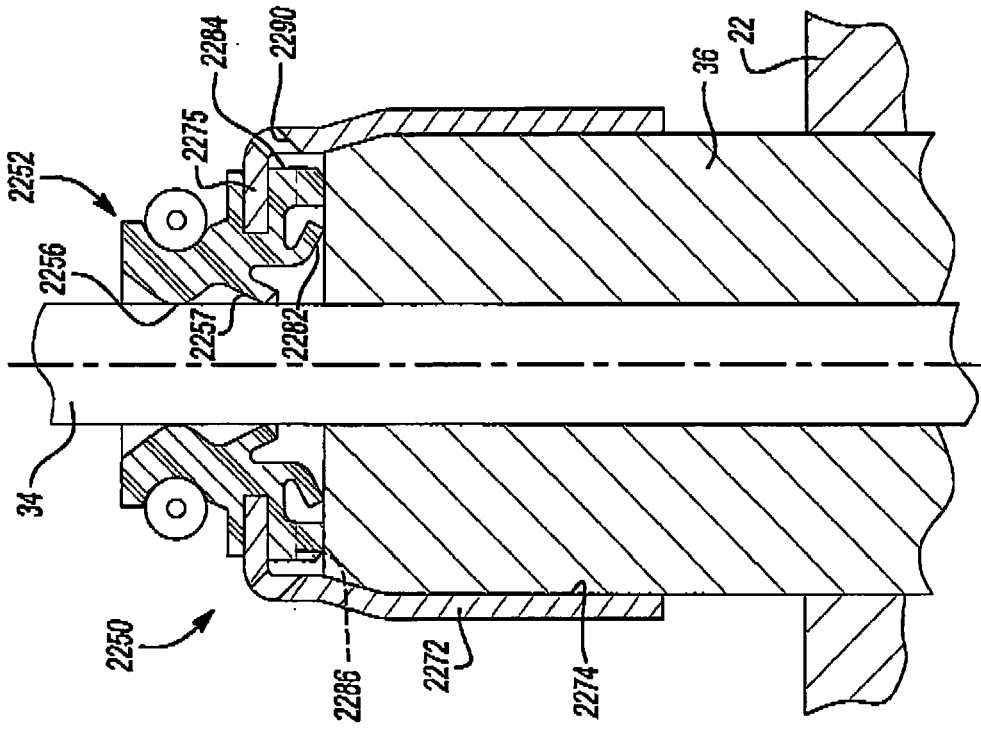


Fig-26

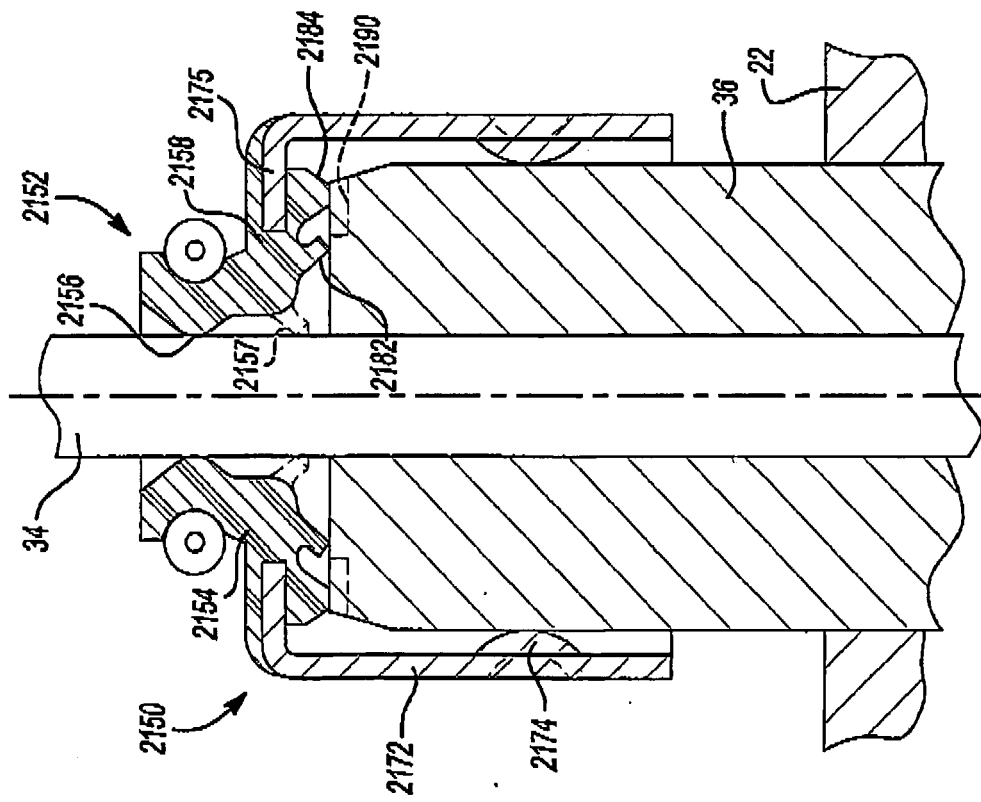


Fig-25

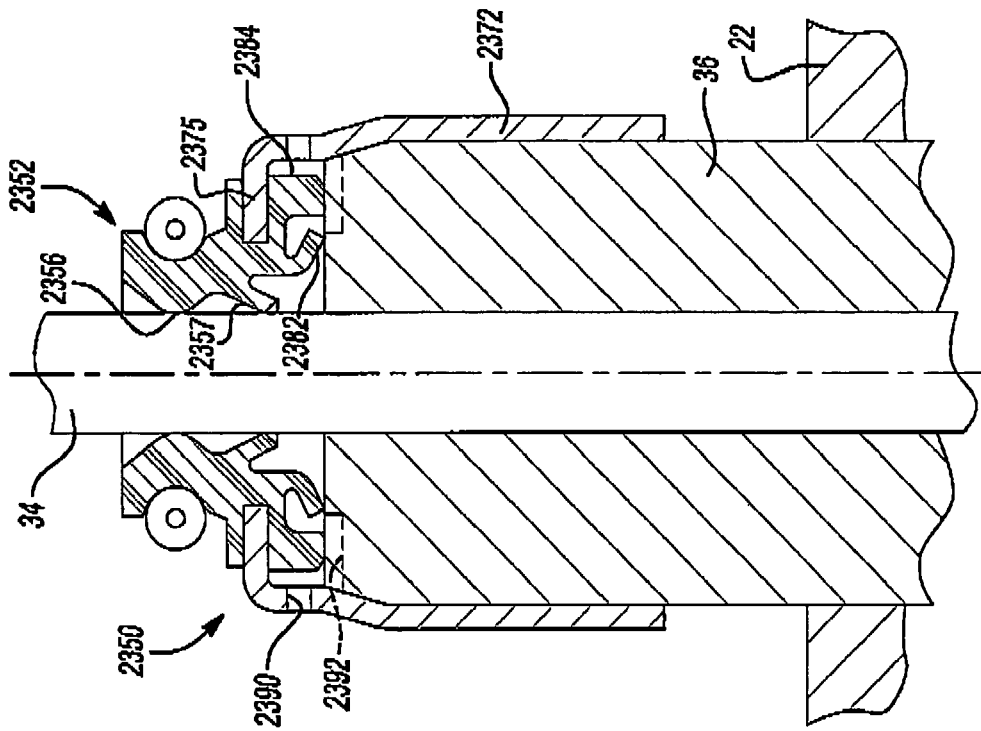


Fig-27



Europäisches  
Patentamt  
European  
Patent Office  
Office européen  
des brevets

## EUROPEAN SEARCH REPORT

Application Number  
EP 09 00 5463

DOCUMENTS CONSIDERED TO BE RELEVANT			
Category	Citation of document with indication, where appropriate, of relevant passages	Relevant to claim	CLASSIFICATION OF THE APPLICATION (IPC)
A	DE 38 36 578 A1 (GOETZE AG [DE]) 3 May 1990 (1990-05-03) * column 3, line 2 - line 35 * * figures *	1,3,7, 9-10,13	INV. F01L3/08
A	JP 2003 042301 A (NOK CORP) 13 February 2003 (2003-02-13) * paragraph [0017] - paragraph [0019]; figures * * abstract *	1,3,7, 9-10,13	
A	US 2005/040603 A1 (LEIMER MARK A [US]) 24 February 2005 (2005-02-24) * paragraph [0001] * * paragraph [0018] * * figures 1,2,5 *	1,3,7, 9-10,13	
A	JP 2003 343733 A (NOK CORP) 3 December 2003 (2003-12-03) * abstract; figures *	1,3,7, 9-10,13	
A	EP 1 884 630 A1 (FREUDENBERG CARL KG [DE]) 6 February 2008 (2008-02-06) * the whole document *	1,7, 9-10,13	TECHNICAL FIELDS SEARCHED (IPC) F01L
A	US 2002/117140 A1 (MCARTHY TROY DANIEL [US]) 29 August 2002 (2002-08-29) * paragraph [0002] * * paragraph [0009] * * paragraph [0018] * * figures *	3	
The present search report has been drawn up for all claims			
Place of search The Hague		Date of completion of the search 18 September 2009	Examiner Paquay, Jeannot
CATEGORY OF CITED DOCUMENTS X : particularly relevant if taken alone Y : particularly relevant if combined with another document of the same category A : technological background O : non-written disclosure P : intermediate document		T : theory or principle underlying the invention E : earlier patent document, but published on, or after the filing date D : document cited in the application L : document cited for other reasons & : member of the same patent family, corresponding document	

1  
EPO FORM 1503\_03\_02 (P04C01)

**ANNEX TO THE EUROPEAN SEARCH REPORT  
ON EUROPEAN PATENT APPLICATION NO.**

EP 09 00 5463

This annex lists the patent family members relating to the patent documents cited in the above-mentioned European search report. The members are as contained in the European Patent Office EDP file on  
The European Patent Office is in no way liable for these particulars which are merely given for the purpose of information.

18-09-2009

Patent document cited in search report	Publication date	Patent family member(s)	Publication date
DE 3836578 A1	03-05-1990	NONE	
JP 2003042301 A	13-02-2003	NONE	
US 2005040603 A1	24-02-2005	MX PA04008102 A	26-10-2005
JP 2003343733 A	03-12-2003	JP 4092548 B2	28-05-2008
EP 1884630 A1	06-02-2008	JP 2008039026 A	21-02-2008
US 2002117140 A1	29-08-2002	CA 2372019 A1	26-08-2002
		MX PA02002021 A	30-09-2002