

(19) World Intellectual Property Organization
International Bureau



(43) International Publication Date
24 September 2009 (24.09.2009)

(10) International Publication Number
WO 2009/117238 A2

- (51) International Patent Classification:
B81C 1/00 (2006.01)
- (21) International Application Number:
PCT/US2009/035804
- (22) International Filing Date:
3 March 2009 (03.03.2009)
- (25) Filing Language: English
- (26) Publication Language: English
- (30) Priority Data:
12/053,006 21 March 2008 (21.03.2008) US
- (71) Applicant (for all designated States except US): **MI-CRON TECHNOLOGY, INC.** [US/US]; 8000 South Federal Way, Boise, ID 83716 (US).
- (72) Inventor; and
- (75) Inventor/Applicant (for US only): **REGNER, Jennifer, Kahl** [US/US]; 5568 N. Powell Creek Avenue, Meridian, ID 83646 (US).
- (74) Agent: **STRODTHOFF, Kristine, M.**; Whyte Hirschboeck Dudek S.C., 555 East Wells Street, Suite 1900, Milwaukee, WI 53202 (US).

- (81) Designated States (unless otherwise indicated, for every kind of national protection available): AE, AG, AL, AM, AO, AT, AU, AZ, BA, BB, BG, BH, BR, BW, BY, BZ, CA, CH, CN, CO, CR, CU, CZ, DE, DK, DM, DO, DZ, EC, EE, EG, ES, FI, GB, GD, GE, GH, GM, GT, HN, HR, HU, ID, IL, IN, IS, JP, KE, KG, KM, KN, KP, KR, KZ, LA, LC, LK, LR, LS, LT, LU, LY, MA, MD, ME, MG, MK, MN, MW, MX, MY, MZ, NA, NG, NI, NO, NZ, OM, PG, PH, PL, PT, RO, RS, RU, SC, SD, SE, SG, SK, SL, SM, ST, SV, SY, TJ, TM, TN, TR, TT, TZ, UA, UG, US, UZ, VC, VN, ZA, ZM, ZW.
- (84) Designated States (unless otherwise indicated, for every kind of regional protection available): ARIPO (BW, GH, GM, KE, LS, MW, MZ, NA, SD, SL, SZ, TZ, UG, ZM, ZW), Eurasian (AM, AZ, BY, KG, KZ, MD, RU, TJ, TM), European (AT, BE, BG, CH, CY, CZ, DE, DK, EE, ES, FI, FR, GB, GR, HR, HU, IE, IS, IT, LT, LU, LV, MC, MK, MT, NL, NO, PL, PT, RO, SE, SI, SK, TR), OAPI (BF, BJ, CF, CG, CI, CM, GA, GN, GQ, GW, ML, MR, NE, SN, TD, TG).

Published:

- without international search report and to be republished upon receipt of that report (Rule 48.2(g))

(54) Title: METHODS OF IMPROVING LONG RANGE ORDER IN SELF-ASSEMBLY OF BLOCK COPOLYMER FILMS WITH IONIC LIQUIDS

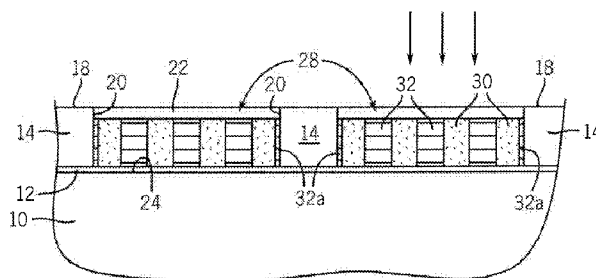

FIG. 6A

(57) Abstract: Methods for fabricating arrays of nanoscaled alternating lamellae or cylinders in a polymer matrix having improved long range order utilizing self-assembling block copolymers, and films and devices formed from these methods are provided.

WO 2009/117238 A2

METHODS OF IMPROVING LONG RANGE ORDER IN SELF-ASSEMBLY OF BLOCK COPOLYMER FILMS WITH IONIC LIQUIDS

TECHNICAL FIELD

[0001] Embodiments of the invention relate to methods of fabricating thin films of self-assembling block copolymers, and devices resulting from those methods.

BACKGROUND OF THE INVENTION

[0002] As the development of nanoscale mechanical, electrical, chemical and biological devices and systems increases, new processes and materials are needed to fabricate nanoscale devices and components. Making electrical contacts to conductive lines has become a significant challenge as the dimensions of semiconductor features shrink to sizes that are not easily accessible by conventional lithography. Optical lithographic processing methods have difficulty fabricating structures and features at the sub-60 nanometer level. The use of self assembling diblock copolymers presents another route to patterning at nanoscale dimensions. Diblock copolymer films spontaneously assemble into periodic structures by microphase separation of the constituent polymer blocks after annealing, for example by thermal annealing above the glass transition temperature of the polymer or by solvent annealing, forming ordered domains at nanometer-scale dimensions.

[0003] The film morphology, including the size and shape of the microphase-separated domains, can be controlled by the molecular weight and volume fraction of the AB blocks of a diblock copolymer to produce lamellar, cylindrical, or spherical morphologies, among others. For example, for volume fractions at ratios greater than about 80:20 of the two blocks (AB) of a diblock polymer, a block copolymer film will microphase separate and self-assemble into a periodic spherical domains with spheres of polymer B surrounded by a matrix of polymer A. For ratios of the two blocks between about 60:40 and 80:20, the diblock copolymer assembles into a periodic hexagonal close-packed or honeycomb array of cylinders of polymer B within a matrix of polymer A. For ratios between about 50:50 and 60:40, lamellar domains or alternating stripes of the blocks are formed. Domain size typically ranges from 5-50 nm.

[0004] Attempts have been made to control orientation and long range ordering of self-assembling block copolymer materials. Salts such as sodium and potassium chloride (NaCl, KCl) have been shown to improve long range ordering of block copolymer material on substrates. However, the sodium (Na) and potassium (K) are highly mobile, which can result in contamination of other device structures during processing. Other researches have added organic surfactants to diblock copolymers to improve long range ordering during self-assembly. However, during the high temperature/vacuum anneal of the block copolymer material, the organic surfactant evaporates from the film before the self-assembly process is completed, limiting the annealing conditions that can be used.

[0005] It would be useful to provide methods of fabricating films of ordered nanostructures that overcome these problems and provide enhanced long range ordering of the self-assembling polymer domains.

BRIEF DESCRIPTION OF THE DRAWINGS

[0006] Embodiments of the invention are described below with reference to the following accompanying drawings, which are for illustrative purposes only. Throughout the following views, the reference numerals will be used in the drawings, and the same reference numerals will be used throughout the several views and in the description to indicate same or like parts.

[0007] **FIG. 1** illustrates a diagrammatic top plan view of a portion of a substrate at a preliminary processing stage according to an embodiment of the present disclosure, showing the substrate with a neutral wetting material thereon. **FIG. 1A** is an elevational, cross-sectional view of the substrate depicted in **FIG. 1** taken along line 1A-1A.

[0008] **FIG. 2** illustrates a top plan view of the substrate of **FIG. 1** at a subsequent stage showing the formation of trenches in a material layer formed on the neutral wetting material. **FIG. 2A** illustrates an elevational, cross-sectional view of a portion of the substrate depicted in **FIG. 2** taken along line 2A-2A.

[0009] **FIG. 3** illustrates a side elevational view of a portion of a substrate at a preliminary processing stage according to another embodiment of the disclosure, showing the

substrate with trenches in a material layer formed on the substrate. FIG. 4 illustrates a side elevational view of the substrate of FIG. 3 at a subsequent stage showing the formation of a neutral wetting material within the trenches.

[0010] FIGS. 5-6 are diagrammatic top plan views of the substrate of FIG. 2 at subsequent stages in the fabrication of a self-assembled block copolymer film according to an embodiment of the disclosure utilizing a lamellar-phase block copolymer material. FIGS. 5A-6A illustrate elevational, cross-sectional views of a portion of the substrate depicted in FIGS. 5-6 taken along lines 5A-5A and 6A-6A, respectively.

[0011] FIGS. 7-8 are top plan views of the substrate of FIG. 6 at subsequent stages, illustrating an embodiment of the use of the self-assembled block copolymer film after removal of one of the polymer blocks as a mask to etch the substrate and filling of the etched openings. FIGS. 7A-8A illustrate elevational, cross-sectional views of a portion of the substrate depicted in FIGS. 7-8 taken along lines 7A-7A and 8A-8A, respectively.

[0012] FIG. 9 is a top plan view of the substrate of FIG. 6 at a subsequent stage according to another embodiment after removal of polymer blocks with residual inorganic material as a mask on the substrate. FIG. 9A is an elevational, cross-sectional view of a portion of the substrate depicted in FIG. 9 taken along lines 9A-9A.

[0013] FIG. 10 is a diagrammatic top plan view of a portion of a substrate at a preliminary processing stage according to another embodiment of the disclosure, showing trenches in a material layer exposing the substrate. FIGS. 10A-10B are elevational, cross-sectional views of the substrate depicted in FIG. 10 taken along lines 10A-10A and 10B-10B, respectively.

[0014] FIGS. 11-12 are diagrammatic top plan views of the substrate of FIG. 10 at subsequent stages in the fabrication of a self-assembled block copolymer film composed of a single row of perpendicular oriented cylinders in a polymer matrix within the trenches according to an embodiment of the disclosure. FIGS. 11A-12A illustrate elevational, cross-sectional views of a portion of the substrate depicted in FIGS. 11-12 taken along

lines 11A-11A and 12A-12A, respectively. FIGS. 11B-12B are cross-sectional views of the substrate depicted in FIGS. 11-12 taken along lines 11B-11B and 12B-12B, respectively.

[0015] FIGS. 13-14 are top plan views of the substrate of FIG. 12 at subsequent stages, illustrating an embodiment of the use of the self-assembled block copolymer film after removal of one of the cylindrical domains, as a mask to etch the substrate and filling of the etched openings. FIGS. 13A-14A illustrate elevational, cross-sectional views of a portion of the substrate depicted in FIGS. 13-14 taken along lines 13A-13A to 14A-14A, respectively. FIGS. 13B-14B are cross-sectional views of the substrate depicted in FIGS. 13-14 taken along lines 13B-13B to 14B-14B, respectively.

DETAILED DESCRIPTION OF THE INVENTION

[0016] The following description with reference to the drawings provides illustrative examples of devices and methods according to embodiments of the invention. Such description is for illustrative purposes only and not for purposes of limiting the same.

[0017] In the context of the current application, the term "semiconductor substrate" or "semiconductive substrate" or "semiconductive wafer fragment" or "wafer fragment" or "wafer" will be understood to mean any construction comprising semiconductor material, including but not limited to bulk semiconductive materials such as a semiconductor wafer (either alone or in assemblies comprising other materials thereon), and semiconductive material layers (either alone or in assemblies comprising other materials). The term "substrate" refers to any supporting structure including, but not limited to, the semiconductive substrates, wafer fragments or wafers described above.

[0018] " L_o " as used herein is the inherent periodicity or pitch value (bulk period or repeat unit) of structures that self assemble upon annealing from a self-assembling (SA) block copolymer. " L_B " as used herein is the periodicity or pitch value of a blend of a block copolymer with one or more of its constituent homopolymers. " L " is used herein to indicate the center-to-center cylinder pitch or spacing of cylinders of the block copolymer or blend, and is equivalent to " L_o " for a pure block copolymer and " L_B " for a copolymer blend.

[0019] In embodiments of the invention, a polymer material (e.g., film, layer) is prepared by guided self-assembly of block copolymers, with both polymer domains at the air interface. Block copolymer materials spontaneously assemble into periodic structures by microphase separation of the constituent polymer blocks after annealing, forming ordered domains at nanometer-scale dimensions. In embodiments of the invention, an ordered linear array pattern registered to the trench sidewalls is formed within a trench from a lamellar-phase block copolymer material. In other embodiments of the invention, a one-dimensional (1-D) array of perpendicular-oriented cylinders is formed within a trench from a cylindrical-phase block copolymer material.

[0020] Embodiments of the invention pertain to the improved long range order imparted by addition of an appropriate ionic liquid to the block copolymer material, such ionic liquid selected to perform one or more functions in the block copolymer blend, for example, a surfactant/plasticizer effect and a phase-selective complexation role.

[0021] Following self assembly, the pattern of perpendicular-oriented lamellae or cylinders that is formed on the substrate can then be used, for example, to form an etch mask for patterning nanosized features into the underlying substrate through selective removal of one block of the self-assembled block copolymer. Since the domain sizes and periods (L) involved in this method are determined by the chain length of a block copolymer (MW), resolution can exceed other techniques such as conventional photolithography. Processing costs using the technique are significantly less than extreme ultraviolet (EUV) photolithography, which has comparable resolution.

[0022] A method for fabricating a self-assembled block copolymer material that defines an array of nanometer-scale, perpendicular-oriented lamellae according to an embodiment of the invention is illustrated with reference to **FIGS. 1-6**.

[0023] The described embodiment involves an anneal of a lamellar-phase block copolymer material formulated with an ionic liquid in combination with a graphoeptaxy technique that utilizes a lithographically defined trench as a guide with a floor composed of a material that is neutral wetting to both polymer blocks and sidewalls and ends that are preferential wetting to one polymer block and function as constraints to induce self assembly

of the block copolymer material. Upon annealing, the block copolymer material will self-assemble into rows or lines of lamellae oriented perpendicular to the trench floor and registered to the sidewalls.

[0024] As depicted in FIGS. 1-1A, a substrate 10 is provided, which can be, for example, silicon, silicon oxide, silicon nitride, silicon oxynitride, silicon oxycarbide, among other materials.

[0025] In the illustrated embodiment, a neutral wetting material 12 (e.g., random copolymer) has been formed over the substrate 10. A material layer 14 (or one or more material layers) can then be formed over the neutral wetting material and etched to form trenches 16 as shown in FIGS. 2-2A. Portions of the material layer 14 form a mesa or spacer 18 outside and between the trenches. The trenches 16 are structured with opposing sidewalls 20, opposing ends 22, a floor 24, a width (w_t), a length (l_t) and a depth (D_t).

[0026] In another embodiment illustrated in FIGS. 3-4, the material layer 14' can be formed on the substrate 10', etched to form the trenches 16', and a neutral wetting material 12' can then be formed on the trench floors 24'. For example, a random copolymer material can be deposited into the trenches and crosslinked to form a neutral wetting material layer. Material on surfaces outside the trenches such as on the spacers 18' (e.g., non-crosslinked random copolymer) can be subsequently removed.

[0027] Single or multiple trenches 16 (as shown) can be formed in the material layer 14 using a lithographic tool having an exposure system capable of patterning at the scale of L (e.g., about 10-100 nm). Such exposure systems include, for example, extreme ultraviolet (EUV) lithography, proximity X-rays and electron beam (e-beam) lithography, as known and used in the art. Conventional photolithography can attain (at smallest) about 58 nm features.

[0028] A method called "pitch doubling" or "pitch multiplication" can also be used for extending the capabilities of photolithographic techniques beyond their minimum pitch, as described, for example, in U.S. Pat. No. 5,328,810 (Lowrey et al.), U.S. Pat. No. 7,115,525 (Abatchev, et al.), US 2006/0281266 (Wells) and US 2007/0023805 (Wells). Briefly, a

pattern of lines is photolithographically formed in a photoresist material overlying a layer of an expendable material, which in turn overlies a substrate, the expendable material layer is etched to form placeholders or mandrels, the photoresist is stripped, spacers are formed on the sides of the mandrels, and the mandrels are then removed leaving behind the spacers as a mask for patterning the substrate. Thus, where the initial photolithography formed a pattern defining one feature and one space, the same width now defines two features and two spaces, with the spaces defined by the spacers. As a result, the smallest feature size possible with a photolithographic technique is effectively decreased down to about 30 nm or less.

[0029] Generally, the trench sidewalls, edges and floors influence the structuring of the array of nanostructures within the trenches. Factors in forming a single line or multiple lines of perpendicular-oriented lamellae within the trenches include the width (w_t) of the trench, the formulation of the block copolymer or blend to achieve the desired pitch (L), and the thickness (t) of the block copolymer material within the trench at the time of the anneal. The boundary conditions of the trench sidewalls in both the x- and y-axis impose a structure wherein each trench contains n number of lamellae.

[0030] In the present embodiment, the width (w_t) of the trench can be varied according to the desired number of rows of perpendicular-oriented lamellae (e.g., n lines of lamellae). The width (w_t) of the trenches is generally a multiple of the inherent pitch value (L) of the block copolymer material being equal to or about $n*L$, typically ranging from about $n*10$ to about $n*100$ nm (with n being the number of features or structures, e.g., lamellae).

[0031] In the illustrated embodiment, the trenches 16 are constructed with a width (w_t) that is greater than the L or pitch value of the block copolymer (or blend) such that the lamellar-phase block copolymer material will self assemble upon annealing to form a single layer of multiple rows of lamellae spanning the width (w_t) of the trench and registered to the sidewalls for the length of the trench, with a repeat spacing of domains (e.g., PMMA lamellae) having a center-to-center pitch distance (p) at about the L value. The length (l) of the trenches 16 is according to the desired length of the lines of the lamellae. The width of the mesas or spacers 18 between adjacent trenches can vary and is generally about L to

about $n*L$. In some embodiments, the trench dimension is about 50-3,500 nm wide (w_t) and about 100-25,000 nm in length (l_t), with a depth (D_t) of about 10-500 nm.

[0032] In the described embodiment, the trench floors 24 are structured to be neutral wetting (equal affinity) for both blocks of the block copolymer to induce formation of lamellar polymer domains that are oriented perpendicular to the trench floors, and the trench sidewalls 20 and ends 22 are structured to be preferential wetting by one block of the block copolymer to induce a parallel alignment and registration of the lamellae to the sidewalls as the polymer blocks self-assemble.

[0033] To provide preferential wetting sidewalls and ends, the material layer 14 can be formed from a material that is inherently preferential wetting to the minority (preferred) polymer block (e.g., PMMA of a PS-b-PMMA material) or, in other embodiments, a preferential wetting material can be selectively applied onto the sidewalls of the trenches 16. For example, the material layer 14 can be composed of an inherently preferential wetting material such as a clean silicon surface (with native oxide), oxide (e.g., silicon oxide, SiO_x), silicon nitride, silicon oxycarbide, indium tin oxide (ITO), silicon oxynitride, and resist materials such as methacrylate-based resists and polydimethyl glutarimide resists, among other materials. Such materials exhibit preferential wetting toward PMMA or PVP, among others.

[0034] In other embodiments utilizing PS-b-PMMA, a preferential wetting material such as a polymethylmethacrylate (PMMA) polymer modified with an -OH containing moiety (e.g., hydroxyethylmethacrylate) can be selectively applied onto the sidewalls of the trenches in embodiments where a neutral wetting material 12 is in place on the trench floor 24 as in FIGS. 2A and FIG. 4). If not, as in FIG. 3, the substrate 10' at the trench floor 24' can be composed of a material that is unreactive with the OH-modified PMMA. An OH-modified PMMA can be applied, for example, by spin coating and then heating (e.g., to about 170°C) to allow the terminal OH groups to end-graft to oxide sidewalls 20 and ends 22 of the trenches. Non-grafted material can be removed by rinsing with an appropriate solvent (e.g., toluene). See, for example, Mansky et al., *Science*, 1997, 275, 1458-1460, and In et al., *Langmuir*, 2006, 22, 7855-7860.

[0035] A chemically neutral wetting trench floor 24 allows both blocks of the block copolymer material to wet the floor of the trench and provides for the formation of a perpendicular-oriented lamellar layout. A neutral wetting material 12 can be provided by applying a neutral wetting polymer (e.g., a neutral wetting random copolymer) onto the substrate 10, then forming an overlying material layer 14 and etching the trenches 16 to expose the underlying neutral wetting material, as illustrated in FIGS. 2-2A.

[0036] In another embodiment illustrated in FIGS. 3-4, a neutral wetting material can be applied after forming the trenches 16', for example, as a blanket coat by casting or spin-coating into the trenches, as depicted in FIG. 4. For example, a random copolymer material can be applied and then thermally processed to flow the material into the bottom of the trenches by capillary action, which results in a layer (mat) 12' composed of the crosslinked, neutral wetting random copolymer. In another embodiment, a random copolymer material within the trenches can be photo-exposed (e.g., through a mask or reticle) to crosslink the random copolymer within the trenches to form the neutral wetting material 12'. Non-crosslinked random copolymer material outside the trenches (e.g., on the spacers 18') can be subsequently removed.

[0037] Neutral wetting surfaces can be specifically prepared by the application of random copolymers composed of monomers identical to those in the block copolymer and tailored such that the mole fraction of each monomer is appropriate to form a neutral wetting surface. For example, in the use of a PS-b-PMMA block copolymer, a neutral wetting material 12 can be formed from a thin film of a photo-crosslinkable random PS-r-PMMA that exhibits non-preferential or neutral wetting toward PS and PMMA, which can be cast onto the substrate 10 (e.g., by spin coating). The random copolymer material can be fixed in place by chemical grafting (on an oxide substrate) or by thermally or photolytically crosslinking (any surface) to form a mat that is neutral wetting to PS and PMMA and insoluble when the block copolymer material is cast onto it, due to the crosslinking.

[0038] In embodiments in which the substrate 10 is silicon (with native oxide), another neutral wetting surface for PS-b-PMMA can be provided by hydrogen-terminated silicon. The floors 24 of the trenches 16 can be etched, for example, with a hydrogen plasma, to

remove the oxide material and form hydrogen-terminated silicon, which is neutral wetting with equal affinity for both blocks of a block copolymer material. H-terminated silicon can be prepared by a conventional process, for example, by a fluoride ion etch of a silicon substrate (with native oxide present, about 12-15 Å) by exposure to an aqueous solution of hydrogen fluoride (HF) and buffered HF or ammonium fluoride (NH₄F), by HF vapor treatment, or by a hydrogen plasma treatment (e.g., atomic hydrogen).

[0039] An H-terminated silicon substrate can be further processed by grafting a random copolymer such as PS-r-PMMA, PS-r-PVP, etc., selectively onto the substrate resulting in a neutral wetting surface for the corresponding block copolymer (e.g., PS-b-PMMA, PS-b-PVP, etc.). For example, a neutral wetting layer of PS-r-PMMA random copolymer can be provided by an *in situ* free radical polymerization of styrene and methyl methacrylate using a di-olefinic linker such as divinyl benzene which links the polymer to an H-terminated silicon surface to produce about a 10-15 nm thick film.

[0040] In yet another embodiment, a neutral wetting surface (e.g., PS-b-PMMA and PS-b-PEO) can be provided by grafting a self-assembled monolayer (SAM) of a trichlorosilane-base SAM such as 3-(para-methoxyphenyl)propyltrichlorosilane grafted to oxide (e.g., SiO₂) as described for example, by D.H. Park, *Nanotechnology* 18 (2007), p. 355304.

[0041] A surface that is neutral wetting to PS-b-PMMA can also be prepared by spin coating a blanket layer of a photo- or thermally cross-linkable random copolymer such as a benzocyclobutene- or azidomethylstyrene-functionalized random copolymer of styrene and methyl methacrylate (e.g., poly(styrene-r-benzocyclobutene-r- methyl methacrylate (PS-r-PMMA-r-BCB)). For example, such a random copolymer can comprise about 42% PMMA, about (58-x)% PS and x% (e.g., about 2-3%) of either polybenzocyclobutene or poly(para-azidomethylstyrene). An azidomethylstyrene-functionalized random copolymer can be UV photo-crosslinked (e.g., 1-5 MW/cm² exposure for about 15 seconds to about 30 minutes) or thermally crosslinked (e.g., at about 170°C for about 4 hours) to form a crosslinked polymer mat as a neutral wetting layer. A benzocyclobutene-functionalized random copolymer can be thermally cross-linked (e.g., at about 200°C for about 4 hours or at about 250°C for about 10 minutes).

[0042] In another embodiment, a neutral wetting random copolymer of polystyrene (PS), polymethacrylate (PMMA) with hydroxyl group(s) (e.g., 2-hydroxyethyl methacrylate (P(S-r-MMA-r-HEMA)) (e.g., about 58% PS) can be selectively grafted to a substrate **10** (e.g., an oxide) as a neutral wetting layer about 5-10 nm thick by heating at about 160°C for about 48 hours. See, for example, In et al., *Langmuir*, 2006, 22, 7855-7860.

[0043] In yet another embodiment, a blend of hydroxyl-terminated homopolymers and a corresponding low molecular weight block copolymer can be grafted (covalently bonded) to the substrate to form a neutral wetting interface layer (e.g., about 4-5 nm) for PS-b-PMMA and PS-b-P2VP, among other block copolymers. The block copolymer can function to emulsify the homopolymer blend before grafting. For example, an about 1 wt-% solution (e.g., in toluene) of a blend of about 20-50 wt-% (or about 30-40 wt-%) OH-terminated homopolymers (e.g., $M_n=6K$) and about 80-50 wt-% (or about 70-60 wt-%) of a low molecular weight block copolymer (e.g., 5K-5K) can be spin coated onto a substrate **10** (e.g., SiO_2), heated (baked) (e.g., at 160°C), and non-grafted (unbonded) polymer material removed, for example by a solvent rinse (e.g., toluene). For example, the neutral wetting material can be prepared from a blend of about 30 wt-% PS-OH ($M_n=6K$) and PMMA-OH ($M_n=6K$) (weight ratio of 4:6) and about 70 wt-% PS-b-PMMA (5K-5K), or a ternary blend of PS-OH (6K), P2VP-OH (6K) and PS-b-2PVP (8K-8K), etc.

[0044] Referring now to **FIGS. 5-5A**, a self-assembling, lamellar-phase block copolymer material **26** having an inherent pitch at or about L_o (or a ternary blend of block copolymer and homopolymers blended to have a pitch at or about L_B) is then deposited into the trenches **16**, typically as a film. A thin layer **26a** of the block copolymer material can be deposited onto the material layer **14** outside the trenches, e.g., on the mesas/spacers **18**.

[0045] In embodiments of the invention, the block copolymer material is combined with an ionic liquid.

[0046] The block copolymer or blend is constructed such that all of the polymer blocks will have equal preference for a chemically neutral wetting material on the trench floor during the anneal. Examples of diblock copolymers include, for example, poly(styrene)-b-poly(methylmethacrylate) (PS-b-PMMA) or other PS-b-poly(acrylate) or

PS-b-poly(methacrylate), poly(styrene)-b-poly(vinylpyridine) (PS-b-PVP), poly(styrene)-b-poly(ethylene oxide) (PS-b-PEO), poly(styrene)-b-poly(lactide) (PS-b-PLA), poly(styrene)-b-poly(tert-butyl acrylate) (PS-b-PtBA), and poly(styrene)-b-poly(ethylene-co-butylene (PS-b-(PS-co-PB)), poly(isoprene)-b-poly(methylmethacrylate) (PI-b-PMMA), and poly(isoprene)-b-poly(ethyleneoxide) (PI-b-PEO), among others, with PS-b-PMMA used in the illustrated embodiment. One of the polymer blocks of the block copolymer should be selectively and readily removable in order to fabricate an etch mask or template from the annealed film.

[0047] Another example of a diblock copolymer that can be utilized is a PS-b-PEO block copolymer having a cleavable junction such as a triphenylmethyl (trityl) ether linkage between PS and PEO blocks which would allow selective removal of the PEO domain under mild conditions. There are literature examples of the complexation of polar groups with potassium or lithium cations, but these elements constitute highly mobile contaminants for semiconductor devices. In some embodiments, a polar ionic liquid such as 1-ethyl-3-methylimidazolium trifluoromethanesulfonate in an effective concentration can be used for effective complexation with donor atoms in the block copolymer such as oxygen in PMMA or PEO, without the use of potential contaminants such as potassium or lithium.

[0048] A further example of a diblock copolymer that can be utilized is PS-b-PMMA block copolymer doped with PEO-coated gold nanoparticles of a size less than the diameter of the self-assembled cylinders (Park et al, *Macromolecules*, 2007, 40(11), 8119-8124).

[0049] Although diblock copolymers are used in the illustrative embodiment, other types of block copolymers (i.e., triblock or triblock or multiblock copolymers) can be used. Examples of triblock copolymers include ABC copolymers such as poly(styrene-b-methyl methacrylate-b-ethylene oxide) (PS-b-PMMA-b-PEO), and ABA copolymers such as PS-PMMA-PS, PMMA-PS-PMMA, and PS-b-PI-b-PS, among others.

[0050] The film morphology, including the domain sizes and periods (L) of the microphase-separated domains, can be controlled by chain length of a block copolymer (molecular weight, MW) and volume fraction of the AB blocks of a diblock copolymer to

produce the desired morphology (e.g., cylinders, lamellae, etc.). In embodiments in which a lamellar-forming diblock copolymer is used, the volume fractions of the two blocks (AB) are generally at a ratio between about 50:50 and 60:40 such that the diblock copolymer will microphase separate and self-assemble into alternating lamellar domains of polymer A and polymer B. An example of a lamellae-forming symmetric diblock copolymer is PS-*b*-PMMA ($L \sim 35$ nm) with a weight ratio of about 50:50 (PS:PMMA) and total molecular weight (M_n) of about 51 kg/mol to form 20 nm wide lamellae (e.g., width of about $0.5 * L$). To achieve an annealed film in which the lamellae are surface exposed, the *Chi* value of the polymer blocks (e.g., PS and PMMA) at a common annealing temperature is generally small such that the air interface is equally or non-selectively wetting to both blocks.

[0051] The L value of the block copolymer can be modified, for example, by adjusting the molecular weight of the block copolymer. The block copolymer material can also be formulated as a binary or ternary blend comprising a block copolymer and one or more homopolymers (HPs) of the same type of polymers as the polymer blocks in the block copolymer, to produce a blend that will swell the size of the polymer domains and increase the L value. The concentration of homopolymers in the blend can range from 0 to about 60 wt-%. An example of a ternary diblock copolymer blend is a PS-*b*-PMMA/PS/PMMA blend, for example, 60 wt-% of 46K/21K PS-*b*-PMMA, 20 wt-% of 20K polystyrene and 20 wt-% of 20K poly(methyl methacrylate). Another example is a blend of 60:20:20 (wt-%) of PS-*b*-PEO/PS/PEO, or a blend of about 85-90 wt-% PS-*b*-PEO and up to 10-15 wt-% PEO; it is believed that the added PEO homopolymer may function, at least in part, to lower the surface energy of the PEO domains to that of PS.

[0052] The block copolymer material is combined with a compatible ionic liquid (or blend of ionic liquids).

[0053] Ionic liquids are generally characterized non-aqueous, molten salt-like compounds that remain liquid below 100°C and are non-volatile with a negligible to extremely low vapor pressure. A distinguishing characteristic is the low temperature melting point of the compound. The melting point can be below room temperature or at a relatively low elevated temperature (for example 150°C) making the ionic liquid(s) compatible with polymeric films

while in their liquid state. Ionic liquids can be soluble in water, organic solvents, or both. Ionic liquids consist of a cation and an anion, and can be represented by the general formula B^+A^- where B^+ is a cation and A^- is an anion.

[0054] Embodiments of the invention utilize the intrinsic characteristics of ionic liquids, including liquid state at room temperature, very low volatility and/or a tunable range of solubility characteristics through particular cation/anion pairing, to fabricate films of ordered nanostructures that overcome existing limitations of some currently used additives to provide enhanced long range ordering of self-assembling polymer domains.

[0055] In embodiments of the invention, an ionic liquid is utilized that provides a surfactant effect and, as such, is structured to include a nonpolar component (e.g., alkyl chain) and a polar or water-soluble component to interact with both phases of the block copolymer material, similar to a conventional anionic or cationic surfactant. In other embodiments of the invention in which the desired effect is one of complexation of donor atoms in the polar block of a block copolymer, the cation (B^+) and anion (A^-) of the ionic liquid are based such that the final compound or molecule contains a cation that will complex selectively with a reactive (polar) group of one phase of the block copolymer material, for example, oxygen-containing functional groups of poly(ethylene oxide) (PEO) or poly(methylmethacrylate) (PMMA), or nitrogen-containing functional groups of poly(vinylpyridine) (PVP), for example. In some embodiments, the organic cation can be relatively small to provide increased interaction with the block copolymer material. In some embodiments, the ionic liquid is composed of an organic cation and a relatively smaller organic or inorganic anion.

[0056] Additionally, in embodiments of the method, the ionic liquid does not include elements such as sodium, potassium, or lithium, which can be contaminants in semiconductor processing.

[0057] Classes of organic cations (B^+) include mono-, di- and tri- substituted imidazoliums (e.g., 1-alkyl-3-methyl-imidazolium), pyridiniums (e.g., 1-alkylpyridinium), pyrrolidiniums (e.g., N-methyl-N-alkylpyrrolidinium, N-butyl-N-methylpyrrolidinium, N,N-dimethylpyrrolidinium), phosphoniums (e.g., tetraalkyl phosphonium, quaternary

phosphonium), ammoniums (e.g., tetraalkyl ammonium, quaternary ammonium, aromatic ammonium), guanidiniums, uroniums, isouroniums, thiouroniums, and sulfoniums (e.g., ternary sulphonium), among others.

[0058] Classes of anions (A⁻) include formate, sulfates (e.g., alkylsulfates, octylsulfates), sulfonates (e.g., methanesulfonates, trifluoromethanesulfonate, *p*-toluenesulfonate), amides, imides (e.g., bis(trifluoromethane)sulfonimide), methanes, borates (e.g., tetrafluoroborate, organoborates), phosphates (e.g., alkylphosphate, hexafluorophosphate, tris(pentafluoroethyl)trifluorophosphates or FAPs), glycolates, antimonates, cobalt tetracarbonyl, trifluoroacetate, and decanoate, among others. Although less desirable for semiconductor processes, halogens (e.g., chlorides, bromides, iodides) are another class of anions (A⁻). In some embodiments, the anion is a non-halogenated organic anion such as formate, an alkylsulfate, an alkylphosphate or glycolate, for example.

[0059] Ionic liquids are described, for example, in U.S. Patent No. 7,252,791 (Wasserscheid et al.), in U.S. Patent No. 6,998,152 (Uhlenbrock; Micron Technology, Inc.), in U.S. Patent No. 6,924,341 (Mays et al., UAB Research Foundation), and in U.S. Published Application 2006/0211871 (Dai et al.), among others. Non-limiting examples of ionic liquids include 1-ethyl-3-methyl-imidazolium ethylsulfate (Emim EtOSO₃), 1-ethyl-3-methyl-imidazolium bis(trifluoromethylsulfonyl) imide ([Emim][TFSI]), 1-ethyl-3-methyl-imidazolium tetrafluoroborate ([Emim][BF₄]), 1-butyl-3-methyl-imidazolium tetrafluoroborate ([Bmim][BF₄]), 1-butyl-3-methyl-imidazolium hexafluorophosphate ([Bmim][PF₆]), 1-butyl-3-methyl-imidazolium hydroxide ([Bmim]OH), 1-(2-hydroxyethyl)-3-methylimidazolium tetrafluoroborate ([HEmim][BF₄]), and tris-(2-hydroxyethyl)-methylammonium methylsulfate (MTEOA MeOSO₃), among others.

[0060] The ionic liquid (salt) can be dissolved, for example, in water or an organic solvent (e.g., methanol or acetone) and combined with the block copolymer material, which can be dissolved in an organic solvent such as toluene, benzene, toluene, xylene, dimethoxyethane, ethyl acetate, cyclohexanone, etc., or, although less desirable for some semiconductor processes, a halogenated solvent such as dichloromethane (CH₂Cl₂), dichloroethane (CH₂Cl₂), chloroform, methylene chloride, a chloroform/octane mixture, etc.

[0061] The block copolymer material can also be combined with a mixture or blend of two or more compatible ionic liquids.

[0062] In some embodiments, the ionic liquid/block polymer composition or blend can include water in an amount effective to improve coordination or hydrogen-bonding during casting and promote a more rapid or longer-range ordering in the self-assembly of the polymer domains during the anneal, for example, about 0.1-10 % by wt of water, based on the total weight of the composition.

[0063] The structure of both the block copolymer and the ionic liquid can be tailored to meet the length scale, orientation, organizational and functional requirements of the application. The concentration of the ionic liquid in the block copolymer material can vary and in embodiments of the method, is about 0.1-50 % by wt, or about 20-50% by wt, with the balance as the block copolymer. In some embodiments, the ratio of block copolymer-to-ionic liquid (e.g., as % by wt) is according to the number of reactive atoms (e.g., oxygen atoms and/or nitrogen atoms) of the selected domain (e.g., PEO) of the block copolymer that are available for selective coordination or complexation with the cation molecule (B^+) of the ionic liquid, e.g., the molar ratio of the oxygen in PEO to the cation (B^+) of the ionic liquid, or monomer-to-ionic liquid ratio ($[O]/[K]$, e.g., 64). In other embodiments, the ionic liquid can be included at a relatively high amount, e.g., about 1-50 % by wt, to provide both complexation and a surfactant effective amount to enhance chain mobility and promote self-assembly of the polymer domains during the anneal.

[0064] In some embodiments, one of the polymer blocks (e.g., the minor domain) can be selectively doped or structured to incorporate an inorganic component or species (e.g., a filler component) during annealing, which does not interfere with the ionic liquid functionality, and will remain on the substrate as an etch resistant material (e.g., mask) upon selective removal of the other polymer domain (e.g., the major domain) or, in some embodiments, removal of both the majority and minority polymer domains. Block copolymers that incorporate an inorganic species can be prepared by techniques known in the art, for

example, by a direct synthesis technique, or by incorporating atoms of an inorganic species by complexation or coordination with a reactive group of one of the polymer blocks.

[0065] For example, the block copolymer can be blended with an inorganic heat resistant material or precursor thereof, which that has a high affinity to one of the polymer chains of the block copolymer and will segregate with the polymer phase during the anneal, for example, a metal salt, an organic metal salt (e.g., lithium 2,4-pentanedionate, ruthenium 2,4-pentanedionate, etc.), a metal oxide gel, metal alkoxide polymers (e.g., alkoxysilanes and alkylalkoxysilanes), metal oxide precursor (e.g., polysilsesquioxane), metal nitride precursor, and metal fine particles. Examples of metals include silicon (Si), chromium (Cr), titanium (Ti), aluminum (Al), molybdenum (Mo), gold (Au), platinum (Pt), ruthenium (Ru), zirconium (Zr), tungsten (W), vanadium (V), lead (Pb), and zinc (Zn), among others. See, for example, US 2007/0222995 and US 2007/0289943 (Lu; Agilent Technologies Inc.), and USP 6,565,763 (Asakawa et al.).

[0066] Block copolymers that incorporate an inorganic species can also be prepared by a direct synthesis technique, for example, as described in US 2007/0222995. For example, a sequential living polymerization of a nonmetal-containing monomer (e.g., styrene monomer) followed by an inorganic species-containing monomer (e.g., ferrocenylethylmethylsilane monomer) can be used to synthesize an inorganic species-containing block copolymer (e.g., poly(styrene)-b-poly(ferrocenylmethylsilane) (PS-b-PFEMS).

[0067] Examples of diblock copolymers that incorporate an inorganic species include poly(styrene)-b-poly(dimethylsiloxane) (PS-b-PDMS), poly(isoprene)-b-poly(dimethylsiloxane) (PI-b-PDMS), PS-b-PFEMS, poly(isoprene)-b-poly(ferrocenylmethylsilane) (PI-b-PFEMS), poly(styrene)-b-poly(vinylmethylsiloxane) (PS-b-PVMS), poly(styrene)-b-poly(butadiene) (PS-b-PB) where the polybutadiene (PB) is stained by osmium tetroxide (OSO_4), and poly(styrene)-b-poly(vinylpyridine) (PS-b-PVP) where the pyridine group forms a coordination bond with an inorganic species, among others.

[0068] After annealing and self assembly of the polymer blocks into the perpendicular-oriented lamellae, an oxidation process (e.g., ultraviolet (UV)-ozonation or oxygen plasma

etching) can be performed to remove the organic components of one or both of the polymer domains and convert the inorganic species to form a non-volatile inorganic oxide, which remains on the substrate and can be used as a mask in a subsequent etch process. For example, the inorganic species of the PDMS and PFEM block copolymers are silicon and iron, which, upon oxidation, will form non-volatile oxides, e.g., silicon oxide (SiO_x) and iron oxide (Fe_xO_y).

[0069] Referring now to FIGS. 5-5A, the lamellar-phase block copolymer material 26 can be cast or deposited into the trenches 16 to a thickness (t) at or about the inherent pitch or L value of the block copolymer material (e.g., about $\pm 20\%$ of L). The block copolymer material can be deposited by spin casting (spin-coating) from a dilute solution (e.g., about 0.25-2 wt% solution) of the copolymer in a suitable organic solvent such as dichloroethane (CH_2Cl_2) or toluene, for example. Capillary forces pull excess block copolymer material (e.g., greater than a monolayer) into the trenches 16. The thickness of the block copolymer material 26 can be measured, for example, by ellipsometry techniques. As shown, a thin layer or film 26a of the block copolymer material can be deposited and remain on the material layer 14 outside the trenches, e.g., on the spacers 18. Upon annealing, the thin film 26a will flow into the trenches leaving a structureless brush layer on the material layer 14 from a top-down perspective.

[0070] An annealing process is then conducted (arrows \downarrow , FIG. 6A) to cause the polymer blocks to phase separate in response to the preferential and neutral wetting of the trench surfaces and form a self-assembled polymer material 28, as illustrated in FIGS. 6-6A.

[0071] In embodiments of the method of the invention, the polymer material 26 is annealed by thermal annealing, which can be conducted at above the glass transition temperature (T_g) of the component blocks of the copolymer material. For example, a PS-b-PMMA copolymer material can be annealed at a temperature of about 180-230°C in a vacuum oven for about 1-24 hours to achieve the self-assembled morphology. The resulting morphology of the annealed copolymer material 28 (e.g., perpendicular oriented lamellae 30, 32) can be examined, for example, using atomic force microscopy (AFM), transmission electron microscopy (TEM), scanning electron microscopy (SEM).

[0072] The block copolymer material can be globally heated or, in other embodiments, a zone or localized thermal anneal can be applied to portions or sections of the block copolymer material. For example, the substrate can be moved across a hot-to-cold temperature gradient positioned above or underneath the substrate (or the thermal source can be moved relative to the substrate) such that the block copolymer material self-assembles upon cooling after passing through the heat source. Only those portions of the block copolymer material that are heated above the glass transition temperature of the component polymer blocks will self-assemble, and areas of the material that were not sufficiently heated remain disordered and unassembled. "Pulling" the heated zone across the substrate can result in faster processing and better ordered structures relative to a global thermal anneal.

[0073] In some embodiments, the block copolymer material 26 (e.g., PS-b-PEO) is solvent annealed to form the self-assembled polymer material 28. Solvent annealing generally consists of two phases. In a first phase, the BCP material is exposed to a solvent vapor that acts to plasticize the film and increase chain mobility causing the domains to intermingle and the loss of order inherent from casting the polymer material. The organic solvent that is utilized is based at least in part on its solubility in the block copolymer material such that sufficient solvent molecules enter the block copolymer material to promote the order-disorder transition of the polymer domains and enable the required molecular rearrangement. Examples of solvents include aromatic solvents such as benzene, toluene, xylene, dimethoxyethane, ethyl acetate, cyclohexanone, etc., and chlorinated solvents such as chloroform, methylene chloride, a chloroform/octane mixture, etc., among others. In a second phase, the substrate 10 is removed from the solvent vapor and the solvent and solvent vapors are allowed to slowly diffuse out of the polymer material and evaporate. The block copolymer material begins to "dry" as the solvent evaporates from the material. The evaporation of the solvent is highly directional and forms a solvent concentration gradient extending from the "top" (surface) of the BCP material to the "bottom" of the BCP material at the trench floor 24 that induces orientation and self-assembly of structures starting at the air-surface interface and driven downward to the floor 24 of the trench 16, with formation of perpendicular-oriented lamellar domains 30, 32 guided by the trench sidewalls 20 and extending completely from the air interface to the trench floor 24.

[0074] The use of a partly- or near-saturated solvent vapor phase above the block copolymer material provides a neutral wetting interface. The concentration of solvent in the air immediate at the vapor interface with the surface of the BCP material is maintained at or under saturation as the solvent evaporates from the BCP material to maintain a neutral wetting interface such that both (or all) polymer blocks will equally wet the vapor interface and, as the solvent evaporates, will phase separate. When the concentration of solvent in the BCP material at the air interface becomes low enough, the BCP loses plasticity and the phase-separated domains at the air interface become "locked in." As the solvent concentration decreases downwardly through the BCP material, the domains formed at the air interface "seed" or drive the self-assembly downward such that the domains orient perpendicular to the substrate **10** and the lamellar features extend completely from the air interface to the trench floor **24**.

[0075] In response to the wetting properties of the trench surfaces **20**, **22**, **24**, upon annealing, the lamellar-phase block copolymer **26** will form a self-assembled polymer layer **28** composed of a single layer of perpendicular-oriented lamellar domains **30**, **32** having a width (w_d) of about $0.5 * L$ (e.g., 5-50 nm, or about 20 nm, for example), which extend the length and span the width of the trenches **16**. A preferred block (e.g., PMMA domain) of the block copolymer material will segregate to the sidewalls **20** and ends **22** of the trench **16** to form a thin interface brush or wetting layer **32a**, with the thickness of the wetting layer **32a** being generally about one-fourth of the L value. Entropic forces drive the wetting of a neutral wetting surface (e.g., floor **24**) by both blocks, and enthalpic forces drive the wetting of a preferential-wetting surface (e.g., sidewalls **20**, ends **22**) by the preferred block (e.g., the minority block).

[0076] In addition, the selective interaction and complexation of the cation (B^+) of the ionic liquid (salt) with reactive groups of one of the polymer blocks (e.g., O-containing groups of PMMA or PEO, etc.) enhances and/or induces perpendicular orientation of the polymer domains upon annealing, and helps control and improve the long range ordering of the lamellar domains **30**, **32** (e.g., PS, PMMA) of the polymer material (e.g., PS-b-PMMA) within the trenches, and/or decreases the number of pattern errors (e.g., disclinations, etc.) in the self-assembled pattern.

[0077] In embodiments in which the block copolymer material 26 includes an inorganic species such as a metal (e.g., Si, Fe, etc.), the inorganic species will segregate to one polymer phase upon annealing.

[0078] Generally, a block copolymer thin film 26a outside the trenches (e.g., on mesas/spacers 18) will not be thick enough to result in self-assembly. Optionally, the unstructured thin film 26a can be removed, for example, by an etch technique or a planarization process.

[0079] Optionally, the copolymer material can be treated to crosslink one of the polymer domains to fix and enhance the strength of the polymer blocks. For example, one of the polymer blocks (e.g., the PS domains) can be structured to inherently crosslink (e.g., upon exposure to ultraviolet (UV) radiation, including deep ultraviolet (DUV) radiation), or the polymer block can be formulated to contain a crosslinking agent. For example, the trench regions can be selectively exposed through a reticle (not shown) to crosslink only the self-assembled polymer material 28 within the trenches 16 and a wash can then be applied with an appropriate solvent (e.g., toluene) to remove the non-crosslinked portions of the block copolymer material 26a, leaving the registered self-assembled polymer material 28 within the trench and exposing the surface of the material layer 14 above/outside the trenches. In another embodiment, the annealed polymer material 28 can be crosslinked globally, a photoresist material can be applied to pattern and expose the areas of the polymer material 26a outside the trench regions, and the exposed portions of the polymer material 26a can be removed, for example by an oxygen (O₂) plasma treatment.

[0080] An embodiment of the use of the self-assembled polymer material 28 as an etch mask is illustrated in FIGS. 7-7A. As depicted, one of the lamellar domains 32 can be selectively removed to form a structure 34 composed of line openings (slits) 36 separated by the remaining lamellar domain 30, which can then be used as a mask to etch the underlying substrate 10.

[0081] For example, in using a PS-b-PMMA block copolymer, PMMA domains 32 can be selectively removed, for example, by UV exposure/acetic acid development.

[0082] Removal of water-soluble PEO phase domains **32** can be performed, for example, by exposure of the self-assembled block copolymer material **28** (optionally cross-linked) to aqueous hydroiodic acid or exposure to water alone, which will draw PEO to the surface without cleaving the bonds to the PS domains. In embodiments in which the PS-b-PEO block copolymer includes an acid-cleavable linker (e.g., trityl alcohol linker) positioned between the polymer blocks, exposure of the (crosslinked) self-assembled polymer material **28** to an aqueous acid (e.g., trifluoroacetic acid) or to an acid vapor can be performed to cleave the polymer into PEO and PS fragments (S. Yurt et al., "Scission of Diblock Copolymers into Their Constituent Blocks," *Macromolecules* 2006, 39, 1670-1672). Rinsing with water can then be performed to remove the cleaved PEO domains **32**. In other embodiments, exposure to water to draw the PEO domains to the surface followed by a brief oxygen (O₂) plasma etch can also be performed to remove the PEO domains.

[0083] In some embodiments, the resulting films have a corrugated surface that defines a linear pattern of fine, nanometer-scale, parallel slits (openings) **36** about 5-50 nm wide and several microns in length (e.g., about 10-4000 μm), the individual slits separated by a polymer matrix **30** about 5-50 nm wide. For example, removal of the PMMA domains affords a PS mask of sublithographic dimensions, for example, a pitch of about 35 nm (17.5 nm PS domain). A smaller pitch can be dialed in by using lower molecular weight diblock copolymers.

[0084] The remaining polymer domains **30** (e.g., PS) can then be used as a lithographic template or mask to etch (arrows ↓) the underlying substrate **10** at the trench floor **24** to form a series of channels or trenches **38** (shown in phantom), e.g., using a selective reactive ion etch (RIE), or other process.

[0085] As depicted in FIGS. 8-8A, the residual polymer matrix **30** can be removed, e.g., by a UV-ozonation or oxygen plasma etch to remove organic material, and the line openings **38** in the substrate **10** can be filled with a material **40** such as a metal or metal alloy such as Cu, Al, W, Si, and Ti₃N₄, among others, to form arrays of conductive line, or with an insulating (dielectric) material such as SiO₂, Al₂O₃, HfO₂, ZrO₂, SrTiO₃, and the like. Further processing can then be performed as desired.

[0086] In embodiments of the invention in which one of the polymer domains includes an inorganic species (e.g., Si, Fe, etc.), an oxidation process such as a UV-ozone or oxygen plasma etching, can be performed to remove the organic material (i.e., the polymer domains) and convert the inorganic species to a non-volatile inorganic oxide, e.g., silicon oxide (SiO_x), iron oxide (Fe_xO_y), etc., which remains on the substrate and can be used as a mask in a subsequent etch process. For example, a block copolymer material **26** such as PS-b-PMMA combined (e.g., doped) with a Si- and/or Fe-containing additive, and the Si and/or Fe species are segregated to the PMMA domains **32** and wetting layer **32a** (FIGS. 6-6A). Referring to FIGS. 9-9A, an oxidation process (arrows \downarrow) can be performed to remove both the PS and PMMA lamellae (**30**, **32**) and convert the Si and/or Fe species within the PMMA lamellae to inorganic oxide, e.g., SiO_x and/or Fe_xO_y , resulting in non-volatile, inorganic oxide lines **32b'** on the substrate **10'**. The oxide lines **32b'** can then be used as a mask to etch line openings **38'** (e.g., trenches) (shown in phantom) in the substrate **10'**, e.g., using an anisotropic selective reactive ion etch (RIE) process. The residual oxide lines **32b'** can then be removed, for example, using a fluoride-based etchant, and the substrate openings **38'** can be filled with a desired material (**40**), similar to FIGS. 8-8A.

[0087] The films provide linear arrays having long range ordering and registration for a wide field of coverage for templating a substrate. The films are useful as etch masks for producing close pitched nanoscale channel and grooves that are several microns in length, for producing features such as floating gates for NAND flash with nanoscale dimensions. By comparison, photolithography techniques are unable to produce channels much below 60 nm wide without high expense. Resolution can exceed other techniques such as conventional photolithography, while fabrication costs utilizing methods of the disclosure are far less than electron beam (E-beam) or EUV photolithographies which have comparable resolution.

[0088] A method for fabricating a self-assembled block copolymer material that defines a one-dimensional (1-D) array of nanometer-scale, perpendicular-oriented cylinders according to an embodiment of the invention is illustrated in FIGS. 10-12. The method involves an anneal of a cylindrical-phase, block copolymer material formulated with an ionic liquid in combination with graphoepitaxy to form a 1-D array of perpendicular-oriented cylinders in a row within a polymer matrix.

[0089] As depicted in FIGS. 10-10B, a substrate 10'' is provided, which can be silicon, silicon oxide, silicon nitride, silicon oxynitride, silicon oxycarbide, among other materials. As further depicted, an array of conductive lines 42'' (or other active area, e.g., semiconducting regions) are situated within the substrate 10'', which in the illustrated embodiment, have a center-to-center distance (or pitch, p_L) at or about the L value of the block copolymer material.

[0090] In the illustrated embodiment, a neutral wetting material 12'' (e.g., random copolymer) has been formed over the substrate 10'', as previously described, and a material layer 14'' formed over the neutral wetting material and etched to form trenches 16'', with mesas/spacers 18'' outside and between the trenches.

[0091] A single trench or multiple trenches (as shown) can be formed in the material layer and span the entire width of an array of lines (or other active area). In the present embodiment, the trenches 16'' are formed over the active areas 42'' (e.g., lines) such that when the cylindrical-phase block copolymer material within the trench is annealed, each cylinder will be situated above and aligned with a single active area 42'' (e.g., conductive line). In some embodiments, multiple trenches are formed with the ends 22'' of each adjacent trench 16'' aligned or slightly offset from each other at less than 5% of L such that cylinders of adjacent trenches are aligned and situated above the same line 42''.

[0092] As previously described with reference to the embodiment using a lamellar-phase block copolymer material, the trench sidewalls 20'' and ends 22'' are preferential wetting to a preferred block (e.g., PMMA) of the block copolymer material, and the trench floors 24'' are neutral wetting. For example, the material layer 14'' can be formed from a material that is inherently preferential wetting to the PMMA block, e.g., oxide (e.g., silicon oxide, SiO_x), silicon (with native oxide), silicon nitride, etc., and a neutral wetting material 12'' can be provided by a neutral wetting random copolymer (e.g., PS-*r*-PMMA) over the substrate 10'' and exposed at the trench floor 24''.

[0093] There is a shift from two rows to one row of the perpendicular cylinders within the center of the trench as the width (w_t) of the trench is decreased and/or the periodicity (L value) of the block copolymer is increased, for example, by forming a ternary blend by the

addition of both constituent homopolymers. For example, a block copolymer or blend having a pitch or L value of 35-nm deposited into a 75-nm wide trench having a neutral wetting floor will, upon annealing, result in about 17.5-nm diameter ($0.5*L$) perpendicular cylinders that are offset by about one-half the pitch distance (or about $0.5*L$) in a zigzag pattern for the length (l_t) of the trench, rather than perpendicular cylinders aligned with the sidewalls in a single line row down the center of the trench.

[0094] In the present embodiment, the trenches 16'' are structured with a width (w_t) of about $1.5-2*L$ (or $1.5-2$ X the pitch value) of the block copolymer such that a cylindrical-phase block copolymer (or blend) of about L that is cast into the trench to a thickness of about the inherent L value of the block copolymer material will self assemble into a single row of perpendicular-oriented cylinders with a diameter at or about $0.5*L$ and a center-to-center distance (p) of adjacent cylinders at or about L . In using a cylindrical-phase block copolymer with an about 50 nm pitch value or L , for example, the width (w_t) of the trenches 16 can be about $1.5-2*50$ nm or about 75-100 nm to result in a single row of perpendicular-oriented cylinders (diameter $\simeq 0.5*L$ or about 25 nm) aligned with the sidewalls down the center of the trench. The length (l_t) of the trenches is at or about nL or an integer multiple of L , typically within a range of about $n*10$ to about $n*100$ nm (with n being the number of cylinders).

[0095] A diblock copolymer with volume fractions at ratios of the two blocks generally between about 60:40 and 80:20 (i.e., the major block polymer A volume fraction in the range of 0.6 to 0.8), will microphase separate and self-assemble into periodic cylindrical domains of polymer B within a matrix of polymer A. An example of a cylinder-forming PS-*b*-PMMA copolymer material ($L_o \sim 35$ nm) to form about 20 nm diameter cylindrical PMMA domains in a matrix of PS is composed of about 70 wt-% PS and 30 wt-% PMMA with a total molecular weight (M_n) of 67 kg/mol. An example of a cylinder-forming PS-*b*-PVP copolymer material ($L_o \sim 28$ nm) to form about 20 nm wide half-cylindrical PVP domains in a matrix of PS is composed of about 70 wt-% PS and 30 wt-% PVP with a total molecular weight (M_n) of 44.5 kg/mol. As another example, a PS-*b*-PLA copolymer material ($L = 49$ nm) can be composed of about 71 wt-% PS and 29 wt-% PLA with a total molecular weight (M_n) of about 60.5 kg/mol to form about 27 nm diameter cylindrical PLA domains in a matrix of PS.

[0096] Referring now to FIGS. 11-11B, a cylindrical-phase block copolymer material 26'' (or blend) having an inherent pitch at or about L is deposited into the trenches 16'' to a thickness (t_i) at or about L (e.g., about $\pm 20\%$ of the L value), typically about 10-100 nm, and annealed (e.g., by thermal anneal). The block copolymer material 26'' can be composed of any of the block copolymers (e.g., PS-*b*-PMMA, PS-*b*-PEO, PS-*b*-PLA, etc.) combined with an ionic liquid, as previously described. The block copolymer material 26'' can then be thermal or solvent annealed as previously described.

[0097] As depicted in FIGS. 12-12B, upon annealing and in response to the wetting properties of the trench surfaces, the cylindrical-phase block copolymer material 26'' will self-assemble into a polymer material 28'' (e.g. film) composed of perpendicular-oriented cylindrical domains 32'' of the minority (preferred) polymer block (e.g., PMMA) within a polymer matrix 30'' of the majority polymer block (e.g., PS).

[0098] The constraints provided by the width (w_i) of the trench 16'' and the character of the block copolymer composition (e.g., PS-*b*-PMMA having an inherent pitch at or about L) combined with a trench floor 24'' that exhibits neutral or non-preferential wetting toward both polymer blocks (e.g., a random graft copolymer) and sidewalls 20'' that are preferential wetting by the preferred (minority) polymer block, results in a 1-D array of cylindrical domains 30'' of the minority polymer block (e.g., PMMA) within a matrix 30'' of the majority polymer block (e.g., PS), with the cylindrical domains 32'' oriented perpendicular to the trench floors 24'' in a single row aligned parallel to the sidewalls 20'' for the length of the trench. The diameter of the cylinders 32'' will generally be about one-half of the center-to-center distance between cylinders or about $0.5 * L$ (e.g., 5-50 nm, or about 20 nm, for example). The preferred (minority) block (e.g., PMMA) will also segregate to the sidewalls 20'' and ends 22'' of the trench to form a thin brush interface or wetting layer 32a'' having a thickness that is generally about one-fourth of the center-to-center distance between adjacent cylinders 34. For example, a layer of PMMA domains will preferentially wet oxide interfaces, with attached PS domains consequently directed away from the oxide material. In some embodiments, the self-assembled block copolymer material 28'' is defined by an array of cylindrical domains (cylinders) 32'', each with a diameter at or about $0.5 * L$, with the

number (n) of cylinders in the row according to the length of the trench, and the center-to-center distance (pitch distance, p) between each cylinder at or about L .

[0099] Polymer segments (e.g., the PS matrix 30") of the annealed polymer material 28" can be optionally be crosslinked, and any unstructured polymer material 26a" on surfaces outside the trenches can then be optionally removed, as depicted in FIGS. 11-11B.

[00100] The self-assembled polymer material 28" can then be processed, for example, to form an etch mask 34" to form cylindrical openings in the substrate 10". For example, as illustrated in FIGS. 13-13B, the cylindrical polymer domains 32" (e.g., PMMA) of the self-assembled polymer material 28" can be selectively removed resulting in a porous polymer matrix 30" (e.g., of PS) with openings 36" exposing the trench floor 24". The remaining polymer matrix 36" (e.g. PS) can be used as a mask to etch (arrows ↓) a series of openings or contact holes 38" (shown in phantom) to the conductive lines 42" or other active areas (e.g., semiconducting regions, etc.) in the underlying substrate 10" (or an underlayer), for example, using a selective reactive ion etching (RIE) process.

[00101] As depicted in FIGS. 14-14B, the remnants of the etch mask 34" (e.g., matrix 30") can then be removed and the cylindrical openings 38" can be filled with a desired material 40" such as a metal or metal alloy such as Cu, Al, W, Si, and Ti_3N_4 , among others, to form arrays of cylindrical contacts to the conductive lines 42". The cylindrical openings 38" in the substrate can also be filled with a metal-insulator-metal stack to form capacitors with an insulating material such as SiO_2 , Al_2O_3 , HfO_2 , ZrO_2 , $SrTiO_3$, and the like.

[00102] Methods of the disclosure provide a means of generating self-assembled diblock copolymer films composed of perpendicular-oriented cylinders in a polymer matrix. The methods provide ordered and registered elements on a nanometer scale that can be prepared more inexpensively than by electron beam lithography, EUV photolithography or conventional photolithography. The feature sizes produced and accessible by this invention cannot be easily prepared by conventional photolithography. The described methods and systems can be readily employed and incorporated into existing semiconductor manufacturing process flows and provide a low cost, high-throughput technique for fabricating small structures.

[00103] In particular, the mixing and combination of the block copolymer material with one or more ionic liquids according to embodiments of the invention, can enhance or improve the long range ordering of the polymer domains (e.g., lamellae and cylinders) through coordination or other interaction with one phase of the block copolymer without the introduction of highly mobile contaminants such as sodium (Na), lithium (Li) or potassium (K).

[00104] Although specific embodiments have been illustrated and described herein, it will be appreciated by those of ordinary skill in the art that any arrangement which is calculated to achieve the same purpose may be substituted for the specific embodiments shown. This application is intended to cover any adaptations or variations that operate according to the principles of the invention as described. Therefore, it is intended that this invention be limited only by the claims and the equivalents thereof. The disclosures of patents, references and publications cited in the application are incorporated by reference herein.

WHAT IS CLAIMED IS:

1. A method of forming a nanostructured polymer material on a substrate, comprising:
forming a self-assembling lamellar-phase block copolymer composition within a trench in a material layer on the substrate, the trench having a length, a neutral wetting floor, and opposing sidewalls and ends that are preferentially wetting to a first block of the block copolymer, and the block copolymer composition comprising a blend of a block copolymer and an ionic liquid; and
annealing the block copolymer material such that said block copolymer material self-assembles into alternating lamellar domains of the first block and a second block of the block copolymer oriented perpendicular to the trench floor and extending the length of the trench.
2. The method of Claim 1, wherein the block copolymer composition comprises about 0.1-50 % by wt of the ionic liquid, with the balance as the block copolymer.
3. The method of Claim 1, wherein the ionic liquid comprises an organic cation selected from the group consisting of substituted imidazoliums, pyridiniums, pyrrolidiniums, phosphoniums, ammoniums, guanidiniums, uroniums, isouroniums, thiouroniums, and sulfoniums.
4. The method of Claim 1, wherein the ionic liquid comprises an anion selected from the group consisting of halogens, formate, sulfates, sulfonates, amides, imides, methanes, borates, phosphates, glycolates, antimonates, cobalt tetracarbonyl, trifluoroacetate, decanoate, alkylsulfate, alkylphosphate, and glycolate.
5. The method of Claim 2, wherein the block copolymer composition further comprises about 0.1-10 % by wt water.
6. The method of Claim 1, wherein the block copolymer comprises polystyrene and at least one of poly(methyl methacrylate), poly(ethylene oxide) and poly(vinylpyridine).
7. A method of forming a nanostructured polymer material on a substrate, comprising:

forming a self-assembling cylindrical-phase block copolymer composition within a trench in a material layer on the substrate, the block copolymer composition comprising a blend of a block copolymer and an ionic liquid; the trench having a length, a neutral wetting floor, and opposing sidewalls and ends that are preferentially wetting to a minority block of the block copolymer, and; and

annealing the block copolymer composition such that said block copolymer self-assembles into cylindrical domains of a first block within a matrix of a second block of the block copolymer, said self-assembled block copolymer material having a thickness, and the cylindrical polymer domains oriented perpendicular to the trench floor and extending through said thickness of the self-assembled block copolymer material in a single row for the length of the trench.

8. The method of Claim 7, wherein the trench has a width of about $1.5-2 \times L$.

9. A method of etching a substrate, comprising:

annealing a lamellar-phase block copolymer material situated in a trench in a material layer overlying the substrate, the trench having opposing sidewalls and ends that are preferentially wetting to a one block of the block copolymer, a floor that is neutral wetting, a width and a length; the block copolymer material blended with an ionic liquid; wherein the block copolymer material forms perpendicular-oriented lamellae spanning the width and extending the length of the trench;

selectively removing one of the polymer blocks to form openings exposing the substrate; and

etching exposed portions of the substrate to form openings therein.

10. The method of Claim 9, further comprising, prior to removing the polymer blocks, selectively crosslinking another of the polymer blocks.

11. The method of Claim 9, wherein said etching forms a pattern of parallel trenches within the trench.

12. The method of Claim 11, further comprising filling the trenches in the substrate with a fill material.

13. The method of Claim 9, wherein one block of the block copolymer composition comprises a metal selected from the group consisting of silicon, chromium, titanium, aluminum, molybdenum, gold, platinum, ruthenium, zirconium, tungsten, vanadium, lead, and zinc.

14. The method of Claim 9, wherein the minority block of the block copolymer comprises a metal component, and selectively removing the polymer blocks further comprises forming the metal component into an inorganic metal material such that said inorganic metal material forms a plurality of lines on the substrate.

15. A method of etching a substrate, comprising:

annealing a cylindrical-phase block copolymer material situated in a trench in a material layer overlying the substrate, the trench having opposing sidewalls and ends that are preferentially wetting to a minority block of the block copolymer, a floor that is neutral wetting, a width and a length; the block copolymer material blended with an ionic liquid; wherein the block copolymer material forms a single array of perpendicular-oriented cylinders of a minority polymer block in a matrix of a majority polymer block, said annealed block copolymer material having a thickness, and the cylinders extending through said thickness of the annealed block copolymer material;

selectively removing the minority polymer block to form openings exposing the substrate; and

etching exposed portions of the substrate to form cylindrical openings therein.

16. The method of Claim 15, further comprising, prior to removing the minority polymer block, selectively crosslinking the majority polymer block.

17. The method of Claim 15, further comprising filling the openings in the substrate with a fill material.

18. The method of Claim 17, wherein the fill material comprises a metal, a metal alloy, and a metal/insulator/metal stack.

19. A method of etching a substrate, comprising:

forming a block copolymer material within a trench in a material layer overlying the substrate, the trench having opposing sidewalls and ends that are preferentially wetting to a

one polymer block of the block copolymer, a neutral wetting floor, a width and a length; the block copolymer material blended with an ionic liquid;

causing a microphase separation in the block copolymer material to form a polymer layer comprising self-assembled polymer domains oriented perpendicular to the floor of the trench and aligned parallel to the sidewalls for the length of the trench;

selectively crosslinking one of the polymer domains;

selectively removing non-crosslinked polymer domains to form openings through the polymer layer; and

etching the substrate through the openings in the polymer layer.

20. The method of Claim 19, wherein the block copolymer material comprises a lamellar-phase block copolymer material that microphase separates into alternating polymer domains of perpendicular-oriented lamellae.

21. The method of Claim 19, wherein the block copolymer material comprises a cylindrical-phase block copolymer material that microphase separates into perpendicular-oriented cylindrical domains of a minority polymer block within a matrix of a majority polymer block.

22. A polymeric material situated within a trench in a material layer overlying a substrate, the trench having sidewalls, ends, a floor, a width and a length, the polymeric material comprising a self-assembled block copolymer material comprising alternating lamellae of a first polymer block selectively coordinating an ionic liquid and a second polymer block, the lamella oriented perpendicular to the trench floor and extending the length of the trench.

23. A polymeric material situated within a trench in a material layer overlying a substrate, the trench having sidewalls, ends, a floor, a width and a length, the polymeric material comprising a self-assembled block copolymer material comprising cylindrical polymer domains of a minority polymer block selectively coordinating an ionic liquid in a matrix of a majority polymer block, the cylindrical polymer domains oriented perpendicular to the trench floor and in a single array extending the length of the trench.

1/16

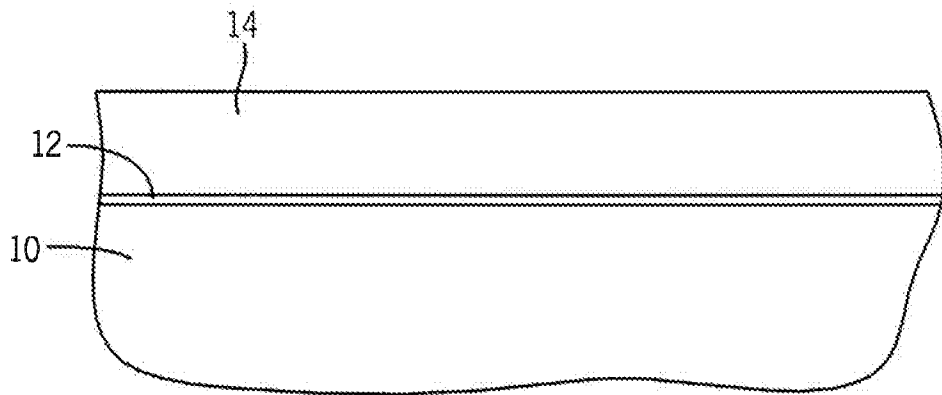
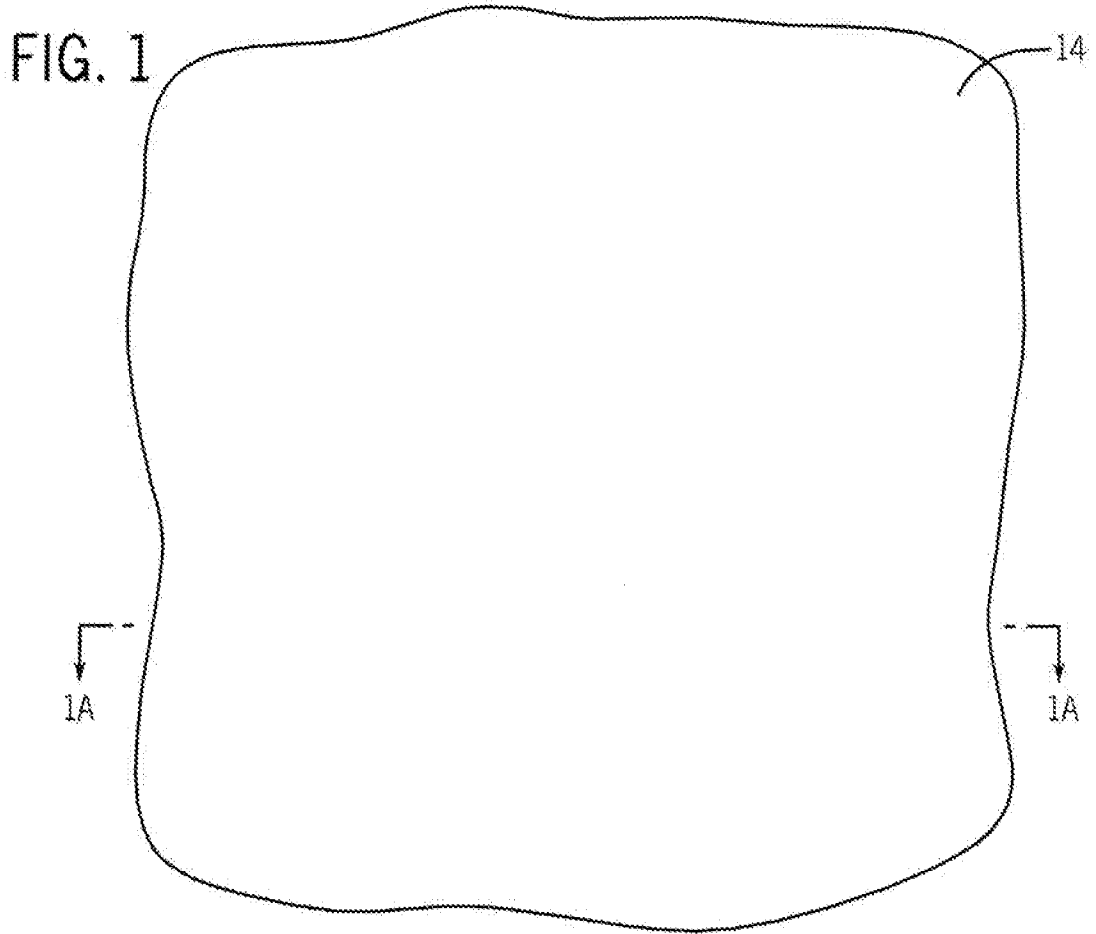

FIG. 1A

2 / 16

FIG. 2

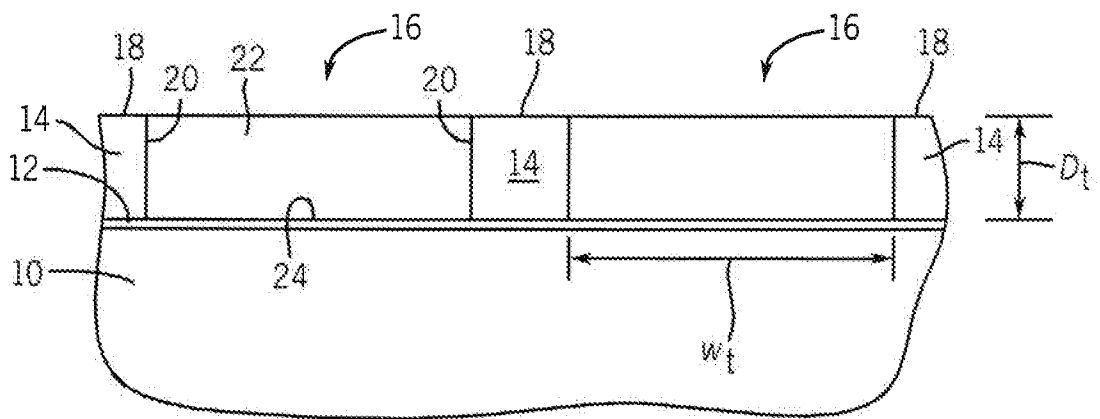
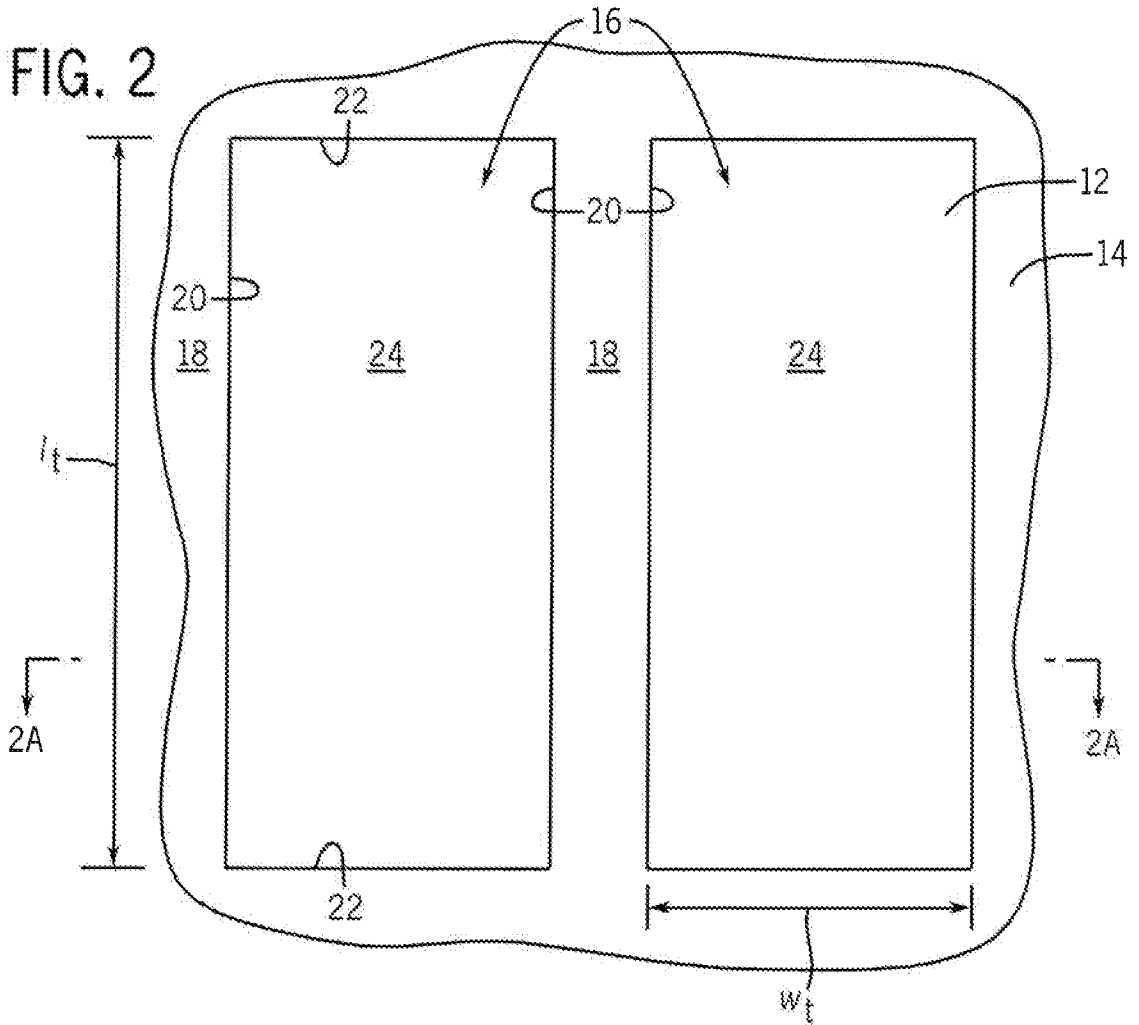

FIG. 2A

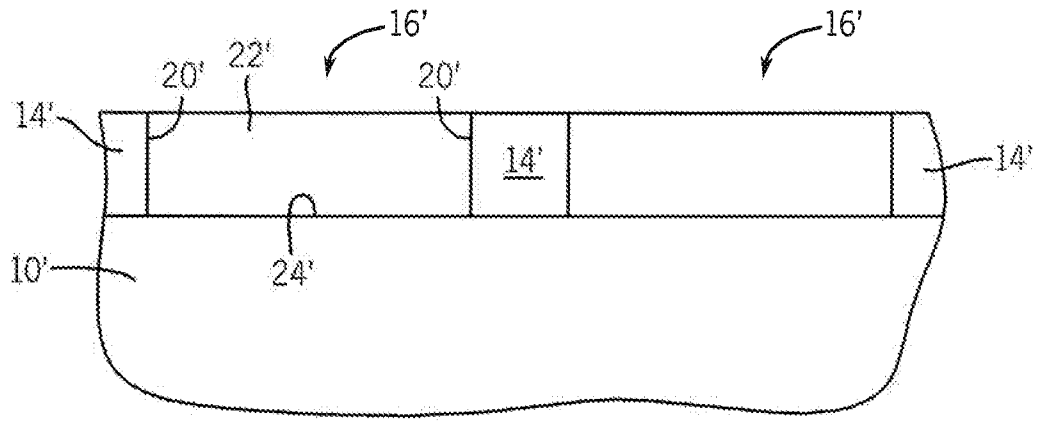

FIG. 3

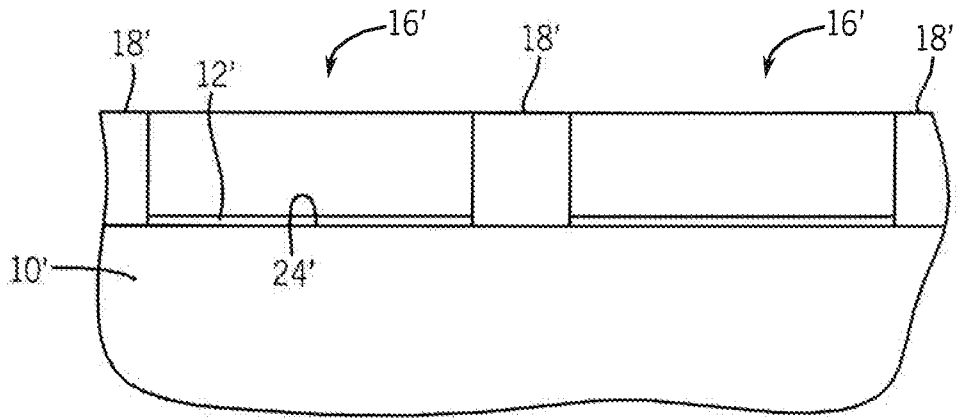

FIG. 4

FIG. 5

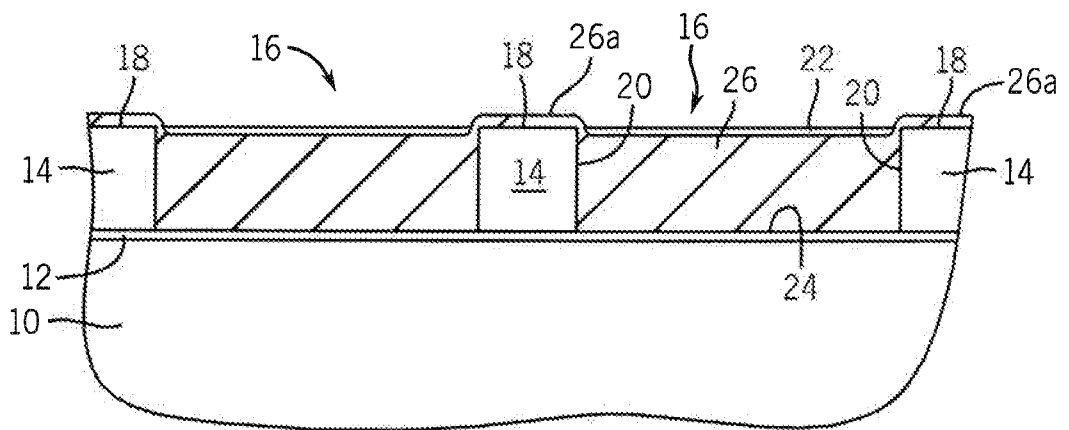
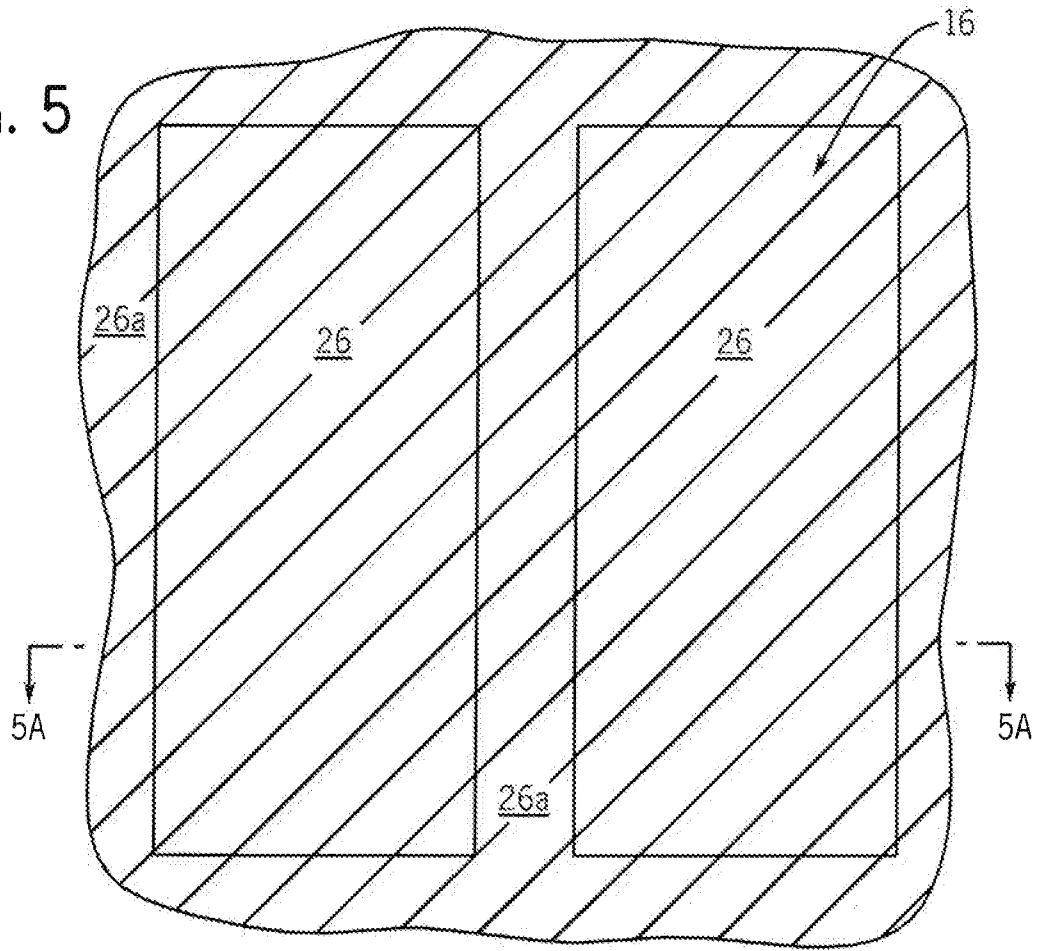

FIG. 5A

FIG. 6

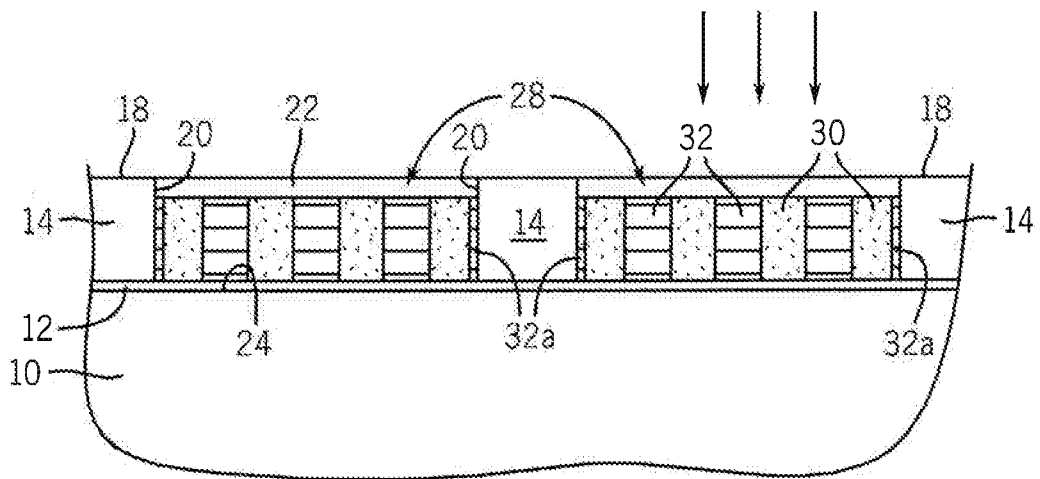
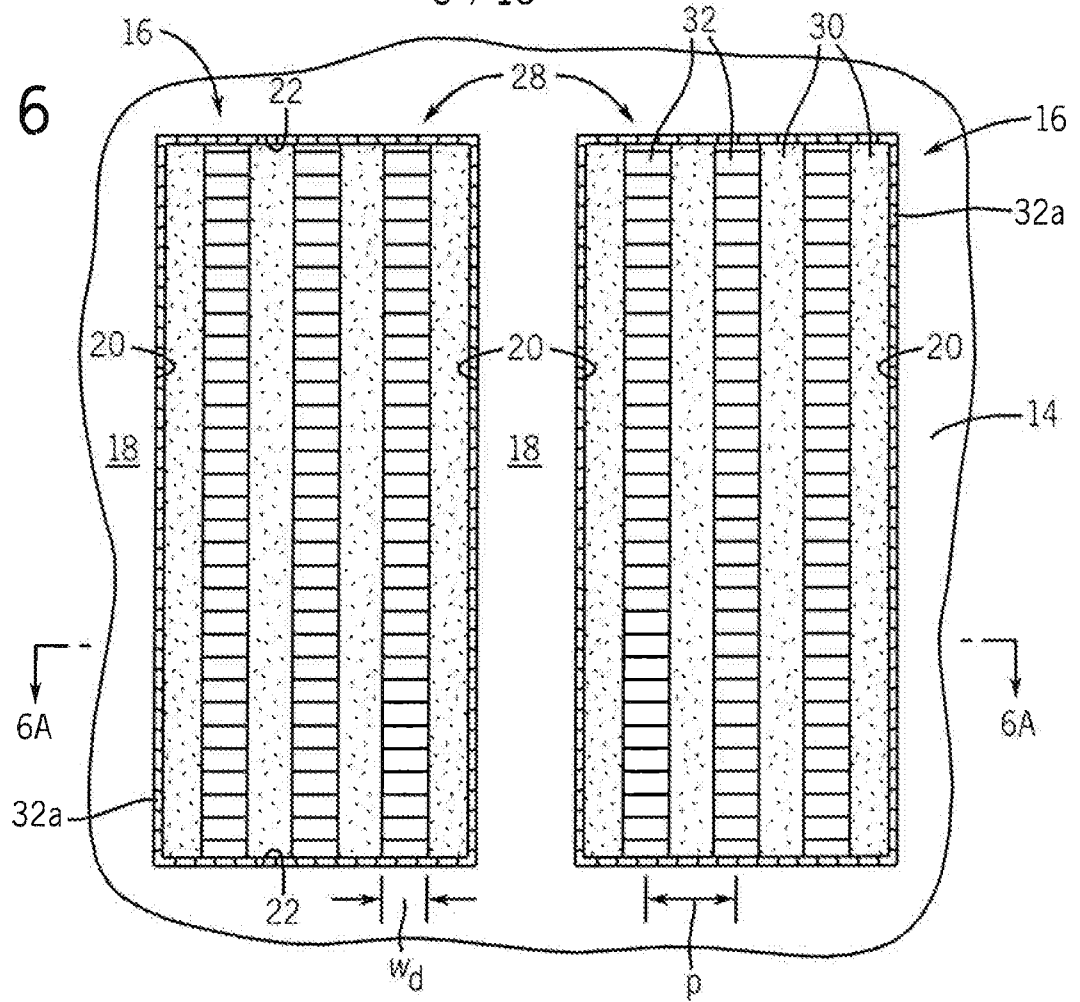

FIG. 6A

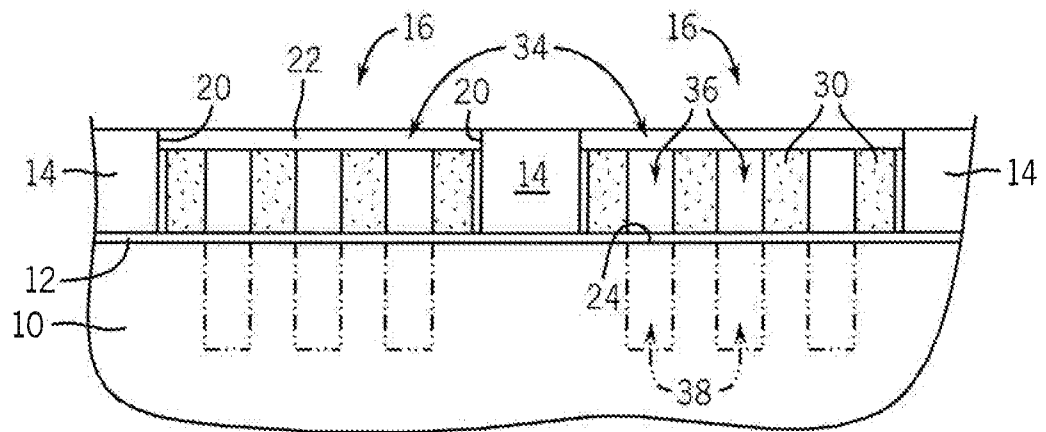
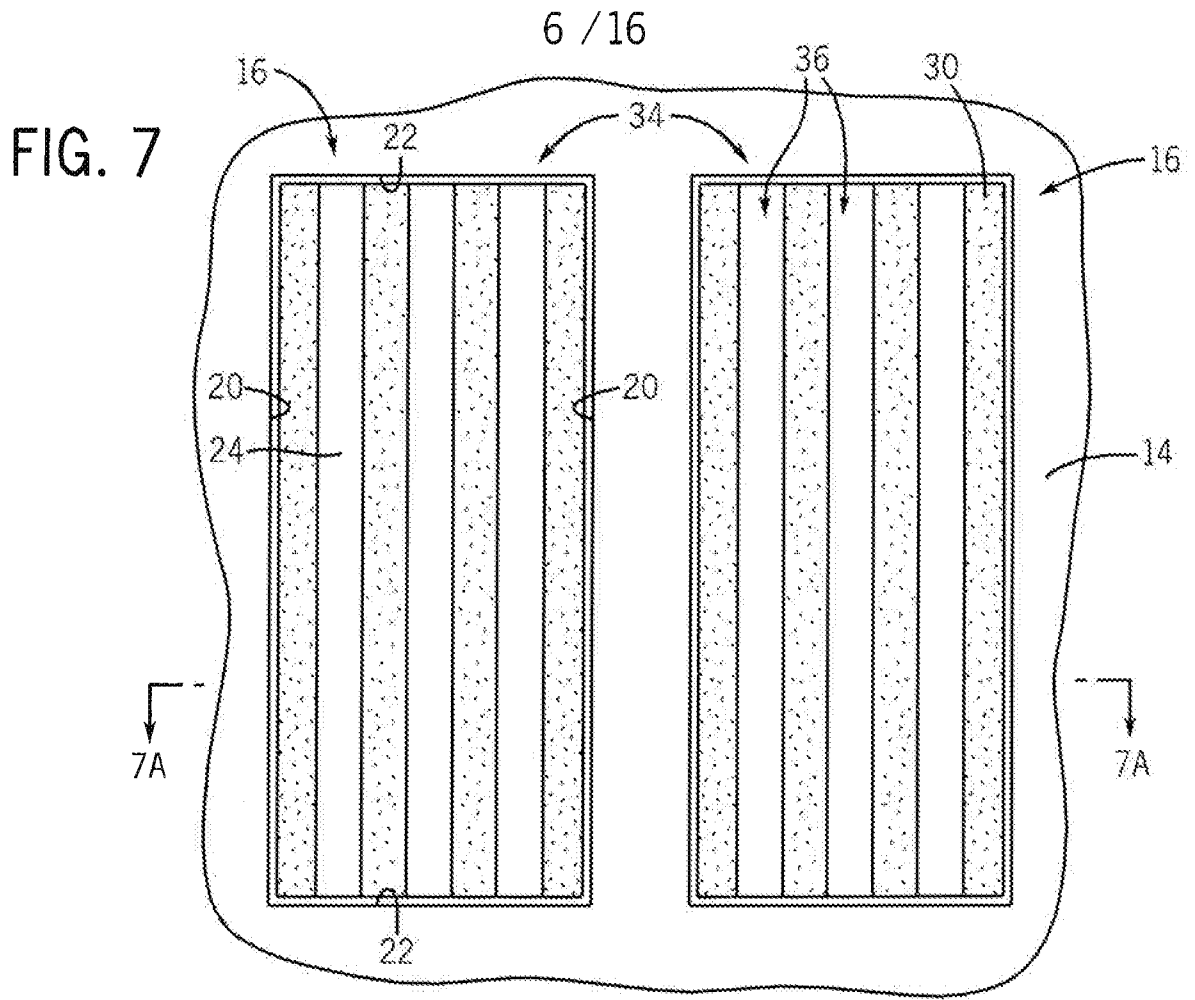

FIG. 7A

FIG. 8

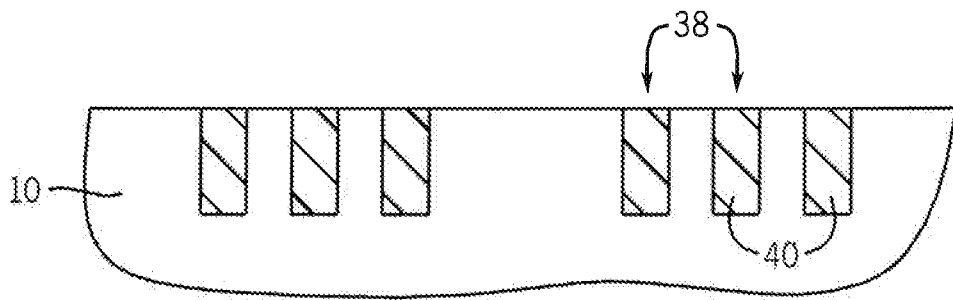
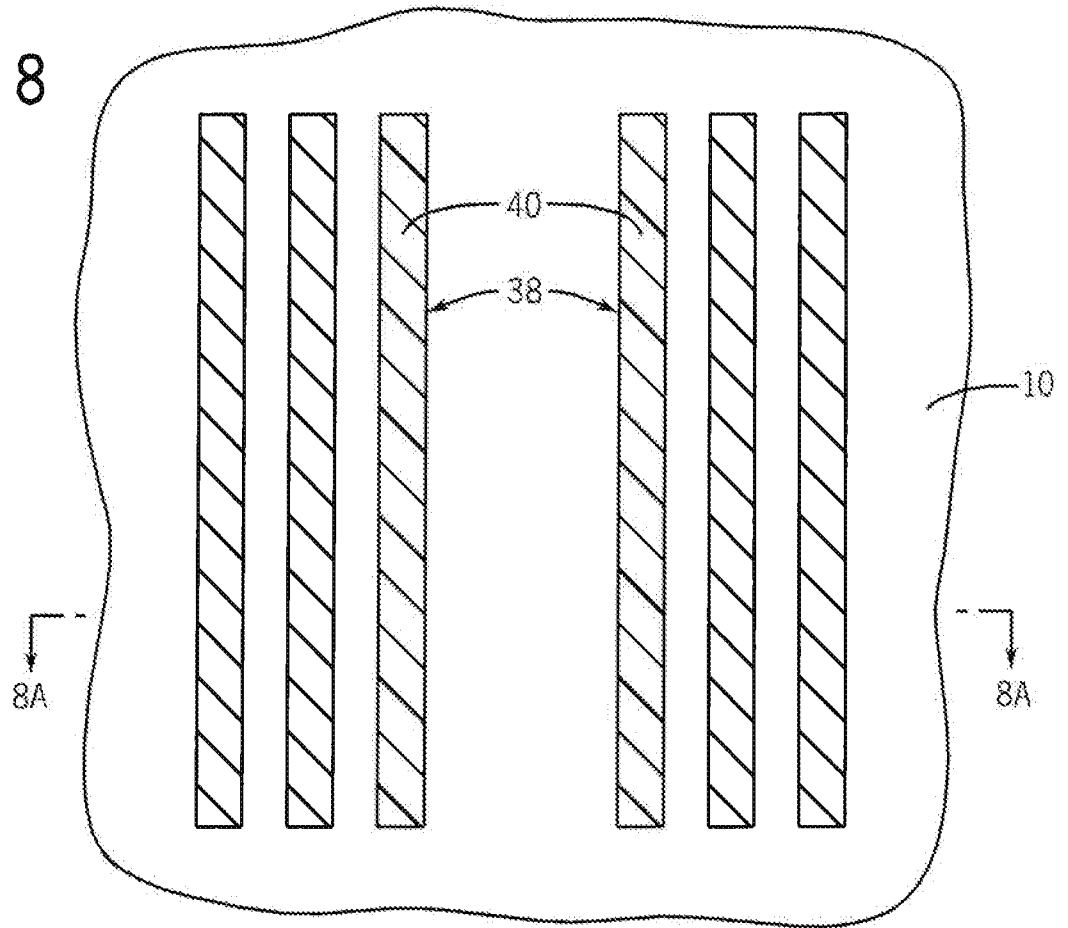

FIG. 8A

FIG. 9

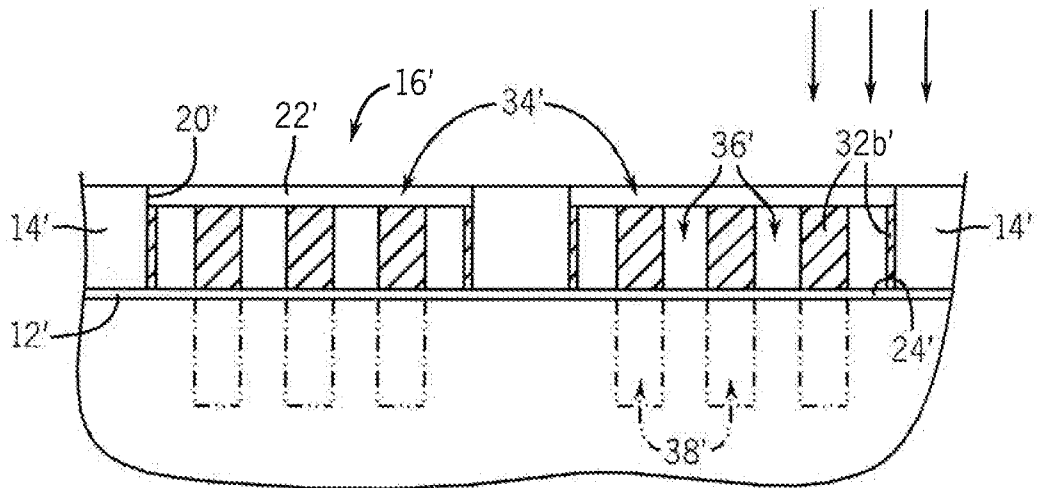
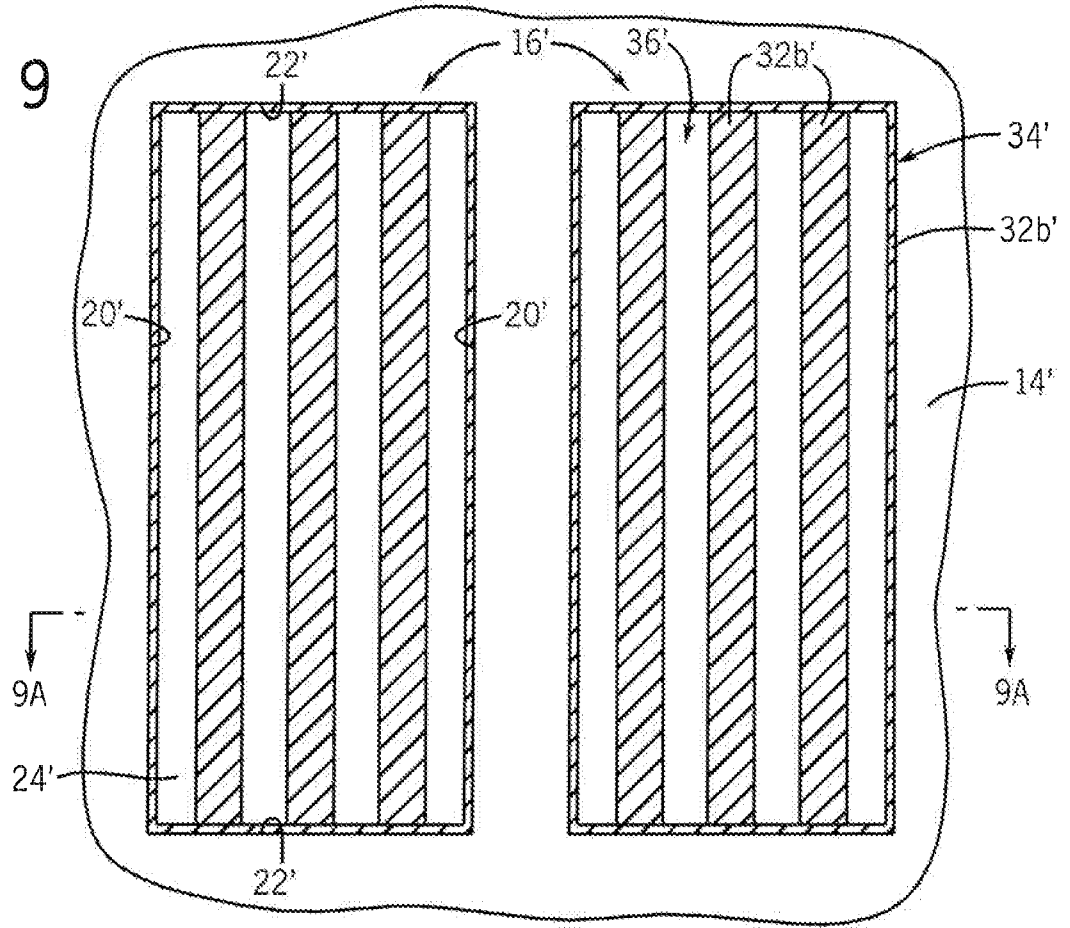

FIG. 9A

FIG. 10

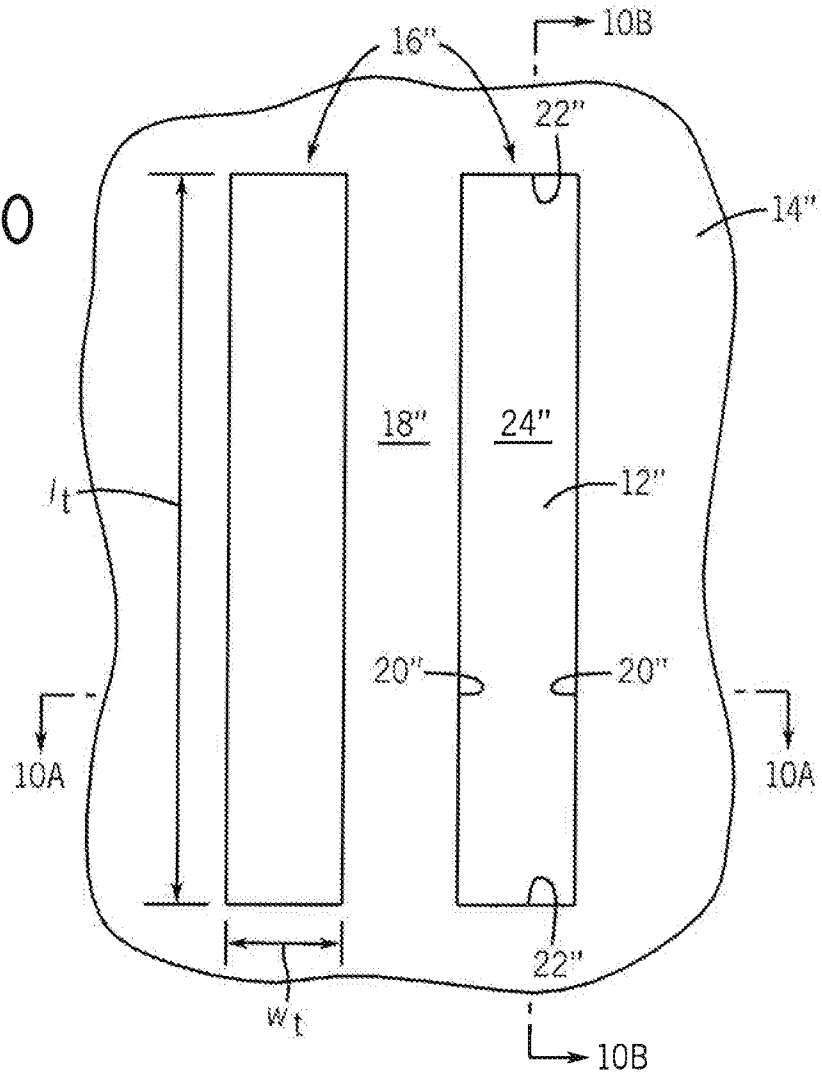
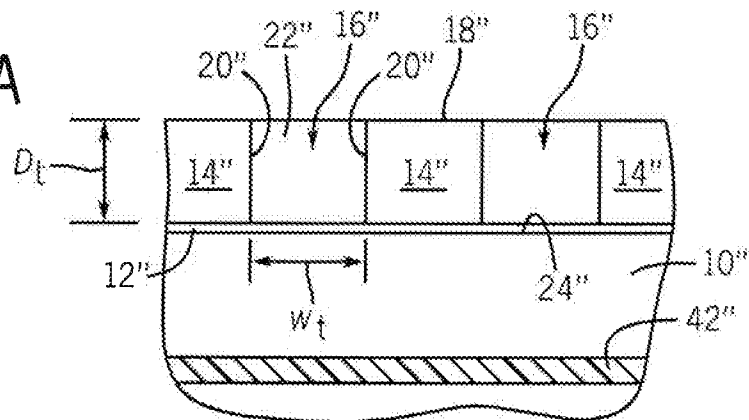

FIG. 10A



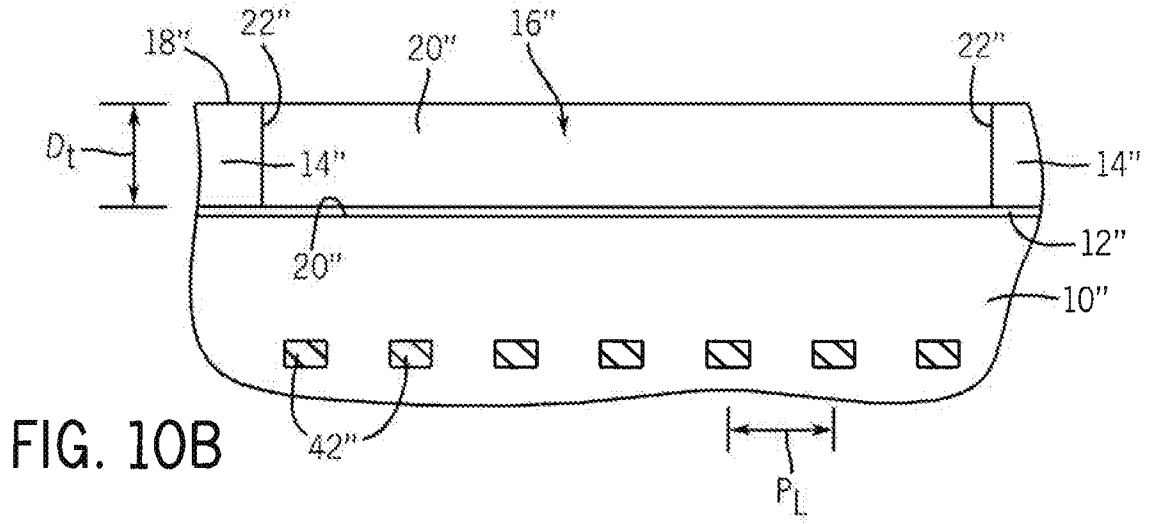

FIG. 10B

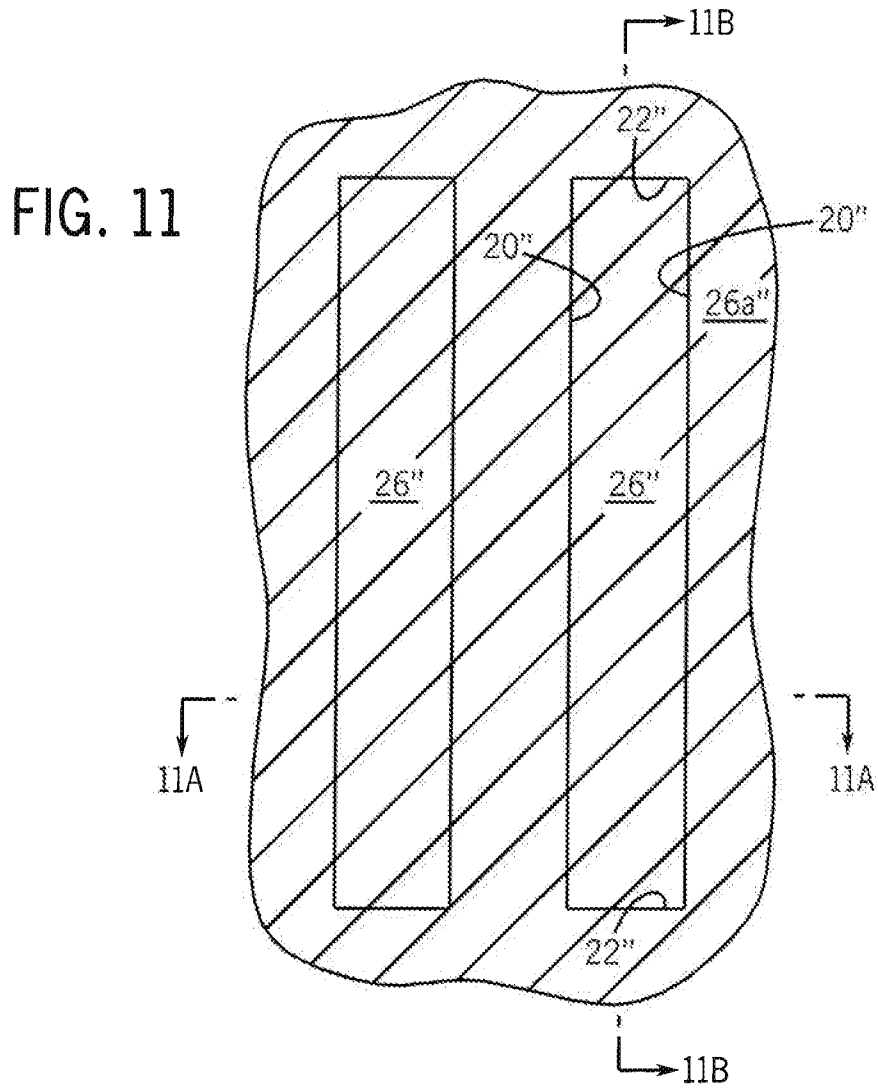

FIG. 11

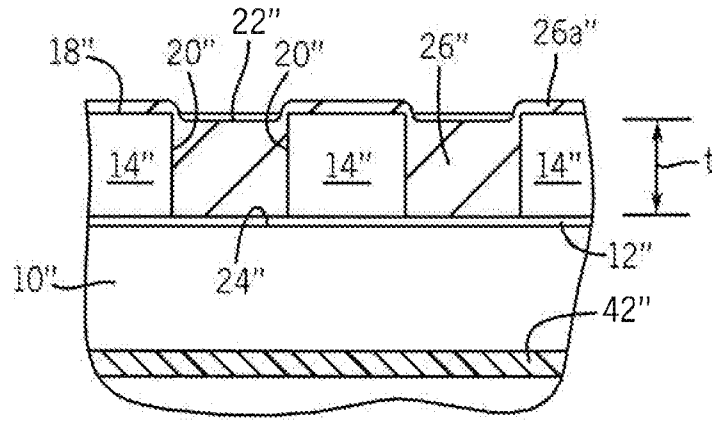

FIG. 11A

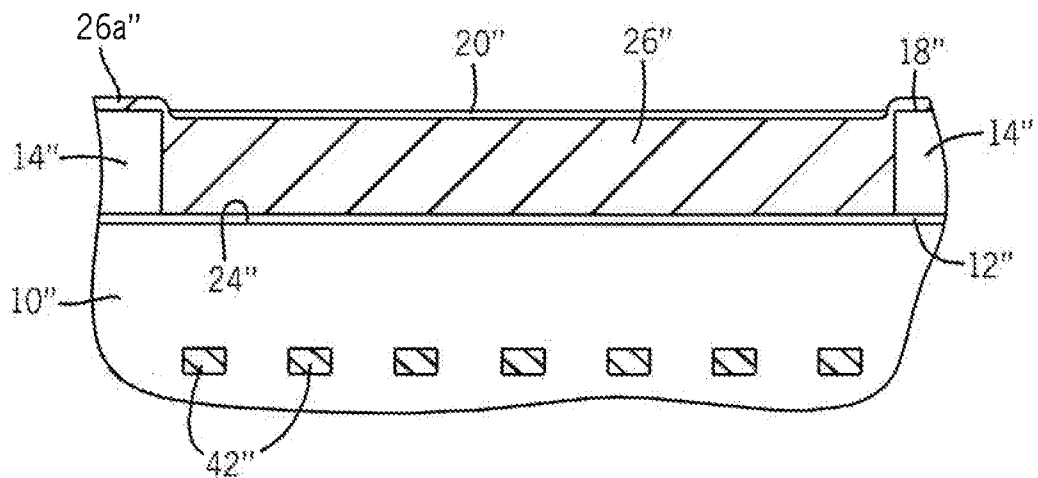

FIG. 11B

FIG. 12

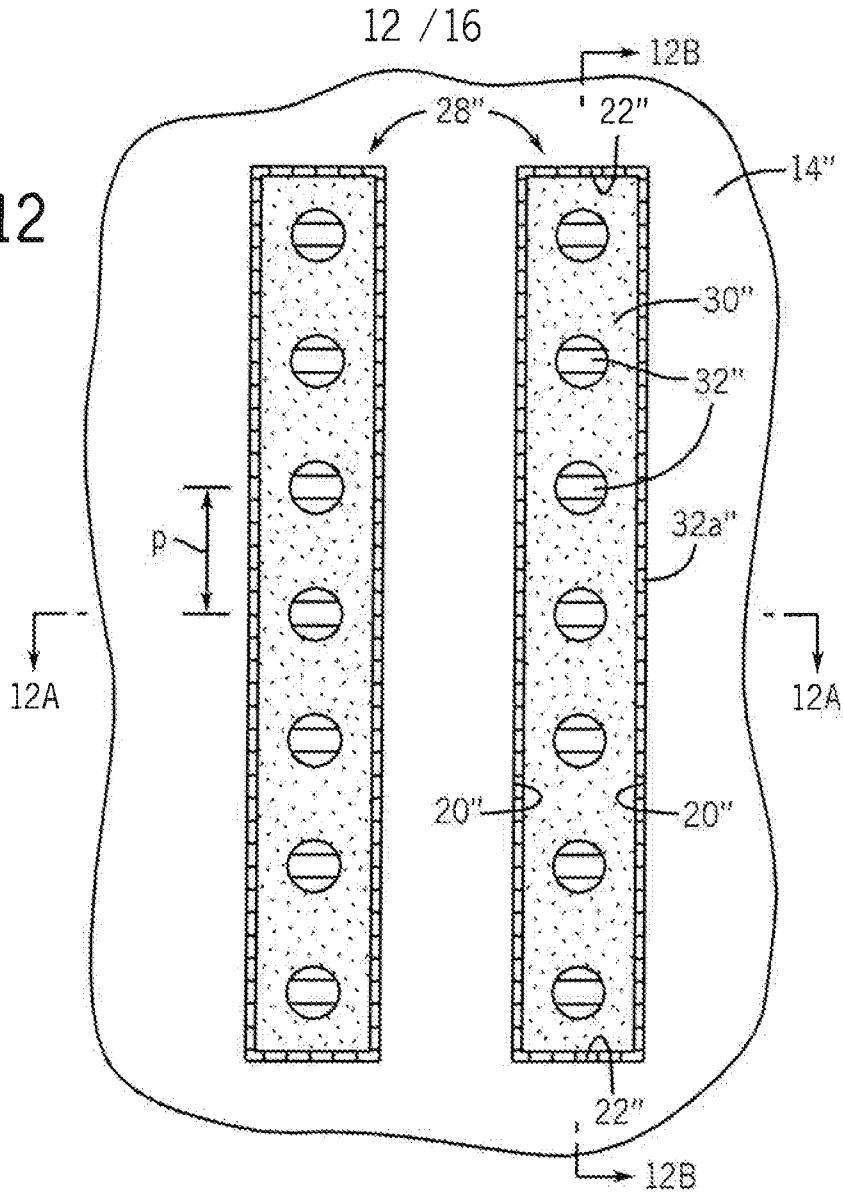
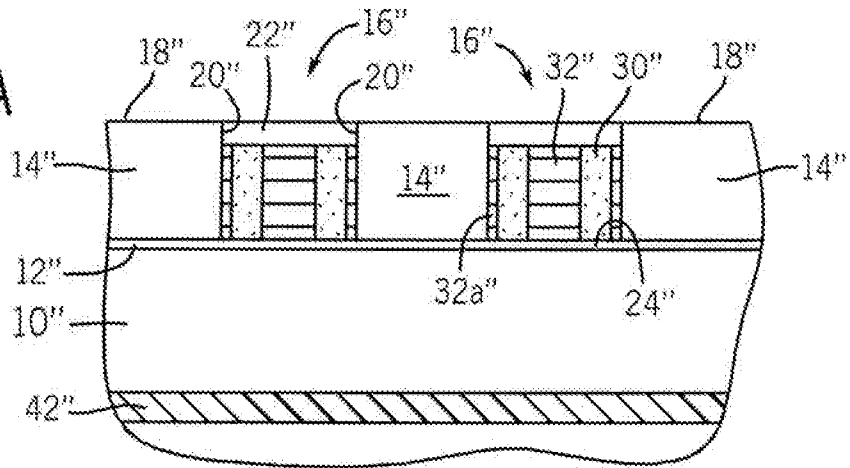

FIG. 12A



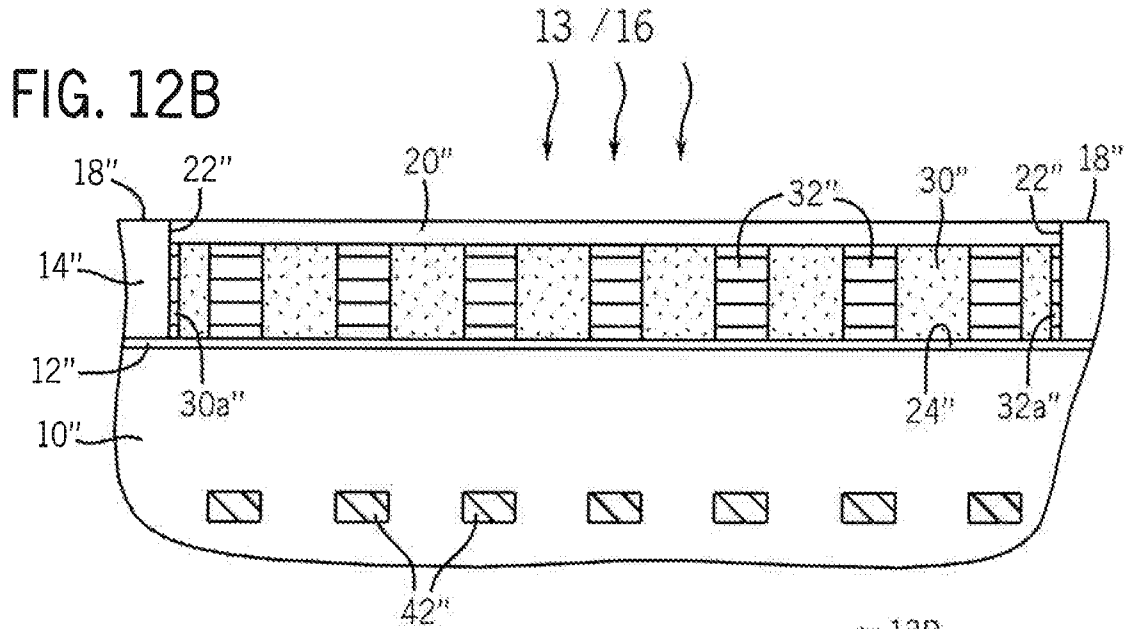
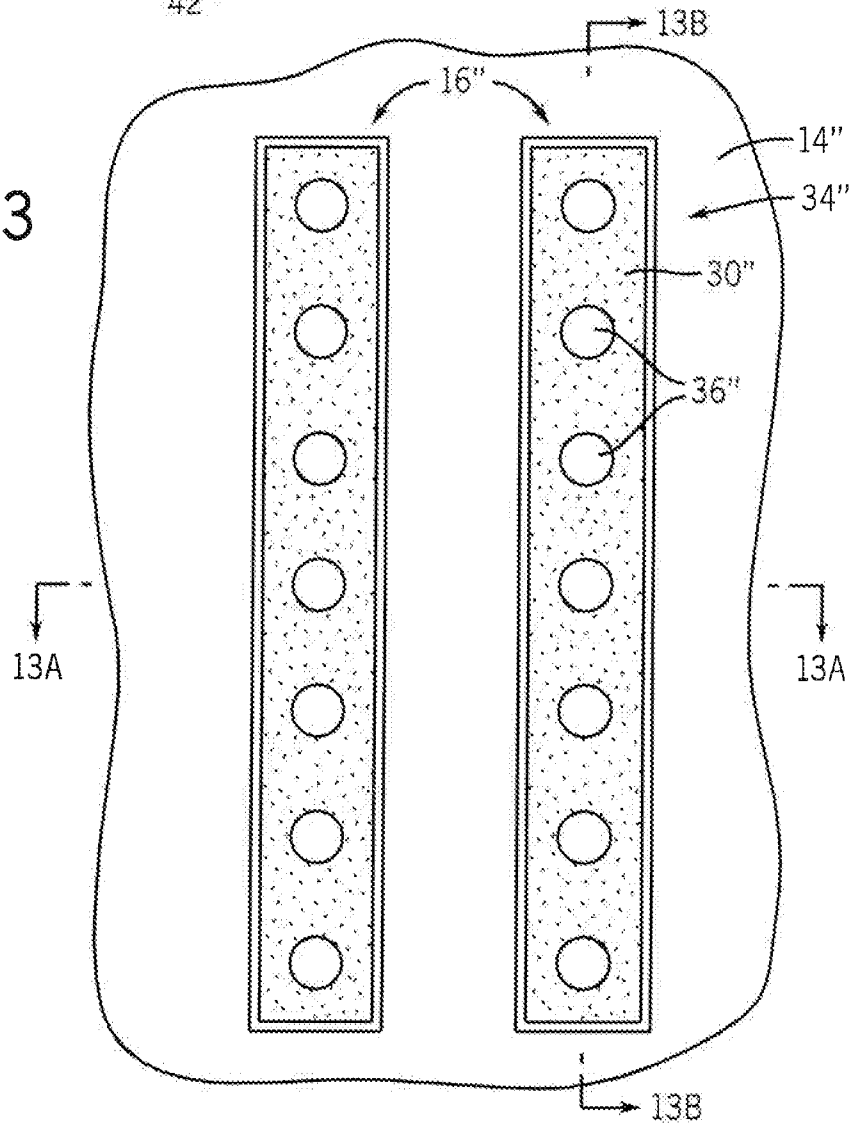

FIG. 13



14 / 16

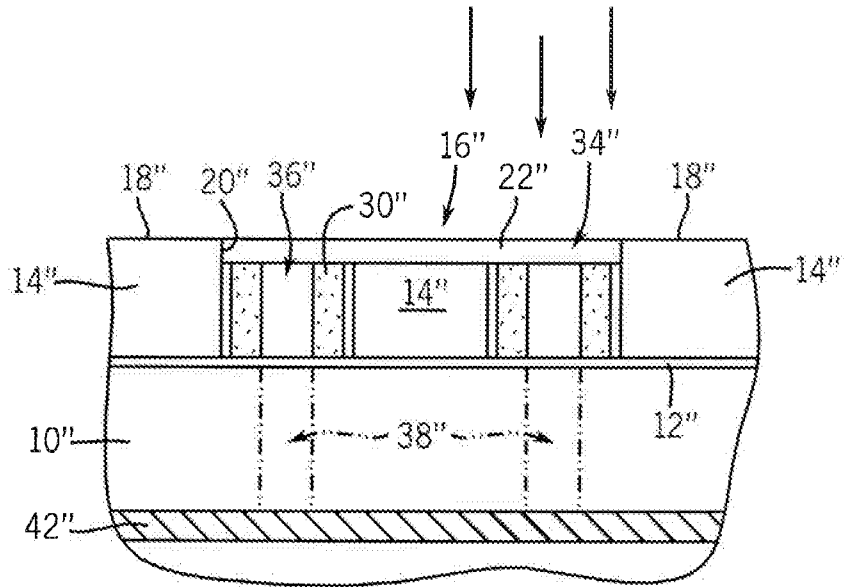

FIG. 13A

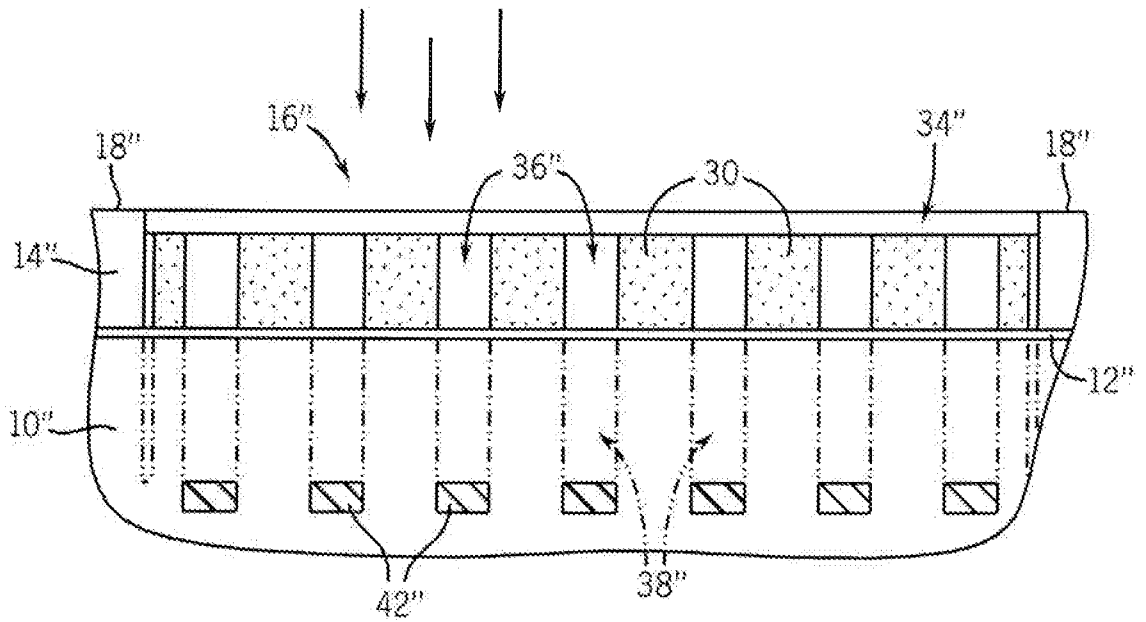

FIG. 13B

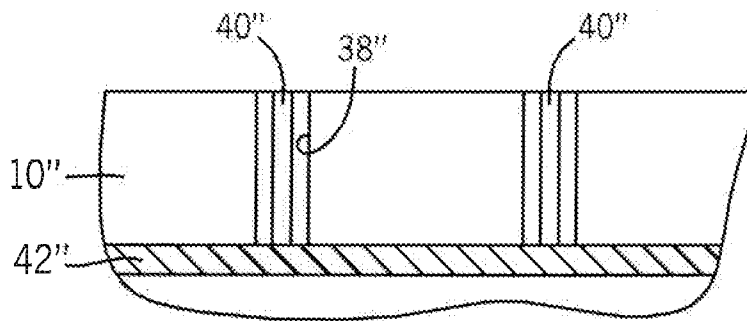
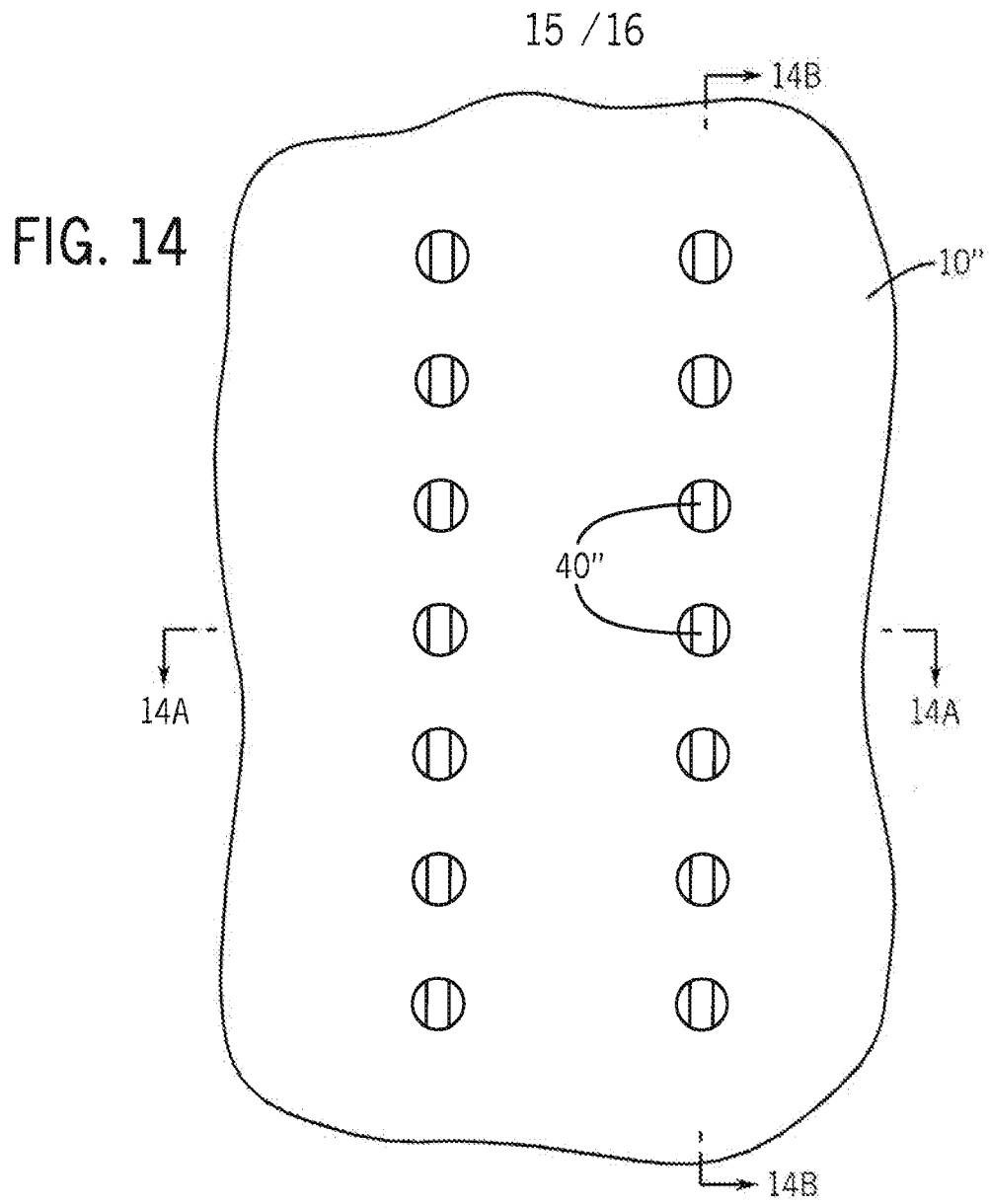

FIG. 14A

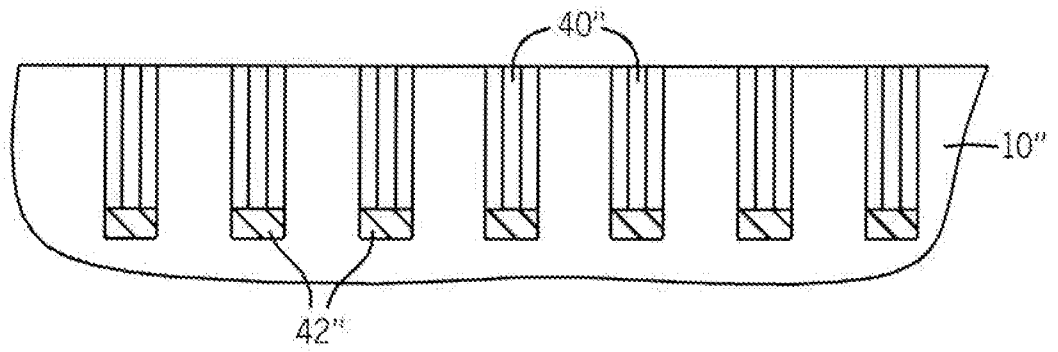

FIG. 14B