



(11) (21) (C) **2,195,329**  
(86) 1995/10/05  
(87) 1996/05/17  
(45) 2000/08/08

(72) Order, Michail, DE

(73) Order, Michail, DE

(51) Int.Cl.<sup>6</sup> A63F 1/14, A63F 1/18, A63F 3/00

(30) 1994/11/08 (P 44 39 502.7) DE

(54) **MATERIEL DE JEU POUR UTILISATION PROFESSIONNELLE  
DE JEUX SUR TABLE AVEC CARTES A JOUER ET JETONS  
DE JEU, EN PARTICULIER POUR LE JEU DE VINGT-ET-UN**

(54) **GAMING EQUIPMENT FOR PROFESSIONAL USE OF TABLE  
GAMES WITH PLAYING CARDS AND GAMING CHIPS, IN  
PARTICULAR FOR THE GAME OF "BLACK JACK"**

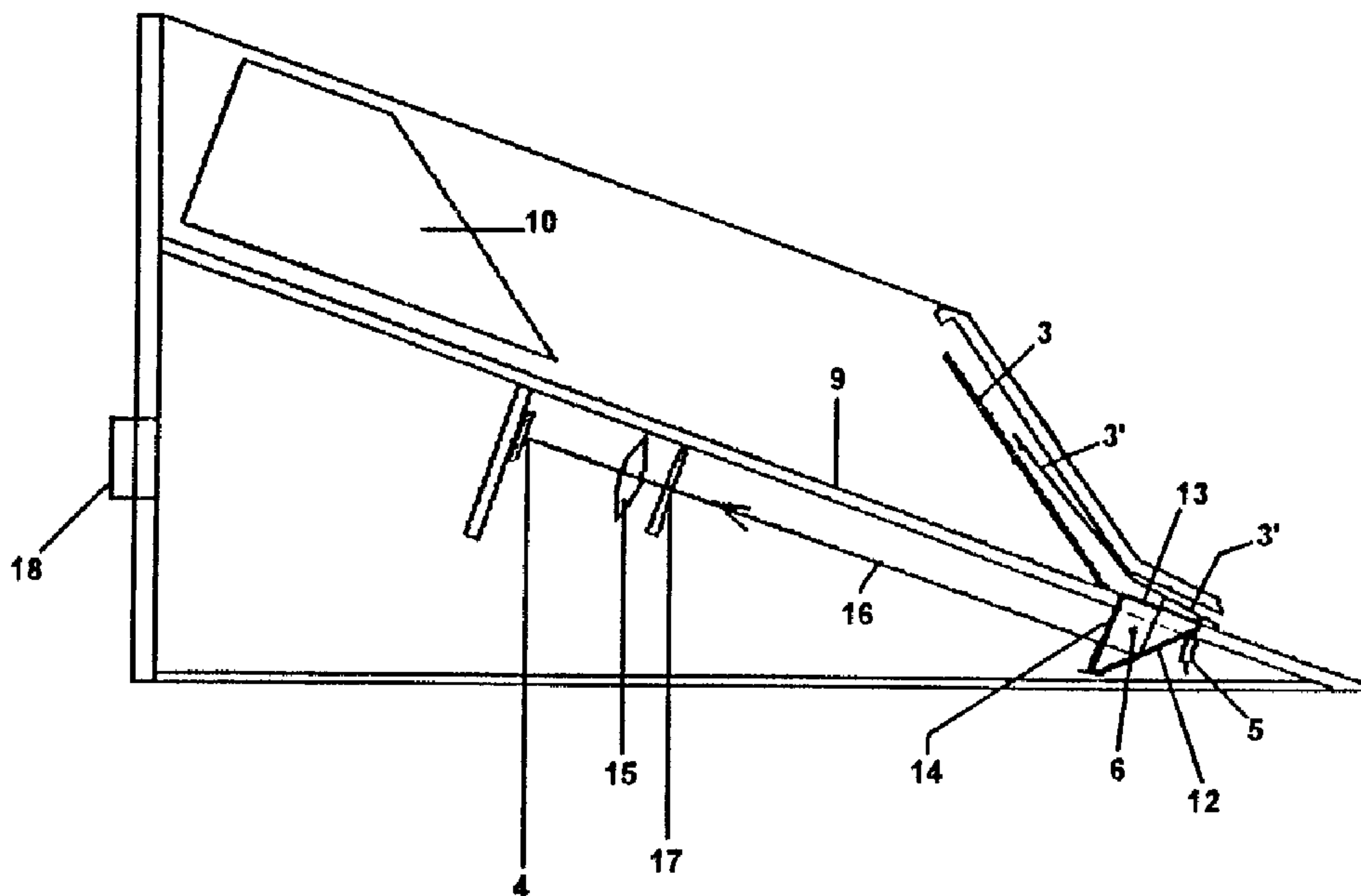

(57) L'invention a pour but de fournir une installation de jeu à contrôle automatique, avec enregistrement et évaluation automatiques de tous les déroulements d'un jeu, pour la pratique professionnelle de jeux se jouant sur une table au moyen de cartes à jouer et de jetons, en particulier du jeu dit "Black Jack". Ce but est atteint

(57) The object of the invention is to create a games system for use in professional card or token table games such as "blackjack" with automated monitoring and automatic recording and evaluation of all moves in a game. This is achieved by providing a card dispenser with a recognition device to recognise the value of a





(11) (21) (C) **2,195,329**  
(86) 1995/10/05  
(87) 1996/05/17  
(45) 2000/08/08

grâce au fait que l'installation précitée comprend un distributeur de cartes avec dispositif d'identification de la valeur d'une carte tirée (par détection optique du marquage de la valeur de la carte (31) et réflexion dans un convertisseur d'image à couplage de charge (CCD)); une table de jeu avec photodiodes (52) disposées sous le tapis (51) de la table, qui enregistrent séparément, pour chaque emplacement de dépôt (53, 54) pour les jetons (41) et pour chaque emplacement de réception (55, 56) pour les cartes (3), l'atténuation de la lumière ambiante du casino traversant le tapis lorsqu'un élément de jeu, carte ou jeton (3, 41), est déposé ou déplacé sur ces emplacements; un dispositif pour la détection, en particulier automatique, des mises (scanner ou système RFID à poste émetteur-récepteur et jetons transpondeurs); un ordinateur fonctionnant au moyen d'un programme de traitement électronique des données basé sur les règles du jeu, destiné à évaluer toutes les données reçues, relatives au développement du jeu, émanant des composants fonctionnels du système; ainsi qu'un écran pour l'affichage et le contrôle de l'état actuel du jeu, y compris l'affichage des gains des joueurs.

drawn card (by optical sensing of the card value mark (31) and reflection of it into an image sensor based on a charge-coupled device); a games table with photodiodes (52) positioned underneath the baize (51) which, for each set field (53, 54) for the tokens (41) and each laying field (55, 56) for the cards (3), register the attenuation of the ambient casino light penetrating the baize whenever a card or token (3, 41) is deposited or moved above them; a device for automatically sensing the stakes (scanner or RFID system with transmit-receive station and transponder tokens); a computer which operates an electronic data processing program based on the game rules in order to evaluate all the data on developments in the game fed to it from the functional components of the system; and a screen for displaying and monitoring the current state of play including the winnings of the participating players.



PCT

WELTORGANISATION FÜR GEISTIGES EIGENTUM  
Internationales Büro



INTERNATIONALE ANMELDUNG VERÖFFENTLICHT NACH DEM VERTRAG ÜBER DIE  
INTERNATIONALE ZUSAMMENARBEIT AUF DEM GEBIET DES PATENTWESENS (PCT)

<p>(51) Internationale Patentklassifikation <sup>6</sup> : A63F 1/14, 3/00, 1/18</p>	<p>A1</p>	<p>(11) Internationale Veröffentlichungsnummer: <b>WO 96/14115</b>  (43) Internationales Veröffentlichungsdatum: 17. Mai 1996 (17.05.96)</p>
<p>(21) Internationales Aktenzeichen: PCT/DE95/01389 (22) Internationales Anmeldedatum: 5. Oktober 1995 (05.10.95) (30) Prioritätsdaten: P 44 39 502.7 8. November 1994 (08.11.94) DE (71)(72) Anmelder und Erfinder: ORDER, Michail [DE/DE]; Ostlandstrasse 96, D-50859 Köln (DE). (74) Anwälte: LOTTERHOS, Herbert usw.; Lotterhos &amp; Partner, Lichtensteinstrasse 3, D-60322 Frankfurt am Main (DE).</p>	<p>(81) Bestimmungsstaaten: AU, BG, BR, BY, CA, CN, CZ, FI, HU, JP, KR, MX, NO, NZ, PL, RO, RU, SG, SI, SK, UA, US, VN, europäisches Patent (AT, BE, CH, DE, DK, ES, FR, GB, GR, IE, IT, LU, MC, NL, PT, SE).</p> <p>Veröffentlicht <i>Mit internationalem Recherchenbericht. Vor Ablauf der für Änderungen der Ansprüche zugelassenen Frist. Veröffentlichung wird wiederholt falls Änderungen eintreffen.</i></p> <p style="text-align: center; font-size: 2em;">2195329</p>	

(54) Title: GAMES SYSTEM FOR PROFESSIONAL CARD OR TOKEN TABLE GAMES, IN PARTICULAR "BLACKJACK"  
(54) Bezeichnung: SPIELANLAGE ZUR PROFESSIONELLEN AUSÜBUNG VON TISCHSPIELEN MIT SPIELKARTEN UND JETONS, INSBESONDERE DES SPIELES "BLACK JACK"

(57) Abstract

The object of the invention is to create a games system for use in professional card or token table games such as "blackjack" with automated monitoring and automatic recording and evaluation of all moves in a game. This is achieved by providing a card dispenser with a recognition device to recognise the value of a drawn card (by optical sensing of the card value mark (31) and reflection of it into an image sensor based on a charge-coupled device); a games table with photodiodes (52) positioned underneath the baize (51) which, for each set field (53, 54) for the tokens (41) and each laying field (55, 56) for the cards (3), register the attenuation of the ambient casino light penetrating the baize whenever a card or token (3, 41) is deposited or moved above them; a device for automatically sensing the stakes (scanner or RFID system with transmit-receive station and transponder tokens); a computer which operates an electronic data processing program based on the game rules in order to evaluate all the data on developments in the game fed to it from the functional components of the system; and a screen for displaying and monitoring the current state of play including the winnings of the participating players.

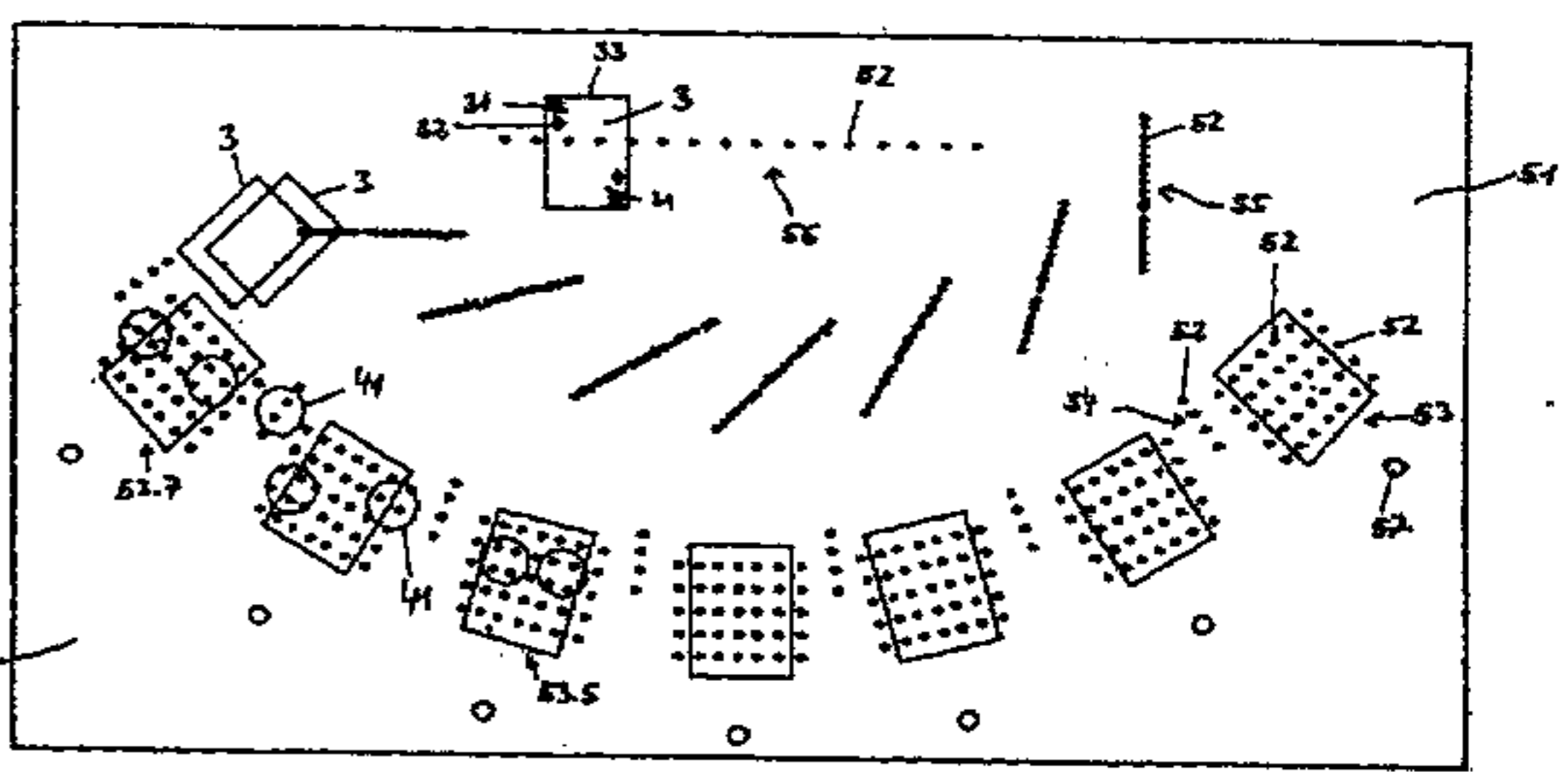

(57) Zusammenfassung

Die Erfindung bezweckt, zur professionellen Ausübung von Tischspielen mit Spielkarten und Jetons, insbesondere des Spieles "Black Jack", eine automatisch überwachte und sämtliche Spielabläufe selbsttätig registrierende und auswertende Spielanlage zur Verfügung zu stellen. Dies wird erreicht durch einen Kartenspender mit Erkennungseinrichtung für den Kartenwert der gezogenen Spielkarte (optische Erfassung des Kartenwertaufdruckes (31) und Einspiegelung in einen CCD-Bildwandler); einen Spieltisch mit unter dem Spieltuch (51) angeordneten Photodioden (52), welche getrennt für jedes Satzfeld (53, 54) für die Jetons (41) und jeden Ablageplatz (55, 56) für die Spielkarten (3) die Schwächung des durch das Spieltuch hindurchscheinenden Casinolichtes registrieren, wenn ein Spielgegenstand (3, 41) über ihnen aufgelegt oder verschoben wird; eine Einrichtung zur insbesondere automatischen Erfassung des Spieleinsatzes (Scanner oder RFID-System mit Sende-Empfangsstation und Transpoder-Jetons); einen mittels eines spielregelgerechten EDV-Programmes arbeitenden Computer zur Auswertung sämtlicher ihm von den funktionellen Anlageteilen zum Spielverlauf zugeleiteten Daten; und einen Bildschirm zur Anzeige und Überwachung des aktuellen Spielgeschehens einschließlich der Anzeige der Spielergewinne.

Gaming Equipment for professional use of table games with playing cards and gaming chips, in particular for the game of "Black Jack".

5 DESCRIPTION

Technical Field

10 The invention concerns a gaming equipment for professional use in games of chance such as "Black Jack" and related games by using playing cards and gaming chips (jettons).

The following explications mainly relate to the game of "Black Jack" which will be used by the way of an example.

15

Conventionally a gaming equipment for "Black Jack" basically consists of a gaming table and a card dispenser in the form of a card slide, which is also referred to as card shoe, because of its shape.

20

"Black Jack" is played with 1 to 8 decks each consisting of 52 cards, whereby the player plays against the bank (house) and the house is represented by the croupier, also called dealer at the game of "Black Jack".

25

Every deck of cards consists of four suits of cards, Hearts, Diamonds, Clubs and Spades. Each suit has nine numbered cards and four pictured cards, with the picture of Jack, Queen, King and Ace. The number cards are designated by their numbers 2 through 10 and the picture cards are designated by their initials:

30

J (Jack), Q (Queen), K (King) and A (Ace). The name of each card is a combination of its value and its suit (e.g. Queen of Diamonds). In the game of "Black Jack" the value of points of the ace may be selected by choice to be either 1 or 11, the value of points of the picture cards (Jack, Queen, King) is 10 and the

35

gaming value of all other cards equal to their faced value; the colors or suits have no meaning to the game.

5 Prior to the start of the first game the cards are carefully shuffled by the dealer, preferably by using a card shuffling device, and then placed into the card shoe in such way, that the neutral backside of the cards shows forward, that is into direction of the card delivery opening of the card shoe.

10 The "Black Jack" table is covered by a piece of cloth (gaming layout) which is essentially divided into rectangular or round betting fields (boxes, hands) arranged like half a circle and designated for placement of the bets in form of gaming chips. At the left side of each box there is an insurance field (line). One  
15 part of the gaming table is designated for placement of the cards for the players and the dealer.

The basic features of the game of "Black Jack" are as follows:

20 As many players (or groups of players) as the gaming area has boxes, may take action (generally seven).

Target of the players is to achieve a higher score than the bank. The highest score which must not be exceeded neither by the  
25 players nor by the bank, is 21. The player or the bank has "Black Jack" and wins, if they have reached a score of 21 with the received first two cards. Otherwise the party being closer to the score of 21 has won. In case of same score for both parties the player does not win nor loose, and he can withdraw his bet or  
30 play it again or raise or reduce it for the next game.

According to internationally determined rules of gaming performance, placing bets and distribution of cards are done as follows.

First each player makes his bet; if more than one chip is placed, the chips are stacked with the highest denomination at the bottom of the stack and the lowest denomination at the top. Then the dealer distributes the cards from the left to the right so that  
5 first each player and then the dealer receives the first card face up. After that each player receives the second card also face up and then the dealer his second card but face down. If the player has not gotten "Black Jack" he may ask the dealer for more cards face up.

10

When all the players' cards have been dealt the dealer turns his face down second card to face up. If the dealer's score is 17 or higher he must not take another card; if his score is less than 17, he has to take further cards until his score has reached or  
15 passed 17.

In addition, under certain circumstances and conditions there may apply gaming variations, such as "Backing the Box", "Double down", "Split" and "Insurance".

20

At "Backing the Box" several players (community of players) place their bets in one and the same box.

25

At "Double down" the player may double his initial bet during the game, whereby he has to place the double bet next to the initial bet in his box.

30

At "Split" player splits the initial two cards and continues his game playing on two hands with two rows of cards, that requests to double the initial bet.

35

At "Insurance" player insures his bet against "Black Jack" of the bank, whereby he has to bet half of the value of the initial bet on the insurance line.

Player wins at "Black Jack" 3 units for 2, otherwise he wins 1  
for 1, and at "Insurance" and "Black Jack" of the bank all  
insurance bets get 2 units for 1; if the bank fails to have  
"Black Jack" after an insurance bet, player loses his insurance  
5 bet, but plays a regular game using his initial bet.

The cards of the players are placed in a staggered way, so that  
all card values stay visible. The dealer's cards are placed side  
to side without overlapping each other.

10 The gaming chips (jettons) are disk like pieces of plastic. Their  
value is printed (e.g. 10, 20, 50, 100, 500) and they are marked  
by different colors (e.g. blue, red, green, orange, violet)  
according to their respective value.

15 The invention bases on following problems:

In casino business there is a lack of technical control at the so  
called table games (live games); this concerns in particular the  
20 card game "Black Jack" which may be played in various ways. Even  
by high substantial staff complement in form of additional  
monitoring staff and despite the use of optical surveillance  
systems, there are considerable security loopholes which may  
result in a reduced gaming revenue for the casino or the casino  
25 operator. On the other side there is a lot of responsibility with  
the dealers, who need a high level of concentration to maintain a  
strictly regulated game same as correct payments of wins to  
players. He has to account against the bank at the end of each  
duty and during all these duties errors may arise.

30 Therefore it is necessary to find a solution, which will allow a  
reliable surveillance during the whole gaming performance without  
human manpower. It should recognize appearing errors and mistakes  
same as incorrect decisions by the dealer and ease to correct  
35 them. In the event of disagreement between player and dealer or

between the dealer and casino operator, it should be possible to  
revise any game in a reliable manner; a solution which avoids  
incorrect ways to influence the game in particular in favor of  
certain players at the calculation of wins or at the payment of  
5 wins; a solution which creates an easier job for the dealer; a  
solution which, apart of other advantages, simplifies the process  
of accounting between the dealer and the casino management in a  
correct and comfortable manner. Beside that it is a target to  
deliver firm information about the dealers performance and the  
10 individual gaming characteristics of the player.

To achieve the outlined concept of solutions for the described  
problems, the object of the invention is to provide a fully auto-  
matic system of surveillance, controlling and tracking in  
15 particular for the game of "Black Jack"; it should survey,  
control, track and permit to use the registered data under  
different circumstances depending on gaming and casino specific  
needs, digest and monitor them from the moment when the card  
leaves the card shoe until the moment of calculation of the  
20 result of the actual game.

This requires the following:

The ran of the game shall be automatically tracked in, if possi-  
25 ble, all phases of the game and by the use of a computer and a  
specific electronic data processing program, being tracked,  
stored, and shown on a monitor or display, visible for the  
dealer.

30 The card shoe shall include a device for automatic recognition  
and tracking of the value of each gaming card drawn out of the  
card shoe in a covered way (face down).

The gaming table shall include a device for automatic recognition  
35 of played or not played boxes (hands), whereby it has to realize

multiple bets on each hand and the use of insurance lines. Over-  
more, the gaming table shall include a device to recognize auto-  
matically the number of cards placed in front of each player and  
the dealer.

5

The values of the gaming chips used shall be recognized, tracked  
and stored.

10

In particular, the electronic data processing (EDP) program shall  
process the value of all bets on each box and associated  
insurance line; shall control the sequence of delivery of the  
cards, shall control the distribution of the gaming cards to each  
player and the dealer, shall calculate and compare the total  
score of each hand and the dealer's, and shall evaluate the  
players' wins.

15

All important gaming data shall then be processed by means of EDP  
program and shown simultaneously to the actual game at a special  
monitor or display. Same data shall be recalled later on to  
monitor the total results whenever requested, whereby there  
should not be any limits to the possible variations of EDP  
software program.

20

This complex task is solved, departing from a gaming equipment  
according to the generic part of patent claim 1, in accordance  
with the characterizing features of patent claim 1; more specific  
improvements and further developments of the invention are  
defined in the dependent claims 2 to 14.

25

### 30 State of the Art

It should be mentioned that according to the prior art there is  
no solution publicly known and available for this complex task.

According to DE 38 07 127 A1 there is known a device for registration of value of playing cards, but this device does not mean a card shoe for covered distribution of playing cards and is a device for calculation of total scores, which every player has  
5 got in his hands at card games like Skat, Romme, Bridge, Poker at the end of each game. This device helps to faster calculate and register the results of the game, which preferably are monitored on a display of the device. In order to read their value, the playing cards are preferably marked by a machine readable bar-  
10 code system and are placed inside of the device and pursuit through the device automatically card by card.

On the other hand, according to US 5 078 405 A, there are known table games for casinos available for games like Black Jack and  
15 Poker, which provide side games for Jackpot systems. To this end the in general regular gaming table includes coin acceptors and counting meters which register the coins entered and the total amount available for the Jackpot unit, same as a processor to calculate the Jackpot payout. Each player has the option, beside  
20 the basic game as Black Jack or Poker, to join playing the side game by entering a coin of one general value unit (e.g., one Dollar) into the coin acceptors entrance in front of his box. According to the result of the basic game and the rules of the extra game the player may have a portion or the total of the  
25 presented Jackpot or nothing. However, this device for the side game is not linked to the procedure of the basic game, and for sure not dedicated to monitor, control or survey the basic game itself.

30 In the following the invention is explained in general and, using principle figures, for the example of the game of "Black Jack" in particular.

Short Description of the Figures

It shows:

- 5 Fig. 1 a card shoe according to the invention, in a vertical cross-sectional side view;
- Fig. 2 a horizontal cross-sectional view from above of the card shoe of Fig. 1;
- Fig. 3 a front view of the card shoe of Fig. 1;
- 10 Fig. 4 a top view of the essential part of the gaming surface of a "Black Jack" gaming table according to the invention with hidden devices arranged under the cloth of the gaming layout for automatic recognition of use of gaming chips at boxes and insurance lines on the one
- 15 hand, and the location of distributed and placed playing cards on the other hand.

Modes of Realization of the Invention

- 20 The following explanations relate to a card shoe according to the invention.

The design of the card shoe as shown in Fig. 1 through Fig. 3 follows, concerning its outside shape and its upper part, in general the shape of regular conventional card shoes. According

25 to the invention there is provided an integrated device for recognition of the cards' value of the cards 3' drawn out of the card delivery 2 face down (Card Value Recognition Device, CVRD). This CVRD includes essentially following functional parts: one TV

30 camera or CCD-image converter 4 (charge-coupled device); an impulse light source 5 (flash light lamp) to illuminate that part of the drawn card 3', which holds the card value imprint 31; an optical right angle deviating prism 6 for illumination of the card value imprint 31 and for the transmission of the illuminated

35 card value imprint 31 over an optical path into the CCD-image

converter 4; and two optical electronic movement or position sensors 7, 8, to determine the movement of the drawn card 3' and to control the impulse light source 5.

5 The playing cards 3, for which the Queen of Diamonds serves as an example in Fig. 4, are in conformity with the international standard for card format and illustrations; the dimensions of each playing card 3 are 88 mm x 62 mm (vertical size) and there is a white framing around the central illustration. The card value imprint 31 is placed just below the top edge of the card on the left hand side (e.g., the capital Q), and just below the value - separated by a white space - is the colored suit symbol 32 (e.g., the diamond symbol). The card name, made up of the color suit symbol 32 and the card value imprint 31 is also printed in the right hand bottom corner of the card (upside down). The card name for the color suit symbols is black for Clubs and Spades and red for Hearts and Diamonds; the height of the card value imprint 31 is (up to) 15 mm.

20 The playing cards 3 have been placed in the card shoe 1 in such a way that one of their transverse sides 33 is resting at a forward inclined slant or support 9, and the cards are inclined backwards and face down. The angle of the cards 3 against the support 9 is determined by a trapezoidal sliding wedge 10, which also pushes the cards 3 toward the card delivery 2. For the sake of clarity, only two playing cards 3, 3' are shown in Fig. 1; card 3' is in the position of being drawn by the dealer.

30 The support 9 extends over the card delivery 2 and has, in the vicinity of the card delivery, but still on the inside of the card shoe 1, a window 11 which is covered by one of the optical planes of the rectangular deviating prism 6 and lies in the path of the card value imprint 31. Therefore the prism 6 must be basically arranged on the left or the right border of the path of the drawn card 3'.

35

The prism 6 is arranged in such a way that its plane 12 opposite to its right angle, in the following referred to as mirror plane, shows in the opposite direction with respect of the CCD-image converter 4. The plane 13 of the prism 6 constituting the window 11, in the following referred to as window plane, and the plane 14 of the prism 6, which looks towards the CCD-image converter 4, is referred to as exit plane.

The impulse light source 5 is just below the mirror plane 12 in the vicinity of that end of the deviating prism 6, that forms the angle (of 45 degree) with the window plane 13. The light of the impulse light source 5 falls through the mirror plane 12 and the window plane 13 onto the picture side (illustrated side) of the card 3', is reflected from the illuminated card 3' through the window plane 13 onto the mirror plane 12 and is then reflected through the exit plane 14 in the direction of the image converter 4, so that that part of the card 3' being over the front of the window 11 will be projected on the image converter 4 by means of a convex lens 15. A red light filter 17 (>600 nm), lying in the light path 16 in front of the lens 15, serves to the registrability of red colored card values imprints 31. Because of the optical geometric set-up of the light source 5 toward the prism 6, the light source 5 will not be immediately transmitted to the image converter 4.

Instead using a deviating prism 6 for passing the depicted image of the illuminated card value imprint 31 through an optical path into the CCD-image converter 4, one can use advantageously a non-transparent mirror (not shown) which will then occupy the position of the mirror plane 12 of the prism 6. In this case the impulse light source 5 is to be arranged in front of the mirror plane 12 (of the mirror), instead of behind the mirror plane 12, and is to be screened in such a way that the light source 5 does

not shine immediately either in the image transformer 4 or in the mirror.

5 For the intended depiction of the card value imprint 31 of the drawn card 3' in the image converter 4, it is necessary that the impulse light source 5 flashes at exactly the same time as the (facing down) card value imprint 31 is over the window 11.

10 The playing cards have the value imprint 31 twice, and appropriately that card value imprint 31 is measured that - with respect to the card delivery opening 2 - is on the right hand side of the white framing of the card 3'. Accordingly, the prism 6 has been set up on the right, as shown in Fig. 4. When drawing a card 3', the following markings of the card 3' pass over the  
15 window 11: the front edge 33 of the card 3', the unprinted long part of the white side strip of the card, the color suit symbol 32, the narrow white space between the color suit symbol 32 and the card value imprint 31, the card value imprint 31, and the back edge of the card 3'.

20 The above mentioned sensor arrangement must recognize the fact that a card 3' has been drawn and must ignite the impulse light source 5 at possibly exactly that moment when the card value imprint 31 is passing over the window 11.

25 To this end two principle methods of solution are given in the following, whereby the one requires the use of only one sensor, and the other method requires two sensors 7, 8 as indicated in Fig. 2.

30 If only one sensor is provided, per example the front and the back edges of the card are used as reference markings, whereby the sensor is situated in the card shoe 1 at any lateral position and, looking in the direction of the movement path of the card  
35 3', is placed at a defined vertical distance in front of the

window 11 in such a way that the back edge of the card will leave the sensor when the card value imprint 31 is precisely over the window 11. The mentioned sensor can be either a pressure sensor or a photoelectric barrier. When the front edge of the card touches the sensor it switches on the measuring device; when the back edge of the card leaves the sensor it activates the impulse light source 5, after which the measuring device switches off again.

10 According to the arrangement illustrated in Fig. 2, two optical electronic sensors 7, 8 are used. Sensor 7, situated further inside the card shoe 1, serves as a movement indicator for the drawn card 3' and activates the measuring device. However, the sensor 7 does not need to be as close to the window 11 as indicated in Fig. 2. The sensor 8 which lies in the path of the moving card value imprint 31 and behind the window 11, shall recognize when the card value imprint 31 is exactly over the window 11 and shall activate the light source 5.

20 According to the embodiment illustrated in Fig. 2, the sensor 8 is situated adjacent to the window 11 and in this manner registers the narrow white space between the color suit symbol 32 and the card value imprint 31. The sensor 8 can also be situated at a defined distance from the window 11 in order to detect the coming color suit symbol 32 and uses this as a reference markings to activate the lamp 5.

30 As compared to the technique using only one sensor, the advantage of the technique using two sensors 7, 8 is that this sensor 8, which is responsible for determining the exact position of the card value imprint 31 over the window 11, is fully covered by the card 3' and will thus not be disturbed by outside light, as it could happen with respect of the back edge of the card when using only one sensor, if the sensor is not a pressure sensor but a light barrier.

35

The sensor 8 switches on the impulse light source 5 without significant delay so that, as described above, the card value imprint 31, or at least a representative part thereof, is  
5 projected on the CCD-image converter 4 and the signals received are registered as the card value of the drawn card 3'.

The technical and, in particular, the electronic measures and control programs needed to realize the above processes are common  
10 for the professionals and do not require any particular explanation.

However, it should be noted that the card value recognition device (CVRD) should first "learn", on the one hand, to recognize  
15 the card values and, on the other hand, to evaluate the card values in accordance with the rules of the game. Towards this end, at a previous phase of programming the card values (the numbers 2 through 10 and the capitals A, J, Q, K) are projected into the image converter 4, and then the signals received by the  
20 image converter 4 are coded in accordance with the card value. The CCD-image converter 4, functioning as numerical camera, and the signaling and data processing system connected to it, will also be capable of identifying the "total picture" of the imprint 31 in such situations where a card 3' is drawn and the card value  
25 imprint 31 is not exactly over the window 11 when the impulse light source 5 lights up, so that only a part of the card value imprint 31 is projected in the image converter 4. This ensues from the fact that the top or bottom half, respectively, of each number or capital imprint 31 differs from any respective fragment  
30 of the other pictures of the numbers or capitals.

In gaming practice the speed by which a card 3' is drawn from the card shoe 1 will not exceed 1 m/s. Thus, based on a card movement speed of 1 m/s and a window length of 15 mm, it will take 15 ms  
35 for each image point of the card value imprint 31 of 15 mm to

pass over the window 11. With a response time of approximately 0.1 ms from the moment of registering the reference markings of the card 3' inducing the flash light until the impulse light source 5 lights up, the card value imprint 31 will lie fully or almost fully over the window 11 and will be received fully or almost fully by the CCD-image converter 4; with a lamp flash duration of about 10 microseconds a quasi-still image of the card value imprint 31 will be detected and thus a not smeared image of the card value imprint 31 will be produced on the target of the image converter 4.

When illuminating the card value imprint 31 of a card 3' with a xenon lamp at a distance of 20 mm (e.g. through the peripheral range of a deviating prism 6, as further described above) using a 500 Volt xenon lamp having an output of 0.01 W and a duration of the lamp flash of 10 microseconds, in view of the reducing effects of the color filter 17 perfect and reliable registration of the card value imprint 31 were produced, even if the speed by which the playing card is drawn exceeds 1 m/s.

The following explanation relates to a gaming table according to the invention.

According to the system for a "Black Jack" table shown in Fig. 4, detectors situated under the table cloth 51 will be used. These detectors can be based on various mechanical or physical principles, e.g. pressure-sensitive detectors (piezo sensors; tension spring sensors) or - where the chips and playing cards share similar material properties - on electromagnetic or other technical principles.

According to the invention preferably light-sensitive detectors are used, particularly photodiodes 52 in form of infra-red sensitive silicone diodes. The advantage is that these

photodiodes can detect as well chips 41 as playing cards 3 placed on the table.

5 In order not to disturb the usual external appearance of the gaming surface, the photodiodes 52 must be set up under the table cloth 51, whereby the table cloth (layout) 51 must have a certain light permeability, in particular for the near infra-red light (IR-light) coming from the artificial casino lighting.

10 In this connection the table cloth 51 should let through the IR-light of the near IR-range in an order of about 30% of the light energy falling on the table cloth. If the common material from which the table cloths 51 are made, does not permit such light permeability, it will be necessary for the purpose of the  
15 invention to choose a material that lets through sufficient light.

The detection principle is as following. All zones of the table cloth 51 on which the gaming chips and playing cards are to be  
20 placed in accordance of the gaming rules will, according to the type of game, cover an adjusted grid or an adjusted row of light detectors in such way that each object placed on the table cloth 51 (chips, playing cards) will cover, for safety reasons, at least two, and preferably three or four, of the photodiodes 52,  
25 and so will cause these photodiodes 52 excluded from receiving light to work in the sense of the operating system.

As per Fig. 4, a geometrical grid of photodiodes 52 is placed under each rectangular box 53, while for the other zones of the  
30 gaming surface of the table cloth 51 photodiodes 52 are laid out in rows, so under the insurance lines 54, under the layout areas 55 for the cards of the players and under the layout area 56 for the cards of the dealer.

According to the embodiment shown in Fig. 4, seven rows of photodiodes 52 of five diodes each have been set up for the boxes 53 in such way that the two outer rows are positioned outside of the box marking 53 printed on the table cloth 51.

5

A row of four photodiodes 52 is positioned under each insurance line 54; however, more diodes 52 or a double row of diodes can also be positioned here.

10

In the example illustrated in Fig. 4, in accordance with the normal measurements of a "Black Jack" table and the boxes 53 and insurance lines 54, the photodiodes under each box are spaced 19 mm apart, while there is a distance of 15 mm between each row of diodes, so that a gaming chip of e.g. 40 mm in diameter will cover in the most unfavorable situation four diodes and in the most favorable situation five diodes. Although the dimming effect may be incomplete for those photodiodes which were only covered by the edge of the chip because of the stray light falling over the edge of the chip, a minimum of two diodes will have been optimally covered. For the rest, it should be assumed that even to the optimally darkened photodiodes falls still about 10% of the light energy which has passed through the table cloth 51 so that the sensitivity of the photodiodes 52 must be adjusted to this only achievable brighter-darker effect.

20

25 In accordance with the stacked position of the playing cards shown with respect of the box 53.7, the distances between the photodiodes 52 should be smaller, e.g. 7 mm, while for the registration of the cards of the dealer, which are not overlapping but will be placed next to each other, a distance of 30 25 mm between the photodiodes should be sufficient, that each card will cover at least two photodiodes.

As to the boxes 53 there are shown different positions for placing chips 41 as "Box", "Double Down", "Split", and "Insurance".

5 The explanations given above for the covering of the photodiodes 52 by chips 41 are basically the same for the playing cards 3 that have been laid out.

10 In the result, the signals coming from the photodiodes 52 are to be processed as a batch or separately in such way that the electronic switching logic can recognize multiple stakes of chips 41 in a box 53 and further the number of cards placed in front of each player, including where there is a second row of cards ("Split"); it must also process the shifting or adjustment of the  
15 chips or cards in accordance with the variations of "Double Down", "Split" and "Insurance".

The given disclosure of the technical principle will enable the experts, such as technical designers, electrical engineers and  
20 computer programmers, to realize a gaming table in accordance with the invention, including the integration of automatic control systems for adjusting the sensitivity of the photodiodes for changes in brightness in the gaming room, for example, when switching additional lamps on or off.

25 Overmore the professionals involved in setting up the system may, on the basis of economic considerations and depending on the desired functional reliability of the system, deviate from the above values for fitting the photodiodes 52 of the various  
30 playing areas (boxes, insurance lines, card fields).

To complete the gaming table device in the sense of a gaming equipment which operates as fully automatically as possible, a switching key (not shown) is provided which will be activated by  
35 the dealer after the stakes have been placed, and signaling

switches 57 or similar are provided for the players which the players can use to indicate not to wish to receive any more cards.

5 The following explanations relates to the principles and devices for determining the value of the gaming chips (jettons) placed as a stake and for determining the total value of the stake, when there is a stack of chips (Stake Detector).

10 At "Black Jack" tables usually so called "American Chips" are used; they are distinguished in their different values by different colors. Depending on the "table maximum bet" (limit of bet per game) only three or four different denominations and colors of chips will be used per table.

15 The bets are automatically registered per example by a hand-held device operated by the dealer which functions as a television camera or scanner. The camera or scanner registers separately the chip or the stack of chips placed by each player; the image  
20 received by the camera or scanner is analyzed for it's value, noting the color of the chips and the number of chips of the same color. The total value of the checked stake is then transmitted to the EDP unit. If the chips have graphic signs and marks around their edges, which can also represent the value of the chip, then  
25 the scanning of the stake will be even easier.

Furthermore, so called "Smart Chips" can be used. These smart chips, also known as "High Security Chips", have integrated electronic components functioning without a battery and acting as  
30 transponder for a radio frequency identification system (RFID system), whereby the transponder can interact with a transmitting and receiving device (arranged under the table for example) and transmit a specific signal which corresponds to their value.

The RFID system is as follows: there is a contactless inductive data transmission system that provides bi-directional signal transfer between sending- and receiving (S/R) station and one or more batteryless transponders.

5

The communication between the S/R station is achieved by means of inductive antennas. From the S/R station to the transponder data and energy are transmitted whereas from the transponder to the S/R station only data is transmitted.

10

The transponder has an antenna circuit or network which is formed by one or more coils for wireless inductive signal transfer. The coil is connected to a single chip which contains all necessary equipments for receiving, recovering and transmitting a signal from or to the sending and receiving station. Additionally the chip contains a data storage or memory.

15

The sending and receiving station which comprises an oscillator capable of generating a high frequency signal for the simultaneous transmission of energy, clock and information to the transponder. The station also includes demodulator and modulator, a control unit and interfaces.

20

When applying the RFID-System on the casino-chips with transponder (in the following referred to as transponder-jettons) the S/R station comprises an electronical read/write unit and is wired up with several coils as inductive antennas for the signal transfer to and from the transponder-jetton whereby to each box (including its insurance line) of the gaming table such an inductive antenna (loop antenna) for the communication of the S/R station with transponder-jettons placed on the box is designated.

30

The gaming-value of the jetton is stored in the memory of the chip of the transponder.

The read/write unit supports a special anti-collision algorithm which allows to operate and identify the different transponder-jettons, at the same time within the antenna field of the  
5 read/write unit.

All transponder-jettons within the antenna field lie parallel to the table and have to be stacked up. The read/write unit selects and identifies the electronic unit, included in the jetton. The  
10 recorded data can be transmitted via a interface of the read/write unit to a connected host.

If a stake detector operating according to one of the methods as described above is not available, then as in the past the dealer  
15 can determine the bet and can enter the information into the calculation and evaluation system through the data entry device.

The following explanations relate to the total gaming equipment according to the invention.

20 The data registered for each functional technical unit - inter alia, the card value recognition device of the card shoe 1, the gaming chip and playing card registration devices of the gaming table, and the gaming bet detector (camera or scanner; RFID  
25 system), or the manually operated data entry device, respectively, for the values of the gaming bets - are to be transferred as output signals to a central computer, either directly or indirectly. This transmission of the output signals can be made either by cable connection or wireless, e.g., by data  
30 radio. Thus, the arrangement 18 shown in Fig. 1 represents either a cable connection or a transmitter for the transmission of the signals coming from the CCD-image converter 4.

The central computer has the task of evaluating the total of  
35 registered data in accordance with the EDP program, to show same

to the dealer, if do desired, on a monitor or some such, and in  
general to store the data for further use. In any case, in the  
game of "Black Jack" it should be avoided that the dealer will be  
informed of the value of his second card (face down) until this  
5 card has been turned face up in the regular way of the game; this  
is to prevent opening up a new source for the dealer for the  
possibility of improper actions favoring any particular player.

The gained gaming data can furthermore be used for audio or  
10 optical signals, e.g., when the dealer has made a mistake, or the  
cards have not been dealt in the proper sequence or if the card  
shoe needs to be refilled with other decks of cards. Further the  
stored data can be used for judgment of the dealer's and players'  
performance, for evaluation of daily rounds, for statistical  
15 purposes, to link some or all gaming tables of one or more  
casinos or, in the case of other games then "Black Jack", for  
cumulative jackpot systems of one or more gaming tables.

However, a gaming equipment according to the invention is not  
20 able to check and monitor automatically the wins according to the  
gaming rules for correct payment by the dealer. But, in view of  
the settlement of table results (win or loss) between the dealer  
and the casino, which can be determined by the EDP program now,  
this will not be particularly significant.

List of reference signs

- |    |    |                                    |
|----|----|------------------------------------|
|    | 1  | card slide (card shoe)             |
| 5  | 2  | card delivery                      |
|    | 3  | playing card                       |
|    | 3' | playing card (being drawn)         |
|    | 4  | CCD-image converter                |
|    | 5  | light impulse source               |
| 10 | 6  | deviating prism                    |
|    | 7  | sensor (card shoe)                 |
|    | 8  | sensor (card shoe)                 |
|    | 9  | slant or support                   |
|    | 10 | sliding wedge                      |
| 15 | 11 | window                             |
|    | 12 | mirror plane (prism)               |
|    | 13 | window plane (prism)               |
|    | 14 | exit plane (prism)                 |
|    | 15 | lens                               |
| 20 | 16 | light path                         |
|    | 17 | red light filter                   |
|    | 18 | connection/transmitter             |
|    | 31 | card value imprint                 |
|    | 32 | color suit symbol                  |
| 25 | 33 | transverse side (playing card)     |
|    | 41 | gaming chip, jetton                |
|    | 51 | table cloth (layout)               |
|    | 52 | sensor, photodiode (gaming table)  |
|    | 53 | box                                |
| 30 | 54 | insurance line                     |
|    | 55 | place for placing cards (player's) |
|    | 56 | place for placing cards (dealer's) |
|    | 57 | signaling switch                   |

THE EMBODIMENTS OF THE INVENTION IN WHICH AN EXCLUSIVE PROPERTY OR PRIVILEGE IS CLAIMED ARE DEFINED AS FOLLOWS:

1. A gaming equipment for professional use of games of chance using playing cards (3) and gaming chips (jettons (41)), in particular for the game of "Black Jack", comprising a gaming table with gaming table cloth (layout (51)), and, designated on this cloth (51), betting boxes (53) and possibly further areas for placement of jettons (41), and areas for placement of the playing cards (3)
  - and a card shoe to store a stack of playing cards (3), whereby the card shoe has the function of a card dispenser for drawing out the playing cards (3') face down (picture side down), characterized in that in order to automatically register, evaluate, display and store the results and data of the run of the game,
    - the card shoe (1) is equipped with a card recognition device to register the card value imprint (31) of the drawn card (3'), whereby the card value imprint (31) of all cards (3) is located at the same defined position,
    - the gaming table under its table cloth (51) has occupation detector units consisting of a multiple number of single detectors, whereby the occupation detector units are provided to register the number of the jettons (41) and playing cards (3) placed directly on the table cloth (51) at the respective gaming table areas (53, 54; 55, 56),  
and whereby such an occupation detector unit is allocated to each box (33), to each area (54) for the placement of jettons (41), and to each area (55, 56) for the placement of playing cards (3),
    - a gaming bet detector is provided acting as an automatic recognition unit to register the gaming bets, or, alternatively, is provided a device for the manual input of the gaming bets,
    - there are provided a computer and an EDP program created according to the gaming rules, designated to evaluate the

signals transmitted to the computer from the card value  
recognition unit, from the occupation detector units, from the  
gaming bet recognition unit or the manual gaming bet input  
device, respectively, and, possibly, from further signal  
5 transmitters (57),

- and a monitoring device is provided, preferably a display unit,  
to display the from the computer coming evaluated data related  
to the run of the game.

10 2. Gaming equipment according to claim 1, characterized in that  
the card shoe (1) comprises:

- an optical window (11) placed in the movement track of the card  
image imprint (31) of the drawn card (3'),

- an optical device to depict in a CCD-image converter (4) that  
15 part of the picture side of the card (3'), which is positioned  
over the window (11), whereby the optical device includes a  
deviating device to transmit the reflected image of the card  
imprint value (31) over an optical path into the CCD-image  
converter, a red light filter (17) situated in the light path  
20 (16) from the deviating device to the image converter (4), and  
an impulse light source (5) to illuminate that part of the card  
(3') which is over the window (11),

- and a sensor device to determine the movement of the drawn card  
(3'), to switch the measuring device (5, 4) of the card value  
25 recognition unit into standby for measuring, and to determine  
the correct timing of lightning of the impulse light source (5)  
at that moment when the card value imprint (31) of the drawn  
card (3') is exactly over the window (11).

30 3. Gaming equipment according to claim 2, characterized in that  
as the deviating device to depict in the CCD-image converter (4)  
that part of the picture side of the card (3') which is  
positioned over the window (11), there is provided a deviating  
optical prism (6) positioned below the window (11), whereby the  
35 one plane (13) of the prism (6) forming the right angle covers

the window (11) and the other plane (12) forming the right angle looks towards the CCD-image converter (4), and that the impulse light source (5) is arranged behind the mirror plane (12) to illuminate through the prism (6) that part of the picture side of the card (3') which is positioned over the window (11).

4. Gaming equipment according to claim 2, characterized in that as the deviating device to depict in the CCD-image converter (4) that part of the picture side of the card (3') which is positioned over the window (11), a mirror is provided, whereby the impulse light source (5) is arranged in front of the mirror.

5. Gaming equipment according to one of claims 2 to 4, characterized in that the sensor device of the card shoe (1) has a single sensor having the function, by way of sensing the front edge (33) of the card (3') first to determine that the card (3) is being drawn and to activate the measuring device and then to light up the impulse light source (5) at the moment when the back edge of the card is going past.

6. Gaming equipment according to claim 5, characterized in that the sensor of the card shoe (1) is either a pressure sensor or a photoelectric barrier.

7. Gaming equipment according to one of claims 2 to 4, characterized in that the sensor device of the card shoe (1) includes two optoelectronic sensors (7, 8), whereby the one sensor (7) is located outside of the movement track of the card value imprint (31) to be recognized and serves as a movement sensor to activate the measuring device, and the other sensor (8) is situated in the movement track of the card value imprint (31) behind the window (11) and activates the impulse light source (5) by sensing a color trigger (printed or colorless area) at that moment when the card value imprint (31) is passing over the window (11).

8. Gaming equipment according to one of claims 2 to 7, characterized by a xenon lamp as the impulse light source (5) of the card shoe (1).

5

9. Gaming equipment according to claim 1, characterized in that the single detectors of the occupation detector units of the gaming table are light-sensitive sensors (52) to register the light coming through the table cloth (51) depending on the arrangement of the jettons (41) and the playing cards (3) over the sensors (52).

10

10. Gaming equipment according to claim 9, characterized by IR-light-sensitive photodiodes, in particular silicium diodes, as the light-sensitive sensors of an occupation detector unit of the gaming table.

15

11. Gaming equipment according to claim 9 or 10, characterized by a geometrical arrangement of the sensors (52) of a betting occupation detector unit in between each other, so that each object (jetton, playing card) which is placed on the table cloth (51) in accordance with the gaming rules, will best possibly cover at least two sensors (52).

20

25

12. Gaming equipment according to claim 1, characterized in that the gaming bet detector for automatic recognition of the bet being placed either as a single jetton (41) or as a stack of jettons (41) - whereby jettons (41) are used having different colors in accordance with their gaming value and, optionally, having colored markings around their edge, whereby the colored markings also are or may be representative for the value of the jetton - is a scanner which can discriminate the color and the number of jettons of same color.

30

35

13. Gaming equipment according to claim 1, characterized in that  
as the gaming bet detector for automatic detection and  
registration of the bet placed in form of jettons, a radio  
frequency identification (RFID) system is used, and for that  
5 purpose there is provided a transmitting and receiving station  
(S/R station) and jettons with integrated transponder, whereby  
S/R station and transponder interact in such a way that as a  
response to the high frequency signals of the S/R station the  
transponder transmits back to the S/R station data which are  
10 characteristic for the value of the jetton and will be evaluated  
in the S/R station.

14. Gaming equipment according to claim 1, optionally in the  
form of the card shoe (1) according to one of claims 2 to 8, of  
15 the gaming table according to one of claims 9 to 11 and of the  
gaming bet detector according to claim 12 or 13, characterized in  
that the functional units of the equipment are connected by way  
of cable connection, or wireless by radio data transmission and  
reception devices, to the computer which collects, evaluates,  
20 stores and displays the data.

Fetherstonhaugh & Co.,  
Ottawa, Canada  
Patent Agents

