

(12) STANDARD PATENT
(19) AUSTRALIAN PATENT OFFICE

(11) Application No. **AU 2008229405 B2**

- (54) Title
Method and apparatus for high speed downlink packet access link adaptation
- (51) International Patent Classification(s)
H04L 12/56 (2006.01)
- (21) Application No: **2008229405** (22) Date of Filing: **2008.03.14**
- (87) WIPO No: **WO08/115452**
- (30) Priority Data
- (31) Number (32) Date (33) Country
60/895,385 **2007.03.16** **US**
- (43) Publication Date: **2008.09.25**
(44) Accepted Journal Date: **2010.11.11**
- (71) Applicant(s)
InterDigital Technology Corporation
- (72) Inventor(s)
Marinier, Paul;Cave, Christopher R.;Digirolamo, Rocco
- (74) Agent / Attorney
Watermark Patent and Trade Marks Attorneys, Level 2 302 Burwood Road, Hawthorn, VIC, 3122
- (56) Related Art
US 2005/023941 A1
EP 11511247 A2 == US 7539207 B2 == US 2005/0047387 A1
US 2007/0254679 A1
3GPP TS 25.215 v7.1.0 (2006-09)
EP 1720373 A1 == US 2006/0252377 A1
3GPP TS 25.308 v7.2.0 (2007-03)

(19) World Intellectual Property Organization
International Bureau



(43) International Publication Date
25 September 2008 (25.09.2008)

PCT

(10) International Publication Number
WO 2008/115452 A3

(51) International Patent Classification:
H04L 12/56 (2006.01)

Brossard, Québec J4X 2J7 (CA). **CAVE, Christopher, R.** [CA/CA]; 201 chemin du Golf, Apt. 304, Ile-des-soeurs (Verdun), Québec H3E 1Z4 (CA).

(21) International Application Number:
PCT/US2008/003463

(74) Agent: **BALLARINI, Robert, J.**; Volpe and Koenig, P.C., United Plaza, Suite 1600, 30 South 17th Street, Philadelphia, PA 19103 (US).

(22) International Filing Date: 14 March 2008 (14.03.2008)

(25) Filing Language: English

(81) Designated States (unless otherwise indicated, for every kind of national protection available): AE, AG, AL, AM, AO, AT, AU, AZ, BA, BB, BG, BH, BR, BW, BY, BZ, CA, CH, CN, CO, CR, CU, CZ, DE, DK, DM, DO, DZ, EC, EE, EG, ES, FI, GB, GD, GE, GH, GM, GT, HN, HR, HU, ID, IL, IN, IS, JP, KE, KG, KM, KN, KP, KR, KZ, LA, LC, LK, LR, LS, LT, LU, LY, MA, MD, ME, MG, MK, MN, MW, MX, MY, MZ, NA, NG, NI, NO, NZ, OM, PG, PH, PL, PT, RO, RS, RU, SC, SD, SE, SG, SK, SL, SM, SV, SY, TJ, TM, TN, TR, TT, TZ, UA, UG, US, UZ, VC, VN, ZA, ZM, ZW.

(26) Publication Language: English

(30) Priority Data:
60/895,385 16 March 2007 (16.03.2007) US

(71) Applicant (for all designated States except US): **INTER-DIGITAL TECHNOLOGY CORPORATION** [US/US]; 3411 Silverside Road, Concord Plaza, Suite 105, Hagley Building, Wilmington, Delaware 19810 (US).

(72) Inventors; and

(84) Designated States (unless otherwise indicated, for every kind of regional protection available): ARIPO (BW, GH, GM, KE, LS, MW, MZ, NA, SD, SL, SZ, TZ, UG, ZM, ZW), Eurasian (AM, AZ, BY, KG, KZ, MD, RU, TJ, TM),

(75) Inventors/Applicants (for US only): **DIGIROLAMO, Rocco** [CA/CA]; 632 Fribourg Street, Laval, Québec H7K 3Y3 (CA). **MARINIER, Paul** [CA/CA]; 1805 Stravinski,

[Continued on next page]

(54) Title: METHOD AND APPARATUS FOR HIGH SPEED DOWNLINK PACKET ACCESS LINK ADAPTATION

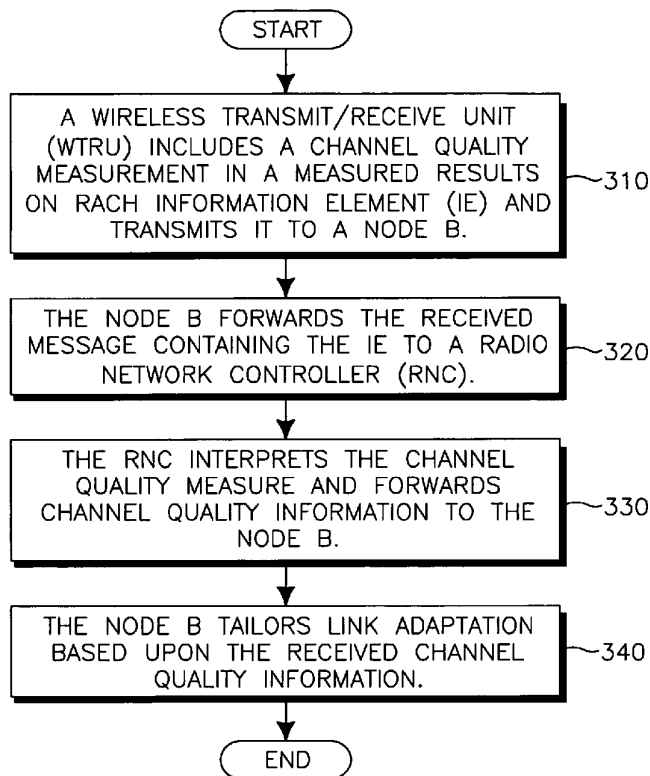

(57) Abstract: A method of high speed downlink packet access (HSDPA) link adaptation, comprises receiving at a Node B a channel quality measurement metric over a Measured Results on random access channel (RACH) information element (IE). The link is adapted based upon the received channel quality metric. In addition, a corresponding method at a WTRU is disclosed comprising performing a channel quality metric measurement and transmitting the channel quality metric measurement over a Measured Results on RACH IE to the Node B.

FIG.3

WO 2008/115452 A3



European (AT, BE, BG, CH, CY, CZ, DE, DK, EE, ES, FI, FR, GB, GR, HR, HU, IE, IS, IT, LT, LU, LV, MC, MT, NL, NO, PL, PT, RO, SE, SI, SK, TR), OAPI (BF, BJ, CF, CG, CI, CM, GA, GN, GQ, GW, ML, MR, NE, SN, TD, TG).

— *before the expiration of the time limit for amending the claims and to be republished in the event of receipt of amendments*

Published:

— *with international search report*

(88) Date of publication of the international search report:

18 December 2008

[0001] METHOD AND APPARATUS FOR HIGH SPEED DOWNLINK
PACKET ACCESS LINK ADAPTATION

[0002] FIELD OF INVENTION

[0003] This application is related to wireless communications.

[0004] BACKGROUND

[0005] High Speed Downlink Packet Access (HSDPA) is a feature that was introduced in Release 5 of the third generation partnership project (3GPP) specifications to operate in a cell dedicated channel (Cell_DCH) state. A key operating principle of HSDPA is to share a very fast downlink (DL) pipe, the high-speed downlink physical shared channel (HS-DPSCH). A universal terrestrial radio access network (UTRAN) can configure up to 15 HS-DPSCHs, and each of these can be shared by all wireless transmit/receive units (WTRUs) on a per transmission time interval (TTI) basis, (i.e., every 2 msec). As a result, the information on the downlink channels can be destined to different WTRUs at an interval of every 2 msec. In order to allow WTRUs to determine ownership of the information on these shared channels, a Node-B also sends a set of parallel high speed shared control channels (HS-SCCHs). Among other things, these channels provide details allowing the WTRUs to determine if the information on the HS-DPSCH is for them, and if so, to recover the transmitted information.

[0006] In HSDPA, the Node-B tries to make a better use of the downlink capacity by using several concepts, such as adaptive modulation and coding (AMC), retransmissions using a hybrid automatic repeat request (H-ARQ) scheme, and Node-B scheduling. All of these operate at a very fast rate, directed toward taking advantage of the changing channel conditions perceived by the WTRUs. In order to accomplish this, the Node-B schedules transmissions in order to maximize downlink throughput, (e.g., using 16-quadrature amplitude modulation (QAM) for a WTRU very close to the Node-B and using quadrature phase shift keying (QPSK) for a WTRU at cell edge). This fast scheduling is complemented with H-ARQ at a physical layer, allowing retransmission of

transport blocks that are received in error. Furthermore, multiple simultaneous H-ARQ processes are permitted in order to maximize utilization.

[0007] Every 2 msec, the Node-B schedules transmissions on the HS-DPSCH based on WTRU channel conditions, the status of its own downlink buffers, and status of the parallel H-ARQ processes. In addition, the Node-B tailors the transmission bit rates to the specific WTRUs by adapting the modulation, coding, and transport block size. To achieve this, the Node-B requires the following information from the WTRUs:

- Channel Quality Indication (CQI): an index into a table which provides the maximum MCS and transport block the WTRU can support, based on the received DL signal power, the interference from other cells, and the WTRU receiver capability; and
- Positive acknowledgement (ACK)/negative acknowledgement (NACK) feedback for the H-ARQ processes.

[0008] This feedback information is provided on a high speed dedicated physical control channel (HS-DPCCH). The CQI information is provided periodically, with periodicity determined by the UTRAN. The ACK/NACK information is only provided in response to a packet being received on the downlink. Some of the main attributes of the HS-DPCCH include:

- Every WTRU having an access to the HSPDA has its own dedicated control channel and as a result the WTRU can easily provide the feedback information;
- The channel is power controlled; this is accomplished through a closed loop mechanism using the downlink dedicated physical control channel (DPCCH), which always accompanies HSDPA transmission;
- The information on the HS-DPCCH is heavily coded to aid in detection; and
- The information on the HS-DPCCH is time aligned (but delayed) with respect to the UL DPCCH.

[0009] As part of Release 7 of 3GPP, using the high speed shared channel for WTRUs in a Cell_FACH state has been considered. The properties of a WTRU

in a Cell_FACH state are quite different from those for a WTRU in a Cell_DCH state including the following:

- The only uplink mechanism for Release 7 WTRUs in a Cell_FACH state is through a random access mechanism, over the random access channel (RACH);
- The WTRUs autonomously update the UTRAN as to their cell location through CELL UPDATE and URA UPDATE procedures;
- The WTRU can be configured for forward access channel (FACH) measurement occasions – these are periods during which the WTRU takes measurements on inter-radio access technology (RAT) and/or inter-frequency cells;
- The WTRUs make the following physical layer measurements:
 - common pilot channel (CPICH) received signal code power (RSCP): The received signal code power measured on the primary CPICH; and
 - CPICH E_c/N_0 : The received energy per chip divided by the power density in the band. The CPICH E_c/N_0 is defined as CPICH RSCP/UTRA Carrier received signal strength indicator (RSSI). The UTRA Carrier RSSI is not measured in Cell_FACH, but only in Cell_DCH. It is the received wide band power, including thermal noise and noise generated in the receiver, within the bandwidth defined by the receiver pulse shaping filter; and
- Physical layer measurements are reported to the UTRAN via layer 3 signalling through the Measured Results on RACH mechanism.

[0010] The measured results on RACH mechanism are designed to provide some feedback information to the UTRAN regarding the current state of the downlink. The mechanism may be controlled by the network, which broadcasts, as part of its system information in system information block 11 (SIB11) and SIB12, the information element (IE) "Intra-frequency reporting quantity for RACH Reporting". This IE tells all WTRUs in the cell the quantity to measure. The choices are highlighted in Table 1 below, along with the granularity of the reported quantity and the length of the coded information sent to the UTRAN.

Quantity	Determined by/from	Granularity	Size of Coded Information
CPICH RSCP	as measured by PHY layer	-120 to -25 dBm (in steps 1 dBm)	7
CPICH Ec/No	as measured by PHY layer	-24 dB to 0 dB (in steps of 0.5 dB)	6
Pathloss	Pathloss in dB = Primary CPICH Tx power - CPICH RSCP. Where Primary CPICH Tx power is found in the IE "Primary CPICH Tx power", and CPICH RSCP is as measured in PHY layer	46 to 158 dB (in steps of 1 dB)	7
No report			0

Table 1

[0011] Referring to Table 1 above, a WTRU takes the appropriate measurements and reports these to the higher layers, (e.g., radio resource control (RRC)). In a Cell_FACH state, the base measurement period is 200 msec, but this can be higher if a FACH Measurement Occasion is configured for monitoring inter-frequency and inter-RAT cells. The accuracy of the measurement is defined to be ± 6 dB for the current cell.

[0012] The information is sent to higher layers to be included in the IE "Measured results on RACH", in a number of RRC messages including: CELL UPDATE, RRC CONNECTION REQUEST, INITIAL DIRECT TRANSFER, UPLINK DIRECT TRANSFER, and MEASUREMENT REPORT messages. Unlike the majority of other measurements and quantities available at the RRC, those carried in the IE "Measured results on RACH" can not be filtered by the RRC prior to transmission.

[0013] The IE contains the configured measured quantity for the current cell and all other intra-frequency cells in the monitored set (the monitored set includes a list of cells that the UTRAN has told the WTRU to monitor). The IE may also contain the configured measured quantity for inter-frequency cells.

[0014] For RRC messages transmitted on a common control channel (CCCH), the maximum allowed message size should not be exceeded when

forming the IE "Measured results on RACH". To achieve this, the WTRU may limit the number of included neighbor cells included in the report, or omit the IE "Measured results on RACH" altogether.

[0015] If HSDPA is to be used in a Cell_FACH state, the main problem is the lack of a dedicated uplink channel and the resulting absence of feedback. Without this information, the advantages of HSDPA are significantly reduced.

[0016] Several proposals addressed to solve the feedback issue have already been made. In one proposal, it has been proposed to transmit CQI information over:

- The RACH transport channel either in preamble or message;
- A new shared common uplink channels; and
- Shared uplink code space.

[0017] However, the techniques described above require changes to the WTRU physical layer. As there is a strong push to limit these changes, it has been proposed to use the "Measured Results on RACH" mechanism to transmit channel quality information to the UTRAN. As the information is embedded in an RRC message IE, the UTRAN radio network controller (RNC) would need to forward the channel quality information to the Node-B so that it may perform its adaptive modulation and coding.

[0018] Using the "Measured Results on RACH" mechanism to provide channel quality feedback has a number of problems, however. For example:

1. The measured quantity (metric) that is fed back and subsequently used by the Node-B is either CPICH RSCP or CPICH Ec/No. Problems that may be associated with both these measures include:

1) RSCP only measures received power on a single code and does not provide any indication about the neighbour cell interference experienced by the WTRU.

2) Ec/No provides a ratio of the power received on the CPICH to the total received downlink power ($CPICH\ Ec/No = CPICH\ RSCP/UTRA\ Carrier\ RSSI$). As the denominator is the total received DL power, the range of the metric is somewhat reduced compared to a pure carrier/interference ratio.

Additionally, the downlink received power (i.e., RSSI) is not necessarily measured in the Cell_FACH state. If it is not, then when making a CPICH Ec/No calculation, the physical layer uses the last calculated RSSI value while in Cell_DCH state. If a UE stays in Cell_FACH for an extended period of time, this value will be outdated, and the measure will be no better than the CPICH RSCP.

3) These measures fail to take into account the WTRU receiver capability. It is possible that for the same CPICH RSCP, WTRUs with different receiver architectures could support very different modulation, coding, and transport block sizes.

4) There is poor correlation between the RSCP and Ec/No and the actual CQI.

2. As WTRUs in Cell_PCH move across cell boundaries, the UTRAN refreshes their channel quality information based on information received in the CELL UPDATE message. If these WTRUs transition to Cell_FACH, the UTRAN will have up-to-date channel quality information which it can relay to the Node-B. On the other hand, as WTRUs in URA_PCH cross UTRAN routing area (URA) boundaries, they inform the network with a URA UPDATE message. As this message does not carry the IE "Measured Results on RACH", the network will typically have out-of-date channel quality information.

3. The quantities reported in the IE: "Measured Results on RACH" cannot be filtered at the WTRU RRC. As there is a latency between the instant the measurement is made and the time the Node-B is privy to this information, using non-averaged results may result in sub-optimum performance.

4. The Measured Results on RACH mechanism is currently controlled on a per-cell basis through information broadcast in the system information. As a result, all WTRUs in a cell are required to report the same information. This limits the flexibility of the reporting mechanism as the UTRAN may favor one measure over the other depending on the eventual use. For instance, the pathloss may be a better measure for cell reselection, but the CPICH Ec/No may be better for channel quality reporting.

SUMMARY OF THE INVENTION

A method and apparatus for high speed downlink packet access link adaptation is disclosed. The method includes receiving a channel quality measurement metric over a Measured Results on random access channel (RACH) information element (IE). A link is adapted based upon the received channel quality metric.

In one aspect the present invention provides a method of high speed downlink packet access (HSDPA) link adaptation, including:

performing a channel quality metric measurement, in a state that a wireless transmit/receive unit (WTRU) does not have a dedicated link, in synchronization with a WTRU discontinuous reception (DRX) cycle; and

transmitting the channel quality metric measurement over a Measured Results on random access channel (RACH) information element (IE).

In another aspect the present invention provides a wireless transmit/receive unit (WTRU), including:

a receiver;

a transmitter; and

a processor in communication with the receiver and the transmitter, the processor configured to performing a channel quality metric measurement, in a state that the WTRU does not have a dedicated link, in synchronization with a WTRU discontinuous reception (DRX) cycle, and transmit the channel quality metric measurement over a Measured Results on random access channel (RACH) information element (IE).

BRIEF DESCRIPTION OF THE DRAWINGS

A more detailed understanding may be had from the following description, given by way of example in conjunction with the accompanying drawings wherein:

Figure 1 shows an example wireless communication system including a plurality of WTRUs, a radio network controller (RNC), and a Node B; [0024J

Figure 2 is an example functional block diagram of a WTRU and the Node B of Figure 1; and

Figure 3 is a flow diagram of a method of HSDP A link adaptation.

DETAILED DESCRIPTION

When referred to hereafter, the terminology "wireless transmit/receive unit (WTRU)" includes but is not limited to a user equipment (UE), a mobile station, a fixed or mobile subscriber unit, a pager, a cellular telephone, a personal digital assistant (PDA), a computer, or any other type of user device capable of operating in a wireless environment. When referred to hereafter, the terminology "base station" includes but is not limited to a Node-B, a site controller, an access point (AP), or any other type of interfacing device capable of operating in a wireless environment.

Figure 1 shows a wireless communication system 100 including a plurality of WTRUs 110 and a Node B 120. As shown in Figure 1, the WTRUs 110 are in communication with the Node B 120. It should be noted that, although an example configuration of WTRUs 110 and Node B 120 is depicted in Figure 1, any combination of wireless and wired devices may be included in the

wireless communication system 100. In addition, an RNC 130 is in communication with the Node B 120.

[0029] Figure 2 is a functional block diagram 200 of a WTRU 110 and the Node B 120 of the wireless communication system 100 of Figure 1. As shown in Figure 2, the WTRU 110 is in communication with the Node B 120. The Node B 120 is configured to tailor HSDPA link adaptation, and the WTRU 110 provides channel quality feedback, (e.g., in the IE "Measured Results on RACH"), to aid the Node B 120 in performing link adaptation.

[0030] In addition to the components that may be found in a typical WTRU, the WTRU 110 includes a processor 115, a receiver 116, a transmitter 117, and an antenna 118. The receiver 116 and the transmitter 117 are in communication with the processor 115. The antenna 118 is in communication with both the receiver 116 and the transmitter 117 to facilitate the transmission and reception of wireless data.

[0031] In addition to the components that may be found in a typical Node B, the Node B 120 includes a processor 125, a receiver 126, a transmitter 127, and an antenna 128. The processor 125 is configured to perform a method of HSDPA link adaptation. The receiver 126 and the transmitter 127 are in communication with the processor 125. The antenna 128 is in communication with both the receiver 126 and the transmitter 127 to facilitate the transmission and reception of wireless data.

[0032] Figure 3 is a flow diagram of a method 300 of HSDPA link adaptation. In step 310, the WTRU 110 includes a channel quality measurement metric in a Measured Results on RACH IE and transmits the channel quality measurement metric to the Node B 120. In one example, the channel quality measurement metric is included in radio resource controller (RRC) signalling.

[0033] The channel quality measurement metric that the WTRU 110 transmits may include a CPICH C/I based on parameters calculated in Cell_FACH, Cell_PCH, URA_PCH, and Idle states. For instance, the following may be defined:

CPICH C/I = CPICH RSCP/(UTRA Carrier RSSI - CPICH RSCP), Equation (1)

where all units are in W. Additionally, a new measure may be defined taking into account the received signal code power, the total interference, and the WTRUs 110 capability.

[0034] Alternatively, existing measurements to the WTRU 110 channel quality measurement metrics may be modified and reported over the Measured Results on RACH IE. For example, the WTRU 110 calculated CQI may be forwarded to the higher layers as a measurement quantity and reported over the Measured Results on RACH IE or UTRA Carrier RSSI may be measured in the Cell_FACH state in order to improve the relevance of the CPICH Ec/No measure.

[0035] The Measured Results on RACH IE may be configured per WTRU 110 instead of per cell. Additionally, The WTRU 110 may send one or more channel quality metrics in the IE. The WTRU 110 may give priority to certain metrics. For example, for CCCH traffic, such as a CELL UPDATE message after a cell reselection, priority may be given the channel quality measurements that can aid link adaptation. Layer 3 filtering may also occur for any of the physical layer measurements described above.

[0036] Once the Node B 120 receives the message containing the IE, it forwards it to the RNC 130 (step 320) where the RNC interprets the channel quality measurement metric and forwards channel quality information back to the Node B 120 (step 330). The Node B may then tailor link adaptation based upon the channel quality information (step 340). Additionally, the Node B 120 may tailor the link adaptation based upon the type of filtering allowed for the WTRU 110 reported channel measure.

[0037] Additionally, in order to address WTRUs 110 that are in URA_PCH and subsequently transitioning to Cell_FACH, the Measured Results on RACH IE may be included in the URA UPDATE message. As neighboring cell measurements have less relevance in URA_PCH, the WTRU 110 may be hardcoded to only report measurement quantities based on the current cell, whether it be an existing measurement or a new measurement.

[0038] Any of the measurements that are reported by the WTRU 110, existing or new, may be synchronized with the WTRUs 110 FACH Measurement

Occasions and/or any discontinuous reception (DRX) cycle currently defined in Cell_FACH state, Cell_PCH state, URA_PCH state or idle mode, This can be achieved by matching the measurement period to a multiple of the DRX cycle.

[0039] Alternatively, synchronization may be achieved by WTRU 110 measuring the reported quantity at the next opportunity provided by the DRX cycle following the expiration of the measurement period. For instance, if the measurement period is set to 300 ms, while the DRX cycle repeats itself every 200 ms, and if the last measurement took place during the last opportunity provided by the DRX cycle ($t = 0$ ms), the WTRU 110 would measure at $t = 400$ ms instead of $t = 300$ ms.

[0040] In addition, the list of RRC messages that include the IE "Measured Results on RACH" may be expanded. For example, the IE may be included in any of the following messages: UE CAPABILITY INFORMATION, COUNTER CHECK, RADIO BEARER SETUP COMPLETE, TRANSPORT CHANNEL RECONFIGURATION COMPLETE, PHYSICAL CHANNEL RECONFIGURATION COMPLETE, UTRAN MOBILITY INFORMATION CONFIRM, or any other messages.

[0041] Although features and elements are described above in particular combinations, each feature or element can be used alone without the other features and elements or in various combinations with or without other features and elements. The methods or flow charts provided herein may be implemented in a computer program, software, or firmware incorporated in a computer-readable storage medium for execution by a general purpose computer or a processor. Examples of computer-readable storage mediums include a read only memory (ROM), a random access memory (RAM), a register, cache memory, semiconductor memory devices, magnetic media such as internal hard disks and removable disks, magneto-optical media, and optical media such as CD-ROM disks, and digital versatile disks (DVDs).

[0042] Suitable processors include, by way of example, a general purpose processor, a special purpose processor, a conventional processor, a digital signal processor (DSP), a plurality of microprocessors, one or more microprocessors in

association with a DSP core, a controller, a microcontroller, Application Specific Integrated Circuits (ASICs), Field Programmable Gate Arrays (FPGAs) circuits, any other type of integrated circuit (IC), and/or a state machine.

[0043] A processor in association with software may be used to implement a radio frequency transceiver for use in a wireless transmit receive unit (WTRU), user equipment (UE), terminal, base station, radio network controller (RNC), or any host computer. The WTRU may be used in conjunction with modules, implemented in hardware and/or software, such as a camera, a video camera module, a videophone, a speakerphone, a vibration device, a speaker, a microphone, a television transceiver, a hands free headset, a keyboard, a Bluetooth® module, a frequency modulated (FM) radio unit, a liquid crystal display (LCD) display unit, an organic light-emitting diode (OLED) display unit, a digital music player, a media player, a video game player module, an Internet browser, and/or any wireless local area network (WLAN) or Ultra Wide Band (UWB) module.

[0044] Embodiments:

1. A method of high speed downlink packet access (HSDPA) link adaptation.
2. The method of embodiment 1, further comprising receiving a channel quality measurement metric over a Measured Results on random access channel (RACH) information element (IE).
3. A method as in any preceding embodiment, further comprising adapting a link based upon the received channel quality metric.
4. A method as in any preceding embodiment, further comprising filtering the channel quality measurement metric.
5. A method as in any preceding embodiment wherein the link adaptation is based on the filtered channel quality measurement metric.
6. A method as in any preceding embodiment, further comprising performing a channel quality metric measurement.

7. A method as in any preceding embodiment, further comprising transmitting a channel quality metric measurement over a Measured Results on random access channel (RACH) information element (IE).

8. A method as in any preceding embodiment wherein a channel quality metric measurement is based on a universal terrestrial radio access (UTRA) carrier received signal strength indication (RSSI) measured in a Cell_FACH state.

9. A method as in any preceding embodiment wherein a channel quality metric measurement is based on the Channel Quality Indication (CQI) calculated by a physical layer of a wireless transmit/receive unit (WTRU).

10. A method as in any preceding embodiment wherein the channel quality metric measurement is based on a carrier to interference ratio (CPICH C/I) calculated from measurements taken in any one of the following states: Cell_FACH, Cell_PCH, URA_PCH, and Idle.

11. A method as in any preceding embodiment wherein a channel quality metric measurement is based on any one of the following factors: received signal code power, total interference, and capability of a wireless transmit/receive unit (WTRU).

12. A method as in any preceding embodiment wherein transmitting a channel quality metric measurement over the Measured Results on RACH IE includes transmitting a plurality of channel quality metrics.

13. A method as in any preceding embodiment, further comprising observing channel quality measurements.

14. A method as in any preceding embodiment, further comprising synchronizing the channel quality measurements with forward access channel (FACH) measurement occasions.

15. A method as in any preceding embodiment, further comprising synchronizing the channel quality measurements with a WTRU discontinuous reception (DRX) cycle.

16. A method as in any preceding embodiment wherein synchronization includes matching the WTRU measurement period to a multiple of the WTRU DRX cycle.

17. A method as in any preceding embodiment, further comprising measuring a reported quantity at a next opportunity provided by a WTRU DRX cycle following the expiration of a measurement period.

18. A Node B configured to perform a method as in any preceding embodiment.

19. The Node B of embodiment 18, further comprising a receiver.

20. A Node B as in any of embodiments 18-19, further comprising a transmitter.

21. A Node B as in any of embodiments 18-20, further comprising a processor in communication with the receiver and the transmitter.

22. A Node B as in any of embodiments 18-21 wherein a processor is configured to receive a channel quality metric over a Measured Results on random access channel (RACH) information element (IE).

23. A Node B as in any of embodiments 18-22 wherein a processor is configured to adapt a link based upon the received channel quality metric.

24. A Node B as in any of embodiments 18-23 wherein a processor is further configured to filter the channel quality metric.

25. A Node B as in any of embodiments 18-24 wherein link adaptation is based on a filtered channel quality metric.

26. A WTRU configured to perform a method as in any of embodiments 1-17.

27. The WTRU of embodiment 26, further comprising a receiver.

28. A WTRU as in any of embodiments 26-27, further comprising a transmitter.

29. A WTRU as in any of embodiments 26-28, further comprising a processor in communication with the receiver and the transmitter.

30. A WTRU as in any of embodiments 26-29 wherein a processor is configured to perform a channel quality metric measurement.

31. A WTRU as in any of embodiments 26-30 wherein a processor is configured to transmit a channel quality metric measurement over a Measured Results on random access channel (RACH) information element (IE).

32. A WTRU as in any of embodiments 26-31 wherein a channel quality metric measurement is based on a universal terrestrial radio access (UTRA) carrier received signal strength indication (RSSI) measured in a Cell_FACH state.

33. A WTRU as in any of embodiments 26-32 wherein a channel metric measurement is based on any combination of the following factors: received signal code power, total interference, and/or capability of the WTRU.

34. A WTRU as in any of embodiments 26-33 wherein a channel quality metric measurement is based on a carrier to interference ratio (CPICH C/I) calculated from measurements taken in any one of the following states: Cell_FACH, Cell_PCH, URA_PCH, and Idle.

35. A WTRU as in any of embodiments 26-34 wherein a processor is configured to observe channel quality measurements.

36. A WTRU as in any of embodiments 26-35 wherein a processor is configured to synchronize channel quality measurements with forward access channel (FACH) measurement occasions.

37. A WTRU as in any of embodiments 26-36 wherein a processor is configured to synchronize channel quality measurements with a WTRU discontinuous reception (DRX) cycle.

38. A WTRU as in any of embodiments 26-37 wherein synchronization includes matching the WTRU measurement period to a multiple of the WTRU DRX cycle.

39. A WTRU as in any of embodiments 26-38 wherein a processor is further configured to measure a reported quantity at a next opportunity provided by a WTRU DRX cycle following the expiration of a measurement period.

40. A method as in any of embodiments 1-17, further comprising making Inter-frequency and/or Inter-RAT measurements in DRX periods rather than the forward access channel (FACH) measurement occasions.

41. A method as in any of embodiments 1-17 wherein a Measured Results on RACH IE is included in the URA UPDATE Radio Resource Control (RRC) message and/or other uplink RRC messages.

* * *

THE CLAIMS DEFINING THE INVENTION ARE AS FOLLOWS:

1. A method of high speed downlink packet access (HSDPA) link adaptation, including:
 - performing a channel quality metric measurement, in a state that a wireless transmit/receive unit (WTRU) does not have a dedicated link, in synchronization with a WTRU discontinuous reception (DRX) cycle; and
 - transmitting the channel quality metric measurement over a Measured Results on random access channel (RACH) information element (IE).
2. The method of claim 1 wherein the channel quality metric measurement is based on a universal terrestrial radio access (UTRA) carrier received signal strength indication (RSSI) measured in a Cell_FACH state.
3. The method of claim 1 wherein the channel quality metric measurement is based on the Channel Quality Indication (CQI) calculated by a physical layer of a wireless transmit/receive unit (WTRU).
4. The method of claim 1 wherein the channel quality metric measurement is based on a carrier to interference ratio (CPICH C/I) calculated from measurements taken in any one of the following states: Cell_FACH, Cell_PCH, URA_PCH, and Idle.
5. The method of claim 1 wherein the channel quality metric measurement is based on any one of the following factors: received signal code power, total interference, and capability of a wireless transmit/receive unit (WTRU).
6. The method of claim 1 wherein transmitting the channel quality metric measurement over the Measured Results on RACH IE includes transmitting a plurality of channel quality metrics.
7. The method of claim 1 wherein the Measured Results on RACH IE is included in any one of the following messages: the URA UPDATE Radio Resource Control (RRC) message, and other uplink RRC message.

8. A wireless transmit/receive unit (WTRU), including:
a receiver;
a transmitter; and

a processor in communication with the receiver and the transmitter, the
5 processor configured to performing a channel quality metric measurement, in a
state that the WTRU does not have a dedicated link, in synchronization with a
WTRU discontinuous reception (DRX) cycle, and transmit the channel quality
metric measurement over a Measured Results on random access channel
(RACH) information element (IE).

10 9. The WTRU of claim 8 wherein the channel quality metric measurement is
based on a universal terrestrial radio access (UTRA) carrier received signal
strength indication (RSSI) measured in a Cell_FACH state.

15 10. The WTRU of claim 8 wherein the channel quality metric measurement is
based on the Channel Quality Indication (CQI) calculated by a physical layer of
the WTRU.

11. The WTRU of claim 8 wherein the channel quality metric measurement is
based on a carrier to interference ratio (CPICH C/I) calculated from
measurements taken in any one of the following states: Cell_FACH, Cell_PCH,
URA_PCH, and Idle.

20 12. The WTRU of claim 8 wherein the channel quality metric measurement is
based on any one of the following factors: received signal code power, total
interference, and capability of the WTRU.

13. The WTRU of claim 8 wherein the processor is configured to transmit a
plurality of channel quality metrics over the Measured Results on RACH IE.

25 14. The WTRU of claim 8 wherein the Measured Results on RACH IE is
included in any one of the following messages: the URA UPDATE Radio
Resource Control (RRC) message, and other uplink RRC message.

15. The method of claim 1 and substantially as hereinbefore described.
16. The WTRU of claim 8 and substantially as hereinbefore described.

INTERDIGITAL TECHNOLOGY CORPORATION

WATERMARK PATENT & TRADE MARK ATTORNEYS

P32370AU00

100

1/3

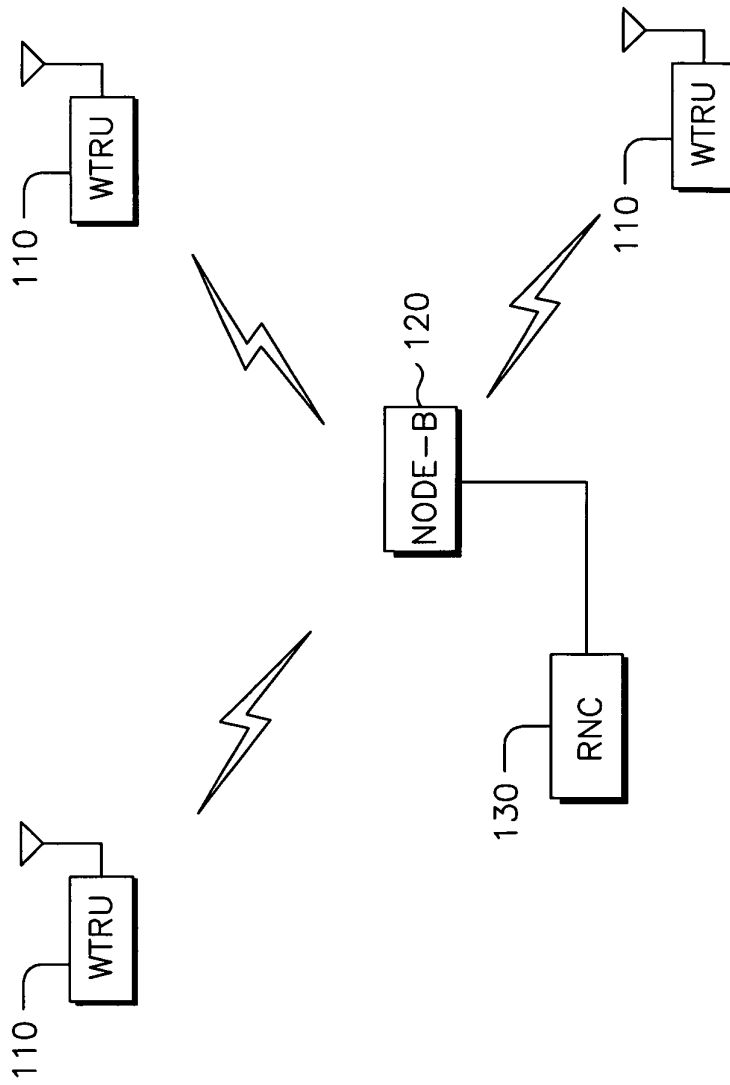

FIG.1

200

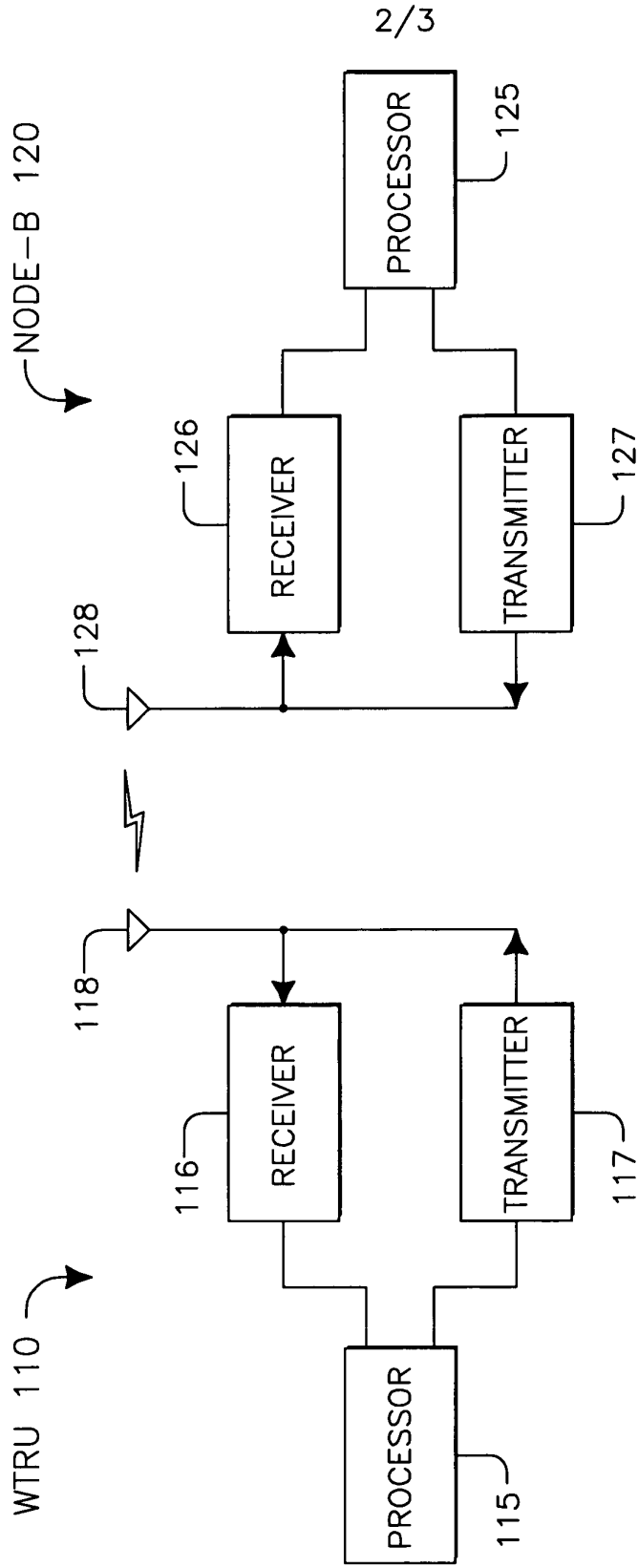
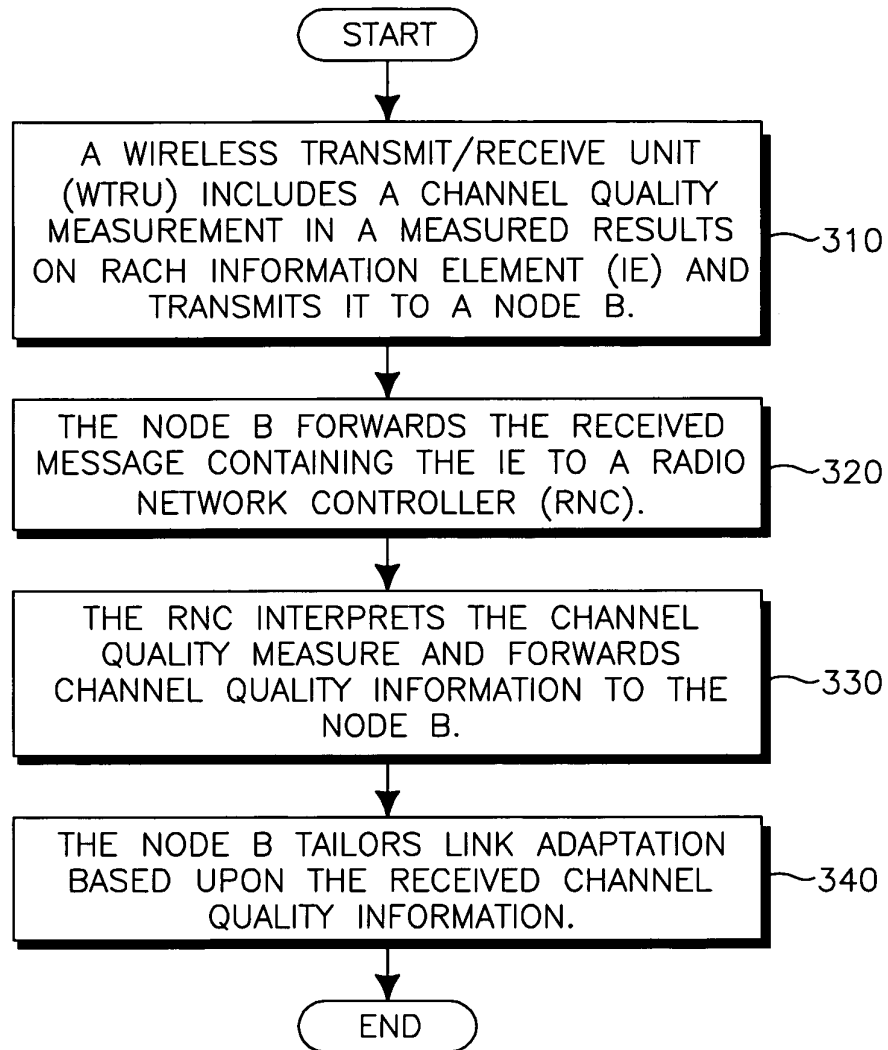

FIG.2

3/3

300**FIG.3**