



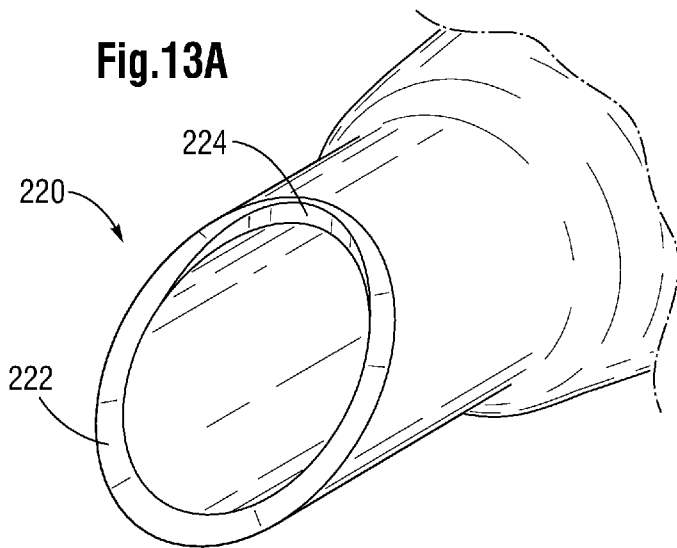
- (51) International Patent Classification:  
*A61F 2/16* (2006.01)
- (21) International Application Number:  
PCT/US2014/019987
- (22) International Filing Date:  
3 March 2014 (03.03.2014)
- (25) Filing Language: English
- (26) Publication Language: English
- (30) Priority Data:  
61/773,496 6 March 2013 (06.03.2013) US
- (71) Applicant: **ABBOTT MEDICAL OPTICS INC.**  
[US/US]; 1700 E. St. Andrew Place, Santa Ana, CA 92705 (US).
- (72) Inventors; and
- (71) Applicants : **SAFABASH, Jason, H.** [US/US]; 27310 Cloverly, Mission Viejo, CA 92692 (US). **GAYLORD, David, W.** [US/US]; 160 E. 21st. Street-Unit F, Santa Ana, CA 92627 (US). **SPRINGER, Kevin, R.** [US/US]; 18642 Auburn Ave., Santa Ana, CA 92705 (US).
- (74) Agent: **KIM, Roy**; c/o Abbott Medical Optics Inc., 1700 E. St. Andrew Place, Santa Ana, CA 92705 (US).

(81) Designated States (unless otherwise indicated, for every kind of national protection available): AE, AG, AL, AM, AO, AT, AU, AZ, BA, BB, BG, BH, BN, BR, BW, BY, BZ, CA, CH, CL, CN, CO, CR, CU, CZ, DE, DK, DM, DO, DZ, EC, EE, EG, ES, FI, GB, GD, GE, GH, GM, GT, HN, HR, HU, ID, IL, IN, IR, IS, JP, KE, KG, KN, KP, KR, KZ, LA, LC, LK, LR, LS, LT, LU, LY, MA, MD, ME, MG, MK, MN, MW, MX, MY, MZ, NA, NG, NI, NO, NZ, OM, PA, PE, PG, PH, PL, PT, QA, RO, RS, RU, RW, SA, SC, SD, SE, SG, SK, SL, SM, ST, SV, SY, TH, TJ, TM, TN, TR, TT, TZ, UA, UG, US, UZ, VC, VN, ZA, ZM, ZW.

(84) Designated States (unless otherwise indicated, for every kind of regional protection available): ARIPO (BW, GH, GM, KE, LR, LS, MW, MZ, NA, RW, SD, SL, SZ, TZ, UG, ZM, ZW), Eurasian (AM, AZ, BY, KG, KZ, RU, TJ, TM), European (AL, AT, BE, BG, CH, CY, CZ, DE, DK, EE, ES, FI, FR, GB, GR, HR, HU, IE, IS, IT, LT, LU, LV, MC, MK, MT, NL, NO, PL, PT, RO, RS, SE, SI, SK, SM, TR), OAPI (BF, BJ, CF, CG, CI, CM, GA, GN, GQ, GW, KM, ML, MR, NE, SN, TD, TG).

Published: — with international search report (Art. 21(3))

(54) Title: ATRAUMATIC IOL INSERTION CARTRIDGE OPENING



(57) Abstract: This intraocular lens (IOL) injector cartridge has a proximal opening in a main body for receiving an IOL. The main body has a lumen that extends longitudinally to a distal end having an opening smaller than the IOL. Passage through the lumen compresses or rolls the IOL so that when the distal end is inserted through a small incision in the eye the IOL can be expelled into the capsular bag. The distal end of the cartridge is beveled with a leading tip in front of a trailing heel. The characteristics of the beveled end are such that damage to the IOL is reduced. The bevel may be straight or curved and includes a distal face defined by the thickness of the distal end between the lumen and an exterior surface. The distal face may be flush with the bevel or chamfered. An inner corner angle between the distal face and the lumen is  $\geq 60^\circ$  to reduce the chance of scratching the IOL as it passes out of the distal opening.

WO 2014/137925 A1

## ATRAUMATIC IOL INSERTION CARTRIDGE OPENING

5

### Cross References to Related Applications

[0001] This application claims priority to U.S. provisional application No. 61/773,496 filed on March 6, 2013, the entire contents of which are incorporated herein by reference. Full Paris Convention priority is hereby expressly reserved.

### Field of the Invention

[0002] The present invention relates to devices for delivering an intraocular lens (IOL) into an eye and, more particularly, to an atraumatic IOL injector cartridge tip.

### Background of the Invention

[0003] It is estimated that at least about 42% of Americans between the ages of 52 and 64 and 73% of Americans between the ages of 65 and 74 get cataracts. A cataract is a clouding of the eye's lens that impairs a person's vision and, if left untreated, causes blindness. As a result, each year approximately 1.4 million people in the United States alone undergo cataract surgery, whereby the clouded lens is removed and replaced with an intraocular lens (IOL) implant.

[0004] A typical IOL includes an optic or lens body for focusing light toward the retina of the eye. In addition, the IOL also includes one or more fixation members or haptics extending outward from the optic for securing and centering the IOL in the desired position within the chamber of the eye. The IOL is implanted directly into the eye through a small incision in a way that reduces trauma and expedites post-surgery healing. To fit through this small incision, modern IOLs are designed to be deformed, e.g., rolled, folded or the like, to a relatively small profile and then allowed to return to their original shape within the eye.

[0005] A useful technique for inserting an IOL into the eye includes use of an IOL injector or cartridge. Injectors for delivering IOLs into the eye typically employ a handpiece and

a cartridge having a hollow insertion tube or cannula through which the folded IOL is passed using a pushrod. The cartridges are made of disposable materials, such as plastics, and remain in a sterile package until ready for coupling with the handpiece. Some injectors do without the cartridge, and may be reusable.

5           [0006] Conventional IOL cartridges include a load chamber connected to an injection tube. In many popular versions, such as in U.S. Patent U.S. Patent Nos. 4,681,102 to Bartell or 5,702,402 to Brady, the load chamber is formed by two hinged halves which receive the IOL, and which close to fold the IOL. A non-folding cartridge is seen in U.S. Patent No. 5,474,562 to Orchowski in which forceps are used to insert the IOL into a proximal or rear opening of the  
10 cartridge. The injection tube includes a small diameter distal end that is insertable into the incision within the eye. After mating the cartridge with the handpiece (if a separate cartridge is used), the pushrod urges the IOL through the load chamber and through the injection tube into the eye. The distal end of the cartridge is beveled into a sharp point that enables insertion through the corneal incision and facilitates expulsion and manipulation of the IOL into the  
15 capsular bag. However, sometimes the IOL or the cartridge tip is damaged during the process of forcing the IOL through the cartridge tube.

[0007] In view of the above, there is a need for a cartridge that will not damage the IOL and is more robust than earlier designs.

20

#### Summary of the Invention

[0008] The present application provides an intraocular lens (IOL) injector cartridge having an atraumatic tip. The cartridge includes a main body having a proximal opening for receiving an IOL and a lumen that extends longitudinally to a distal end having a distal opening smaller than the IOL. Passage through the lumen compresses or rolls the IOL so that when the  
25 distal end is inserted through a small incision in the eye the IOL can be expelled into the capsular bag. The distal end of the cartridge is beveled with a leading tip in front of a trailing heel. The characteristics of the beveled end are such that damage to the IOL is reduced. The bevel may be straight or curved and includes a distal face defined by the thickness of the distal end between the lumen and an exterior surface. The distal face may be flush with the bevel or

chamfered. An inner corner angle between the distal face and the lumen is  $\geq 60^\circ$  to reduce the chance of scratching the IOL as it passes out of the distal opening.

[0009] The exemplary cartridges disclosed herein for receiving and delivering an intraocular lens to the inner eye comprises a main body extending longitudinally from a proximal opening for receiving the intraocular lens to a distal end. A lumen extends from the proximal opening to the distal end which defines a distal opening that is smaller than the intraocular lens. The distal end is beveled as seen in side view with a leading tip below and opposite a trailing heel, and further defines a distal face between an exterior surface and the lumen.

[0010] In one embodiment, the distal face including at least one portion that is not flush with the beveled distal end as seen in side view. The beveled distal end may be a straight bevel or a curved bevel. The portion of the distal face that is not flush with the beveled distal end may be a chamfer formed in a cutout region. Alternatively, the distal face is not flush with the beveled distal end around its entire periphery. For instance, the entire distal face may be chamfered or rounded.

[0011] In another embodiment, the distal face forms an inner corner with a wall of the lumen at the trailing heel having an angle  $\phi \geq 60^\circ$ , and preferably  $\phi \geq 90^\circ$ . In a further embodiment, the distal face includes at least one portion that is rounded. If the distal end has a curved bevel as seen in side view, the bevel angle adjacent the leading tip is desirably greater than the bevel angle adjacent the trailing heel. In one embodiment, the bevel is a planar bevel as seen in side view, and the angle  $\beta$  of the planar bevel is between about  $20\text{-}30^\circ$  such that a distal face forms an inner corner with a wall of the lumen at the trailing heel having an angle  $\phi$  between about  $60\text{-}70^\circ$ .

#### Brief Description of the Drawings

[0012] Features and advantages of the present invention will become appreciated as the same become better understood with reference to the specification, claims, and appended drawings wherein:

[0013] Figure 1 is a perspective view of a prior art intraocular lens (IOL) inserter cartridge showing loading of an exemplary IOL from the rear end thereof;

[0014] Figure 2A is a top plan view of the cartridge of Figure 1, while Figure 2B is a longitudinal sectional view through the cartridge illustrating progressive advancement of an IOL therethrough to a beveled distal end, and Figure 2C is an enlargement of the distal end in section;

5 [0015] Figure 3 is a side elevation view of the distal end of an alternative IOL cartridge of the present application having a shallower bevel angle;

[0016] Figures 4A-4C are perspective, elevational, and sectional views of the distal end of a further alternative IOL cartridge disclosed herein, while Figures 4D and 4E are enlargements of areas in Figure 4C;

10 [0017] Figure 5 is a perspective view partly in phantom of an alternative IOL cartridge of the present application having a variable chamfered edge at the beveled tip, while Figure 5A is an enlarged view of the distal end;

[0018] Figures 6A-6D are different views of the variable chamfered edge bevel tip of the cartridge of Figure 5, while Figures 6E and 6F are enlargements of areas in Figure 6D;

15 [0019] Figure 7 is a perspective view partly in phantom of another IOL cartridge of the present application having a variable chamfered edge at the beveled tip, while Figure 7A is an enlarged view of the distal end;

[0020] Figures 8A-8D are different views of the variable chamfered edge bevel tip of the cartridge of Figure 7, while Figures 8E and 8F are enlargements of areas in Figure 8D;

20 [0021] Figure 9 is a perspective view partly in phantom of another IOL cartridge of the present application having a more rounded edge at the beveled tip, while Figure 9A is an enlarged view of the distal end;

[0022] Figures 10A-10D are different views of the rounded edge bevel tip of the IOL cartridge of Figure 9, while Figures 10E and 10F are enlargements of areas in Figure 10D;

25 [0023] Figures 11A and 11B are elevation and sectional views through a still further IOL cartridge tip having a curved tip with a step;

[0024] Figures 12A and 12B are perspective and elevation views through a still further IOL cartridge tip having a curved tip with a less pronounced step than in Figures 11A-11B; and

[0025] Figures 13A and 13B are perspective and elevation views through another IOL cartridge beveled tip with a partial cut out at the bevel heel.

30

### Detailed Description of the Preferred Embodiments

[0026] Figures 1-2C illustrate an IOL cartridge 20 of the prior art which includes a main body 22 extending longitudinally from a proximal opening 24 to a distal end 26. A pair of webs project transversely outward from opposite sides of the main body 22 and terminate in a generally vertically-oriented finger grip 30a, 30b. The main body 22 of the cartridge 20 defines a gradually narrowing lumen or hollow interior 32 extending longitudinally from the proximal opening 24 to a distal opening 34 (Figure 2B) at the distal end 26.

[0027] Figure 1 illustrates an IOL held by tongs or forceps 50. This type of IOL includes a central disc-shaped optic 52, a leading haptic 54, and a trailing haptic 56. Typically, the optic 52 has opposed convex faces, although the present invention is not limited to cartridges for any particular type of IOL. The haptics 54, 56 are shown as thin arcuate members extending outward from opposite edges of the optic 52, and generally in the plane of the optic. The haptics 54, 56 curve in the same direction, in this case a counter-clockwise direction looking down on the IOL.

[0028] Figure 2B shows the gradually narrowing lumen 32 from the proximal to the distal end of the cartridge 20, and the general shape of the IOL as it progresses through the main body 22. In particular, the cartridge 20, as with other such cartridges, provides a gradually narrowing lumen 32 that folds or otherwise compresses the IOL into a small profile so that it may be expelled through the distal opening 34 at the distal end 26 and through an incision into the eye. Intraocular lenses are inserted into the empty capsular bag left after removing the natural lens from the eye, typically due to opacification from conditions such as glaucoma. Folding the IOL through the cartridge enables a smaller incision to be used, which helps reduce trauma during the operation and recovery. However, folding and/or compressing the IOL generates significant compressive stresses in the IOL, which is restrained by the surrounding cartridge tube. The outward forces from the IOL against the tube lumen 32 and opposite inward reaction forces from the lumen on the IOL are alleviated at the moment the IOL emerges from the distal opening, and sometimes the sharp edges of the distal end cause damage to the IOL.

[0029] The shape of the distal end 26 facilitates introduction of the IOL into the eye and into the capsular bag. More particularly, the distal end 26 defines the termination of the generally tubular main body 22 and features a planar bevel angle  $\beta$  that results in a pointed

leading tip 36 diametrically opposed to a trailing heel 38, such as seen in Figure 2C. Due to the planar bevel, the side portions of the distal end 26 extend in half-ovals between the leading tip 36 and a trailing heel 38. The pointed leading tip 36 helps the surgeon open up the incision and extend the distal end 26 into the eye and into the capsular bag, while the relief provided by the  
5 bevel angle  $\beta$  allows the IOL to emerge more gradually from the tip than if the tube was cut off straight, or perpendicular to the central axis. Moreover, the end 26 may be rotated about its axis to allow the surgeon to reposition the heel 38 and thus “aim” the cartridge tip so that the IOL is expelled properly into the capsular bag. The planar beveled end 26 as shown typically has a  
10 bevel angle  $\beta$  of about  $55^\circ$  which is conventional in the art and provides adequate level of control for the surgeon. It should be noted that the bevel angles discussed herein refer to the angle (if there is a single angle) taken from a vertical plane (perpendicular to the central axis of the tubular main body 22) to the distal end 26, indicated in Figure 2C. Consequently, a  $0^\circ$  bevel angle is one which is perpendicular to the central axis, or completely blunt and not beveled at all, and thus does not exist as it does not work. Conversely, the distal end becomes increasingly  
15 sharp at higher bevel angles, and angles above  $45^\circ$  are impractically long and do not exist either. Known bevels are between  $40\text{-}55^\circ$ .

[0030] Certain problems in the use of cartridges with planar bevels have been noted by the applicants. It should be understood that a “planar bevel” refers to a distal end 26 that defines a forward-looking distal face that lies exclusively in the plane of the bevel angle, or is flush with  
20 the bevel. The distal face of the distal end 26 is that surface formed by the thickness of the distal end that extends between the outer 40 and inner 42 tubular walls of the cartridge 20 (Figure 2C). The entire distal face of the distal end 26 across the wall thickness of the cartridge 20 thus lies flush in a common plane along the bevel angle. This can also be termed a flush distal face because it lies flush within the contour of the distal end as seen from the side (Figure 2C).  
25 Consequently, the trailing heel 38 of the distal end 26 forms the same sharp angle at the inside wall 42. As a result, as the IOL emerges from within the tubular lumen 32, the sharp inner corner angle of the heel 38 sometimes causes cuts or scratches on the expanding IOL, which are sometimes referred to as chatter marks.

[0031] Moreover, because of the sharp angle at the heel 38, the outward pressure  
30 imparted by the passing IOL sometimes creates splits in the cartridge material. That is, the sharp

angle at the heel 38 presents an area of concentrated stress in the material which can sometimes split, potentially leading to loss of control of the delicate placement process. Furthermore, advances in the field of IOL implantation are driving the diameter of the cartridge distal tips ever smaller, which further reduces the strength of the distal tip. At some point, the strength limit of the distal tip is reached which limits its minimum size. Currently, the smallest distal tips having a planar bevel are 1.6 mm in diameter, with a wall thickness of .0016 mm.

[0032] The present application provides a number of solutions to help eliminate damage to either the IOL or the cartridge end 26. One solution shown in Figure 3 involves a cartridge 60 having a distal end 62 with a planar bevel having a much shallower bevel angle  $\beta$ , such as approximately 30°, or less. More particularly, the bevel angle  $\beta$  is preferably between about 20-30°. By virtue of the shallower bevel angle, the distal face at the heel 66 of the distal end 62 also forms a shallower inner corner angle at the inside wall, thus reducing the potentially damaging sharp edge and also the stress concentration at that point. More specifically, for bevel angles  $\beta$  between 20-30°, the distal face forms an inner corner with a wall of the lumen at the trailing heel 66 that is between 60-70

[0033] Another alternative IOL cartridge 70 is seen in Figures 4A-4C, and includes a distal end 72 that forms a straight bevel angle  $\beta$  of about 65°, much like those in the prior art. A distal face 74 formed by the thickness of the distal end 72 between an outer wall 76 and an inner wall 78 defines the forward-looking end of the cartridge. An outer edge 80 of the distal face 74 lies in and defines the plane of the bevel angle  $\beta$ , preferably about 40-45°. Since the bevel as seen from the side as in Figure 4B is straight, this configuration can be denoted a straight bevel. A planar bevel as described above is a subset of straight bevels. However, instead of being a planar bevel, the distal face 74 is angled or chamfered such that not all of it lies in the plane of the bevel angle  $\beta$ . In particular, an inner edge 82 of the distal face 74 does not lie in the plane of the bevel angle  $\beta$ . Another way to describe the distal face 74 is that it does not lie flush within the bevel plane.

[0034] With reference to Figures 4A and 4C, the distal end 72 has a variable chamfer around its circumference. As seen best in the enlargement of Figures 4D and 4E, the angle of the distal face 74 (face angle) changes from an angle  $\theta$  that is greater than the bevel angle (i.e., sharper) at a leading tip 84 (See Figure 4D) to one that is more blunt than the bevel angle at a

trailing heel 86. As before, the leading tip 84 is diametrically opposed around the distal end 72 from the trailing heel 86. The face angle around the distal end 72 is that angle the distal face 74 makes with a plane perpendicular to the tubular axis as seen in any longitudinal section through the distal end (such as seen in Figures 4C-4E with a vertical longitudinal section). In the  
5 illustrated embodiment, the face angle at the heel 86 is  $0^\circ$ , as seen in Figure 4E. Consequently, the inner edge 82 of the distal face 74 at the trailing heel 86 forms an inner corner angle  $\phi$  of about  $90^\circ$  at the intersection with the cartridge inner wall 78. This removes the sharp edge at the heel 86 which reduces the chance of damaging the IOL as it expulses from the distal end 72. Another way to state this solution is that the inner corner angle  $\phi$  at the trailing heel 86 is  
10 decoupled from the bevel angle  $\beta$ , which is not the case with a planar bevel.

[0035] Various side and sectional views seen in the present application are depicted with the leading tip 84 directly below the trailing heel 86, or vice versa, which simplifies depiction of the particular beveled distal end because of the traditional symmetry about a central plane that extends through the leading tip and trailing heel. However, it should be understood that  
15 asymmetric distal ends are not excluded unless explicitly stated herein for particular embodiments.

[0036] Now with reference to Figures 5 and 5A, a still further alternative IOL cartridge 90 is shown. The cartridge 90 is configured differently than that described above, though it is still adapted to receive an IOL and then mate with an inserter (not shown) for injection into an  
20 eye. Although the majority of the cartridge 90 is not particularly relevant to the disclosure of the present invention, and thus is shown in phantom, it typically includes a proximal body 92 having a proximal opening 94 in the form of a channel for receiving an IOL. A tubular nose 96 aligned with the opening 94 extends distally from the body 92 and terminates at a distal end 100. As with the earlier embodiment, the distal end 100 defines an opening that is smaller than the IOL  
25 such that as the IOL progresses distally from the proximal opening 94 is folded or otherwise compressed into a rolled configuration.

[0037] The distal end 100 is shown in greater detail in Figures 6A-6F, and defines a straight bevel angle  $\beta$  as seen in Figure 6D, preferably about  $40-45^\circ$ . Once again, an outer edge 102 of a distal face 104 lies in and defines the bevel plane. The distal face 104 extends between  
30 an outer cartridge wall 106 and an inner cartridge wall 108 that defines the tube lumen. Again in

contrast to a planar bevel, the distal face 104 has a chamfer angle that does not lie flush in the bevel plane.

[0038] As best seen in Figures 5A and 6D, an inner edge 110 of the distal face 104 is recessed into the lumen. At a leading tip 112 of the bevel, as seen in Figure 6E, the distal face 104 makes a chamfer angle  $\theta$  that is larger than the bevel angle. At a trailing heel 114, diametrically opposed to the leading tip 112 as seen in Figure 6F, the distal face 104 makes a chamfer angle  $\alpha$  that is also larger than the bevel angle, and in the opposite direction. It should be noted that a chamfer at the trailing heel 114 which forms an angle opposite to the bevel angle and is greater than  $0^\circ$  (such as in Figure 4E) results in an obtuse inner corner angle  $\phi$ . The angle  $\theta$  may be equal to the angle  $\alpha$  or one may be larger than the other. In a preferred embodiment, the distal face chamfer angle  $\theta$  at the leading tip 112 is equal to the distal face chamfer angle  $\alpha$  at the trailing heel 114, and they both are between about  $70$ - $80^\circ$ . Although the trailing chamfer angle  $\alpha$  may be as small as  $0^\circ$ , such as in the embodiment of Figures 4A-4E, it is desirably greater than  $30^\circ$  to result in an obtuse inner corner angle. Both the leading tip 112 and trailing heel 114 therefore define sharp points at their outer edges 102, but relatively shallow (obtuse) inner corner angles at their inner edges 110. These shallow corner angles serve two purposes: first, there is little chance of the inner edges 110 causing damage to the passing IOL, and second, the material at the inner edges 110 experiences no stress concentration which might lead to tearing.

[0039] A still further alternative distal end 120 for an IOL cartridge 90 is shown in Figures 7-8. The IOL cartridge 90 may be similar to that shown in Figure 5, or may be another configuration such as that shown in Figure 1. Once again, the majority of the cartridge 90 is not particularly relevant to the disclosure of the present invention, and thus is shown in phantom.

[0040] The distal end 120 is shown in greater detail in Figures 7A and 8A-8F, and defines a straight bevel angle  $\beta$  as seen in Figure 8D, preferably about  $40$ - $45^\circ$ . Once again, an outer edge 122 of a distal face 124 lies in and defines the bevel plane. The distal face 124 extends between an outer cartridge wall 126 and an inner cartridge wall 128 that defines the tube lumen. Again, in contrast to a planar bevel, the distal face 124 has a chamfer angle that does not lie flush in the bevel plane. The distal end 120 is similar to the distal end 100 of Figures 5-6, though one difference is that the extension of the tubular nose 96 of the cartridge 90 becomes

gradually more elliptical, or more like a rounded rectangle. This configuration may accommodate the IOLs somewhat better as the optic portion assumes a more flattened as opposed to rolled tubular shape.

[0041] As best seen in Figures 7A and 8D, an inner edge 130 of the distal face 124 is recessed into the lumen. At a leading tip 132 of the bevel, as seen in Figure 8E, the distal face 124 makes a chamfer angle  $\theta$  that is larger than the bevel angle. At a trailing heel 134, as seen in Figure 8F, the distal face 124 makes a chamfer angle  $\alpha$  that is opposite the bevel angle. The angle  $\theta$  may be equal to the angle  $\alpha$  or one may be larger than the other. In a preferred embodiment, the distal face chamfer angle  $\theta$  at the leading tip 132 is greater than the distal face chamfer angle  $\alpha$  at the trailing heel 134. For instance, the leading chamfer angle  $\theta$  is between about 70-80°, while the trailing chamfer angle  $\alpha$  is between about 60-70°. Once again, it should be noted that the trailing chamfer angle  $\alpha$  may be as small as 0°, such as in the embodiment of Figures 4A-4E, though it is desirably greater than 30° to result in an obtuse inner corner angle. Both the leading tip 132 and trailing heel 134 therefore define sharp points at their outer edges 122, but relatively shallow (obtuse) inner corner angles at their inner edges 130. These shallow corner angles reduce the chance of the inner edges 130 causing damage to the passing IOL, and reduce the stress concentration in the distal end 120 which might lead to tearing.

[0042] Figure 8F also shows a somewhat different trailing heel 134 than in earlier embodiments. The distal face 124 at that point does not intersect the outer cartridge wall 126, but instead terminates at its outer edge 122 a short way down the straight bevel. Another way to state this is that the distal face 124 at the trailing heel 134 does not pass through the intersection of the bevel with the outer cartridge wall 126. This results in a short length of added material at the sharp point of the outer cartridge wall 126 which helps strengthen the wall and avoids tearing during expulsion of the compressed IOL.

[0043] A still further alternative distal end 140 for an IOL cartridge 90 is shown in Figures 9-10. Once again, the IOL cartridge 90 may be similar to that shown in Figure 5, or may be another configuration such as that shown in Figure 1. The distal end 140 is shown in greater detail in Figures 9A and 10C-10F, and once again defines a straight bevel angle  $\beta$  as seen in Figure 10D, preferably about 40-45°. An outer edge 142 of a distal face lies in and defines the bevel plane. As before, the distal face extends between an outer cartridge wall 144 and an inner

cartridge wall 146 that defines the tube lumen. In contrast to a planar bevel, the distal face does not lie flush in the bevel plane, but in this configuration there is no single chamfer but a more rounded face from the trailing heel 148 to the leading tip 150 and in between.

5 [0044] As best seen in Figure 10E, at a leading tip 150 of the bevel the distal face extends between an outer edge 152 and an inner edge 154 and forms a rounded face 156. At the trailing heel 148, as seen in Figure 10F, the distal face forms a rounded face 158. These rounded faces 156, 158 may have similar curvatures, though due to their different geometries the rounded face 158 at the trailing heel 148 extends around a greater arc than the face 156 at the leading tip 150. The result is a smooth surface around the distal end 140 of the cartridge 90, which  
10 eliminates any sharp edges and corresponding danger of scratching the IOL. It should be noted that a rounded distal face is not flush with the particular bevel, much like the earlier-described chamfers.

[0045] Now with reference to Figures 11A-11B, a slightly different cartridge distal end 170 is shown. As before, the distal end 170 is pointed with a leading tip 172 and a trailing heel 174. However, instead of the straight bevel, the distal end 170 has a curved bevel, with a relatively shallow curvature 176 adjacent the leading tip 172 gradually increasing to a step 178 adjacent the trailing heel 174. In the illustrated embodiment, the angle of the curved bevel at the trailing heel 174 is about  $0^\circ$ . Desirably, the bevel angle adjacent the leading tip 172 is greater than the bevel angle adjacent the trailing heel 174. This “curved bevel” is not strictly a bevel,  
20 but the terminology will be used to indicate its proximity to a straight bevel. In other words, as used herein, a beveled end refers to both straight and curved bevels, wherein both include a leading tip opposed to a trailing heel. Also as mentioned above, a preferred configuration provides symmetry about a central plane through a diametrically opposed leading tip 172 and trailing heel 174, though a symmetric configurations are contemplated.

25 [0046] Furthermore, the distal face is flush with the curved bevel, meaning that the entire distal face lies in the curvature of the distal end 170 as seen from the side in Figure 11A. Consequently, as seen in Figure 11B, the distal face has a  $90^\circ$  inner corner angle 180 at the trailing heel 174, much like the embodiment of Figures 4A-4C. Once more, this reduces the potential for damaging IOL as it passes out of the lumen of the cartridge end 170. Of course, the

distal face need not lie flush within the curvature of the distal end 170, and may be chamfered as described in several embodiments above.

[0047] Figures 12A-12B illustrate a still further cartridge distal end 190 having a curved bevel. In particular, the curved bevel extends between a leading tip 192 and a trailing heel 194. As with the embodiment of Figures 11A-11B, the distal face lies flush with the curvature of the curved bevel. As before, the bevel angle adjacent the leading tip 192 is greater than the bevel angle adjacent the trailing heel 194. However, the curvature is modified, with a shallow arc 196 adjacent the leading tip 192 which transitions into a less pronounced step 198 adjacent to the trailing heel 194. This configuration results in a slightly acute inner corner 200 at the trailing heel 194, as seen in Figure 12B. As with the reduced bevel angle of the embodiment of Figure 3, as long as the angle of the curved bevel at the trailing heel 194 is approximately 30° or less, the inner corner 200 will be sufficiently blunt to avoid damage to the passing IOL. In a preferred embodiment, the distal face forms an inner corner 200 with a wall of the lumen at the trailing heel 194 having an angle that is  $\geq 60^\circ$ . Indeed, several embodiments above described inner corner angles of 90° and greater, and the lower limit of 60° is considered to be the sharpest inner corner angle that can be utilized without creating significant risk of scratching the IOL.

[0048] Finally, the cartridge distal end 220 shown in Figures 13A-13B includes a partial planar bevel. More particularly, a majority of the distal face 222 lies flush with the plane of the bevel, which may be 40-45°, but is interrupted by a scoop or cutout 224 at the trailing heel 226. In other words, as seen in Figure 13B, the distal face 222 extends from a leading tip 228 up into proximity with the trailing heel 226, but is interrupted by the cutout 224. The cutout 224 extends a short distance down around the distal end 220, such as about 30° symmetrically from a central vertical plane. The cutout 224 may be formed at an angle perpendicular to the central axis of the tubular cartridge distal end 220, as shown, or may be slightly angled toward the bevel (up to about 30°) or even chamfered in an opposite direction to the bevel. The result is an inner corner angle that is less likely to scratch or otherwise damage the passing IOL. Moreover, the remaining portion of the distal end can remain as a planar bevel, which maintains ease of cartridge tip insertion into the wound and is proven effective in delivering the IOL. In the illustrated embodiment the inner corner angle is 90°. The cutout 224 can be viewed as an abbreviated chamfer in contrast to the variably chamfered embodiments described above.

[0049] The various solutions for cartridge distal ends provided herein permit the distal ends to have diameters down to about 1.4 mm, with a wall thickness of about 0.014 mm. Materials used for the IOL cartridges described herein include polypropylene, polycarbonate, polyurethane or other appropriate thermoplastics. The various shapes for the distal ends can be  
5 formed by molding or laser cutting. In particular, the variable chamfer geometries are especially well-suited to injection molding.

[0050] While the invention has been described in its preferred embodiments, it is to be understood that the words which have been used are words of description and not of limitation. Therefore, changes may be made within the appended claims without departing from the true  
10 scope of the invention.

WHAT IS CLAIMED IS:

1. A cartridge for receiving and delivering an intraocular lens to the inner eye, comprising:

a main body extending longitudinally from a proximal opening for receiving the intraocular lens to a distal end, and a lumen extending from the proximal opening to the distal end which defines a distal opening that is smaller than the intraocular lens, the distal end being beveled as seen in side view with a leading tip below and opposite a trailing heel, the distal end further defining a distal face between an exterior surface and the lumen, the distal face including at least one portion that is not flush with the beveled distal end as seen in side view.

2. The cartridge of claim 1, wherein the beveled distal end defines a straight bevel.

3. The cartridge of claim 1, wherein the beveled distal end defines a curved bevel.

4. The cartridge of claim 1, wherein the portion of the distal face that is not flush with the beveled distal end includes a chamfer formed in a cutout region.

5. The cartridge of claim 1, wherein the distal face is not flush with the beveled distal end around its entire periphery.

6. The cartridge of claim 5, wherein the entire distal face is chamfered.

7. The cartridge of claim 1, wherein the portion of the distal face that is not flush with the beveled distal end includes at least one portion that is rounded.

8. The cartridge of claim 7, wherein the entire distal face is rounded.

9. A cartridge for receiving and delivering an intraocular lens to the inner eye, comprising:

a main body extending longitudinally from a proximal opening for receiving the intraocular lens to a distal end, and a lumen extending from the proximal opening to the distal end which defines a distal opening that is smaller than the intraocular lens, the distal end being beveled as seen in side view with a leading tip below and opposite a trailing heel, the distal end further defining a distal face between an exterior surface and the lumen, the distal face forming an inner corner with a wall of the lumen at the trailing heel having an angle  $\phi \geq 60^\circ$ .

10. The cartridge of claim 9, wherein the distal face forms an inner corner with a wall of the lumen at the trailing heel having an angle  $\phi \geq 90^\circ$ .

11. The cartridge of claim 9, wherein the beveled distal end defines a straight bevel.

12. The cartridge of claim 9, wherein the beveled distal end defines a curved bevel.

13. The cartridge of claim 12, wherein the bevel angle adjacent the leading tip is greater than the bevel angle adjacent the trailing heel

14. The cartridge of claim 9, wherein the distal face includes a chamfer formed in a cutout region that is not flush with the beveled distal end.

15. The cartridge of claim 9, wherein the distal face is not flush with the beveled distal end around its entire periphery.

16. A cartridge for receiving and delivering an intraocular lens to the inner eye, comprising:

a main body extending longitudinally from a proximal opening for receiving the intraocular lens to a distal end, and a lumen extending from the proximal opening to the distal end which defines a distal opening that is smaller than the intraocular lens, the distal end having a curved bevel as seen in side view with a leading tip below and

opposite a trailing heel, wherein the bevel angle adjacent the leading tip is greater than the bevel angle adjacent the trailing heel.

17. The cartridge of claim 16, wherein the bevel angle adjacent the trailing heel is about  $0^\circ$ .

18. The cartridge of claim 16, wherein the distal face includes a chamfer formed in a cutout region that is not flush with the beveled distal end.

19. The cartridge of claim 16, wherein the distal face is not flush with the beveled distal end around its entire periphery.

20. The cartridge of claim 16, wherein the distal face forms an inner corner with a wall of the lumen at the trailing heel having an angle  $\phi \geq 60^\circ$ .

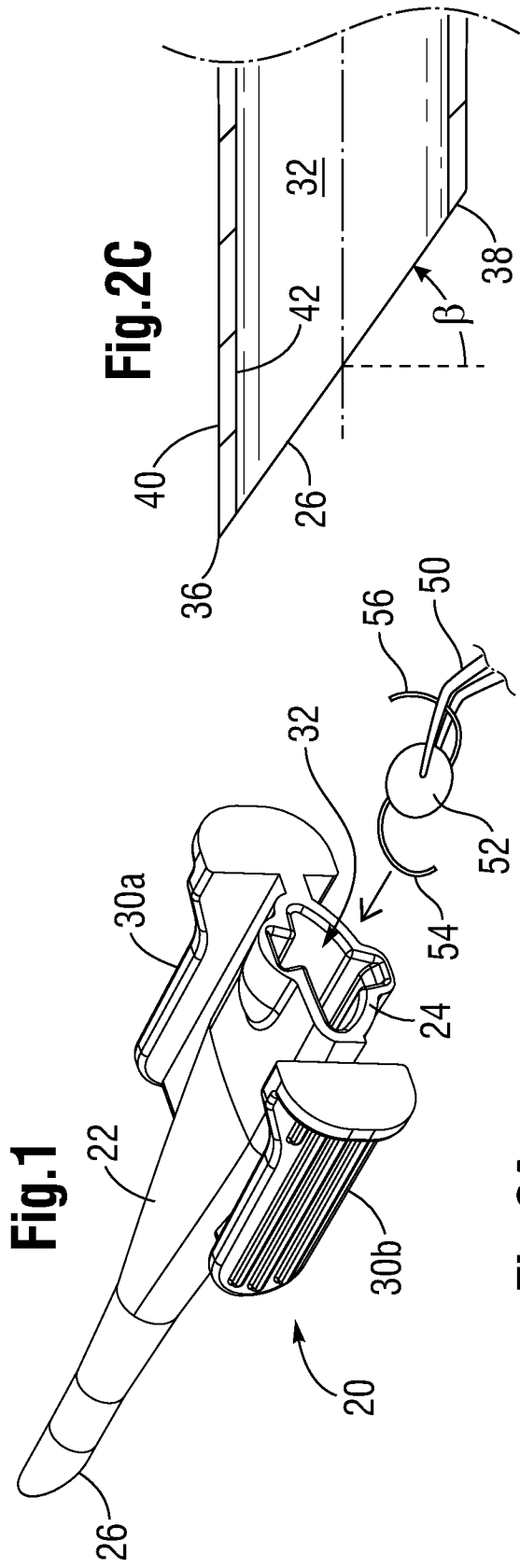


Fig. 2C

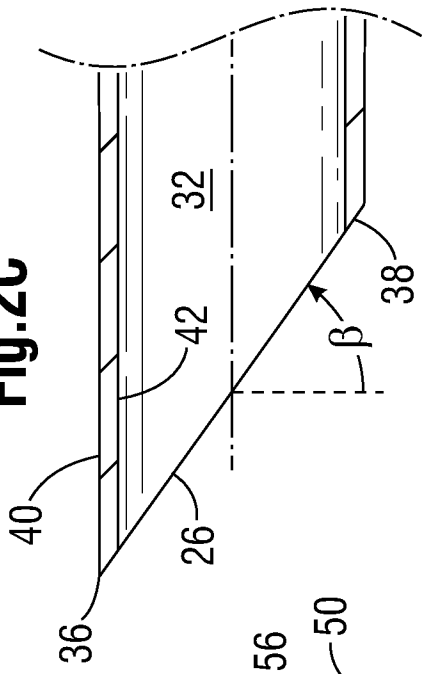


Fig. 2A

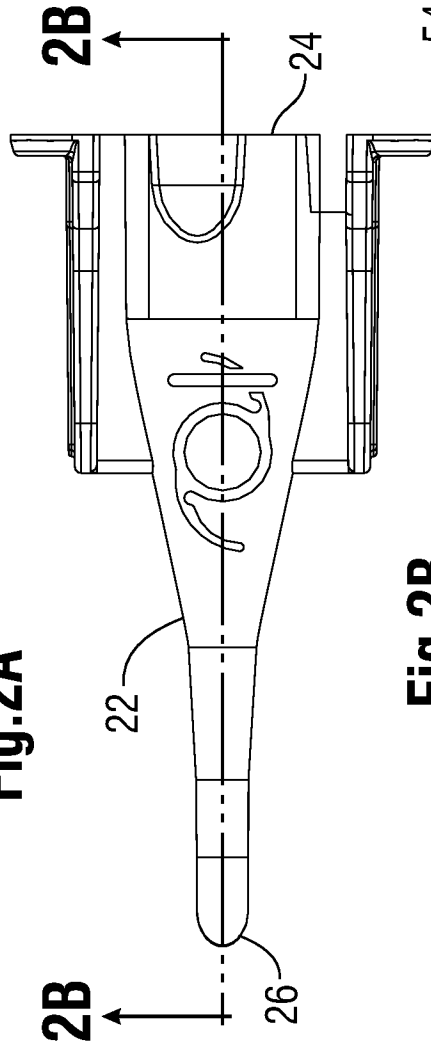
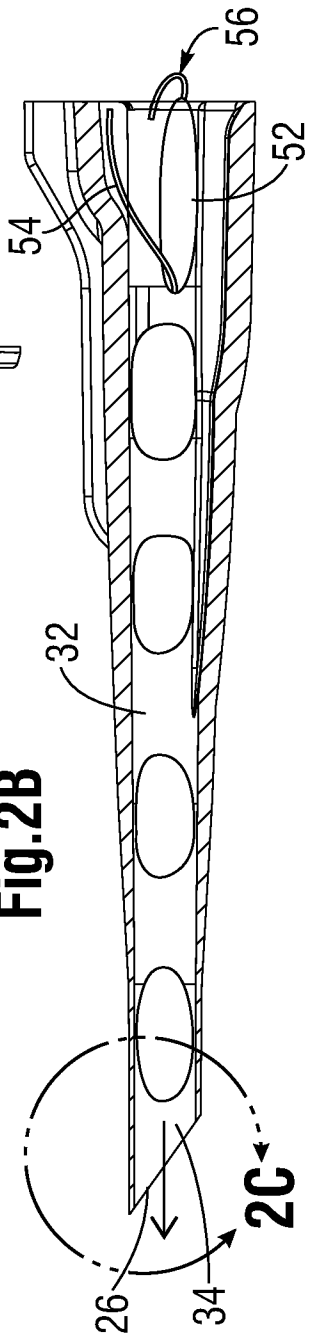
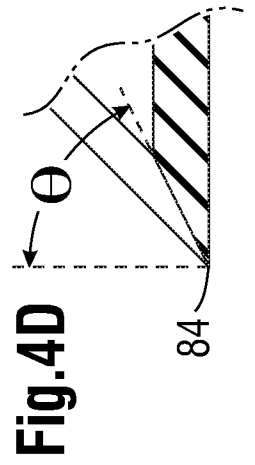
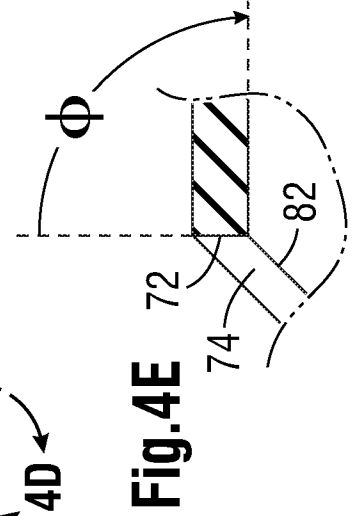
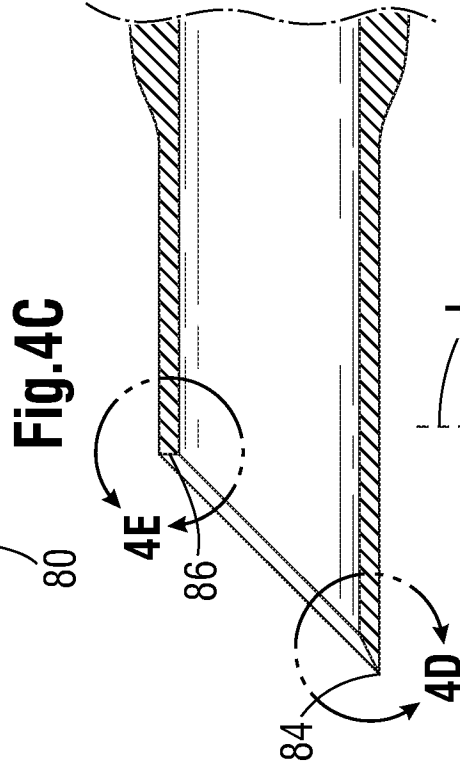
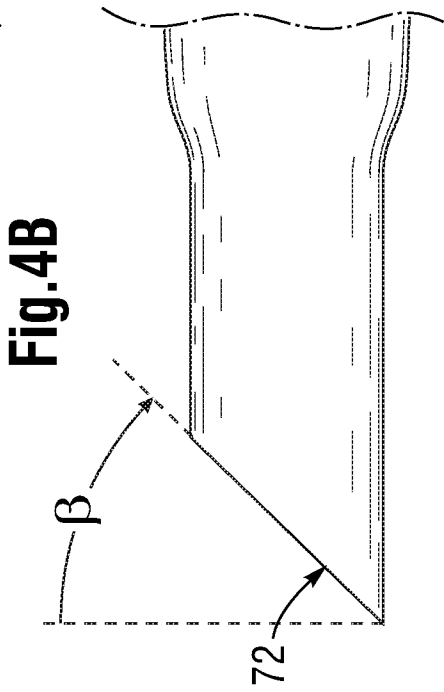
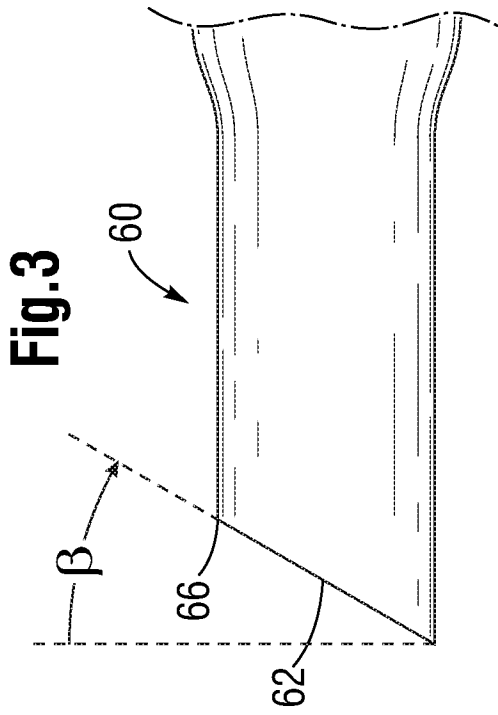
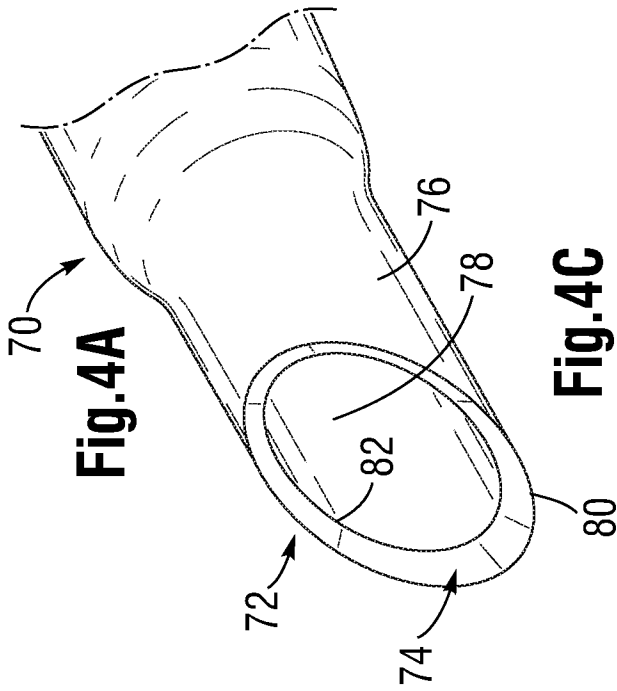
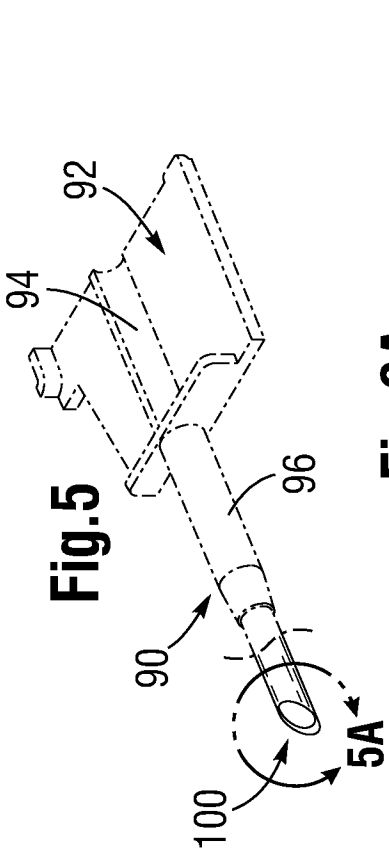


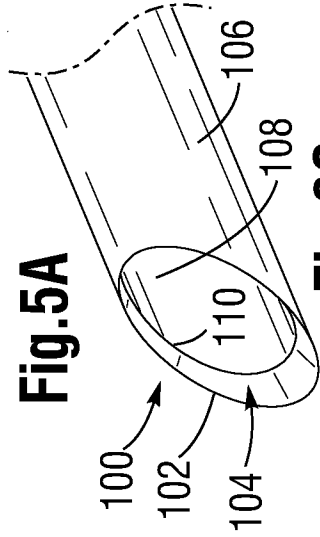
Fig. 2B



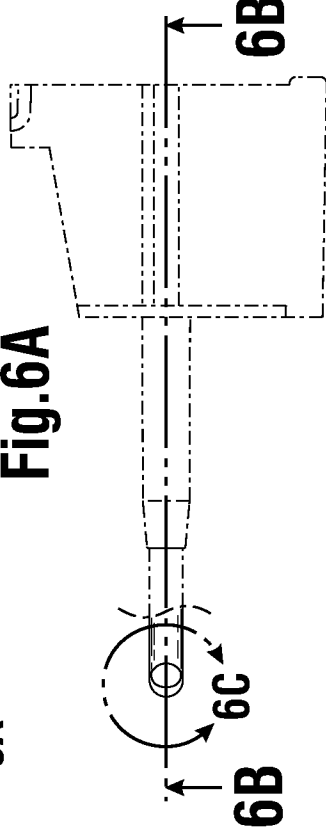




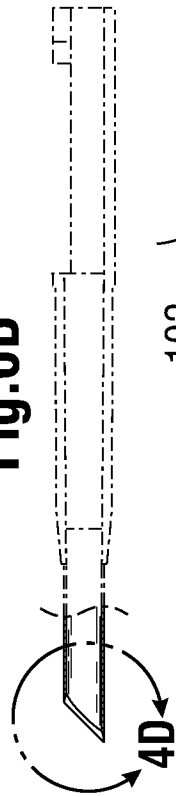
**Fig. 5A**



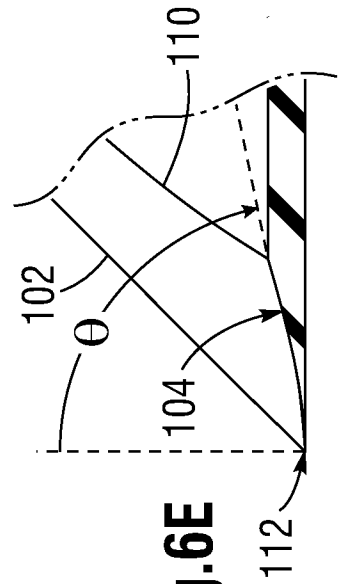
**Fig. 6A**



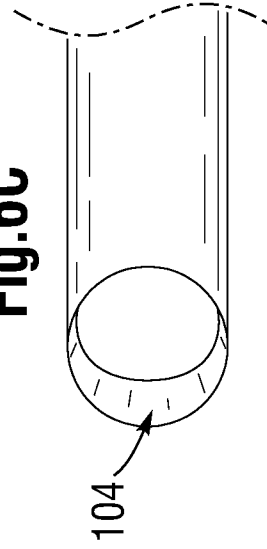
**Fig. 6B**



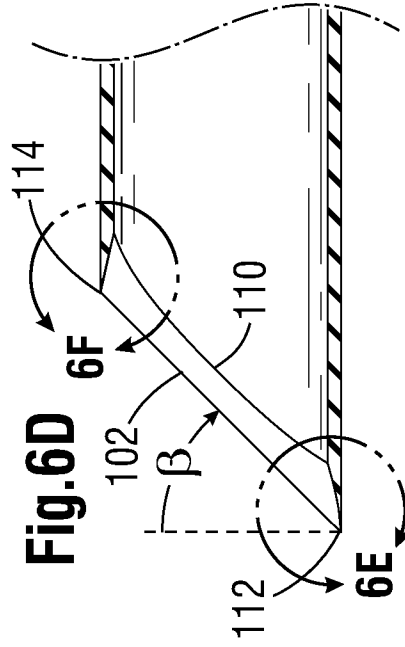
**Fig. 6E**



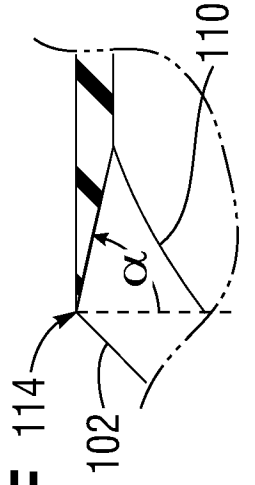
**Fig. 6C**

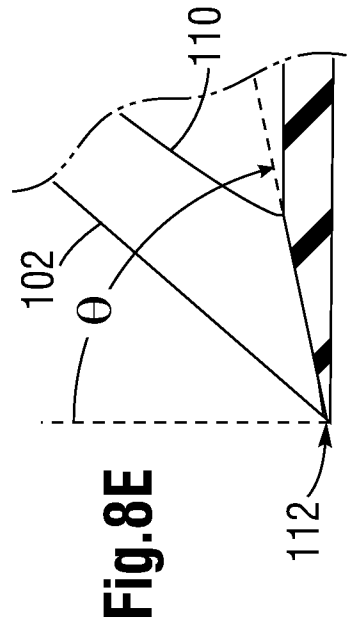
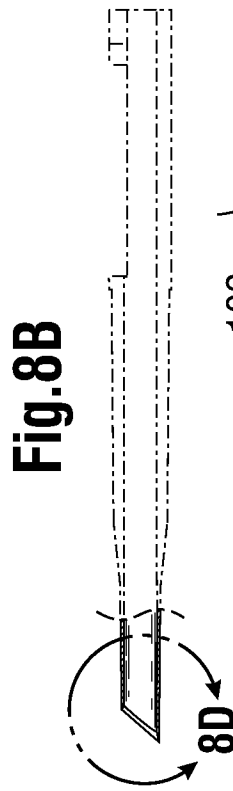
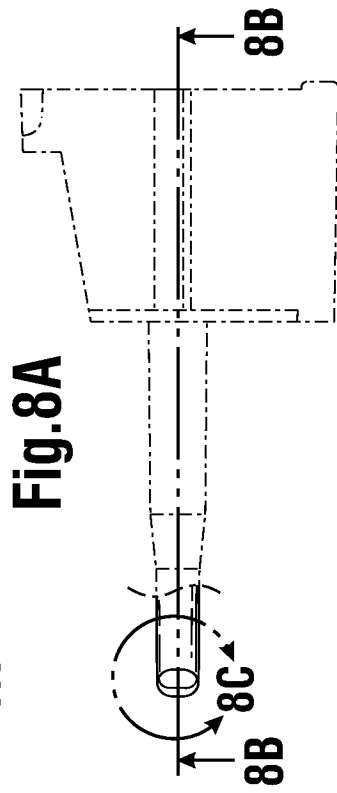
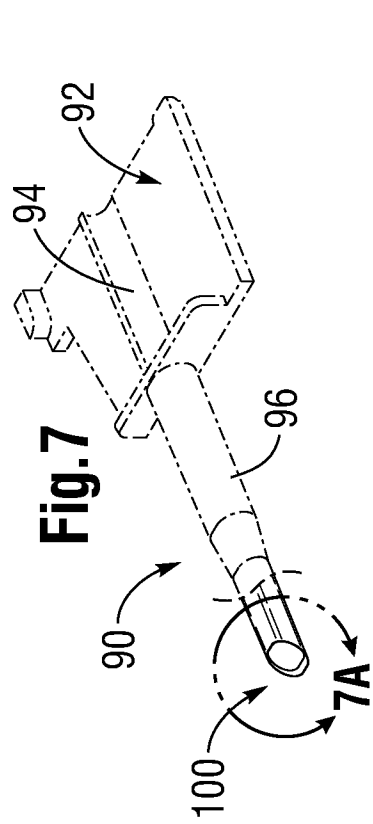
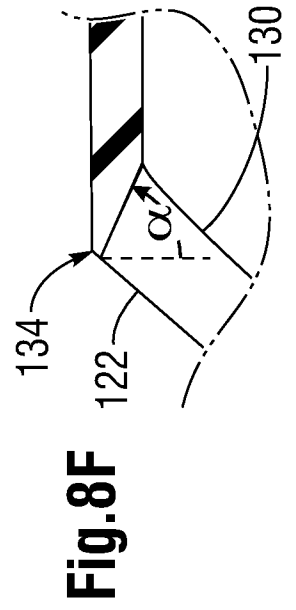
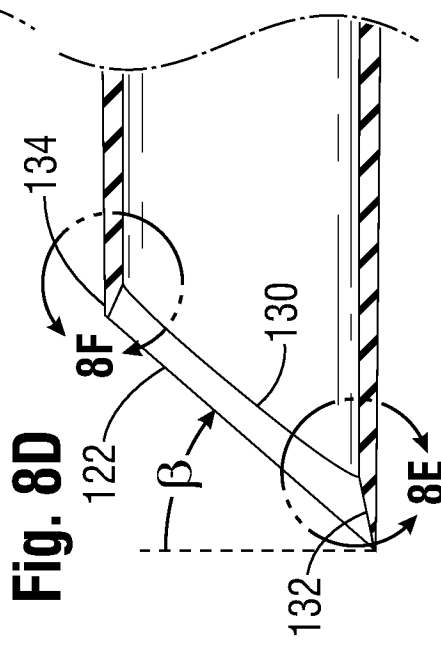
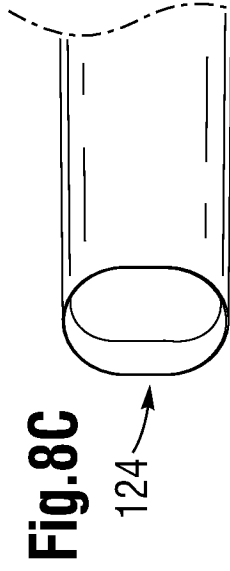
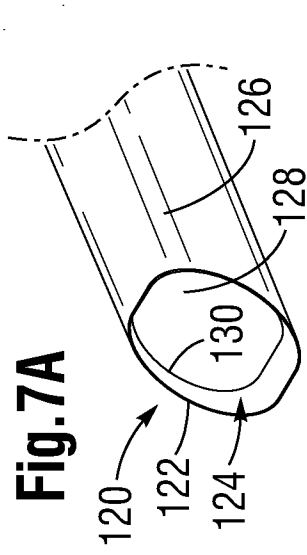


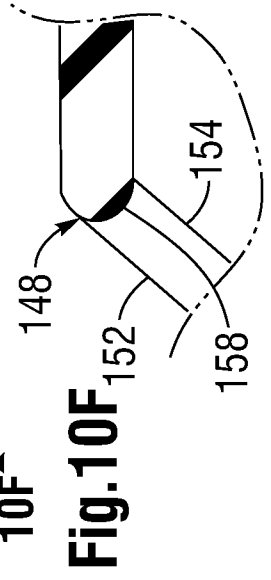
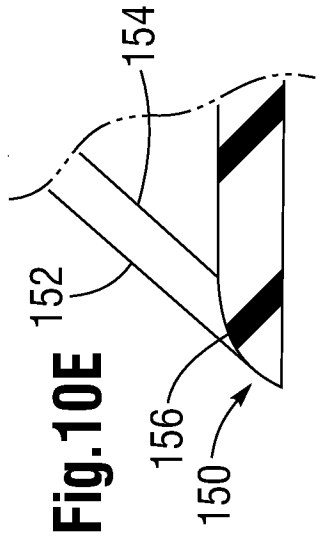
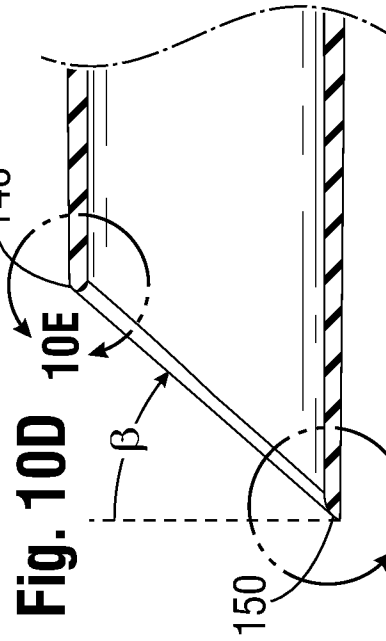
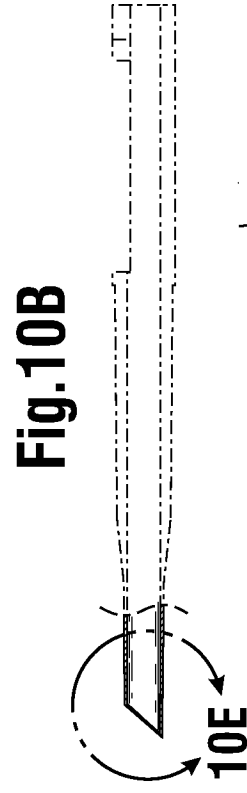
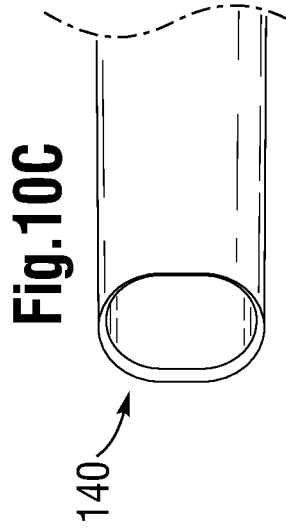
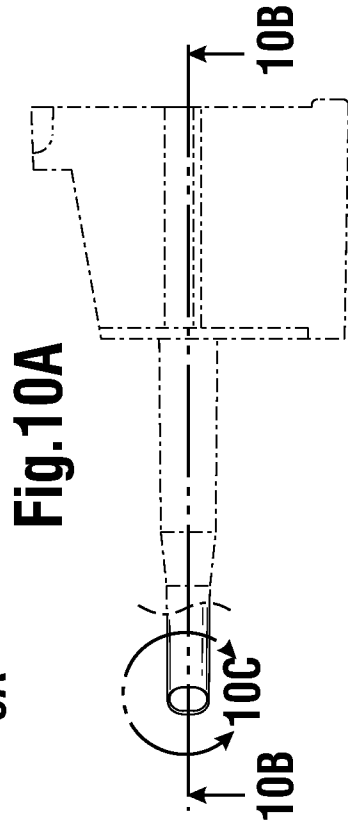
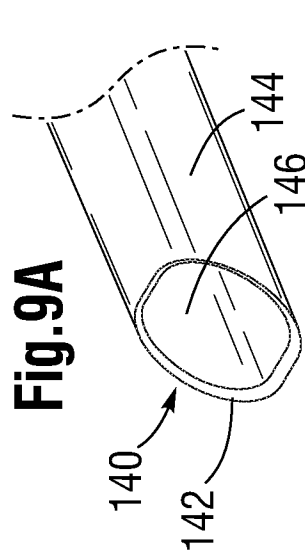
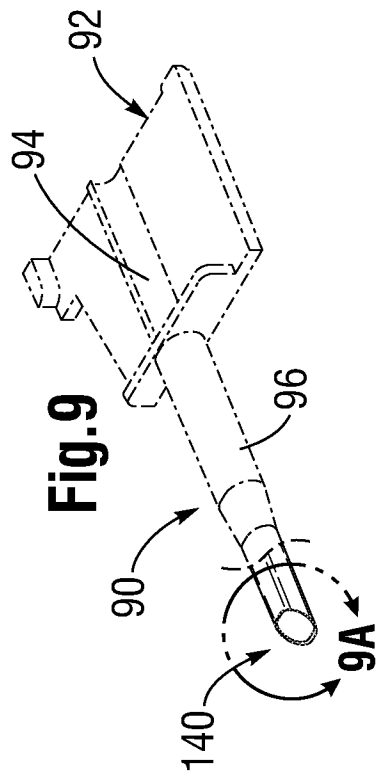
**Fig. 6D**



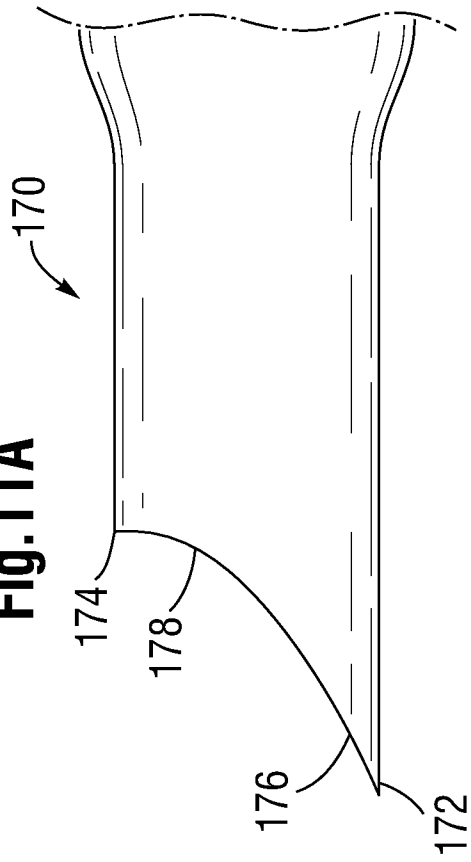
**Fig. 6F**



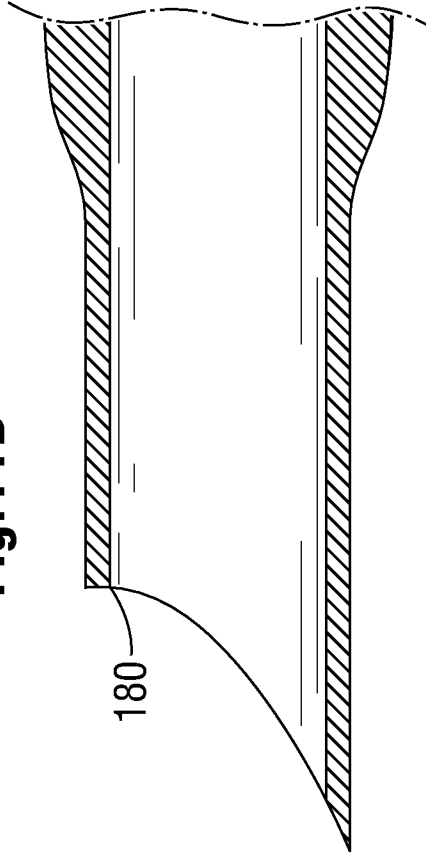




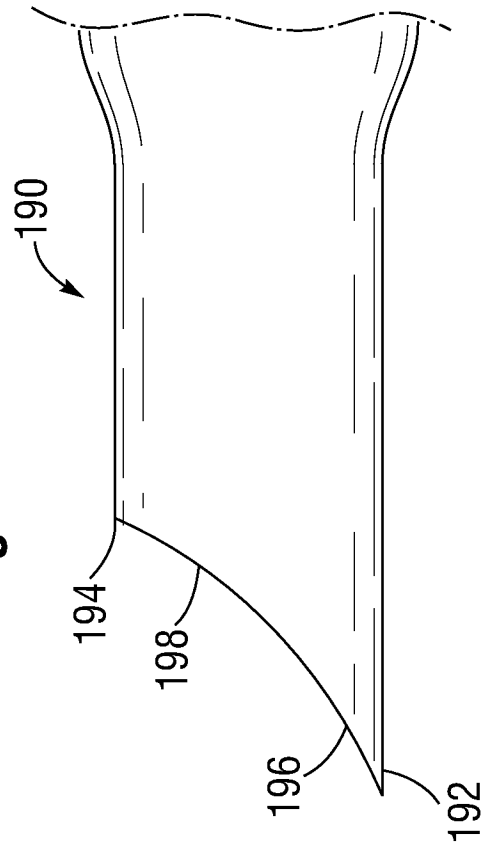
**Fig.11A**



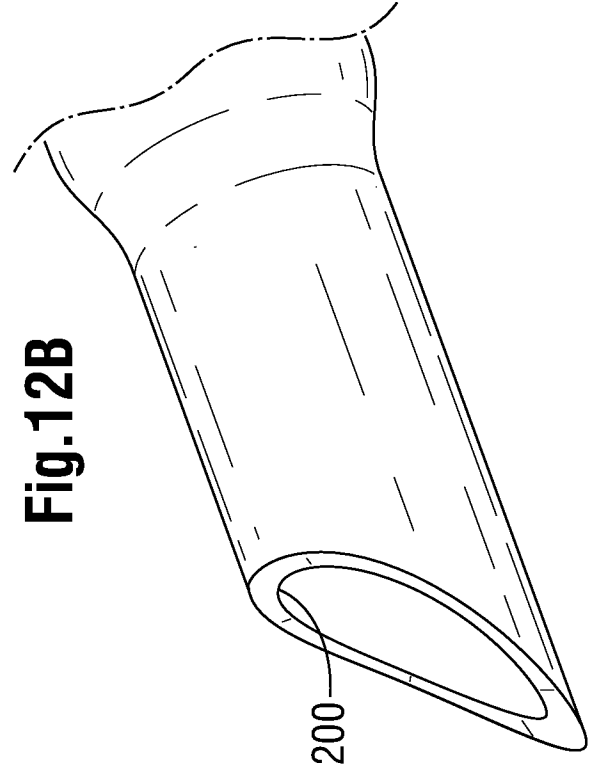
**Fig.11B**

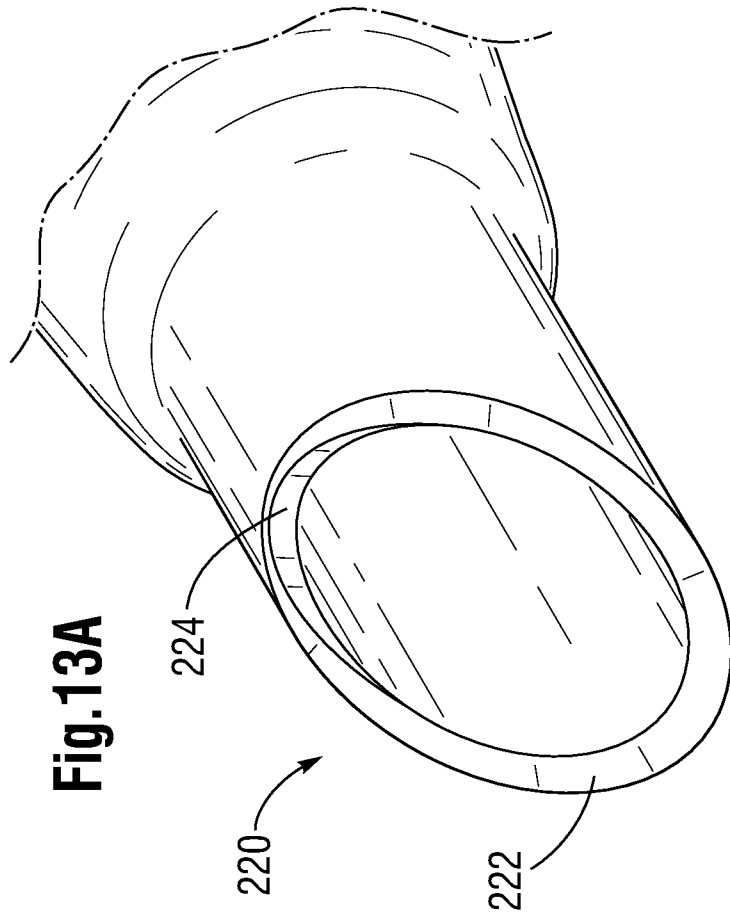


**Fig.12A**

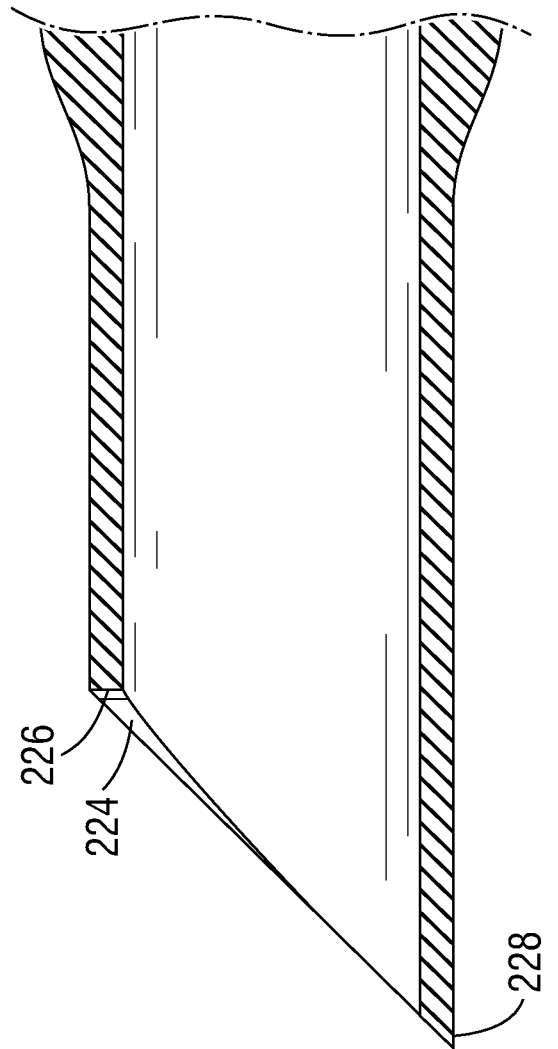


**Fig.12B**





**Fig. 13A**



**Fig. 13B**

# INTERNATIONAL SEARCH REPORT

International application No  
PCT/US2014/019987

<b>A. CLASSIFICATION OF SUBJECT MATTER</b> INV. A61F2/16 ADD.		
According to International Patent Classification (IPC) or to both national classification and IPC		
<b>B. FIELDS SEARCHED</b>		
Minimum documentation searched (classification system followed by classification symbols) A61F A61M		
Documentation searched other than minimum documentation to the extent that such documents are included in the fields searched		
Electronic data base consulted during the international search (name of data base and, where practicable, search terms used) EPO-Internal, WPI Data		
<b>C. DOCUMENTS CONSIDERED TO BE RELEVANT</b>		
Category*	Citation of document, with indication, where appropriate, of the relevant passages	Relevant to claim No.
X	US 2006/167466 A1 (DUSEK VACLAV [US]) 27 July 2006 (2006-07-27) paragraphs [0082] - [0091]; figure 3F -----	1-20
X	WO 2011/101683 A1 (RAYNER INTRAOCULAR LENSES LTD [GB]; DAVIES NATHANIEL [GB]) 25 August 2011 (2011-08-25) page 7, line 27 - page 8, line 8; figure 2 -----	1-20
X	WO 2012/081419 A1 (KOWA CO [JP]; MARUNAKA AKINORI [JP]; TANAKA TOSHIHIDE [JP]; NAGURA YUJ) 21 June 2012 (2012-06-21) See document below, filed in the regional phase in front of the EPO. & EP 2 641 568 A1 (KOWA CO [JP]) 25 September 2013 (2013-09-25) paragraphs [0029] - [0032], [0073] - [0080]; figures 3,14,15B -----	1-20
-/--		
<input checked="" type="checkbox"/> Further documents are listed in the continuation of Box C.	<input checked="" type="checkbox"/> See patent family annex.	
* Special categories of cited documents :		
"A" document defining the general state of the art which is not considered to be of particular relevance	"T" later document published after the international filing date or priority date and not in conflict with the application but cited to understand the principle or theory underlying the invention	
"E" earlier application or patent but published on or after the international filing date	"X" document of particular relevance; the claimed invention cannot be considered novel or cannot be considered to involve an inventive step when the document is taken alone	
"L" document which may throw doubts on priority claim(s) or which is cited to establish the publication date of another citation or other special reason (as specified)	"Y" document of particular relevance; the claimed invention cannot be considered to involve an inventive step when the document is combined with one or more other such documents, such combination being obvious to a person skilled in the art	
"O" document referring to an oral disclosure, use, exhibition or other means	"&" document member of the same patent family	
"P" document published prior to the international filing date but later than the priority date claimed		
Date of the actual completion of the international search	Date of mailing of the international search report	
28 April 2014	09/05/2014	
Name and mailing address of the ISA/ European Patent Office, P.B. 5818 Patentlaan 2 NL - 2280 HV Rijswijk Tel. (+31-70) 340-2040, Fax: (+31-70) 340-3016	Authorized officer  Chevalot, Nicolas	

# INTERNATIONAL SEARCH REPORT

International application No PCT/US2014/019987
---

C(Continuation). DOCUMENTS CONSIDERED TO BE RELEVANT

Category*	Citation of document, with indication, where appropriate, of the relevant passages	Relevant to claim No.
A	US 2002/188247 A1 (PEERY JOHN R [US]) 12 December 2002 (2002-12-12)  paragraphs [0036], [0039] - [0041]; figure 11  -----	1,5, 7-10,15, 16,19,20
A	BE 720 694 A (STILLEMANS, G.) 17 February 1969 (1969-02-17)  page 2, lines 27-33; figures 3,4  -----	1,5-10, 14-16, 18-20

# INTERNATIONAL SEARCH REPORT

Information on patent family members

International application No

PCT/US2014/019987

Patent document cited in search report	Publication date	Patent family member(s)	Publication date
US 2006167466	A1	27-07-2006	NONE
-----			
WO 2011101683	A1	25-08-2011	NONE
-----			
WO 2012081419	A1	21-06-2012	EP 2641568 A1 25-09-2013
			JP 2012125361 A 05-07-2012
			US 2013331853 A1 12-12-2013
			WO 2012081419 A1 21-06-2012
-----			
US 2002188247	A1	12-12-2002	US 7063681 B1 20-06-2006
			US 2002188247 A1 12-12-2002
-----			
BE 720694	A	17-02-1969	NONE
-----			