



(22) **Date de dépôt/Filing Date:** 2013/12/18

(41) **Mise à la disp. pub./Open to Public Insp.:** 2014/06/21

(45) **Date de délivrance/Issue Date:** 2016/06/07

(30) **Priorité/Priority:** 2012/12/21 (US13/724,852)

(51) **Cl.Int./Int.Cl.** *B61H 13/36* (2006.01)

(72) **Inventeur/Inventor:**  
WANG, WEIPING, US

(73) **Propriétaire/Owner:**  
AMSTED RAIL COMPANY, INC., US

(74) **Agent:** GOWLING WLG (CANADA) LLP

(54) **Titre : CAPUCHONS DE TIGE DE POUTRE DE FREIN**

(54) **Title: BRAKE BEAM PADDLE CAPS**

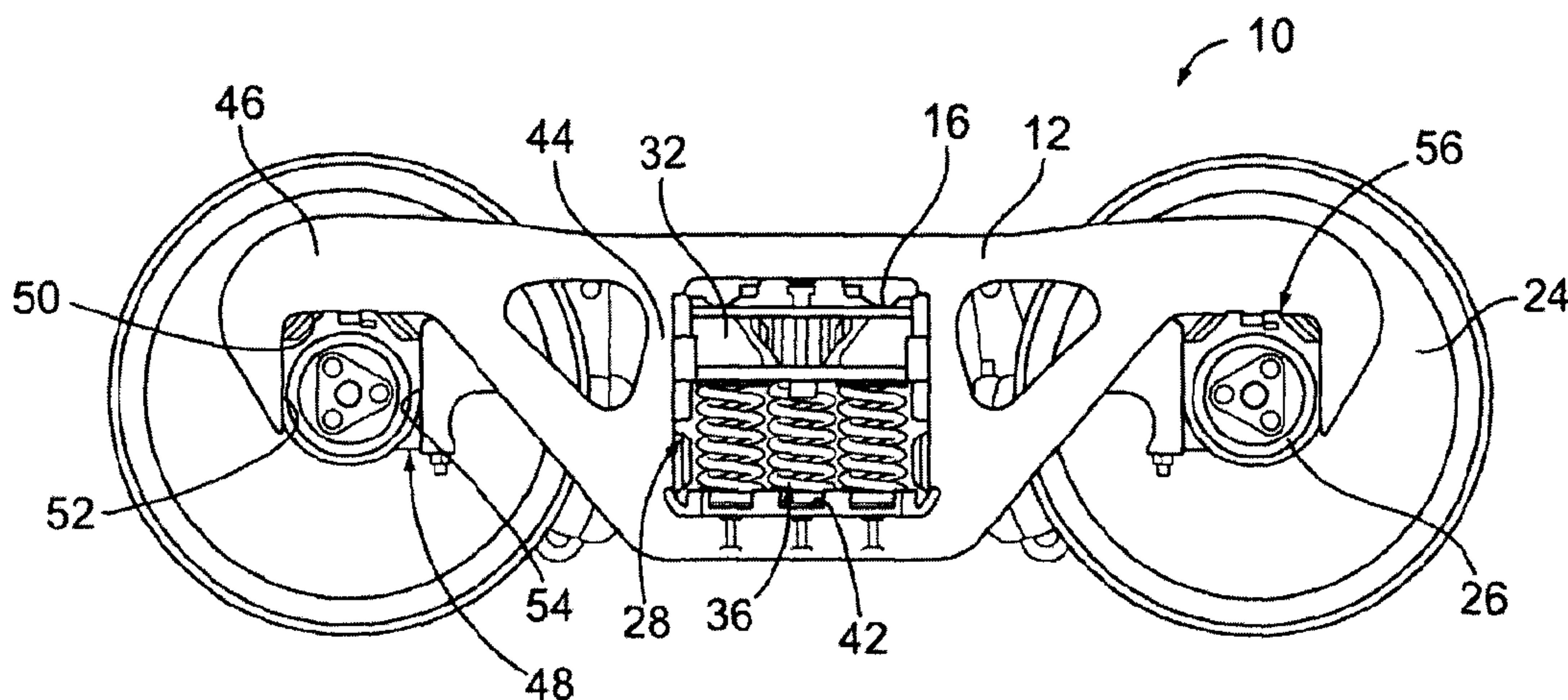

(57) **Abrégé/Abstract:**

A brake beam assembly for a railway car truck includes a brake beam configured to be mounted between opposed side frames of the railway car truck, a strut extending from the brake beam and brake heads coupled to the brake beam proximate to right hand and left hand ends thereof. Each brake head holds a brake shoe configured to engage a wheel of the railway car truck. Paddles extend exterior of the brake heads. The paddles have distal ends received in corresponding guide brackets of the side frames to guide movement of the brake beam. Paddle caps cover the distal ends of the paddles. The paddle caps are configured to be received in brake beam wear liners in corresponding side frames of the railway car truck. The paddle caps have a lower coefficient of friction than the paddles.

**BRAKE BEAM PADDLE CAPS****ABSTRACT OF THE DISCLOSURE**

A brake beam assembly for a railway car truck includes a brake beam configured to be mounted between opposed side frames of the railway car truck, a strut extending from the brake beam and brake heads coupled to the brake beam proximate to right hand and left hand ends thereof. Each brake head holds a brake shoe configured to engage a wheel of the railway car truck. Paddles extend exterior of the brake heads. The paddles have distal ends received in corresponding guide brackets of the side frames to guide movement of the brake beam. Paddle caps cover the distal ends of the paddles. The paddle caps are configured to be received in brake beam wear liners in corresponding side frames of the railway car truck. The paddle caps have a lower coefficient of friction than the paddles.

## BRAKE BEAM PADDLE CAPS

### BACKGROUND OF THE INVENTION

[0001] The subject matter herein relates to a railway car truck and, more particularly, to a brake beam assembly for a railway car truck.

[0002] In a railway car truck, two axles are held in a pair of laterally spaced side frames, with a bolster extending laterally between and supported on each side frame. The wheels are press fit on the axles, with the ends of the axles also fitted with a roller bearing assembly. The roller bearing assembly is fit into a bearing adapter that is fit into a pedestal jaw opening at the longitudinal end of each side frame. Each railway car truck also includes a braking system having two brake beams that act to transmit braking force through brake shoes to the outer tread of the railway wheels. The brake beams are attached to the side frames in corresponding guide brackets having wear liners therein. For example, paddles extending from ends of the brake beams are received in the wear liners and are movable therein during application of the braking system. Typically, wear plates are positioned within the guide brackets to eliminate wear on the guide brackets.

[0003] During operation, the wear plates deteriorate over time. For example, the friction between the paddles and the wear liners eventually cause the wear plates to need replacement. Replacement of the wear liners requires the railway car truck to be taken off line and disassembled. The paddles are typically made from a hard material, such as a cast steel that wears over time against the wear plates. To protect the paddles, the paddles are typically flame hardened to prevent wear on the paddles. Such process adds to the overall cost of manufacture of the brake beam assembly and to the overall manufacture time of the brake beam assembly. Additionally, over time the paddles themselves may need replacement.

[0004] A need exists for an improved railway car truck that can reduce the friction and wear between the brake beam assembly and the wear liners held by the side frames.

**BRIEF DESCRIPTION OF THE INVENTION**

[0005] In one embodiment, a brake beam assembly for a railway car truck is provided that includes a brake beam configured to be mounted between opposed side frames of the railway car truck, a strut extending from the brake beam and brake heads coupled to the brake beam proximate to right hand and left hand ends thereof. Each brake head holds a brake shoe configured to engage a wheel of the railway car truck. Paddles extend exterior of the brake heads. The paddles have distal ends received in corresponding guide brackets of the side frames to guide movement of the brake beam. Paddle caps cover the distal ends of the paddles. The paddle caps are configured to be received in brake beam wear liners in corresponding side frames of the railway car truck. The paddle caps have a lower coefficient of friction than the paddles.

[0006] In another embodiment, a railway car truck is provided having a bolster having laterally opposite ends and two side frames transverse to the bolster and supporting the opposite ends of the bolster. Each side frame has a guide bracket on an inner side of the side frame. Brake beam wear liners are received in corresponding guide brackets on the side frames. The brake beam wear liners each have a pocket. A brake beam assembly is supported on the bolster and side frames. The brake beam assembly includes a brake beam mounted between the side frames, a strut extending from the brake beam and brake heads coupled to the brake beam. Each brake head holds a brake shoe configured to engage a wheel of the railway car truck. Paddles are provided at opposite ends of the brake beam assembly. The paddles are received in corresponding guide brackets to guide movement of the brake beam. Paddle caps cover the paddles and are received in pockets of corresponding wear liners. The paddle caps have a lower coefficient of friction than the paddles.

[0007] Optionally, the paddle caps reduce the friction and wear on the brake beam wear liner as compared to the paddles wearing on the brake beam wear liners. The paddle caps may surround the paddles to ensure that the paddles do not engage the brake beam wear liners. The paddle caps may be manufactured from a

material having a substantially similar coefficient of friction as the brake beam wear liner. The paddle caps may be manufactured from the same material as the brake beam wear liner.

[0008] Optionally, each paddle cap may include a top, a bottom, and a distal end. Each brake beam wear liner may include an upper surface, a lower surface and a base defining the corresponding pocket. The paddle cap may be received in the brake beam wear liner such that the top faces the upper surface, the bottom faces the lower surface and the distal end faces the base.

[0009] Optionally, each paddle cap may have a cavity that receives a distal end of the corresponding paddle. The paddle caps may be held on the paddles by an interference fit. Each paddle cap may include rounded edges and corners facing the brake beam wear liner. An exterior surface of each paddle cap may engage the corresponding brake beam wear liner to guide movement of the paddles. The paddle caps may take up a portion of a gap between the paddle and the brake beam wear liner.

#### BRIEF DESCRIPTION OF THE DRAWINGS

[0010] Figure 1 is a side view of a railway car truck formed in accordance with an exemplary embodiment;

[0011] Figure 2 is a top view of the railway car truck shown in Figure 1;

[0012] Figure 3 is a perspective view of the railway car truck shown in Figure 1;

[0013] Figure 4 is a side view of a portion of the railway car truck;

[0014] Figure 5 is a top, partial sectional view of a portion of the railway car truck;

[0015] Figure 6 illustrates a portion of the brake beam assembly showing a paddle cap poised for loading onto a corresponding paddle of the brake beam assembly.

#### DETAILED DESCRIPTION OF THE INVENTION

[0016] Referring now to Figures 1-3, a railway car truck 10 is shown. The railway car truck 10 includes two laterally spaced side frames 12 and 14, between which a bolster 16 extends. Each of the side frames 12, 14 and bolster 16 are usually a cast steel unitary structure. Various internal ribs and supports lend strength, along with a savings in overall weight for each of such cast steel truck components.

[0017] Axles 20 and 22 extend laterally between the side frames 12, 14. Railway wheels 24 are press fit on the ends of the axles 20, 22. Roller bearing assemblies 26 are also provided on the ends of the axles 20, 22. The side frames 12, 14 include side frame openings 28 aligned with the bolster 16.

[0018] The bolster 16 includes bolster ends 32 and 34, which extend through the side frame openings 28. Spring groups 36 support the bolster ends 32 on a side frame lower support 42. The side frames 12, 14 include vertical columns 44 that are longitudinally spaced and form the side frame openings 28 therebetween. The lower support section 42 has various raised structures adapted to position the spring group 36 thereupon.

[0019] The side frames 12, 14 include laterally spaced pedestal jaws 46 which are the further most lateral extent of the side frames 12, 14. Each pedestal jaw 46 forms a pedestal jaw opening 48, which is defined by a roof section 50, an outer wall 52, and an inner wall 54. The pedestal jaw opening 48 is adapted to receive a bearing adapter 56 therein. The bearing adapters 56 rest on the roller bearing assemblies 26.

[0020] The railway car truck 10 includes a brake system 60 having brake heads 62 that support brake shoes 64. The brake system 60 is operated to press the brake shoes 64 against the railway wheels 24. The brake heads 62 may be

fabricated or cast steel devices. The brake system 60 is supported from the side frames 12, 14 and the bolster 16 and is illustrated with additional reference to Figure 4.

[0021] The bolster 16 includes on its upper surface a bolster center plate 66, which includes a bolster center plate wear liner 68. Also included on the upper surface of the bolster 16 is a pair of laterally spaced side bearings 70.

[0022] Figure 4 is a side view of a portion of the railway car truck 10 illustrating a portion of an inner side 80 of the side frame 14. The side frame 14 includes guide brackets 82 extending inward from the side frame 14. Optionally, the guide brackets 82 are integrally formed with the side frame 14. The guide brackets 82 are positioned along the vertical column 44 proximate to the side frame opening 28. The guide brackets 82 are positioned proximate to the lower support section 42 on each side of the side frame opening 28. Similarly, the side frame 12 (shown in Figures 2 and 3) includes a pair of guide brackets that are substantially similar to the guide brackets 82.

[0023] Each guide bracket 82 includes a pocket 84 that is surrounded by an upper wall 86 and a lower wall 88. The upper and lower walls 86, 88 are substantially parallel to one another and project from the side frame 14 to define the pocket 84. In an exemplary embodiment, the guide bracket 82 has an open side furthest from the side frame 14 that provides access to the pocket 84. The open side extends between the upper and lower walls 86, 88. The pocket 84 receives a brake beam wear liner 90 which receives a portion of the brake system 60 (shown in Figure 3). For example, the brake beam wear liners 90 receive paddles 120 and paddle caps 122 of the brake system 60 as described in further detail below. In an exemplary embodiment, the guide brackets 82 may conform to AAR standard S-366. The AAR standards call for the guide bracket 82 to be inclined to the horizontal at an angle of 14° for 40, 50, 70, and 90-100 ton cars, and at an angle of 16° for 125 ton cars.

[0024] The brake beam wear liners 90 each include a pocket 92 defined by an upper surface 94, a lower surface 96 and a base 98 at the interior of the

pocket 92. The brake beam wear liners 90 protect wear on the guide brackets 82. The break beam wear liners 90 are replaceable once worn, such as by removing the break beam wear liners 90 from the guide brackets 82 and inserting new break beam wear liners 90 therein. However, the railway car truck 10 must be taken out of service for such repair. Reducing wear on the break beam wear liners 90 reduces the frequency of replacement allowing longer service life for the railway car truck 10.

[0025] In an exemplary embodiment, each brake beam wear liner 90 is manufactured from a metal material, such as a cast steel material. Other types of metal materials may be used in alternative embodiments. A metal material used for the brake beam wear liner 90 may be manufactured by a process other than casting, such as stamping and forming the brake beam wear liner 90. Alternatively, the brake beam wear liner 90 may be fabricated from a synthetic material, such as a nylon material, a high molecular weight polyethylene material, and the like. Optionally, impact resistant synthetic materials may be used. Other types of synthetic materials may be used in alternative embodiments. The break beam wear liner 90 may be manufactured from a material selected to provide certain characteristics, such as reduced friction or wear characteristics as compared to the material of the guide bracket 82.

[0026] Figure 5 is a top, partial sectional view of a portion of the railway car truck 10 illustrating brake beam wear liners 90 received in corresponding guide brackets 82 of the side frames 12, 14. Figure 5 also illustrates a portion of the bolster 16, the railway wheels 24 and a portion of the brake system 60. The brake system 60 includes brake beam assemblies 100 each including a brake beam 102, a strut 104, and brake heads 62 coupled to ends of the brake beam 102 and strut 104.

[0027] The brake beam 102 is generally elongated between a right hand end 106 and a left hand end 108. The brake beam 102 extends laterally between the side frames 12, 14. The brake shoes 64 are coupled to the brake heads 62, which are provided proximate to the ends 106, 108 of the brake beam 102, generally aligned with the railway wheels 24.

[0028] The strut 104 includes a right hand end 110 and a left hand end 112. In an exemplary embodiment, the strut 104 is separate and discrete from the brake beam 102 and is coupled to the brake beam 102 with the ends 110, 112 proximate to the ends 106, 108, respectively. Alternatively, the strut 104 may be integral with the brake beam 102, such as formed as part of a common casting process. The strut 104 extends at acute angles from the brake beam 102 to an apex at a center portion. A standoff section 114 extends from a center portion of the brake beam 102 to the apex of the strut 104.

[0029] The brake beam 102, strut 104 and standoff section 114 are typically comprised of structural steel, and may be in the form of a hollow structural steel sections. One or more levers 116 are connected to the brake beam assembly 100, such as to the standoff sections 114, to actuate the brake beam assembly 100 during braking.

[0030] The brake beam wear liners 90 are shown loaded into the guide brackets 82. Ends of the brake beam assembly 100 are configured to extend into the brake beam wear liners 90. For example, the paddles 120 and paddle caps 122 (shown in greater detail in Figure 6) may be provided at the opposite ends of the brake beam assembly 100 to extend into the brake beam wear liners 90. The paddles 120 are extensions at the end of the brake beam assembly 100. The paddles 120 may be integrally formed with the brake beam 102, the strut 104 and/or the brake heads 62. In other alternative embodiments, the paddles 120 may be separate and discrete from the other components of the brake beam assembly 100. For example, the paddles 120 may be coupled, such as fastened, to the brake beam 102, the strut 104 and/or the corresponding brake head 62. The paddle caps 122 are coupled to the paddles 120 to reduce friction and wear between the brake beam assembly 100 and the brackets 82 during use of the brake system 60.

[0031] Figure 6 illustrates a portion of the brake beam assembly 100 showing one end thereof illustrating one of the paddle caps 122 poised for loading onto the corresponding paddle 120. The paddle 120 includes a distal end 124. The

paddle 120 includes a top 126 and a bottom 128. The paddle 120 includes first and second edges 130, 132, which may define a front and a rear of the paddle 120.

[0032] The paddle cap 122 is sized and shaped to cover at least the end of the paddle 120. The paddle cap 122 provides a sacrificial layer over the paddle 120. The paddle cap 122 includes a cavity 134 that receives the paddle 120. The cavity 134 is defined by an interior surface 136 that engages the exterior of the paddle 120 when coupled thereto. Optionally, the paddle cap 122 may be held on the paddle 120 by an interference fit. Alternatively, the paddle cap 122 may be secured by other means or processes, including bonding, welding, using fasteners, using latches, or other means.

[0033] The paddle cap 122 includes a top 138, a bottom 140, a distal end 142 and first and second edges 144, 146. The first and second edges 144, 146 may define a front and a rear of the paddle cap 122. In an exemplary embodiment, the paddle cap 122 may have rounded edges and corners at the intersections of the top 138, bottom 140, distal end 142 and first and second edges 144, 146. The rounded edges may reduce damage to the brake beam wear liner 90 when moving therein. The rounded edges may reduce the chance of lockup with the brake beam wear liner 90 when moving therein.

[0034] The paddle cap 122 may be manufactured from a material having a low coefficient of friction. The paddle cap 122 may be manufactured from a material having a lower coefficient of friction than the paddle 120. The paddle cap 122 may be manufactured from a material that is less abrasive than the paddle 120. The paddle cap 122 may be manufactured from a material having a coefficient of friction that is less than half the coefficient of friction of the paddle 120. Optionally, the paddle cap 122 may be manufactured from the same or a similar material as the brake beam wear liner 90 (shown in Figure 5). In an exemplary embodiment, the paddle cap 122 may be manufactured from a polymer material, such as a synthetic material, a nylon material, a high molecular weight polyethylene material, and the like. The paddle cap 122 may be molded or may be manufactured by other processes.

[0035] Returning to Figure 5, during operation of the brake system 60, the brake beam assemblies 100 may be pressed toward the corresponding railway wheels 24 to apply braking pressure to the railway wheels 24. The levers 116 actuate the brake assemblies 100 during braking. Movements of the brake beam assemblies 100 are guided by the brake beam wear liners 90. For example, the brake beam wear liners 90 limit movement of the brake beams 102 along a generally linear path toward, and away from, the railway wheels 24. The brake beams 102 have a linear range of motion defined by the brake beam wear liners 90.

[0036] The brake beam assemblies 100 are not physically connected to the side frames 12, 14. Rather, the brake beam assemblies 100 are free-floating between the side frames 12, 14. The brake beam assemblies 100 have an axial length measured between the distal ends 142 of the paddle caps 122. The axial length of each brake beam assembly 100 is selected to fit between the brake beam wear liners 90. The brake beam wear liners 90 associated with a particular brake beam assembly 100 are spaced apart from one another by a lateral distance that is longer than the axial length of the brake beam assembly 100. As such and with the low coefficient of friction and round edges of paddle caps 122, binding of the brake beam assembly 100 is reduced or eliminated.

[0037] During operation of the brake system 60, the brake beam assemblies 100 are actuated between retracted positions and advanced positions. In the retracted position, the brake beams 102 are positioned closer to the bolster 16. In the advanced position, the brake beams 102 are actuated away from the bolster 16, thus pushing the brake shoes 64 toward the corresponding railway wheels 24 to apply braking pressure to the railway wheels 24. The levers 116 actuate the brake assemblies 100 during braking. Movement of the brake beam assemblies 100 is guided by the brake beam wear liners 90. For example, the brake beam wear liners 90 limit movement of the paddles 120 and paddle caps 122, and thus the brake beams 102, along a generally linear path toward, and away from, the railway wheels 24 between the advanced and retracted positions. The brake beams 102 have a linear range of motion defined by the brake beam wear liners 90.

[0038] During operation of the brake system 60, the paddle caps 122 reduce the friction between the brake beam assembly 100 and the brackets 82. More braking force can be applied to the wheels 24 as opposed to using a portion of such force to overcome the forces to move the brake beam assembly 100 from the retracted position to the advanced position. As compared to conventional systems without paddle caps, the paddle caps 122 protect the paddles 120 and reduce wear on the paddles 120 and on the brake beam wear liners 90. For example, conventional brake systems put the paddle in direct contact with the brake beam wear liner 90 and the hardened, rough surface of the paddle increases wear on the brake beam wear liner 90. The steel-polymer (or steel-steel) sliding surface between conventional brake systems and the brake beam wear liner 90 has a high coefficient of friction and thus increased resistance to braking action, which can create more stress and wear on the brake beam wear liner 90. Increased resistance may reduce the braking efficiency and may reduce the service life of the brake pads due to heavy drag.

[0039] The brake system 60, with the paddles caps 122, provides a polymer-polymer (or polymer-steel) sliding surface between the brake beam assembly 100 and the brake beam wear liner 90, which reduces friction and wear. Reduced wear over time on the components of the railway car truck 10 increases the service life of the railway car truck 10. The reduction in friction reduces drag when the brakes are released, which may increase the service life of the brake pads 64. Additionally, providing the paddle caps 122 may reduce a cost of manufacture of the brake beam assembly 100 by eliminating the need to flame harden the paddles 120, as is typical of conventional brake beam assemblies to prevent wear of the paddles of such assemblies. Flame hardening is a process that adds expense to the manufacture of the paddles 120, and eliminating the need for such process may reduce the overall cost of manufacturing the paddles 120 and/or the brake beam 102.

[0040] The paddle caps 122 may take up portions of gaps that would otherwise exist between the paddles 120 and the brake beam wear liners 90. For example, portions of gaps between the paddles 120 and the bases 98 of the brake beam wear liners 90. By partially filling such gaps, the paddle caps 122 may help

center or align the brake beam assembly 100 between the side frames 12, 14 and prevent binding of either end of the paddles 120 with the brake beam wear liners 90. For example, the brake beam assembly 100 may move freely and squarely between advanced positions and retracted positions as the brake beam assembly 100 is actuated and released, and apply braking force evenly on both brake shoes 64. Holding the brake beam assembly 100 in position may further prevent the railway wheels 24 from tilting causing premature wear of the wheels 24 and rail tracks. The radiused or curved ends of the paddle caps 122 may reduce friction and/or damage between the paddle caps 122 and the brake beam wear liners 90. Having the distal ends 142 of the paddle caps 122 parallel to the base 98 may reduce friction and/or damage between the paddle caps 122 and the brake beam wear liners 90, for example by ensuring a surface as opposed to an edge engages the brake beam wear liners 90.

[0041] It is to be understood that the above description is intended to be illustrative, and not restrictive. For example, the above-described embodiments (and/or aspects thereof) may be used in combination with each other. In addition, many modifications may be made to adapt a particular situation or material to the teachings of the invention without departing from its scope. Dimensions, types of materials, orientations of the various components, and the number and positions of the various components described herein are intended to define parameters of certain embodiments, and are by no means limiting and are merely exemplary embodiments. Many other embodiments and modifications within the scope of the claims will be apparent to those of skill in the art upon reviewing the above description. The scope of the invention should, therefore, be determined with reference to the appended claims, along with the full scope of equivalents to which such claims are entitled. In the appended claims, the terms "including" and "in which" are used as the plain-English equivalents of the respective terms "comprising" and "wherein." Moreover, in the following claims, the terms "first," "second," and "third," etc. are used merely as labels, and are not intended to impose numerical requirements on their objects.

## WHAT IS CLAIMED IS:

1. A railway car truck comprising:

a bolster having laterally opposite ends;

two side frames transverse to the bolster and supporting the opposite ends of the bolster, each side frame having a guide bracket on an inner side of the side frame;

brake beam wear liners received in corresponding guide brackets on the side frames, the brake beam wear liner having a pocket;

a brake beam assembly supported on the bolster and side frames, the brake beam assembly comprising:

a brake beam mounted between the side frames;

a strut extending from the brake beam;

brake heads coupled to the brake beam, each brake head holding a brake shoe configured to engage a wheel of the railway car truck;

paddles at opposite ends of the brake beam assembly, the paddles being received in corresponding guide brackets to guide movement of the brake beam;

and

paddle caps covering the paddles, the paddle caps being received in pockets of corresponding wear liners, the paddle caps having a lower coefficient of friction than the paddles, wherein the paddle caps are manufactured from a synthetic material chosen from a nylon, or a high molecular weight polyethylene having a substantially similar coefficient of friction as the brake beam wear liner to reduce wear on the brake beam wear liner.

2. The railway car truck of claim 1, wherein the paddle caps are

manufactured from the same material as the brake beam wear liner.

3. The railway car truck of claim 1, wherein each paddle cap has a cavity that receives a distal end of the corresponding paddle.

4. The railway car truck of claim 1, wherein each paddle cap includes a top, a bottom, and a distal end, and wherein each brake beam wear liner includes an upper surface, a lower surface and a base defining the corresponding pocket, the paddle cap being received in the brake beam wear liner such that the top faces the upper surface, the bottom faces the lower surface and the distal end faces the base.

5. The railway car truck of claim 1, wherein each paddle cap includes rounded edges and corners facing the brake beam wear liner.

6. The railway car truck of claim I, wherein the paddle caps surround the paddles to ensure that the paddles do not engage the brake beam wear liners.

7. The railway car truck of claim 1, wherein an exterior surface of each paddle cap engages the corresponding brake beam wear liner to guide movement of the paddles.

8. The railway car truck of claim 1, wherein the paddle caps are held on the paddles by an interference fit.

9. The railway car truck of claim 1, wherein the paddle caps take up a portion of a gap between the paddle and the brake beam wear liner.

10. A brake beam assembly for a railway car truck, the brake beam assembly comprising:

a brake beam configured to be mounted between opposed side frames of the railway car truck, the brake beam having opposite right hand and left hand ends;

a strut extending from the brake beam;

brake heads coupled to the brake beam proximate to the right hand and left hand ends thereof, each brake head holding a brake shoe configured to engage a wheel of the railway car truck;

paddles exterior of the brake heads, the paddles having distal ends configured to be received in corresponding guide brackets of the side frames to guide movement of the brake beam with respect to the side frames; and

paddle caps covering the distal ends of the paddles, the paddle caps being configured to be received in brake beam wear liners comprised of a nylon or a high molecular weight polyethylene material in corresponding side frames of the railway car truck, the paddle caps having a lower coefficient of friction than the paddles, wherein the paddle caps are manufactured from a nylon or a high molecular weight polyethylene material to reduce wear on the brake beam wear liner.

11. The brake beam assembly of claim 10, wherein each paddle cap has a cavity that receives a distal end of the corresponding paddle.

12. The brake beam assembly of claim 10, wherein the paddle caps surround the paddles to ensure that the paddles do not engage the brake beam wear liners.

13. The brake beam assembly of claim 10, wherein each paddle cap includes a top, a bottom, and a distal end, the top, bottom and distal ends being configured to face corresponding surfaces of the brake beam wear liner.

14. The brake beam assembly of claim 10, wherein each paddle cap includes rounded edges and corners facing the brake beam wear liner.

15. The brake beam assembly of claim 10, wherein an exterior surface of each paddle cap is configured to engage a corresponding brake beam wear liner to guide movement of the paddles.

16. The brake beam assembly of claim 10, wherein the paddle caps are held on the paddles by an interference fit.

#1416881

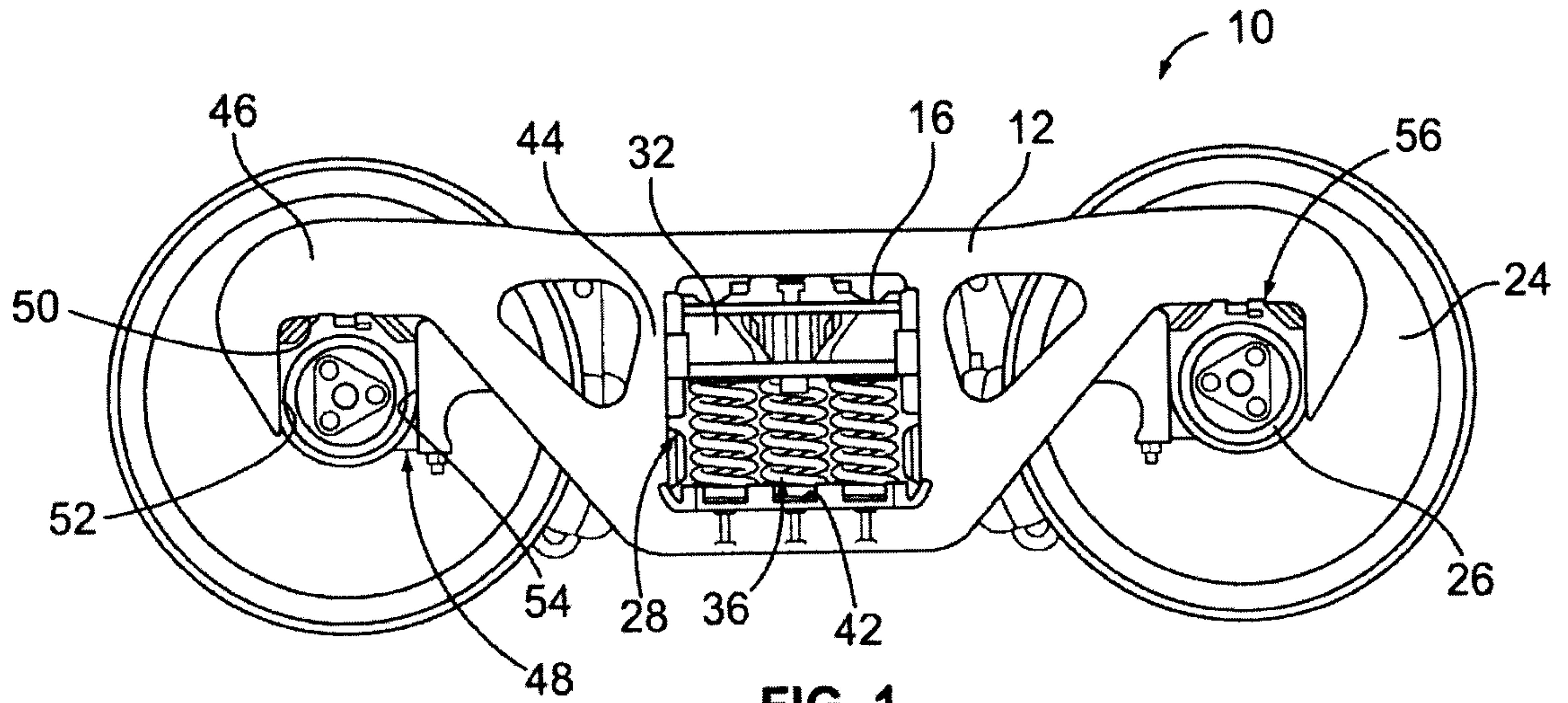

FIG. 1

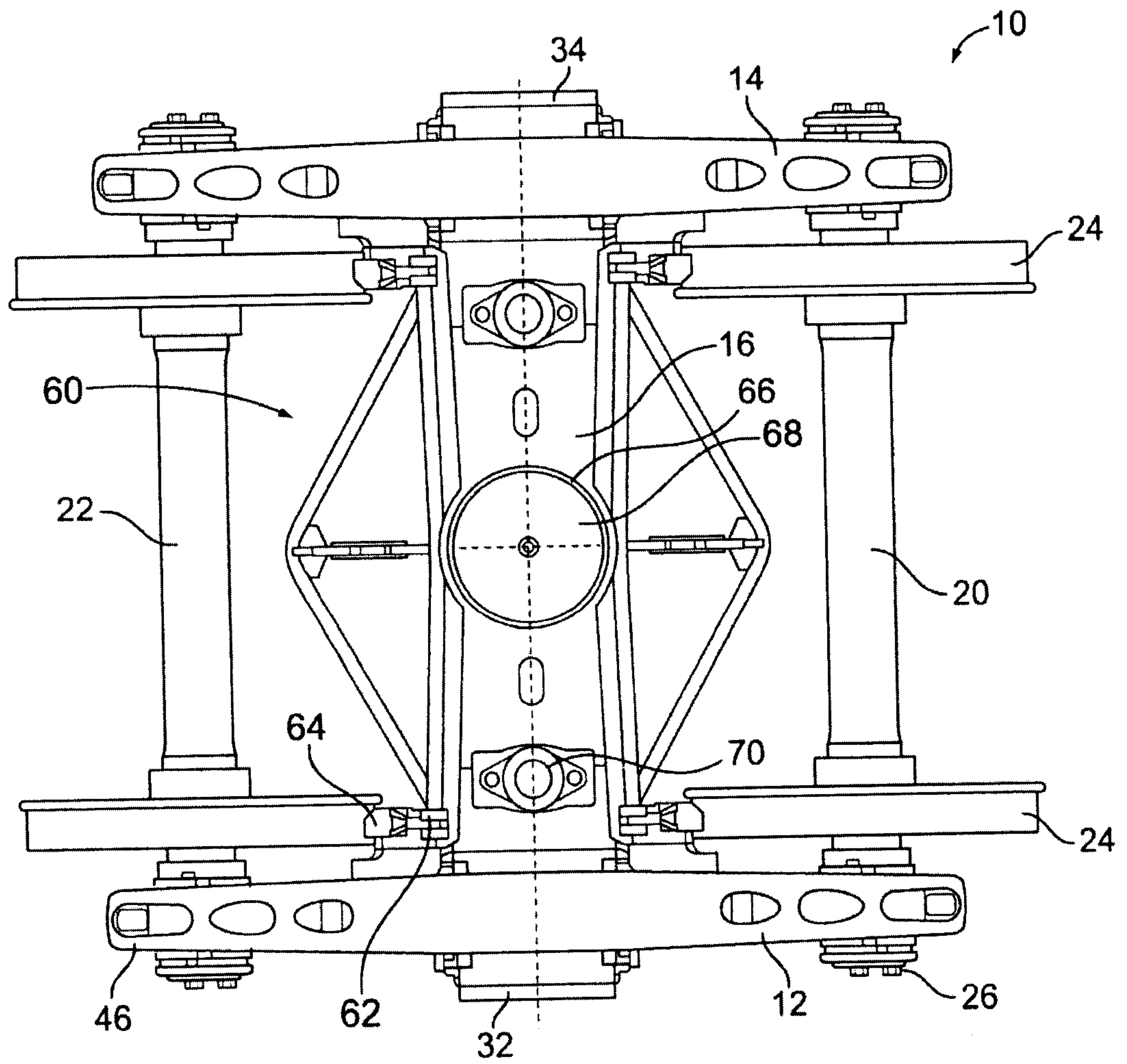

FIG. 2

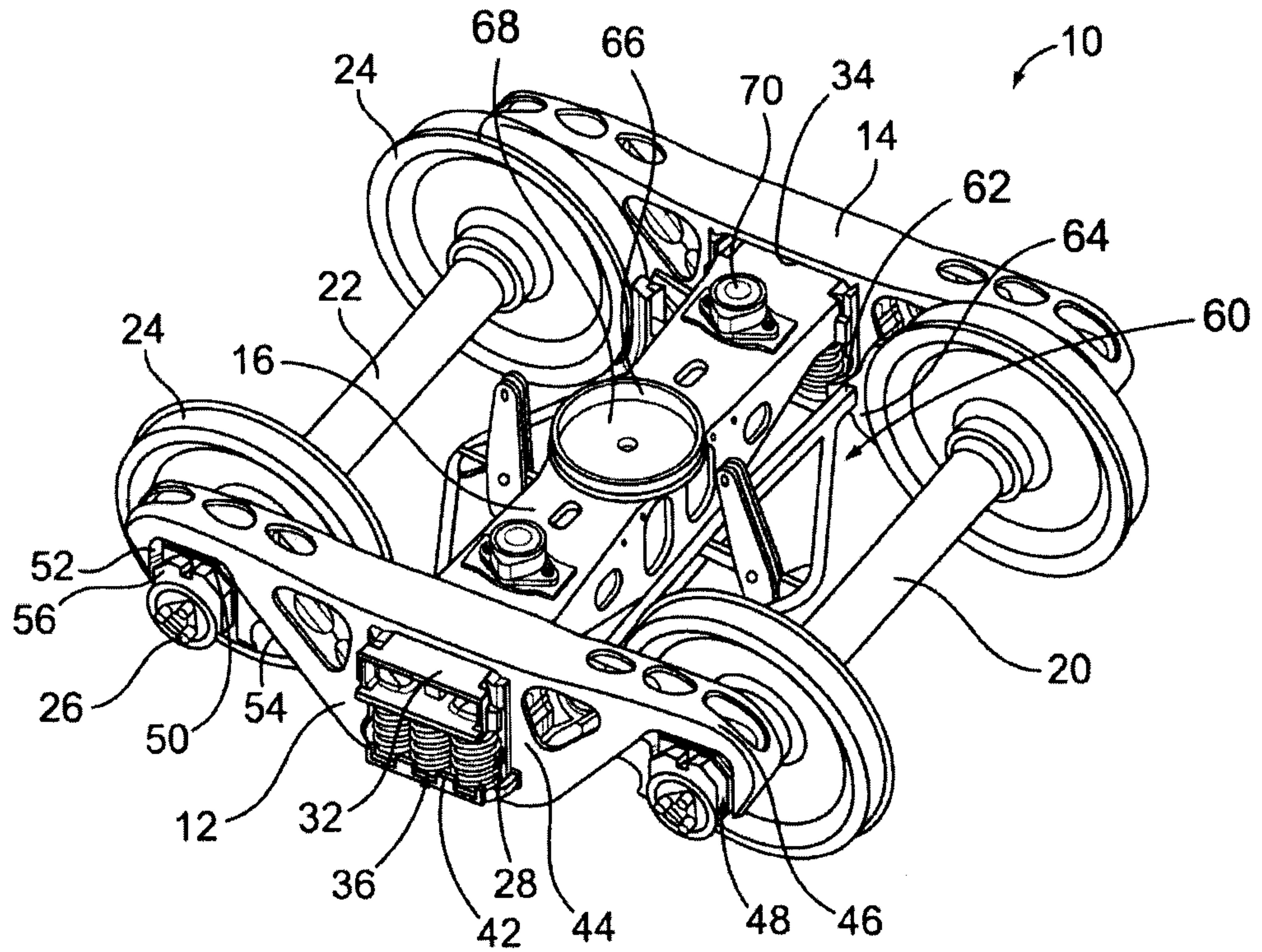

FIG. 3

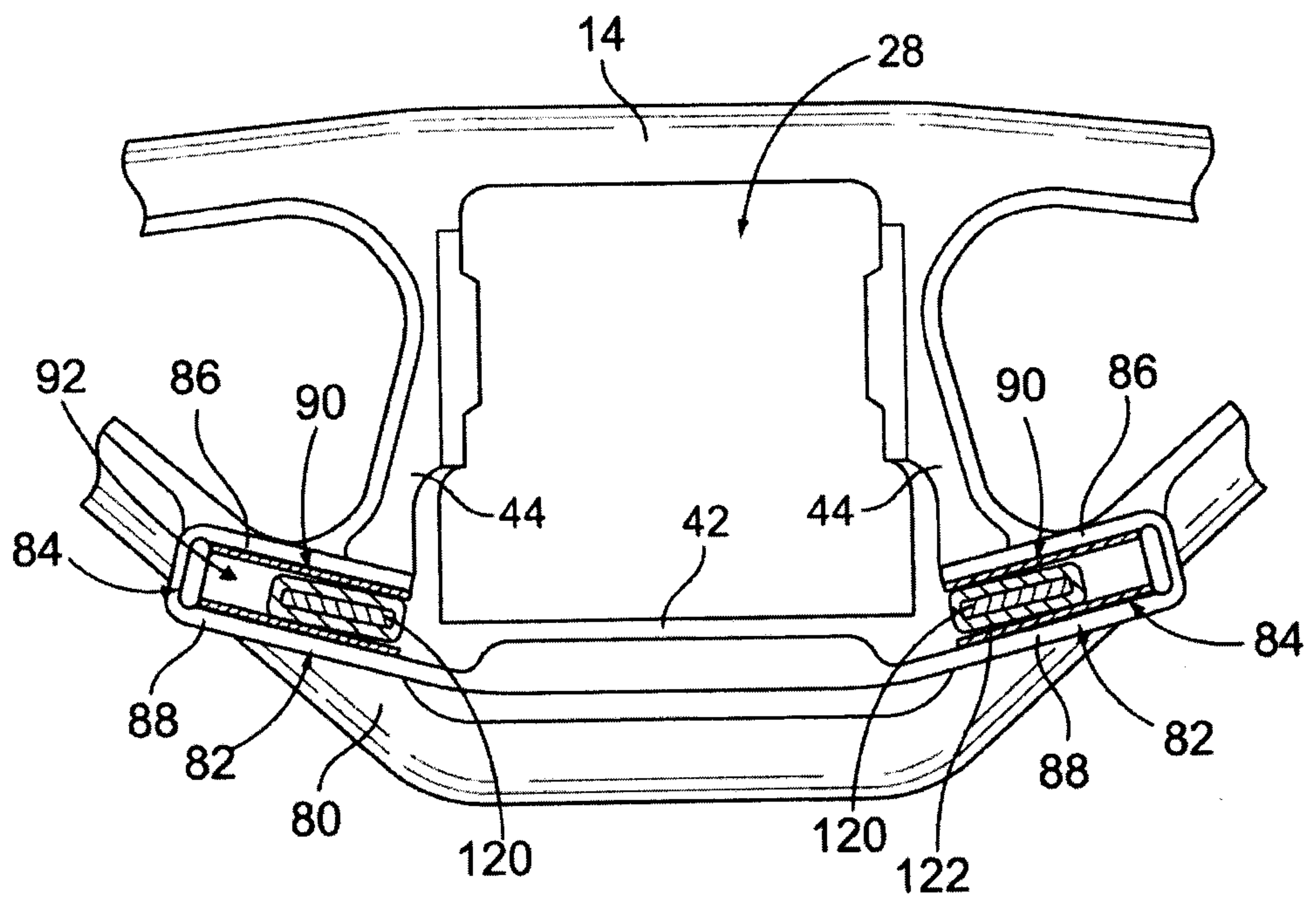

FIG. 4

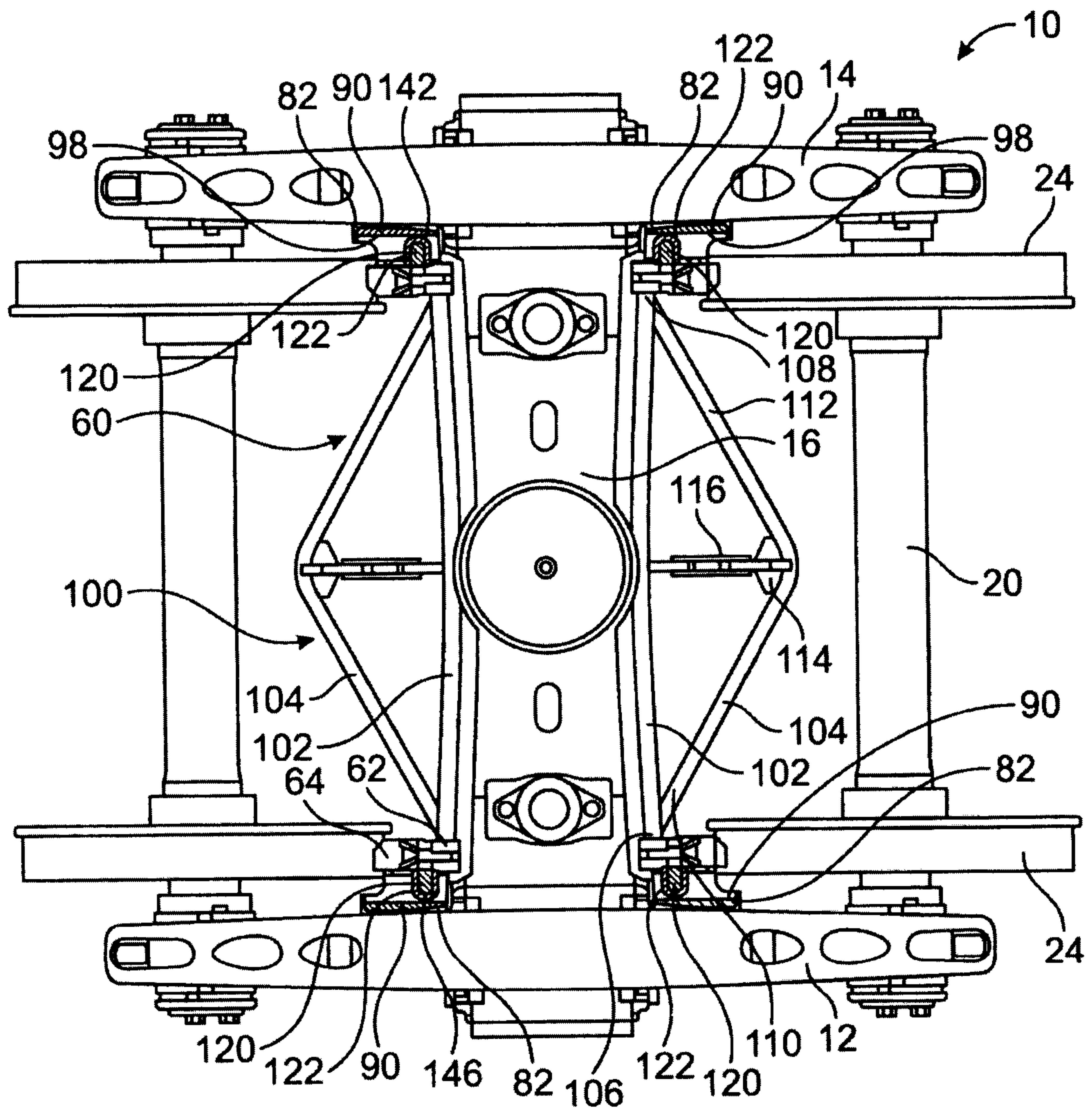

FIG. 5

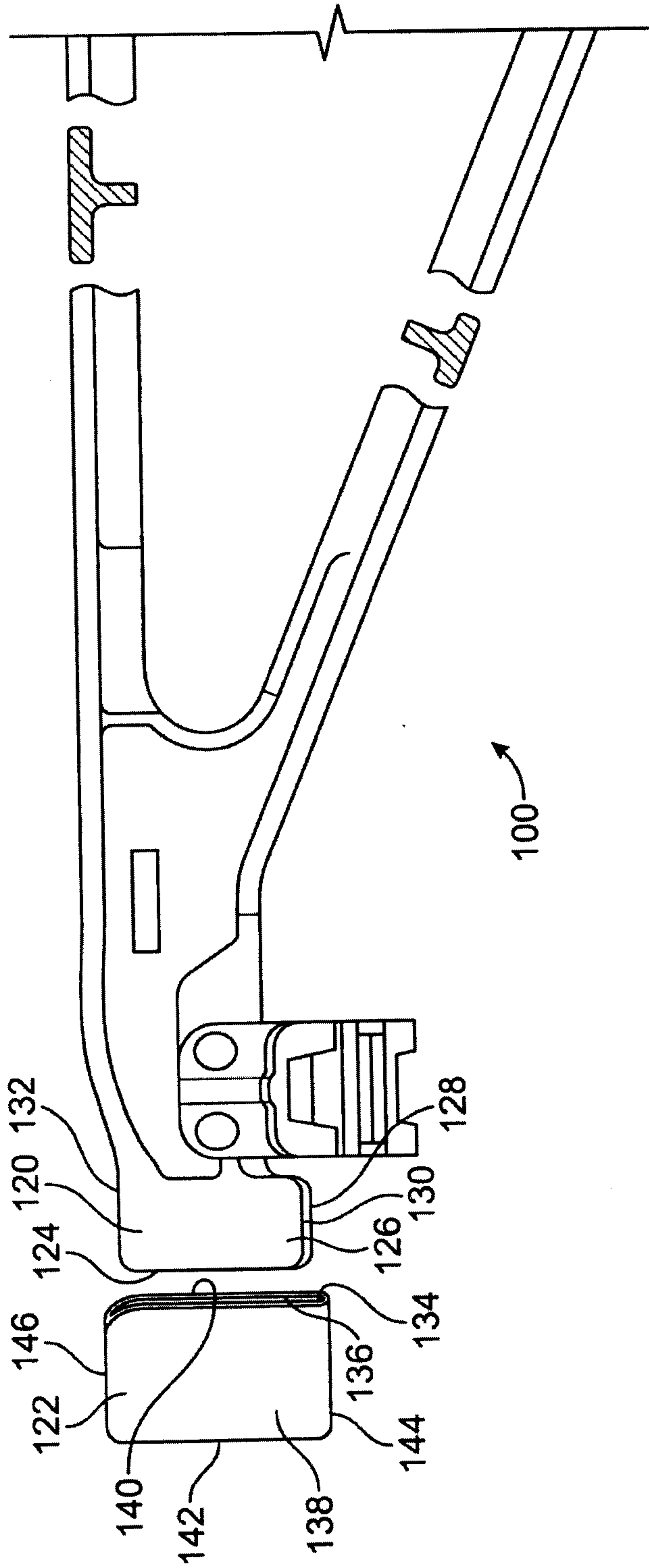

FIG. 6

