



- (51) International Patent Classification:
A61B 17/32 (2006.01) A61B 17/3207 (2006.01)
A61B 17/16 (2006.01)
- (21) International Application Number:
PCT/US2013/025414
- (22) International Filing Date:
8 February 2013 (08.02.2013)
- (25) Filing Language: English
- (26) Publication Language: English
- (30) Priority Data:
61/596,590 8 February 2012 (08.02.2012) US
61/655,391 4 June 2012 (04.06.2012) US
61/670,540 11 July 2012 (11.07.2012) US
61/722,940 6 November 2012 (06.11.2012) US
- (71) Applicants: **IMDS CORPORATION** [US/US]; 124 South 600 West, Logan, UT 84321 (US). **SCHUELER, Michael** [CH/CH]; Mellgentenstrasse 4, CH-8280 Kreuzlingen (CH).
- (72) Inventor; and
- (71) Applicant : **KATHER, Jens** [CH/CH]; Im Gatter 6, CH-8121 Benglen (CH).

- (72) Inventors: **JUSTIN, Daniel, F.**; 8501 Amber Oak Dr., Orlando, FL 32817 (US). **BUTTERS, Joshua, A.**; 1226 North Benson Lane, Chandler, AZ 85224 (US). **ARNETT, Jeffery, D.**; 2642 E. Majestic Eagle, Gilbert, AZ 85297 (US). **SLATER, Nicholas**; 352 West Aster Drive, Chandler, AZ 85248 (US). **HUSHKA, Dylan, M.**; 1138 S. Agnes Ln., Gilbert, AZ 85296 (US). **SCOTT, Melissa, D.**; 81 Main St., Flanders, NJ 07836 (US). **COALE, Bradford, J.**; 81 Main St., Flanders, NJ 07836 (US).
- (74) Agent: **HAYS, G., Jo**; IMDS Corporation, 124 South 600 West, Logan, UT 84321 (US).
- (81) Designated States (*unless otherwise indicated, for every kind of national protection available*): AE, AG, AL, AM, AO, AT, AU, AZ, BA, BB, BG, BH, BN, BR, BW, BY, BZ, CA, CH, CL, CN, CO, CR, CU, CZ, DE, DK, DM, DO, DZ, EC, EE, EG, ES, FI, GB, GD, GE, GH, GM, GT, HN, HR, HU, ID, IL, IN, IS, JP, KE, KG, KM, KN, KP, KR, KZ, LA, LC, LK, LR, LS, LT, LU, LY, MA, MD, ME, MG, MK, MN, MW, MX, MY, MZ, NA, NG, NI, NO, NZ, OM, PA, PE, PG, PH, PL, PT, QA, RO, RS, RU, RW, SC, SD, SE, SG, SK, SL, SM, ST, SV, SY, TH, TJ, TM, TN, TR, TT, TZ, UA, UG, US, UZ, VC, VN, ZA, ZM, ZW.

[Continued on next page]

(54) Title: CURVED ARTHROSCOPIC BURR

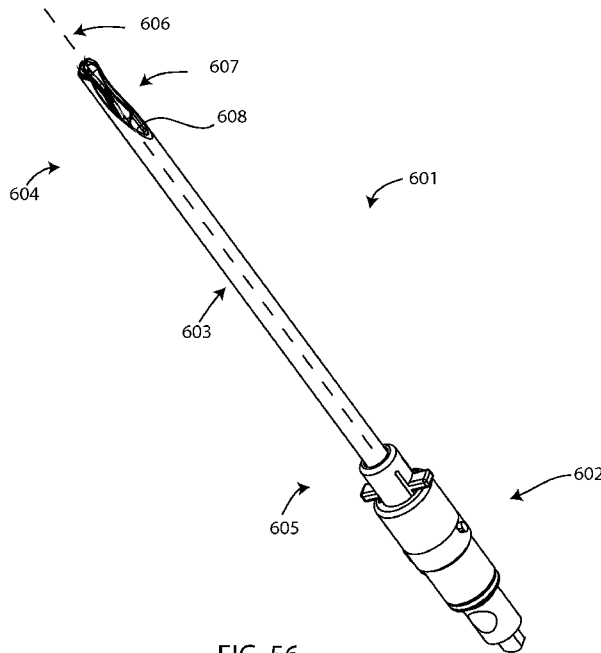

FIG. 56

(57) Abstract: A tissue resection device may include an hourglass shaped burr to resect tissue according to the shape and curvature of the hourglass shaped burr. The tissue resection device may also include a depth stop window and a movable protective guard to control the amount of cutting.





(84) Designated States (*unless otherwise indicated, for every kind of regional protection available*): ARIPO (BW, GH, GM, KE, LR, LS, MW, MZ, NA, RW, SD, SL, SZ, TZ, UG, ZM, ZW), Eurasian (AM, AZ, BY, KG, KZ, RU, TJ, TM), European (AL, AT, BE, BG, CH, CY, CZ, DE, DK, EE, ES, FI, FR, GB, GR, HR, HU, IE, IS, IT, LT, LU, LV, MC, MK, MT, NL, NO, PL, PT, RO, RS, SE, SI, SK,

SM, TR), OAPI (BF, BJ, CF, CG, CI, CM, GA, GN, GQ, GW, ML, MR, NE, SN, TD, TG).

Published:

— *with international search report (Art. 21(3))*

CURVED ARTHROSCOPIC BURR

BACKGROUND

[0001] The present disclosure relates to surgical instruments, such as arthroscopic surgical instruments. The principles herein are applicable in tissue removal applications, whether arthroscopic, laparoscopic, endoscopic, or open, including but not limited to: foot, ankle, knee, hip, pelvis, spine, ribs, shoulder, elbow, wrist, hand, craniomaxillofacial, etc.

[0002] Straight or spherical rigid cutting instruments are not well suited to creating a smooth anatomic radius of curvature with minimal manipulation. Therefore, with these tools, it is up to the surgeon to sculpt a three-dimensional (3D) anatomic surface by manipulating the cutter over the treated surface, without unintentionally removing too much tissue. This requires great skill, practice, patience, and time.

[0003] It is desirable to provide a more efficient means of tissue removal, including removal of sclerotic bone, in order to reduce operating time. The disclosed examples are capable of removing tissue on multiple surfaces at once, creating a smooth uniform surface with minimal manipulation of the instrument. The instruments described herein may automatically re-establish a proper anatomic profile to the treated surface by matching the natural anatomic profile of the tissue. The instruments described herein are capable of producing 3D shaping with simple two-dimensional (2D) manipulation of the instruments. The instruments and methods described herein may significantly reduce operating time and produce more uniform results.

[0004] The tissue resection devices or burr tools disclosed herein are capable of matching the natural anatomic curvature of a tissue. In one example, the tissue resection device includes an outer housing, a drive member, a central flexible member, rotary cutting elements, and bearing elements. The outer housing and/or cutting elements may be curved to approximately match the geometry of a tissue. The outer housing or sheath may have at least one cutout, opening, or window through which the cutting elements, inserts, or burrs are exposed to effect the tissue resection. The cutout or window in the outer housing may be sized, shaped, and/or adjusted to vary the amount of burr exposure through the window to vary the amount/depth of tissue that is removed in a single pass of the instrument. In this manner, the window may act like a depth stop to provide extra control and precision over tissue removal and prevent unintended tissue removal. In some examples, the depth stop may allow a substantially uniform depth cut along the curved burr portion of the resection device. For example, the window in the outer sheath may be sized to allow the burrs to project about 1 mm from the window. In other examples, the burrs may project more or less than 1 mm. In yet other examples, the user may selectively adjust how much the burrs project from the window. In this manner, the user may control the depth of the tissue cut in a single pass and prevent the resection device from cutting away too much tissue.

[0005] In some examples disclosed herein, the cutting inserts, elements, or burrs are circular members that include a number of cutting arms with sharp edges that are designed to cut tissue, such as bone. The number of cutting arms may be varied to remove more or less tissue in a single revolution of the burr. In one example, the cutting insert has three arms. The cutting elements may also include a central hole through which a central flexible member may pass. The burrs may be slid over the central flexible member to create a flexible cutting assembly. In this example, the burrs may act like beads on a necklace moving and flexing with the central member. The burr elements may also possess mating teeth that interface with adjacent burrs to form a stack. The mating teeth allow torque to be transmitted through the series or stack of mating burrs. In some examples, the central flexible member may, or may not, be required to provide torque to the system as the burrs themselves may transmit the torque required for cutting.

[0006] In some applications of the disclosed technology, the efficacy of the tissue removal procedure may be evaluated by removing all instruments and articulating the affected joint post-resection to ensure impingement-free motion. Direct visualization, medical imaging, palpation, or other assessment means may also be used to evaluate the effectiveness of the tissue removal. Operative time may be further reduced by using measurement devices that serve as anatomic templates for the treated region. The measurement devices disclosed herein provide an anatomic basis for evaluation of tissue removal, without the need to articulate the joint and directly test range of motion, or resort to medical imaging, or the like.

[0007] In an example, a tissue resection device includes a housing extending between proximal and distal ends, a portion of the housing extending along an arcuate path forming an arcuate housing portion, the housing including a housing window; a drive shaft; and a plurality of cutting inserts coupled together in a sequence extending along the arcuate path and partially received in the housing window, the proximal most cutting insert coupled to the drive shaft, wherein each cutting insert includes at least one cutting edge and wherein each cutting insert is non-cylindrical.

[0008] In another example, a tissue resection device includes a housing extending between proximal and distal ends, a portion of the housing extending along an arcuate path forming an arcuate housing portion, the housing including a housing window; a drive shaft; and a plurality of cutting inserts coupled together in a sequence extending along the arcuate path and partially received in the housing window, the proximal most cutting insert coupled to the drive shaft, wherein each cutting insert includes at least one cutting edge and wherein each cutting insert is differently shaped than each of the other cutting inserts.

[0009] In yet another example, a tissue resection device includes a housing extending between proximal and distal ends, a portion of the housing extending along an arcuate path forming an arcuate housing portion, the housing including a housing window; a drive shaft; and a plurality of cutting inserts coupled together in a sequence extending along the arcuate path and partially

received in the housing window, the proximal most cutting insert coupled to the drive shaft, wherein each cutting insert includes at least one cutting edge, and wherein the cutting edges form a cutting profile which includes at least one straight section and at least one curved section.

BRIEF DESCRIPTION OF THE DRAWINGS

[0010] While examples of the present technology have been shown and described in detail below, it will be clear to the person skilled in the art that variations, changes and modifications may be made without departing from its scope. As such, that which is set forth in the following description and accompanying drawings is offered by way of illustration only and not as a limitation. The actual scope of the invention is intended to be defined by the following claims, along with the full range of equivalents to which such claims are entitled.

[0011] In the following Detailed Description, various features are grouped together in several examples for the purpose of streamlining the disclosure. This method of disclosure is not to be interpreted as reflecting an intention that examples of the technology require more features than are expressly recited in each claim. Rather, as the following claims reflect, inventive subject matter lies in less than all features of a single disclosed example. Thus, the following claims are hereby incorporated into the Detailed Description, with each claim standing on its own as a separate example.

[0012] Identical reference numerals do not necessarily indicate an identical structure. Rather, the same reference numeral may be used to indicate a similar feature or a feature with similar functionality. Not every feature of each example is labeled in every figure in which that example appears, in order to keep the figures clear. Similar reference numbers (e.g., those that are identical except for the first numeral) are used to indicate similar features in different examples.

[0013] FIG. 1 is a side view of a tissue resection device;

[0014] FIG. 2A is an isometric detail view of a portion of the tissue resection device of FIG. 1; and FIG. 2B is a side detail view of the portion of the tissue resection device of FIG. 1 shown in FIG. 2A, with an outer sheath removed;

[0015] FIG. 3 is an isometric view of a cutting insert of the tissue resection device of FIG. 1;

[0016] FIG. 4 is an isometric view of several cutting inserts in a stacked arrangement;

[0017] FIG. 5 is a side view of a measurement device;

[0018] FIG. 6 is a side detail view of a portion of the measurement device of FIG. 5

[0019] FIG. 7 is a side detail view of a portion of another measurement device;

[0020] FIG. 8 is an isometric view of the tissue resection device of FIG. 1 in use against a femoral neck;

[0021] FIG. 9 is an isometric detail view of the measurement device of FIG. 5 in use against a femoral neck and head;

- [0022] FIG. 10 is a side detail view of the measurement device of FIG. 7 in use against a tissue surface;
- [0023] FIG. 11A is a side view of another tissue resection device; FIG. 11B is a detail view of a portion of the tissue resection device of FIG. 11A in a deployed condition; and FIG. 11C is another detail view of a portion of the tissue resection device of FIG. 11A in a retracted condition;
- [0024] FIG. 12 is a side detail view of a portion of yet another measurement device;
- [0025] FIG. 13 is a side detail view of a portion of yet another measurement device;
- [0026] FIG. 14 is an isometric detail view of a portion of the tissue resection device of FIG. 11A and a guide tool in use against a femoral neck and head;
- [0027] FIG. 15 is a side detail view of a portion of the measurement device of FIG. 12 in use against a femoral neck and head;
- [0028] FIG. 16 is a side detail view of a portion of yet another tissue resection device;
- [0029] FIG. 17 is a side detail view of a portion of yet another tissue resection device;
- [0030] FIG. 18 is an isometric view of the tissue resection device of FIG. 1 and a stabilization arm;
- [0031] FIG. 19 is a side view of an arcuate portion of yet another tissue resection device with an outer sheath and some of the cutting inserts removed;
- [0032] FIG. 20A is a cross-sectional view of a distal end of yet another tissue resection device; FIG. 20B is a side view of a cannulated flexible member of the tissue resection device of FIG. 20A; FIG. 20C is a perspective view of a cutting insert of the tissue resection device of FIG. 20A engaged with the flexible member of FIG. 20B; and FIG. 20D is a side view of the cutting insert of FIG. 20C;
- [0033] FIG. 21 is a perspective view of the cutting insert of FIG. 20C;
- [0034] FIG. 22 is a perspective view of a distal end of yet another tissue resection device;
- [0035] FIG. 23 is a perspective view of the tissue resection device of FIG. 22 with an end cover removed;
- [0036] FIG. 24 is a perspective view of the distal end of yet another tissue resection device with an outer sheath removed;
- [0037] FIG. 25 is a perspective view of the tissue resection device of FIG. 24 with an end cover removed;
- [0038] FIG. 26 is a perspective view of the distal end of yet another tissue resection device with an outer sheath and an end cover removed;
- [0039] FIG. 27A is a side cross-sectional view of the tissue resection device of FIG. 26; FIG. 27B is a perspective view of a cutting insert of the tissue resection device of FIG. 26; FIG. 27C is a perspective view of the cutting insert of FIG. 27B; and FIG. 27D is a table of exemplary connection shapes which may be used with the cutting inserts of the present disclosure;

[0040] FIG. 28 is a side view of yet another tissue resection device with the cutting inserts exposed on a convex portion of the distal end of the tip;

[0041] FIG. 29 is a side view of yet another tissue resection device with the cutting inserts exposed on convex and concave portions of the distal end of the tip;

[0042] FIG. 30A is a side view of yet another tissue resection device; FIG. 30B is a side view of yet another tissue resection device; FIG. 30C is a side view of yet another tissue resection device; and FIG. 30D is a side view of yet another tissue resection device;

[0043] FIG. 31A is an isometric view of yet another tissue resection device; and FIG. 31B is a side view of the tissue resection device of FIG. 31A;

[0044] FIG. 32A is a top view of the tissue resection device of FIG. 31A; and FIG. 32B is a bottom view of the tissue resection device of FIG. 31A;

[0045] FIG. 33 is an isometric exploded view of the tissue resection device of FIG. 31A;

[0046] FIG. 34 is a side cross-sectional view of the tissue resection device of FIG. 31A taken along section line 4-4 in FIG. 32A;

[0047] FIG. 35A is a top view of a housing of the tissue resection device of FIG. 31A; FIG. 35B is a bottom view of the housing of FIG. 35A; FIG. 35C is a side view of the housing of FIG. 35A; FIG. 35D is a side cross-sectional view of the housing of FIG. 35A taken along section line 5-5 in FIG. 35A;

[0048] FIG. 36A is an isometric view of a cutting insert of the tissue resection device of FIG. 31A; FIG. 36B is a side view of the cutting insert of FIG. 36A; FIG. 36C is an end view of the cutting insert of FIG. 36A;

[0049] FIG. 37A is an isometric view of another cutting insert of the tissue resection device of FIG. 31A; FIG. 37B is a side view of the cutting insert of FIG. 37A; FIG. 37C is a side cross-sectional view of the cutting insert of FIG. 37A; and FIG. 37D is an end view of the cutting insert of FIG. 37A;

[0050] FIG. 38 is a side view of a cutting assembly of cutting inserts of the tissue resection device of FIG. 31A;

[0051] FIG. 39 is a line depicting a profile cut by the cutting assembly of the tissue resection device of FIG. 31A;

[0052] FIG. 40 is a side view of cutting inserts of yet another tissue resection device;

[0053] FIG. 41 is a side view of cutting inserts of yet another tissue resection device;

[0054] FIG. 42 is a side view of cutting inserts of yet another tissue resection device;

[0055] FIG. 43 is a side view of cutting inserts of yet another tissue resection device;

[0056] FIG. 44 is a side view of cutting inserts, bushings and drive shaft of yet another tissue resection device;

- [0057] FIG. 45 is a side view of cutting inserts, bushings and drive shaft of yet another tissue resection device;
- [0058] FIGS. 46-55 are lines depicting profiles which may be cut by other tissue resection devices;
- [0059] FIG. 56 is an isometric view of a tissue resection device;
- [0060] FIG. 57 is a side view of the tissue resection device of FIG. 56;
- [0061] FIG. 58 is a bottom view of the tissue resection device of FIG. 56;
- [0062] FIG. 59 is an isometric view of the tissue resection device of FIG. 56 with a hollow member removed;
- [0063] FIG. 60 is an isometric view of another tissue resection device which incorporates an outer sheath with a protective hood;
- [0064] FIG. 61 is a side view of the tissue resection device of FIG. 60 with the protective hood positioned in a first position;
- [0065] FIG. 62 is a side view of the tissue resection device of FIG. 60 with the protective hood positioned in a second position;
- [0066] FIG. 63 is a close-up side view of the tissue resection device of FIG. 61 with the protective hood in the first position; and
- [0067] FIG. 64 is a close-up side view of this tissue resection device of FIG. 62 with the protective hood in the second position.

DETAILED DESCRIPTION

[0068] Standard medical planes of reference and descriptive terminology are employed in this specification. A sagittal plane divides a body into right and left portions. A mid-sagittal plane divides the body into bilaterally symmetric right and left halves. A coronal plane divides a body into anterior and posterior portions. A transverse plane divides a body into superior and inferior portions. Anterior means toward the front of the body. Posterior means toward the back of the body. Superior means toward the head. Inferior means toward the feet. Medial means toward the midline of the body. Lateral means away from the midline of the body. Axial means toward a central axis of the body. Abaxial means away from a central axis of the body. Ipsilateral means on the same side of the body. Contralateral means on the opposite side of the body. These descriptive terms may be applied to an animate or inanimate body.

[0069] Referring to FIG. 1, a tissue resection device 10 may include a proximal drive hub 20, an outer tube or sheath 30, and distal cutting inserts 40. As shown in FIG. 2A, the cutting inserts 40 are exposed through a window 32 in the sheath 30 yet retained within the diameter of the outer sheath 30. The cutting inserts 40 may rotate within the outer sheath 30. FIG. 2B illustrates the cutting inserts 40 interlocking together and adapting to a curvature.

[0070] In some examples, the tissue resection device 10 may also include an optional stabilization arm 50 that may attach near the distal end of the instrument to provide greater force and control while manipulating the instrument. FIG. 18 illustrates one example of a tissue resection device 10 that includes an optional stabilization arm 50. The stabilization arm 50 may couple to the sheath 30 between the hub 20 and the distal end of the resection device 10. For example, the stabilization arm may couple to the sheath 30 near the cutting inserts 40. The stabilization arm may extend oblique, transverse, or perpendicular to the sheath 30. When coupled to the sheath 30, the arm may lie in the same plane as the arc of curvature of the distal cutting portion, or at another angle. The stabilization arm 50 may be selectively detached or attached to the tissue resection device 10, or may be an integrally formed member of the tissue resection device 10.

[0071] As shown in FIG. 3, the cutting insert 40 may have a plurality of arms 44 and cutting edges 41 radially arranged about a central aperture 46. The cutting inserts 40 may mesh together, interlock, or overlap each other, by fitting into the interlock recesses 43 of adjacent cutting inserts 40 as demonstrated in FIG. 4. In this example, each cutting insert 40 may be driven to rotate through their respective mating surfaces 42 by adjacent cutting inserts 40. Thus, in this example, the cutting inserts 40 are constructed such that each insert drives the next one. The illustrated interconnection between adjacent cutting inserts 40 is an example of a torque coupling which transmits torque between two adjacent cutting inserts which are set at an angle to each other.

[0072] In other examples, torque may be transmitted by other means to each cutting insert 40, such as by a central flexible member, drive shaft, or cable. The flexible member may be a stranded flexible metallic cable, flexible wire, a flexible laser-cut puzzle piece shaft, spring, flexible polymeric shaft/wire, or the like.

[0073] FIG. 19 illustrates a portion of the distal end of another tissue resection device utilizing a flexible cable 190 to drive cutting inserts 40. Some of the cutting inserts 40 have been removed to better visualize how the flexible cable 190 may interact with the cutting inserts 40. In some examples, the cutting inserts 40 may be welded to the flexible cable 190 and driven by the cable 190 directly. In other examples, the flexible cable may be shaped to interact with complimentary shapes formed in each cutting insert 40 such that the flexible cable 190 drives each cutting insert directly. For example, the cable may have protrusions or depressions formed therein and shaped to act with complimentary shaped protrusions or depressions formed in each cutting insert 40. In yet other examples, there may be a mix of some cutting inserts 40 that are driven by adjacent cutting inserts 40 and other cutting inserts 40 that are driven directly by the central flexible drive shaft or cable 190, in any proportion, ratio, or number.

[0074] FIGS. 20A-20D illustrate one example of a tissue removal device 301 with a flexible member 300 with a key 302 shaped to interact with a slot 306 formed in a suitable cutting insert 304. The flexible member 300 imparts torque to the cutting insert 304 through the key 302 engaged

in the slot 306 of the cutting insert. The cutting insert 304 may also impart torque to adjacent cutting inserts 304 through projections 303 interacting with recesses 305 such that adjacent cutting inserts 304 do not need a slot 306, similar to the cutting insert shown in FIG. 21.

[0075] Referring to FIG. 5, a measurement device 60 may include a shaft 64 and a tip 66. The configuration in FIG. 6 illustrates a flexible measuring device that is made to replicate the desired anatomic curvature of the treatment location, such as a femoral head/neck junction. This anatomic curvature may be built into the measurement device 60 to provide a template for the user to allow the user to visually determine if the proper amount of tissue has been resected. The instrument may have an additional feature 61 to conform to a region adjacent to the treatment location, in this example the femoral head, but is not required, as shown in the right hand image of FIG. 6. The tip 66 may include one or more flexibility zones 68, here illustrated as wavy portions.

[0076] FIG. 7 depicts a tip 76 and a portion of a shaft 74 of another measurement device 70. In this example, a plurality of spring-biased indicators 71 are used to detect irregularities in the desired anatomic curvature. The ideal geometry may be indicated by the indicators being flat along the top of the instrument when the bottoms of the indicators rest on a surface. Any deviation from this flat arrangement indicates a region of tissue that requires resection in order to produce the desired curvature to the treatment region, for example to provide impingement-free motion of a joint. This measurement device 70 may allow the user to pinpoint the exact location and size of sclerotic lesions. The tip 76 may include an optional extension 73 to conform to a region adjacent to the treatment location, in this example a femoral head. The tip 76 may include one or more flexibility zones 78.

[0077] In one example, the tissue resection device 10 depicted in FIGS. 1 and 8 may have geometry specific to femoroacetabular impingement surgery to alleviate a cam impingement from an approach perpendicular to the femoral neck. Cam impingement is a type of femoroacetabular impingement in which protruding tissue on the femoral neck and/or head impinges the acetabular rim. A perpendicular approach may allow for access to a larger section of the femoral neck, which may improve the ability to sculpt the anatomy. This curved tissue removal technology may be applied to a multitude of tissue removal applications and is not limited to arthroscopic hip surgery. The tissue resection device 10 may be introduced through an access portal and directed generally perpendicular to the femoral neck, until the cutting inserts 40 engage the femoral neck, head/neck junction, or head as shown in FIG. 8. The device 10 may be swept along the femoral neck to remove asperities and restore the neck to a smooth, anatomically correct curve.

[0078] In other examples, the tissue resection devices disclosed herein may be configured to enter through different portals that are not perpendicular to the femoral neck, such as the mid-anterior portal. In some examples, the tissue resection devices may include a pivoting section (not shown) between the arcuate portion at the distal end of the tissue resection device and the hub at the

proximal end of the tissue resection device. The pivoting section may be positioned at any point along the outer sheath 30 or it may be part of the arcuate portion or the hub. In other examples, the outer sheath may be permanently angled at any point and at any angle along its length. In still further examples, the outer sheath 30 may have multiple angles along its length, any of which may be permanently formed in the outer sheath 30, or achieved by including one or more pivoting sections along the length of the outer sheath. In yet further examples, the outer sheath may be permanently curved at any point and at any radius of curvature along its length. In still other examples, the outer sheath 30 may be flexible along its entire length, or at one or more points or portions along its length to allow the surgeon to bend the outer sheath 30 to any desired shape or angle during surgery.

[0079] FIG. 9 shows the flexible measurement device 60 of FIG. 6 interacting with a femoral head/neck junction 63 with the rigid section 62 not aligning flat to the anatomy. This mal-alignment may indicate that tissue should be resected in this region for impingement-free motion of the hip joint. FIG. 10 depicts a similar arrangement for the device 70 of FIG. 7, and illustrates the movement of the indicators 71 where they interact with the tissue to be resected 72. The indicators have moved out of line to indicate the zone of tissue resection.

[0080] Concerning materials, in the tissue resection device 10, the cutting surfaces and housing may both be made of a biocompatible metal, such as stainless steel. The measurement instruments 60 and 70 may be constructed of a biocompatible polymeric material, such as polypropylene. Other medical grade metals or plastics may also be used, either alone or in combination. In addition, surface treatments or additives may be included to provide beneficial effects such as anti-wear or other improved mechanical properties.

[0081] FIGS. 11A, 11B, and 11C show an expandable burr 80 for resecting tissue across a broad area. The open position (FIGS. 11A-B) allows for the cutting surfaces 81 to cover more area than the instrument initially requires in the retracted position (FIG. 11C) for delivery to the surgical site. The cutting surfaces 81 are driven to rotate by a bevel gear arrangement in a distal end of a shaft of the expandable burr 80. The cutting surfaces 81 may be roughened, textured, or fluted with straight or helical cutting flutes.

[0082] FIG. 12 shows yet another measurement device 90, which includes a bladder 91 to indicate a volumetric abnormality from the desired geometry. Volumetric changes in the bladder 91 may be read by the user by either a fluid or gas triggering a movement along a calibrated scale. The scale may be located along a shaft of the instrument. Another example of this measurement method would be a closed system with a syringe attached. When actuated, the plunger of the syringe would move per the change in volume of the bladder.

[0083] FIG. 13 illustrates yet another measurement device 100. In this example, spring deflection may be used to establish deviation from a desired geometry 101. The flexing of the

instrument to accommodate abnormal anatomy may be read on a calibrated scale. The scale may be located along a shaft of the instrument.

[0084] FIG. 14 shows the expandable burr 80 of FIGS. 11A-11C in use on a femoral neck with a fixed guide 110 acting as a cutting template for the burr 80. The use of a fixed template may also keep the user from resecting more tissue than desired. In this example, the expandable burr 80 slides along the fixed guide 110 with the cutting surfaces 81 extending bilaterally from the guide 110 to contact and cut tissue.

[0085] FIG. 15 shows the measurement device 90 of FIG. 12 in use against a femoral neck and head. One may appreciate that fluid or gas will move out of the bladder in response to pressure urging the bladder against a protruding tissue surface, thus producing an indication on a scale.

[0086] FIG. 16 shows a deployable grinder 120 which may be used to sculpt the tissue, such as bony tissue of the femoral head and neck region. This may be achieved with a plurality of rotating cutters 121. The cutters 121 may rotate in opposite directions. While two cutters are shown, more may be provided. The opposing rotations help keep the instrument easily focused on the desired region. Opposing rotation toward a midline or central axis of the grinder 120 urges debris centrally for easy removal. A depth stop (not shown) may also be included with the grinder 120 to prevent unintended tissue removal. For example, an adjustable central plunger may be provided between the cutters 121.

[0087] FIG. 17 shows a deployable grater 130 which may be inserted into the surgical space in a collapsed position. When spun, the grater may deploy cutting surfaces 131 outward to contact the tissue to be resected. A deployable cutting surface has the advantage of a minimally invasive insertion while covering a broad area once actuated.

[0088] FIGS. 20A-21 show one example of a resection device 301 having a central flexible member 308 on which cutting inserts 304 may be arranged in a stack. The central flexible member 308 in this example is hollow and has lateral holes 310 along its length. This cannulated flexible member 308 permits fluid injection or fluid suction during surgery to facilitate removal of tissue debris and keep the cutting inserts 304 from clogging up with tissue debris.

[0089] FIGS. 22-25 show examples of resection devices 312, 313 that include end-cutting elements 310 on the distal tip of the instrument to perform end cuts or resections in addition to the side cutting provided by previous examples. For example, end-cutting element 310 may allow the surgeon to resect portions of an acetabular rim to reduce "pincer-type" impingements. The curved shape of the burr may also be helpful in allowing increased visualization of a rim resection procedure. The end-cutting element 310 may be covered by a protection shield or cap 311 that may be selectively removed to perform end cutting.

[0090] FIGS. 24-27C illustrate examples of resection devices 313, 318 that include a different style of cutting insert. In these examples, cutting inserts 314 are arranged along a curved line by

connecting a series of cutting inserts 314 together. The cutting inserts 314 may have one or more propeller, helical, or fluted blades or cutting edges 315 for resecting tissue. Each cutting insert 314 may have a male 316 and female 317 mating feature at opposite ends, as may be seen in FIGS. 27B and 27C. The mating features 316, 317 are able to transmit torque between adjacent cutting inserts 314 as may be seen by the cross-section of the resection device 318 shown in FIG. 27A. Arranging the cutting inserts 314 in series creates a drivetrain capable of transmitting torque through the system. The male and female mating features may be designed to allow for misalignment in the long axis of the components, such that each cutting insert 314 may still drive adjacent cutting inserts 314 even though the rotational axes of adjacent inserts are not co-linear. This allows the burrs 314 to assume a curved path. In one example, the cutting inserts 314 are connected in series, through mating ball-hex joints 319. The ball-hex joints 319 are an example of a torque coupling which transmits torque between two adjacent cutting inserts which are set at an angle to each other. However, any suitable connection shape may be used between adjacent cutting inserts 314, including, but not limited to, the shapes illustrated in FIG. 27D.

[0091] The resection devices 313, 318 may also include bearing elements 320 that hold the cutting inserts relative to the outer housing. The bearing elements 320 may engage circular features or shafts 321 on the cutting inserts to allow the cutting inserts to rotate freely relative to the housing and maintain the axial location of the cutting inserts. The bearing elements 320 may be larger in diameter than the cutting inserts to prevent the sharp cutting surfaces of the cutting inserts from contacting the outer housing.

[0092] FIG. 28 illustrates a resection device 340 that has a window or cutout on the convex side of the curved portion of the resection device 340 that exposes the cutting inserts on the convex side of the outer housing. FIG. 29 illustrates a resection device 350 that has a window on the convex side of the curved portion of the resection device, as well as a window on the concave portion of the resection device. Other examples may include windows on the sides of the resection device (not shown) perpendicular to the example of FIG. 29. Still other examples may include staggered or intermittent windows along any portion of the resection device.

[0093] Any of the devices disclosed herein may include outer housings having one or more retractable and extendible portions (not shown) to selectively uncover, cover, or partially cover one or more windows to infinitely control the size and shape of the cutting surface allowed to resect tissue. These retractable and extendible portions may be remotely controlled by the surgeon during surgery by mechanical, or other means, such as a sliding tab located on the handle of the device (not shown).

[0094] FIGS. 30A-30D show some examples of various different shapes that the resection devices of the present disclosure may assume to produce different shaped tissue resections. There are an infinite number of curves, combinations of curves, or other shapes that the resection devices

of the present disclosure may assume without departing from the spirit or scope of the present disclosure.

[0095] Referring to FIGS. 31A-34, a tissue resection device 400 includes a drive assembly 402, housing assembly 404, and cutting assembly 406. Tissue resection device 400 may be referred to as a burr. In some examples, the drive assembly 402 may be adapted for grasping the tissue resection device and manipulating the position of the tissue resection device in any direction or orientation. For example, the drive assembly 402 may be adapted to interact with a powered hand piece (not shown) forming a handle for grasping the tissue resection device and manipulating the position of the tissue resection device in any direction or orientation. In other examples, the drive assembly 402 may include an integral handle formed therein. In the example shown, the drive assembly includes a drive shaft 410 which has an AO connector for connection to a powered hand piece. An outer shaft 412 attaches to the housing assembly 404 to prevent rotation of the housing assembly and provide guidance. In other examples, the drive assembly may be adapted to include other functions such as suction and/or irrigation.

[0096] Referring to Figures 33 and 35A-35D, the housing assembly 404 includes an outer housing 420 and a plurality of bearings, or bushings 422. The outer housing has a proximal end 414 and a distal end 416. The housing is open on at least one side to form a cutting window 417 between the proximal and distal ends. In the example shown, the bushings are fitted into gaps 424 in the outer housing 420; they may be press-fit or snap fitted into the gaps. In other examples, the bushings may be welded to the housing, or may be formed integrally with the housing. Each bushing includes an opening 423 for receiving and guiding a cutting insert 430. The outer housing 420 may also include a plurality of fenestrations 426 through which the cutting assembly 406 may be viewed. The fenestrations 426 also decrease the weight of the device 400 and may allow for easier cleaning of the device 400. The fenestrations 426 may also serve as suction portals. The outer housing 420 has a curved shape including an arcuate portion 419 which creates a desired cutting profile; other examples may include other shapes to create other cutting profiles.

[0097] The cutting assembly 406 includes a plurality of cutting inserts 430 arranged in a sequence. Each cutting insert 430 is coupled to the next insert 430 in the sequence, to form the cutting assembly 406. The most proximal cutting insert 430 is coupled to the drive shaft 410 so that axial rotation of the drive shaft 410 transmits torque and causes the entire cutting assembly 406 to axially rotate. The cutting inserts 430 may vary in length, width and edge profile, between inserts and within any insert.

[0098] Referring to Figures 34 and 36A-36C, each cutting insert 430 includes a cutting body 432, a hex ball 434 and a hex ball socket 436, similar to the description above for cutting insert 314. This enables each cutting insert 430 to be operably coupled to the next cutting insert in a sequence. The hex ball 434 of one insert 430 is received in the hex ball socket 436 of the adjacent insert 430

to form a ball-hex joint 440, as seen in Figure 34. A ball-hex joint is also formed between the drive shaft 410 and the proximal most cutting insert 430. In the examples shown, each of the ball hex joints provides angulation between adjacent inserts of up to $\pm 18^\circ$, although in other examples the angulation may be greater. A collar 438 separates the hex ball 434 and the cutting body 432. In other examples, each cutting insert 430 may include an axial bore extending the length of the insert to allow stringing of the inserts onto a rod or flexible member as described above. In other examples, another complementary joint such as a torx or lobed joint may be used instead of a ball-hex joint, or the shapes illustrated in FIG. 27D.

[0099] Each cutting insert 430 has at least one cutting edge 450. The cutting edges may be uniquely shaped to provide a desired cutting profile; each cutting edge 450 on an individual insert 430 may be straight, curved, spiral, or include a combination of straight, curved or spiral sections to provide the desired cutting profile. Curved sections may be convexly or concavely curved, or include a complex curve. The cutting edges 450 may be continuous, discontinuous, intersecting, or serrated. For example referring to Figures 36A-36C, a first cutting insert 460 includes cutting edges 450 with a straight section 452 and a curved section 454 separated by an angle; the resulting cutting profile will include a straight portion and a portion of an arc (as seen in Figure 39). For another example, referring to Figures 37A-37D, a second cutting insert 462 includes cutting edges 450, each of which is slightly curved. Referring to Figures 34 and 38, it may be seen that cutting insert 460, two cutting inserts 462, and another cutting insert 464 are coupled in sequence to form cutting assembly 406. The diameter of each cutting insert may vary within or between each cutting section. Each cutting insert 460, 462, 464 in this example is non-cylindrical; the diameter of the cutting insert is not constant along the length of the insert. These non-cylindrical shapes contribute to the ability of the cutting assembly 406 to more closely approximate a curved profile than would cylindrical insert shapes. However, it is appreciated that any combination of variously sized and shaped cutting inserts may be coupled in sequence to form a cutting assembly.

[00100] When operatively assembled in the outer housing 420 as in Figure 34, each cutting insert 430 is separated from the next insert by a bushing 422. The collar 438 of each insert 430 is received in the opening 423 of a bushing 422. The curvature of the outer housing 420 and the attached bushings 422 determine the final shape of the cutting assembly 406. Portions of the inserts 430 project out of the cutting window 417 of the outer housing 420. The distal end 416 of the outer housing 420 projects distally past insert 464. Referring to Figure 39, a cutting profile 500 which may be produced by a device 400 with cutting assembly 406 is shown. The cutting profile 500 is a two-dimensional representation of the shape cut by device 400 with cutting assembly 406. Cutting profile 500 includes a first straight portion 502, a first angle 504, a first curved portion 505, a second angle 507 and a second straight portion 509. The cutting profile 500 may be suitable for preparing a talus to receive a talar component of an ankle joint prosthesis. A three-dimensional

shape having an anterior-posterior profile 500 may be prepared by moving the cutting assembly 406 of device 400 medial-laterally back and forth over the bone surface as the device 400 is powered. It is appreciated that cutting inserts 460, 462 and 464 are operatively coupled together to form cutting assembly 406 which conforms to curved portion 505 without exceeding 18° between any two of the cutting inserts. It is appreciated that in other examples the degrees of angles 504, 507 may vary, as may the degree of curvature of curved portion 505. Curved portion 505 may be an arc of a circle.

[00101] In a method of use, device 400 may be used to shape a tissue surface to receive a prosthesis or other implantable member. Device 400 is operatively assembled by connecting handle assembly 402 to a powered handpiece. The distal end of device 400 is inserted into the targeted tissue area, with cutting assembly 406 directly adjacent the tissue surface to be shaped. The handpiece is powered to rotate drive shaft 410 and consequently cutting assembly 406. The device 400 is moved across the tissue surface, substantially normal to the longitudinal axis of the drive shaft 410. The device may be moved across the surface once, or back and forth, covering the same area repeatedly. When a desired amount of tissue removal is completed, the handpiece may be powered down and the device removed from the targeted tissue area. Suction may be used during or after resection to remove tissue particles. Optionally, a rongeur may be inserted into the targeted tissue area and used to remove any excess tissue and/or smooth the tissue surface.

[00102] In a method of use, device 400 may be used to prepare a talus for a talar implant. The talar implant (not shown) may have a curved attachment surface to conform closely to the anatomic geometry of the talus. By conforming to the anatomic geometry, minimal bone removal is required. Subsidence of the implant into the talus may be minimized or prevented by minimizing bone removal. However, by conforming to the anatomic geometry, this goal of minimal bone removal requires curved geometry bone preparation, which may be difficult to do. It may be difficult to get the correct curvature without leaving high or low spots on the bone. Also due to limited access between the talus and adjacent bones and tissues, it may be difficult to reach some portions of the bone to be prepared. The cutting inserts 430 on device 400 may conform to the implant profile. Thus, as the user moves the cutter two-dimensionally, medial-laterally in this example, the bone is cut to the three-dimensional implant profile. As device 400 may be powered from a single position on the anterior side, the user is able to prepare the full profile without having access issues related to reaching the inferior-posterior regions. The straight portions of cutting inserts 460, 464 allow the cutting edges to sink into the bone without the outer housing 420 making contact with the bone and preventing further depth of cut.

[00103] Referring to Figures 40-45, alternate examples of cutting assemblies are shown. Each cutting assembly includes a sequence of cutting inserts 430; the number of inserts may vary as may the shapes of the cutting edges of each insert.

[00104] Figure 40 depicts a cutting assembly 506 having five cutting inserts; four are identical cutting inserts 508 and one is a relatively larger insert 510. It is appreciated that cutting assembly 506 may be assembled with housing assembly 404 with appropriate modifications to the distribution of bushings 422, and drive assembly 402, to create a tissue cutting device which may cut the same profile as device 400.

[00105] Figure 41 depicts a cutting assembly 516 having five cutting inserts; three are identical cutting inserts 518 and one is a larger insert 520. It is appreciated that cutting assembly 516 may be assembled with housing assembly 404 with appropriate modifications to the distribution of bushings 422, and drive assembly 402, to create a tissue cutting device which may cut the same profile as device 400.

[00106] Figure 42 depicts a cutting assembly 526 having four cutting inserts; each cutting insert 528, 530, 532, 534 differs from each other in length, width and cutting edge shape. It is appreciated that cutting assembly 526 may be assembled with housing assembly 404 with appropriate modifications to the distribution of bushings 422, and drive assembly 402, to create a tissue cutting device which may cut the same profile as device 400.

[00107] Figure 43 depicts a cutting assembly 536 having five cutting inserts; four are identical insert 538, while cutting insert 540, is relatively longer and wider, and includes cutting edges with one curved section and two straight sections. It is appreciated that cutting assembly 536 may be assembled with housing assembly 404 with appropriate modifications to the distribution of bushings 422, and drive assembly 402, to create a tissue cutting device which may cut the same profile as device 400.

[00108] Figure 44 depicts a cutting assembly 546 having eight identical cutting inserts 548. It is appreciated that cutting assembly 546 may be assembled with housing assembly 404 with appropriate modifications to the distribution of bushings 422, and drive assembly 402, to create a tissue cutting device which may cut the same profile as device 400. Cutting inserts 548 may be cylindrical and include serrated or scalloped cutting edges and may produce a roughened or ridged tissue surface. In some examples, serrations may be aligned or misaligned in order to leave a smooth or roughened surface as desired.

[00109] Figure 45 depicts a cutting assembly 556 having seven identical cutting inserts 558. It is appreciated that cutting assembly 556 may be assembled with housing assembly 404 with appropriate modifications to the distribution of bushings 422, and drive assembly 402, to create a tissue cutting device which may cut the same profile as device 400. Cutting inserts 558 may be cylindrical and include serrated or scalloped cutting edges and may produce a roughened or ridged tissue surface.

[00110] Figures 46-55 depict other cutting profiles which may be created by the instruments and

methods disclosed herein. For each profile shown, a cutting member may be assembled comprising one or more cutting inserts as disclosed herein. The cutting inserts have straight cutting edges, curved cutting edges, or a combination thereof to create each profile. It is also appreciated that other profiles not specifically shown may be created using the instruments and methods disclosed herein. For example, the shapes shown in the various profiles of Figures 39 and 46-55 may be mixed and matched to create other profiles attainable by the instruments and methods disclosed herein.

[00111] The following disclosure is made in the context of femoroacetabular impingement (FAI) surgery of the hip for the purposes of illustration. The principles of the disclosed technology are applicable to a variety of other tools and instruments beyond the scope of FAI.

[00112] Referring to FIG. 56, a tissue resection device 601 may include a drive adapter hub 602, a hollow member 603, and a rotary cutting member 607. The hollow member 603 has a proximal end 605, a distal end 604, and a central axis 606. The drive adapter hub 602 is coupled to the hollow member 603 at the proximal end 605. The rotary cutting member 607 is disposed at the distal end 604 of the hollow member 603. The rotary cutting member 607 may be described as a burr. The tissue resection device 601 may also incorporate a suction port 608 to aid in removing tissue debris. In some examples, the drive adapter hub 602 may be adapted for grasping the tissue resection device and manipulating the position of the tissue resection device in any direction or orientation. For example, the drive adapter hub 602 may be adapted to interact with a powered hand piece (not shown) forming a handle for grasping the tissue resection device and manipulating the position of the tissue resection device in any direction or orientation. In other examples, the drive adapter hub 602 may include an integral handle formed thereon. In still other examples, the drive adapter hub 602 may be externally textured or may have a high friction outer surface for grasping.

[00113] FIG. 57 shows the tissue resection device 601 from a side view. The hollow member 603 may have an opening or window 617 formed in the distal end 604 of the hollow member 603. The opening or window 617 may be formed along the axis 606 of the hollow member 603 and sized and shaped to allow the rotary cutting member 607 to be partially exposed and protrude from the window 617. The shape of the window 617 in the direction of the axis 606 of the hollow member 603 may have edges 619 that are concave shaped and substantially similar to the concave shape of the rotary cutting member 607. The rotary cutting member 607 may protrude uniformly past the edges 619. The concave shaped edges 619 of the window 617 may thus act as depth stops to limit the amount of tissue that is resected during a single pass of the tissue resection device 601. In one example, the rotary cutting member 607 protrudes about 1.5 mm past the concave shaped edges 619 of the window 617. In other examples, the rotary cutting member 607 protrudes less than 1.5 mm beyond the concave shaped edges 619 of the window 617. In still other examples, the rotary cutting member 607 protrudes more than 1.5 mm beyond the concave shaped edges 619 of the window

617. In some examples, the user may selectively adjust the amount that the rotary cutting member 607 protrudes from the concave shaped edges 619 of the window 617.

[00114] The concave shaped edges 619 may also give the user better control by contacting the tissue during resection on one or both sides of the rotary cutting member 607. The edges 619 may provide stability to the resection device 601 by resisting twisting forces caused by the rotary cutting member as it spins and resects tissue. The edges 619 may also provide stability to the resection device by providing a multi-contact stabilizing reference to help the user keep the burr or rotary cutting member 607 in the desired position, similar to a tripod or a tool rest. For example, there may be a first contact point or area between the burr 607 and the tissue as the burr 607 resects the tissue; a second contact point or area between the tissue and a first concave shaped edge 619, and a third contact point or area between the tissue and a second concave shaped edge 619 opposite the first concave shaped edge. Each additional contact point provides greater stability and control to the user.

[00115] A distal top portion 618 of the hollow member 603 may be entirely or partially formed of transparent material to allow the user to see the rotary cutting member 607 during use. In some examples, the rotary cutting member 607 may be fully exposed with no distal top portion 618 or protective hood 621 (discussed below) adjacent the rotary cutting member 607, or any window 617 with concave shaped edges 619 to act as depth stops.

[00116] FIG. 58 shows a bottom view of the tissue resection device 601 illustrating the window 617 formed in the hollow member 603 and the concave or hourglass shaped rotary cutting member 607 exposed through the window 617. The rotary cutting member 607 may have an elongated body 609 that lies along an elongate body central longitudinal axis 627. In some examples, the rotary cutting member 607 may be coaxial with the axis 606 of the hollow member 603. In other examples, the axis 627 may be parallel to the axis 606.

[00117] FIG. 59 shows the tissue resection device 601 with the hollow member 603 removed to expose a drive member 616. The drive member 616 may transmit rotational forces, or torque, from the hub 602. The hub 602 may transmit torque from a powered hand piece (not shown), which may be connected to a suitable power source (not shown). The hub 602 may include a drive feature 631, for example a triangular, rectangular, square, or hexagonal shaft, for complementary interconnection with the powered hand piece.

[00118] The rotary cutting member 607 may have one or more cutting features on the elongate body 609. FIG. 59 shows an example with cutting flutes along the length of the elongate body 609 of the rotary cutting member 607. The cutting flutes may be of any size, shape, or number. The cutting flutes may be axial as shown, or they may be helical clockwise or counterclockwise. The cutting flutes may cross to produce a diamond pattern of cutting projections. The rotary cutting

member 607 may have a first portion 612, a second portion 614, a third or middle portion 613, and a fourth portion 615. The rotary cutting member 607 may have a concave or hourglass shape between the proximal end 610 and the distal end 611 of the rotary cutting member 607. The first portion 612 may have a first width or diameter, the second portion 614 may have a second width or diameter, and the middle portion 613 may have a third width or diameter. The first width of the first portion 612 and the second width of the second portion 614 may be greater than the third width of the middle portion 613 to form a concave curve between the first portion 612 and the second portion 614 of the rotary cutting member 607. The first, second, and third widths or diameters may be measured over the cutting features, and may thus correspond to the dimensions cut by the rotary cutting member 607. The concave shape of the rotary cutting member 607 may be chosen to substantially correspond to the natural or desired curvature of the tissue to be resected. For example, the concave shape of the rotary cutting member 607 may be chosen to substantially correspond to the natural curvature of the femoral neck of a human bone. In other examples, the concave shape of the rotary cutting member 607 may be chosen to substantially correspond to the natural or desired curvature of any tissue including, but not limited to, any bone, cartilage, soft tissue, and the like.

[00119] Continuing with FIG. 59, rotary cutting member 607 may have a fourth portion or end cutter 615 formed on the distal end 611 of the elongate body 609 of the rotary cutting member 607. In some examples, the end cutter portion 615 is at least partially hemispherical in shape. In other examples, the end cutter portion 615 may be substantially flat, conical, dished, or another shape. The end cutter portion 615 may have flutes, cutting members, or abrasive material formed thereon and configured to resect tissue. For example, the end cutter portion 615 may be useful in removing pincer-type bone impingements on an acetabular rim during femoral acetabular impingement (FAI) surgery. In other examples, the rotary cutting member 607 may terminate in a smooth non-cutting end portion instead of an end cutter.

[00120] FIGS. 60-64 illustrate another tissue resection device 640 that is similar to device 601, but includes an outer sheath 620 having a protective hood 621 and a protective hood window 623 formed on the distal end of the outer sheath 620. In this example, the outer sheath 620 is a tubular structure that fits over a hollow member 603. The protective hood window 623 may be similar to window 617. The window 623 may be formed along the axis 606 of the hollow member 603 and sized and shaped to allow the rotary cutting member 607 to be partially exposed and protrude from the protective hood window 623 formed in the hollow member 603. The shape of the protective hood window 623 in the direction of the axis 606 of the hollow member 603 may have edges 624 that are concave and substantially similar to the concave shape of the rotary cutting member 607. The concave shaped edges 624 of the protective hood window 623 may thus act as depth stops to

limit the amount of tissue that is resected during a single pass of the tissue resection device 640. The protective hood may be made of transparent material to help the user visualize the placement and action of the rotary cutting member 607. In one example, the outer sheath 620 may be rotated by manipulating the control member 625 located at a proximal end of the outer sheath 620. For example, a user may apply compressive and/or rotational forces to tabs 626 of the control member 625 to rotate the outer sheath 620 about the hollow member 603 and control the position of the protective hood 621 relative to the rotary cutting member 607. In this manner, the protective hood 621 may be selectively positioned to expose the rotary cutting member 607 to allow tissue to be resected, or positioned to cover the rotary cutting member 607 to prevent tissue from being resected, or positioned to partially cover the rotary cutting member 607.

[00121] FIGS. 60, 61, and 63 show the tissue resection device 640 with the outer sheath 620 rotationally oriented such that the protective hood window 623 of the outer sheath 620 is aligned with the window 617 of the hollow member 603. This allows the rotary cutting member to be exposed through both windows 623, 627 and enables the rotary cutting member 607 to resect tissue. FIGS. 62 and 64 show the tissue resection device 640 with the outer sheath 620 rotationally oriented such that the protective hood window 623 of the outer sheath 620 faces the window 617 of the hollow member 603. This covers up the rotary cutting member 607 and prevents the rotary cutting member 607 from resecting tissue along the curved portion of the rotary cutting member 607. In some examples, the end-cutting portion 615 of the rotary cutting member 607 always remains exposed at the distal tip of the tissue resection device 640 regardless of the rotational orientation of the outer sheath 620. In other examples, the end-cutting portion 615 of the rotary cutting member 607 may be selectively covered or uncovered to allow or prevent the end-cutting portion 615 from resecting tissue. In one such example, the outer sheath 620 and the hollow member 603 may extend distally to cover some of the end-cutting portion 615. When the protective hood window 623 of the outer sheath 620 is aligned with the window 617 of the hollow member 603, some of the end-cutting portion 615 is exposed. When the protective hood window 623 of the outer sheath 620 faces the window 617 of the hollow member 603, the end-cutting portion 615 is covered up. In another such example, the outer sheath may be translatable along the axis 606 of the hollow member 603 to cover portions of the rotary cutting member 607. For example, the outer sheath 620 may be translated in the distal direction to substantially cover up all or a portion of the hourglass and/or end cutting portions 615 of the tissue resection device 640. Thus, it will be understood, that the outer sheath 620 may be both rotatably and axially positionable.

[00122] It is to be understood that a rotatable or translatable protective hood 621 may be used with any surgical instrument, besides burrs, to cover up the end effector disposed at the distal end of the hollow member 603. Example end effectors include, but are not limited to: grasping jaws,

dissectors, suture passers, staplers, tissue cutters, rasps, ablation devices, microfracture devices, scalpels, shavers, cameras, sensors, etc., or any other end effector or structure.

[00123] With reference to FIG. 63, it may be seen that when the outer sheath 620 is rotated to the open position, the rotary cutting member 607 and the suction port are exposed through the window 623 and the suction created by suction port 608 is proximal to the rotary cutting member 607. Thus, suction power is positioned close to the curved portion of the rotary cutting member 607 where it is needed to remove tissue debris. In contrast, when the outer sheath 620 is rotated to the closed position, the protective hood 621 covers the curved portion of the rotary cutting member 607 and the suction port 608. This directs suction distally toward the end-cutting portion 615 of the rotary cutting member 607, as may be seen in FIG. 64. Thus, the design of the outer sheath 620 automatically shifts fluid suction between the proximal part of the rotary cutting member 607 to the distal end-cutting portion 615 of the rotary cutting member 607 as the outer sheath 620 is rotated.

[00124] Similarly, in other examples, the outer sheath 620 may be axially translatable to automatically direct fluid suction forces between the proximal part of the rotary cutting member 607 and the distal end-cutting portion 615 of the rotary cutting member as the outer sheath 620 translates back and forth in the axial direction.

[00125] The components disclosed herein may be fabricated from metals, alloys, polymers, plastics, ceramics, glasses, composite materials, or combinations thereof, including but not limited to: PEEK, titanium, titanium alloys, commercially pure titanium grade 2, ASTM F67, Nitinol, cobalt chrome, stainless steel, ultra high molecular weight polyethylene (UHMWPE), biocompatible materials, and biodegradable materials, among others. Different materials may be used for different parts. Different materials may be used within a single part. Any component disclosed herein may be colored, coded or otherwise marked to make it easier for a user to identify the type and size of the component, the setting, the function(s) of the component, and the like.

[00126] It should be understood that the present systems, kits, apparatuses, and methods are not intended to be limited to the particular forms disclosed. Rather, they are to cover all combinations, modifications, equivalents, and alternatives falling within the scope of the claims.

[00127] The claims are not to be interpreted as including means-plus- or step-plus-function limitations, unless such a limitation is explicitly recited in a given claim using the phrase(s) "means for" or "step for," respectively.

[00128] The term "coupled" is defined as connected, although not necessarily directly, and not necessarily mechanically.

[00129] The use of the word "a" or "an" when used in conjunction with the term "comprising" in the claims and/or the specification may mean "one," but it is also consistent with the meaning of "one or more" or "at least one." The term "about" means, in general, the stated value plus or minus

5%. The use of the term "or" in the claims is used to mean "and/or" unless explicitly indicated to refer to alternatives only or the alternative are mutually exclusive, although the disclosure supports a definition that refers to only alternatives and "and/or."

[00130] The terms "comprise" (and any form of comprise, such as "comprises" and "comprising"), "have" (and any form of have, such as "has" and "having"), "include" (and any form of include, such as "includes" and "including") and "contain" (and any form of contain, such as "contains" and "containing") are open-ended linking verbs. As a result, a method or device that "comprises," "has," "includes" or "contains" one or more steps or elements, possesses those one or more steps or elements, but is not limited to possessing only those one or more elements. Likewise, a step of a method or an element of a device that "comprises," "has," "includes" or "contains" one or more features, possesses those one or more features, but is not limited to possessing only those one or more features. Furthermore, a device or structure that is configured in a certain way is configured in at least that way, but may also be configured in ways that are not listed.

[00131] In the foregoing Detailed Description, various features are grouped together in several examples for the purpose of streamlining the disclosure. This method of disclosure is not to be interpreted as reflecting an intention that the examples of the invention require more features than are expressly recited in each claim. Rather, as the following claims reflect, inventive subject matter lies in less than all features of a single disclosed example. Thus, the following claims are hereby incorporated into the Detailed Description, with each claim standing on its own as a separate example.

CLAIMS

1. A tissue resection device, comprising:
 - a hollow member having a proximal end, a distal end, and a longitudinal axis;
 - a drive member coupled to the proximal end of the hollow member; and
 - a rotary cutting member for side cutting, the rotary cutting member having an elongate body with a longitudinal axis, a proximal end, and a distal end, wherein the elongate body has a concave shape between the proximal end of the elongate body and the distal end of the elongate body along the longitudinal axis of the elongate body.
2. The tissue resection device of claim 1, wherein the rotary cutting member is coaxial with and received within the hollow member.
3. The tissue resection device of claim 1, wherein the longitudinal axis of the rotary cutting member is parallel to the longitudinal axis of the hollow member, wherein the rotary cutting member is received within the hollow member.
4. The tissue resection device of claim 1 further comprising:
 - an opening formed in the distal end of the hollow member along the longitudinal axis of the hollow member, the opening of the hollow member sized and shaped to partially expose the rotary cutting member through the opening of the hollow member, wherein the rotary cutter partially protrudes from the opening of the hollow member, wherein the shape of the opening of the hollow member along the longitudinal axis of the hollow member is concave and complementary to the concave shape of the rotary cutting member.
5. The tissue resection device of claim 4, wherein a distance that the rotary cutting member protrudes from the opening of the hollow member is selectively adjustable.
6. The tissue resection device of claim 1, wherein the elongate body of the rotary cutting member further comprises an end cutting portion formed in the distal end of the elongate body of the rotary cutting member.
7. The tissue resection device of claim 6, wherein the end cutting portion is at least partially hemispherical in shape.
8. The tissue resection device of claim 1, further comprising a protective hood adapted to partially surround the rotary cutting member.
9. The tissue resection device of claim 8, wherein the protective hood comprises an opening formed in a distal end of the protective hood along the longitudinal axis of the rotary cutting member, the opening of the protective hood being sized and shaped to partially expose the rotary cutting member through the opening of the protective hood, wherein the rotary cutter partially protrudes from the opening of the protective hood, wherein the shape of the opening of the protective hood along the longitudinal axis of the rotary cutting member is concave and complementary to the concave shape of the rotary cutting member.

10. The tissue resection device of claim 8, wherein the protective hood is rotatable about the longitudinal axis of the rotary cutting member to selectively cover and uncover the rotary cutting member.
11. The tissue resection device of claim 1, wherein at least a portion of the hollow member surrounding the rotary cutting member comprises a transparent material.
12. The tissue resection device of claim 1, wherein the rotary cutting member comprises:
 - a first portion having a first width;
 - a second portion having a second width; and
 - a middle portion having a third width, the middle portion intermediate the first portion and the second portion, wherein the first width of the first portion and the second width of the second portion are greater than the third width of the middle portion.
13. A surgical instrument, comprising:
 - a hollow member having a proximal end, a distal end, and a longitudinal axis;
 - an end effector disposed at the distal end of the hollow member; and
 - a protective hood, wherein the protective hood can be selectively moved to cover or uncover the end effector.
14. The surgical instrument of claim 13, wherein the protective hood can be selectively translated along the longitudinal axis to cover or uncover the end effector.
15. The surgical instrument of claim 14, further comprising a rotary cutting member comprising an elongate body with a longitudinal axis, a proximal end, and a distal end, wherein the elongate body has a concave shape between its proximal end and distal end along the longitudinal axis of the elongate body.
16. A tissue resection device, comprising:
 - a hollow member having a proximal end, a distal end, and a longitudinal axis;
 - a tissue resection end effector disposed at the distal end of the hollow member; and
 - a depth stop, to control the depth of tissue removed by the tissue resection end effector.
17. The tissue resection device of claim 16, wherein the depth stop is created by an opening formed in the hollow member along the longitudinal axis, the opening being sized and shaped to allow the tissue resection end effector to be partially exposed through the opening and protrude from the opening.
18. The tissue resection device of claim 17, wherein the shape of the opening is substantially similar to the shape of the tissue resection end effector.
19. The tissue resection device of claim 17, wherein the tissue resection end effector is a burr.
20. The tissue resection device of claim 17, wherein the tissue resection end effector is a rasp.

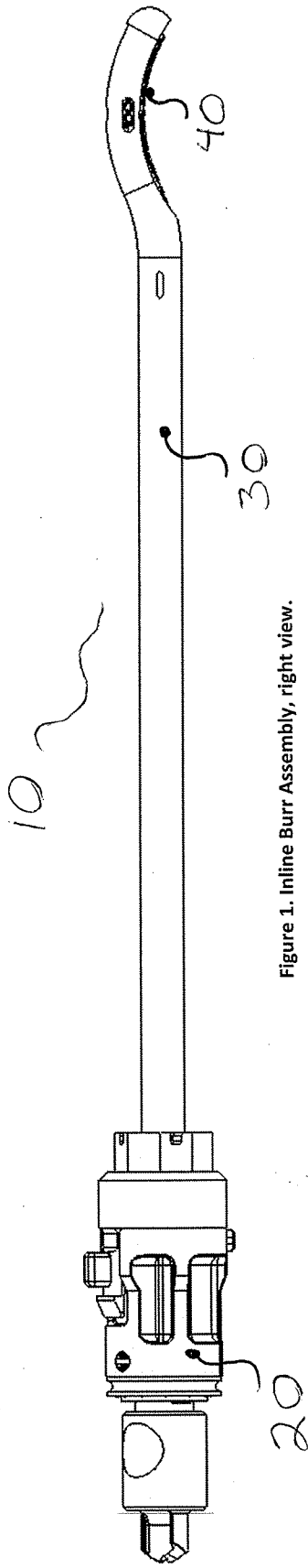

Figure 1. In-line Burr Assembly, right view.

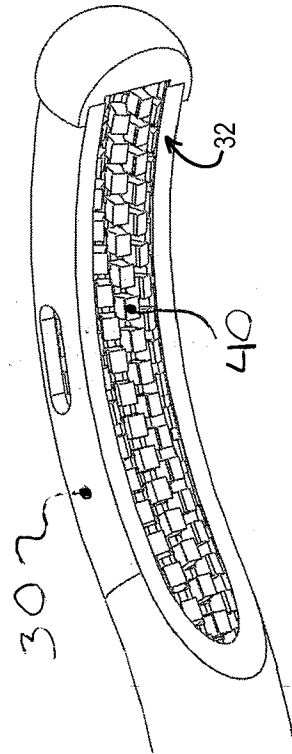

Figure 2a. In-line Burr Assembly Tip, isometric view.

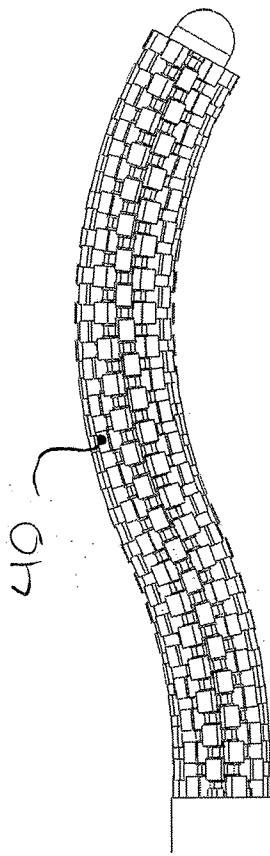

Figure 2b. In-line Burr Assembly Tip without outer sheath, right view.

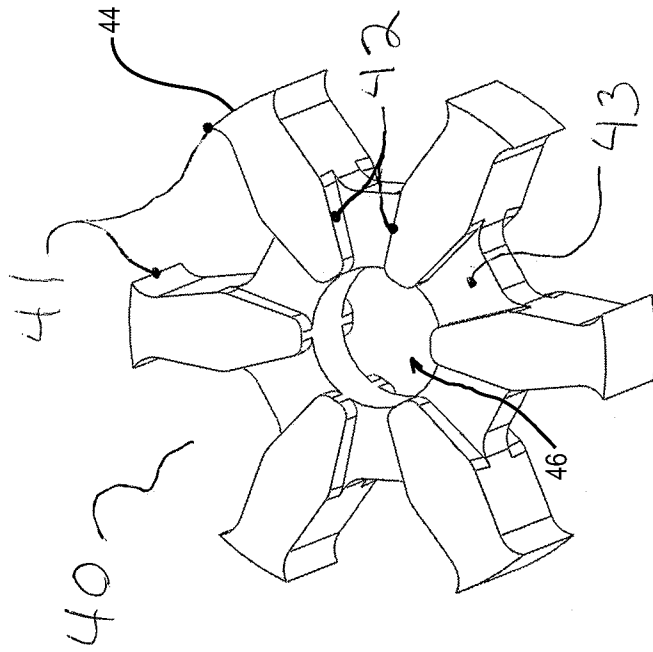

Figure 3. Interlocking Cutter, isometric view.

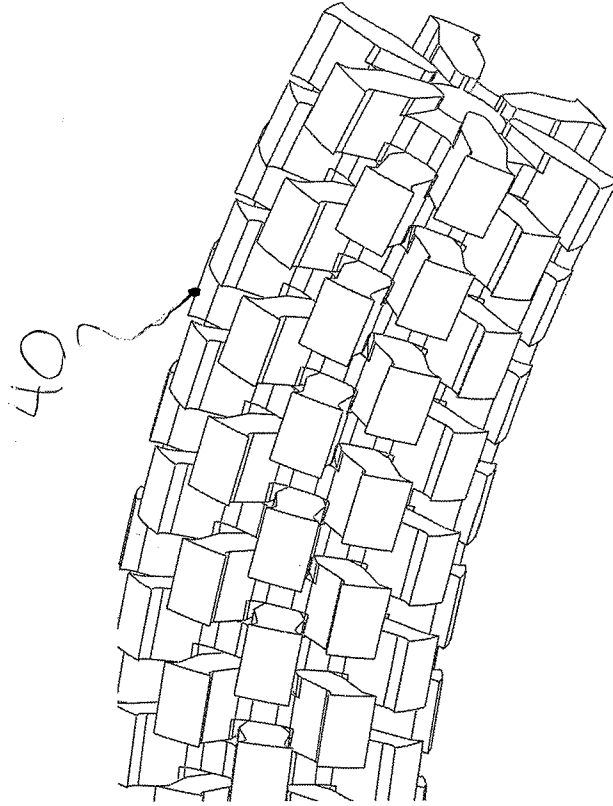

Figure 4. Interlocking Cutter Interaction, isometric view.

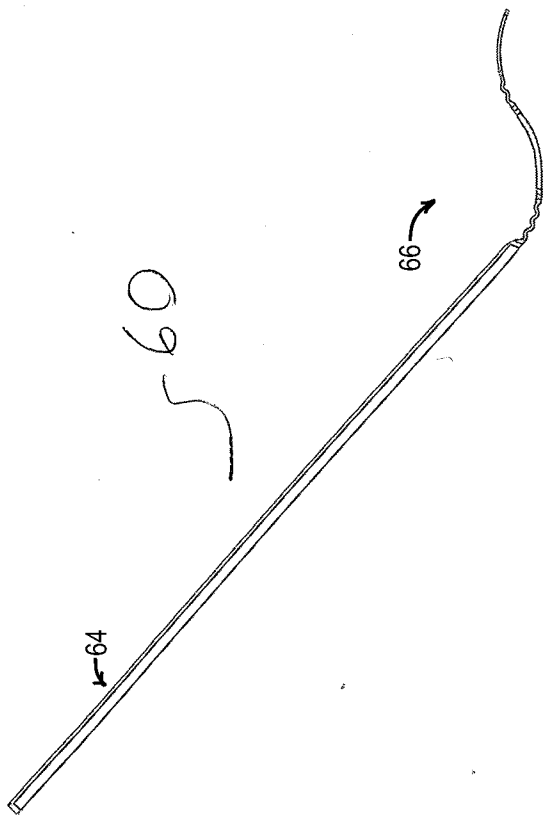

Figure 5. Flexible Measurement Device, right view.

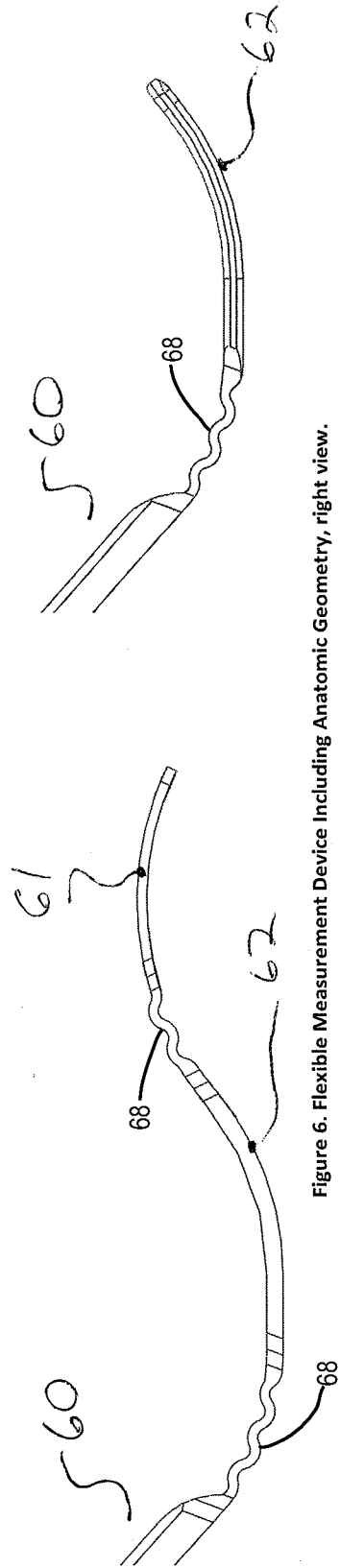

Figure 6. Flexible Measurement Device Including Anatomic Geometry, right view.

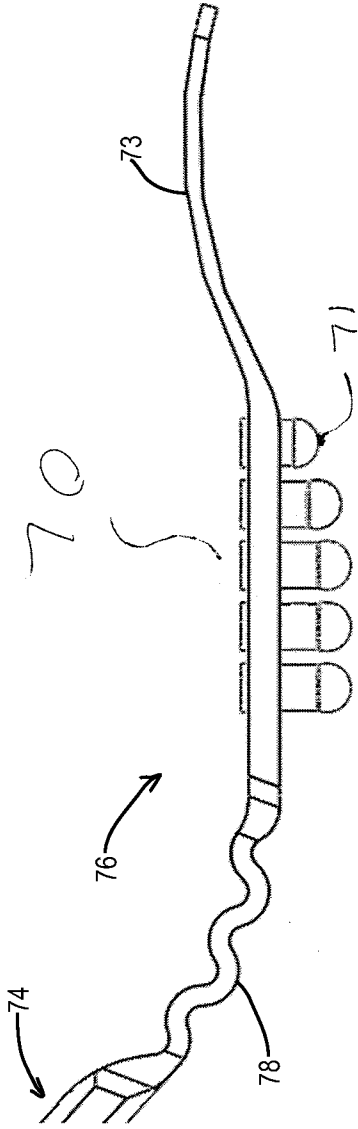

Figure 7. Pin Based Measurement Device, right view.

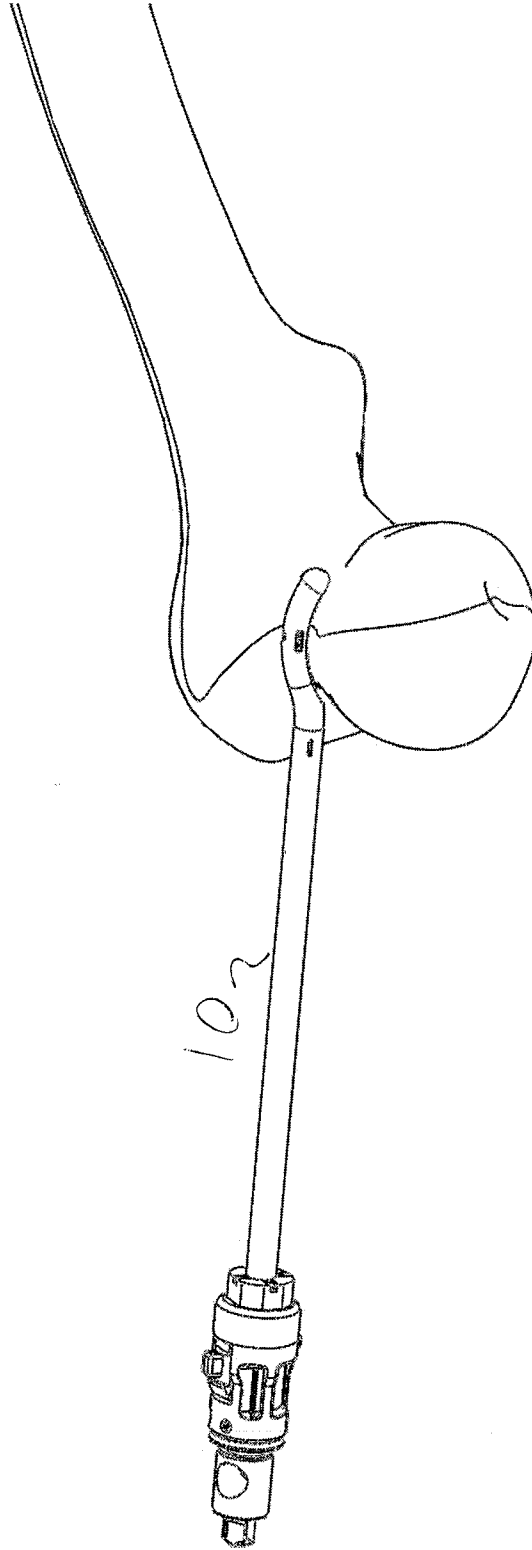

Figure 8. Inline Burr Approach to Femoral Neck, isometric view.

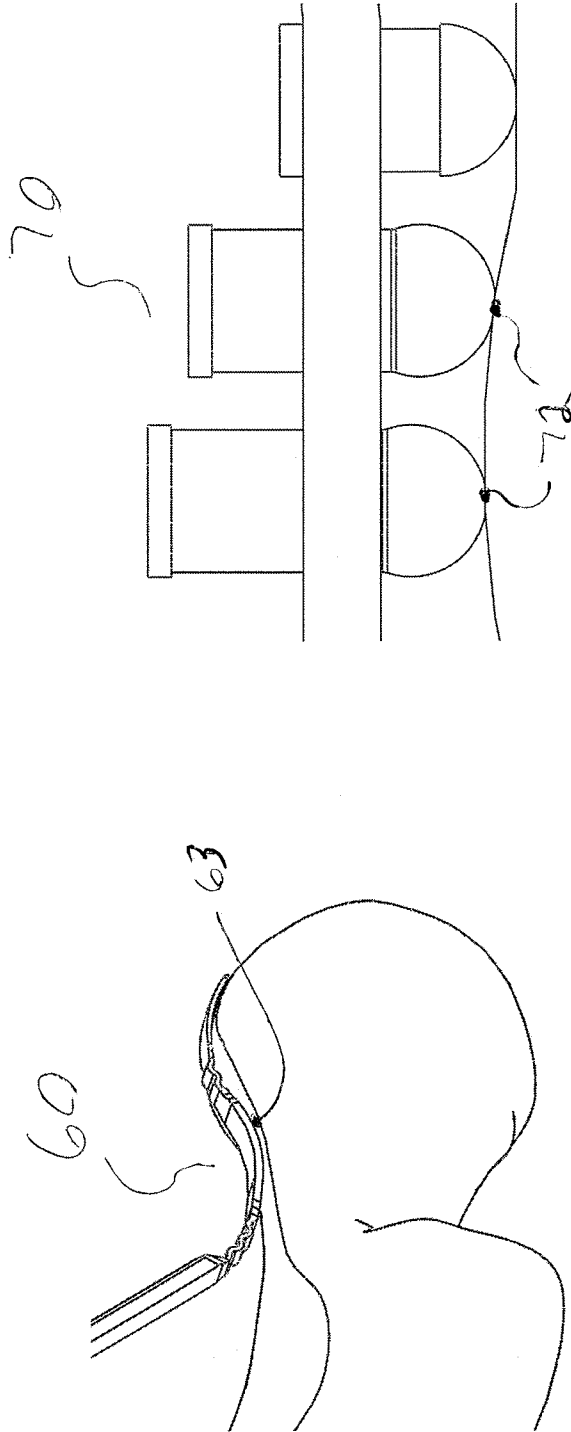

Figure 9. Flexible Measurement Device on Anatomy, isometric view.

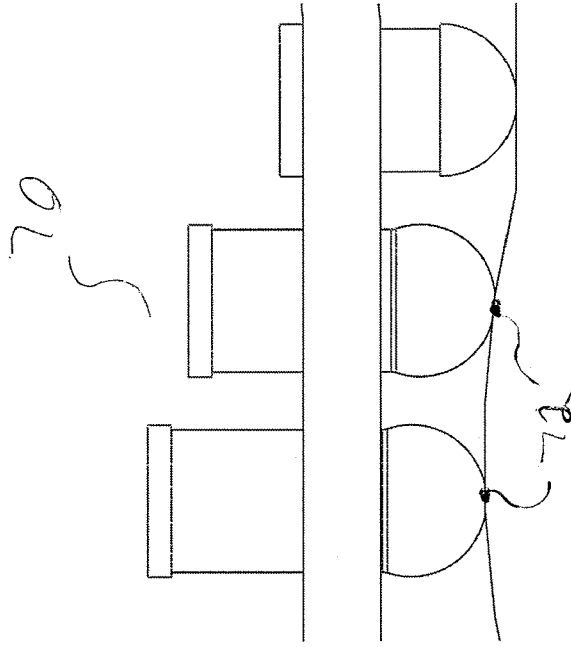

Figure 10. Pin Based Measurement Device Actuation, right view.

Alternate Embodiments

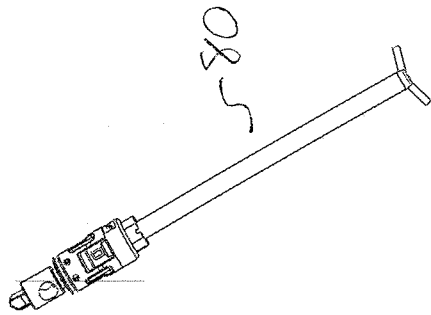

Figure 11a. Expanding Burr, isometric view.

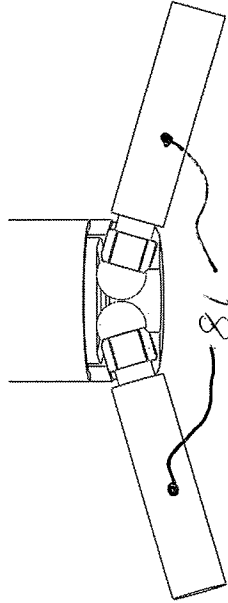

Figure 11b. Expanding Burr Deployed, isometric view.

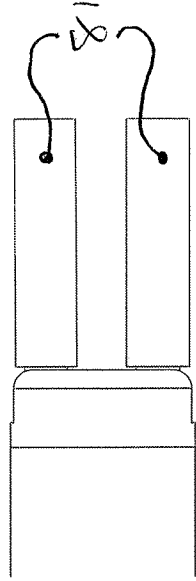

Figure 11c. Expanding Burr Retracted, right view.

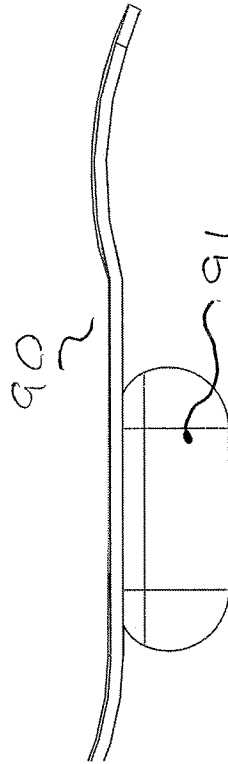

Figure 12. Bladder based Measurement Device, right view.

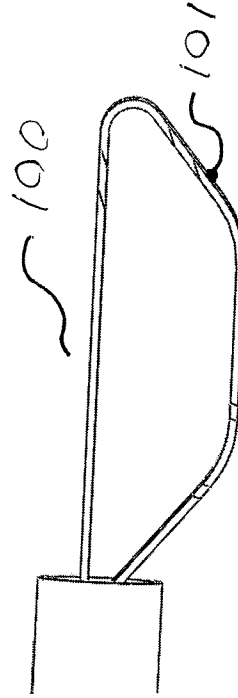

Figure 13. Spring based Measurement Device, isometric view.

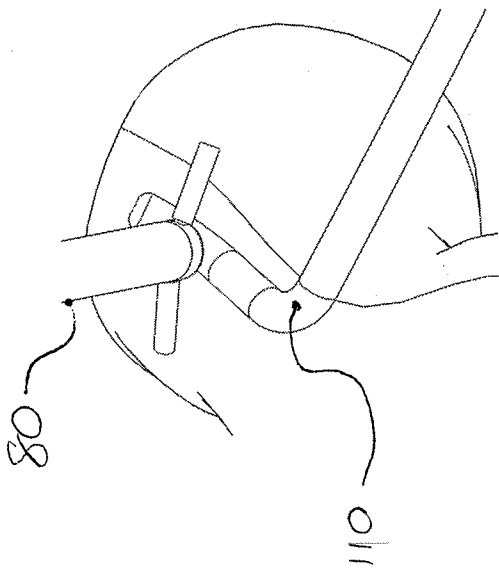

Figure 14. Fixed Guide, isometric view.

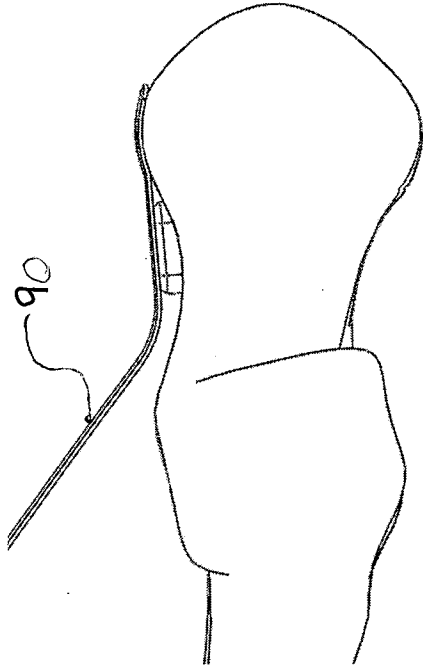

Figure 15. Bladder based Measurement Device, isometric view.

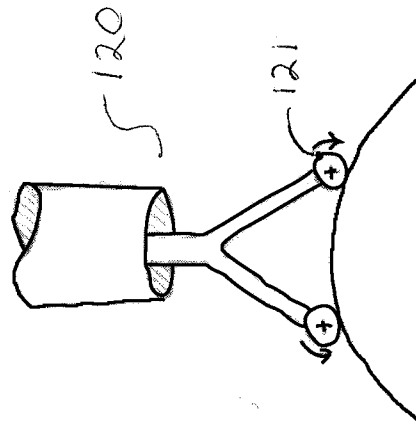

Figure 16. Deploying Grinder, front view.

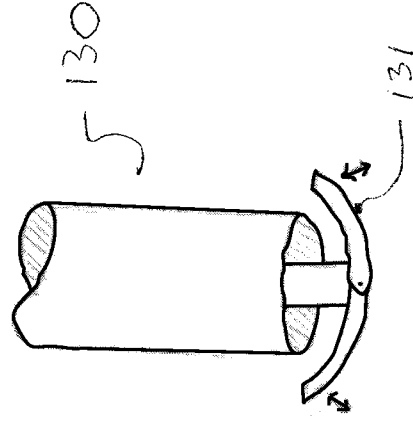

Figure 17. Deploying Grater, isometric view.

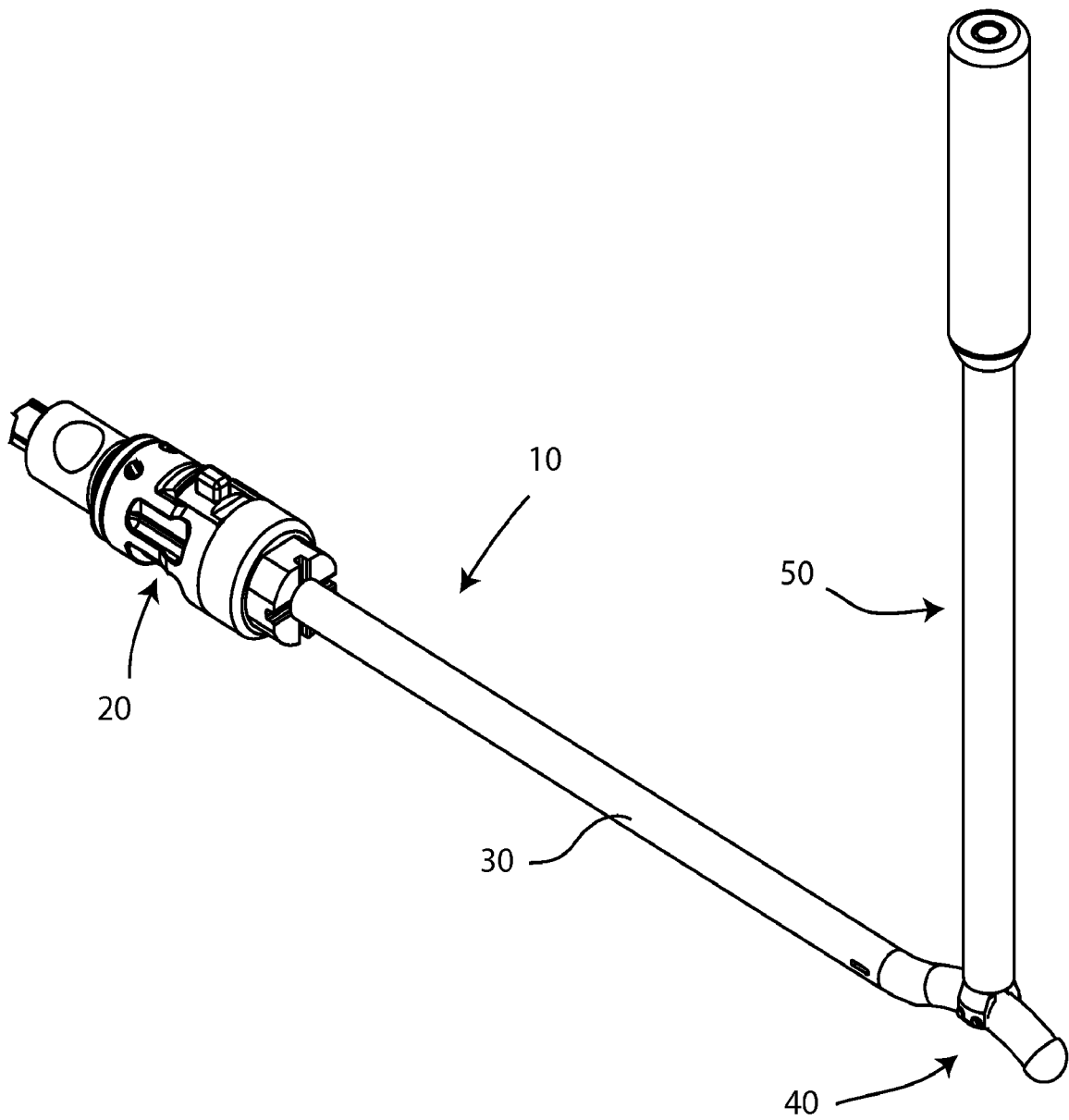

FIG. 18

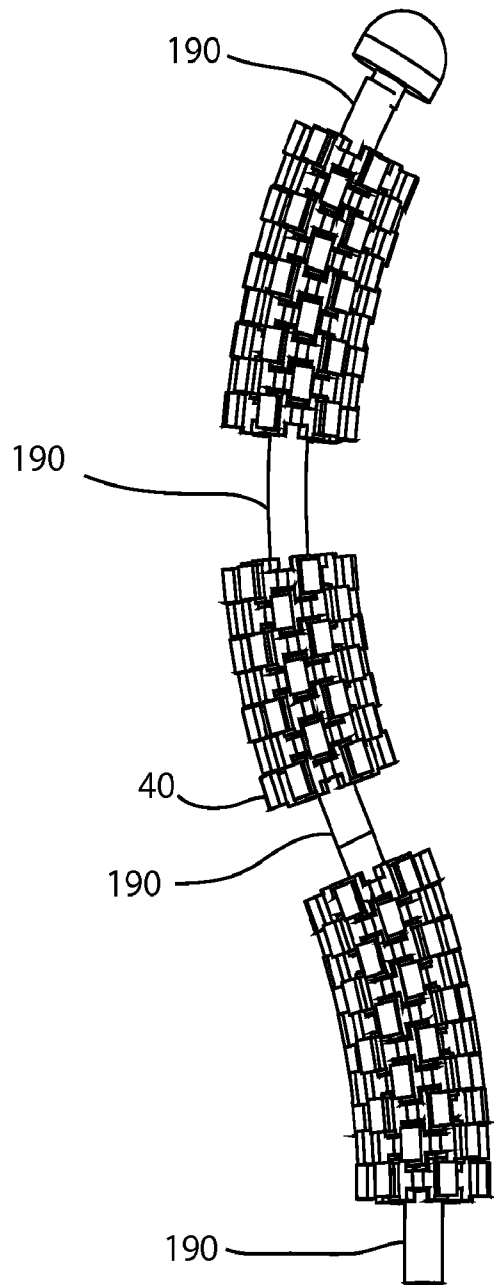

FIG. 19

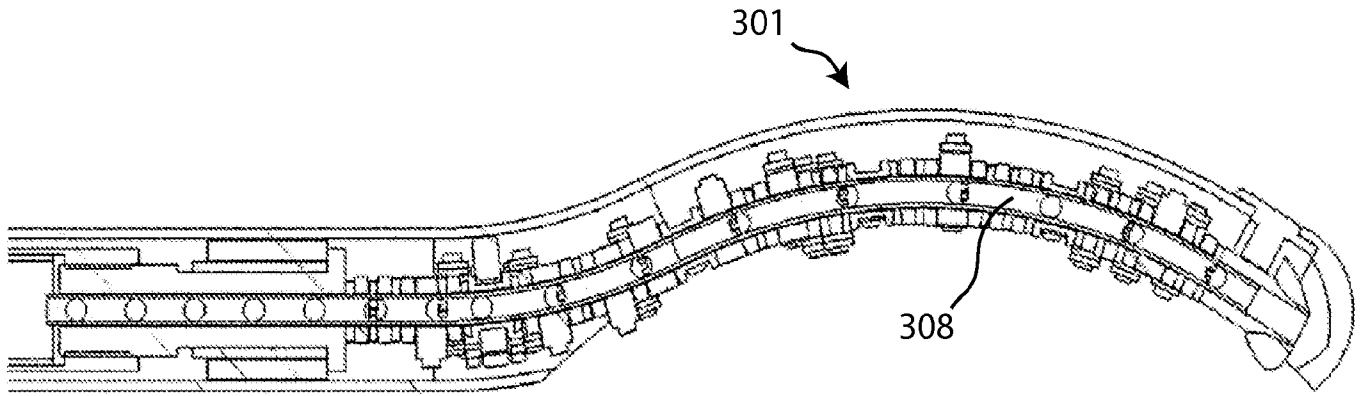

FIG. 20A

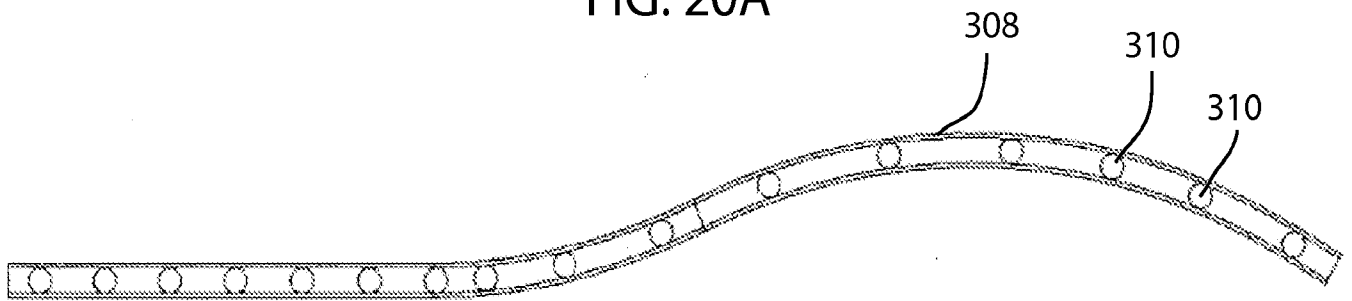

FIG. 20B

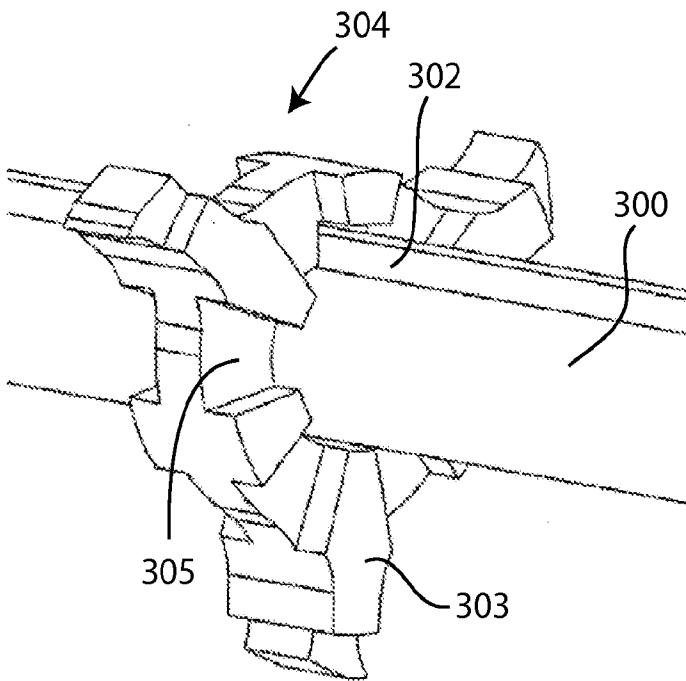

FIG. 20C

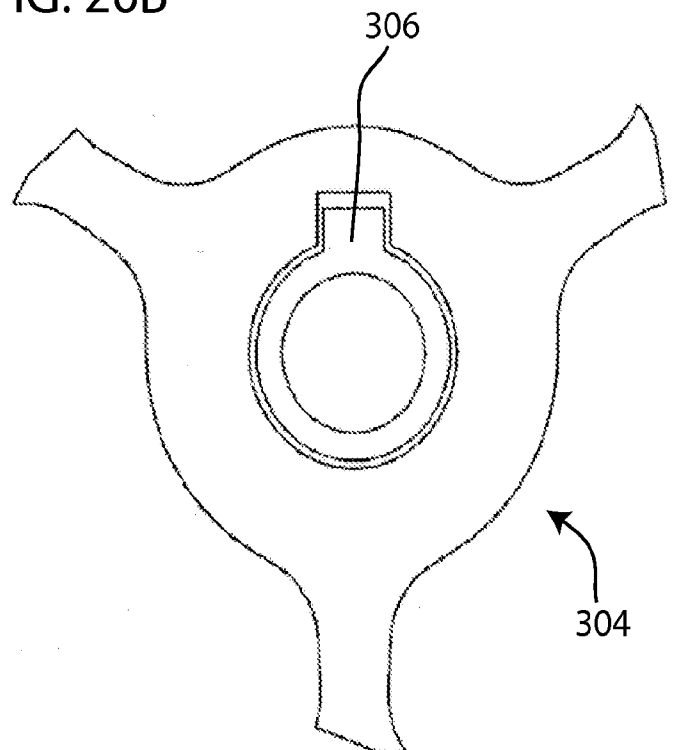

FIG. 20D

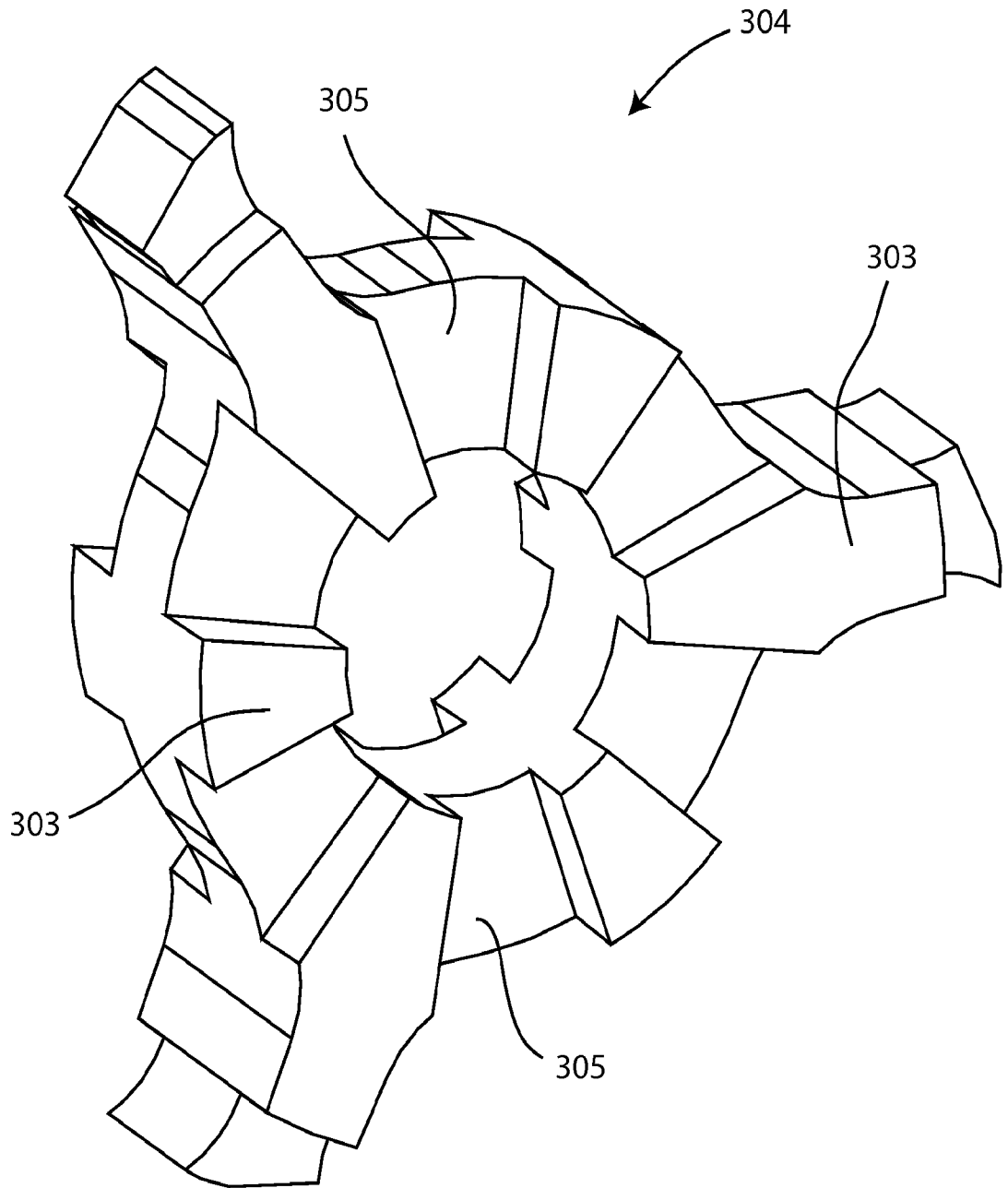

FIG. 21

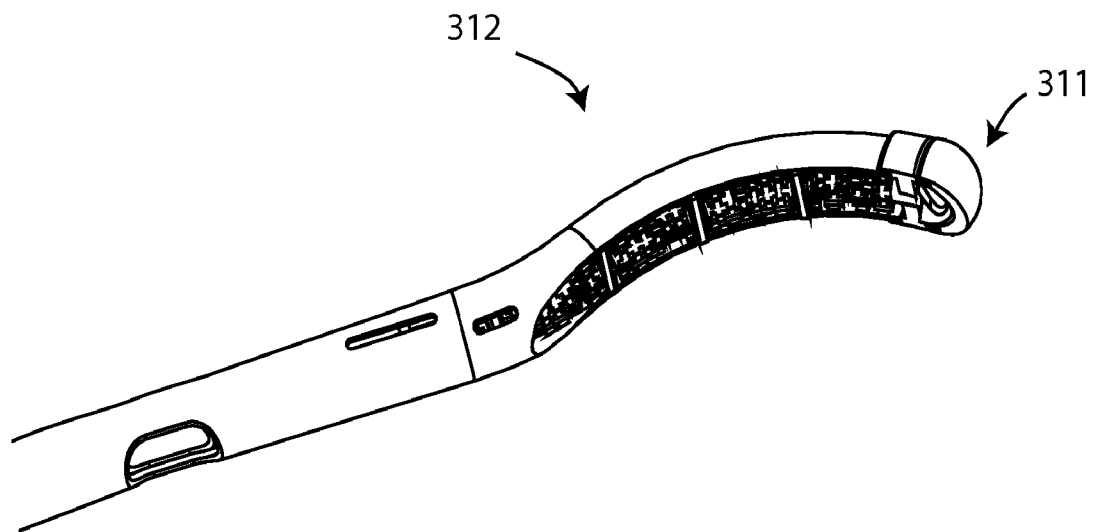

FIG. 22

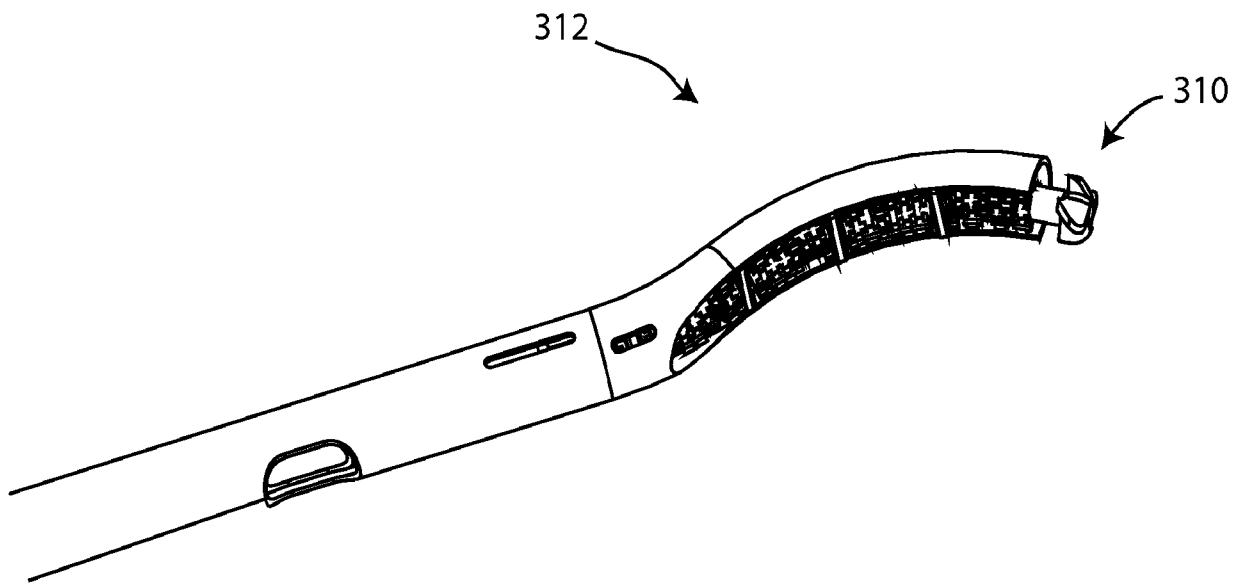
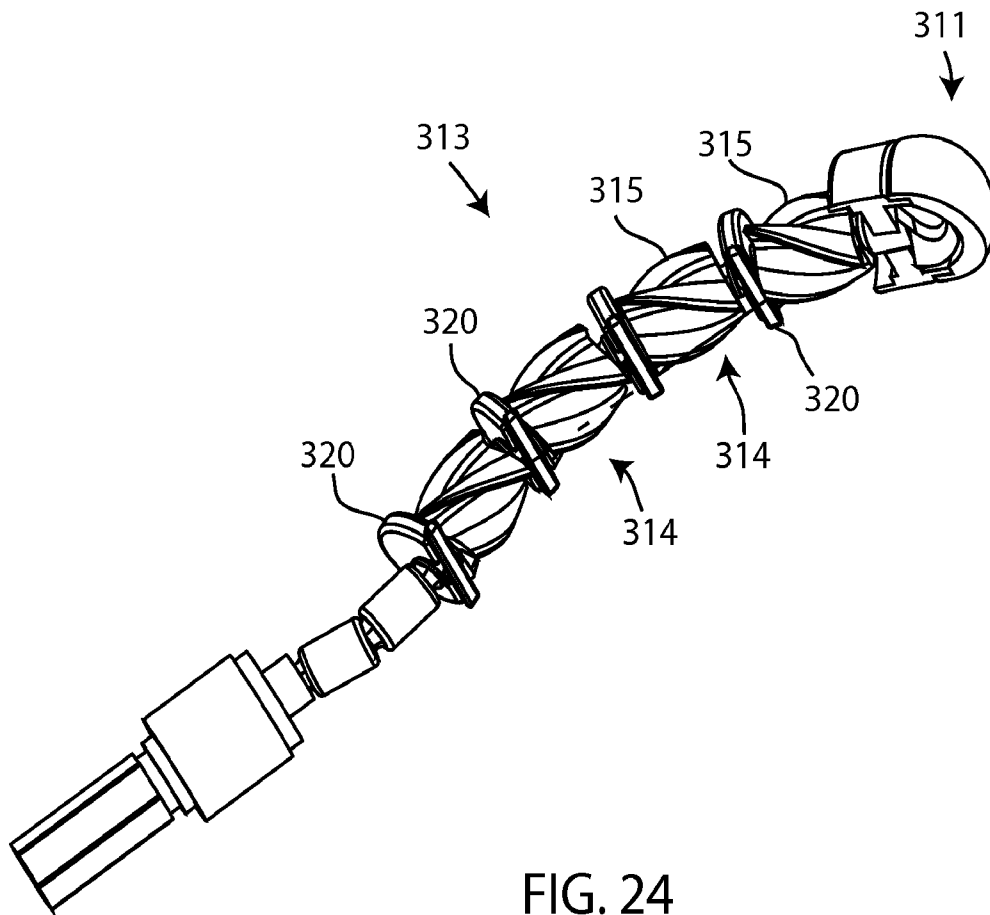

FIG. 23



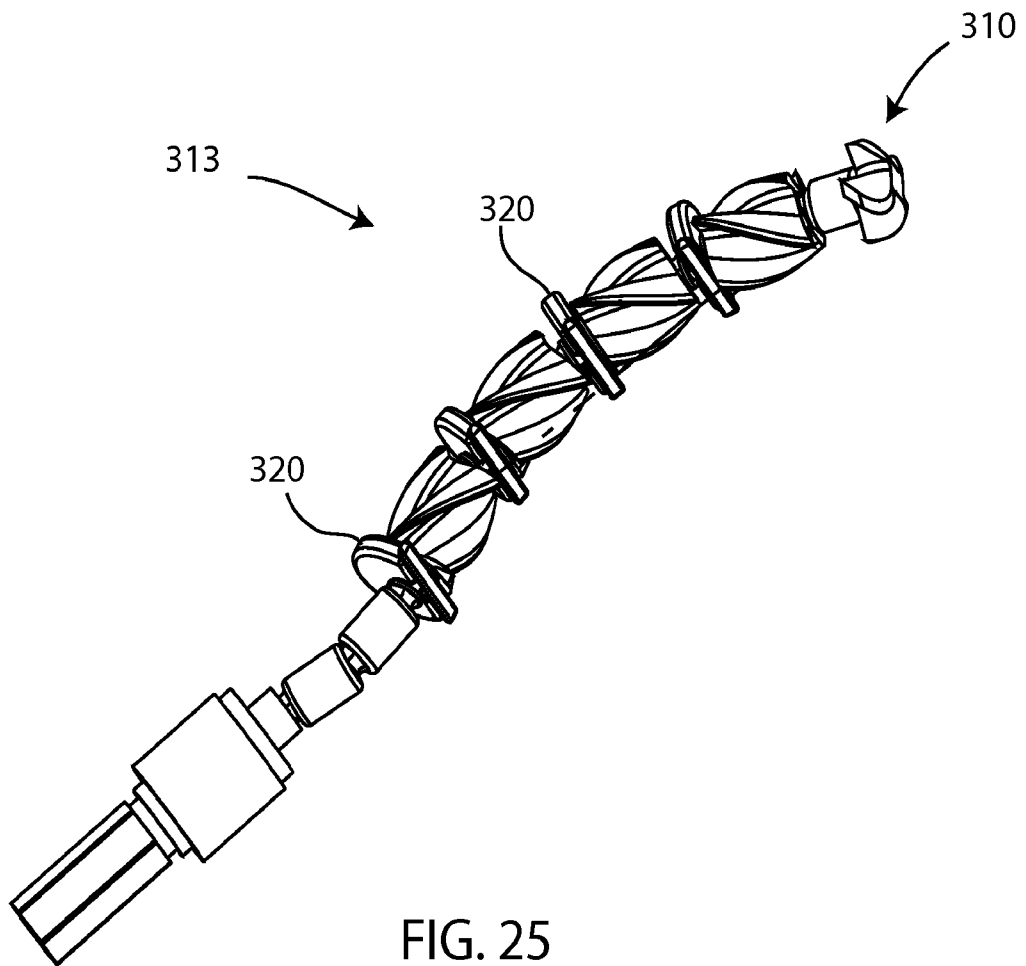

FIG. 25

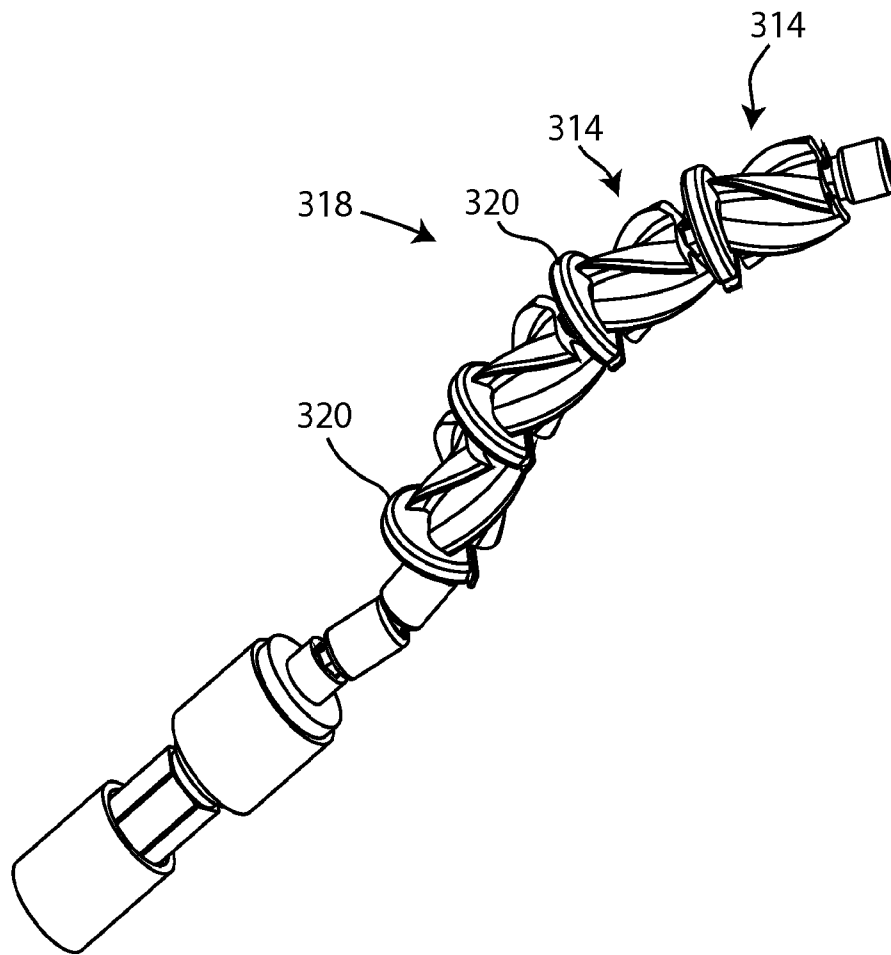

FIG. 26

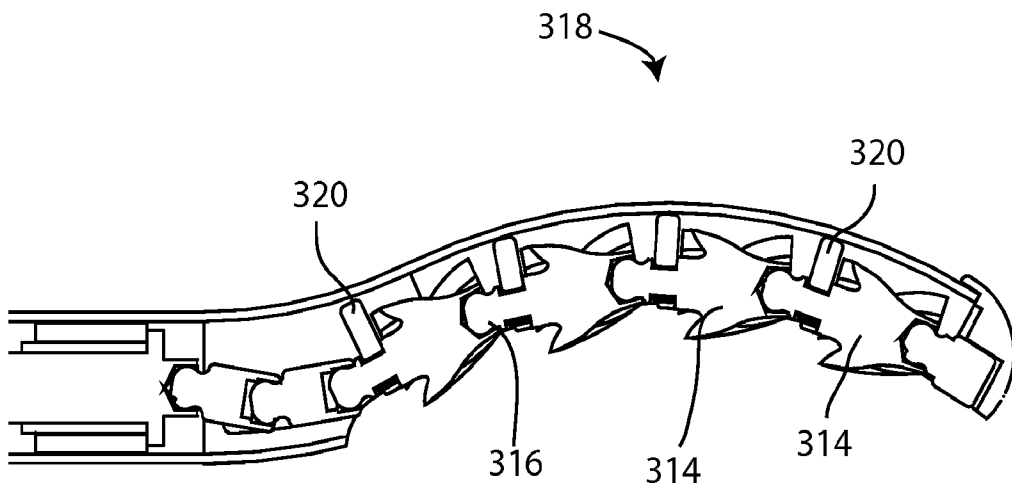

FIG. 27A

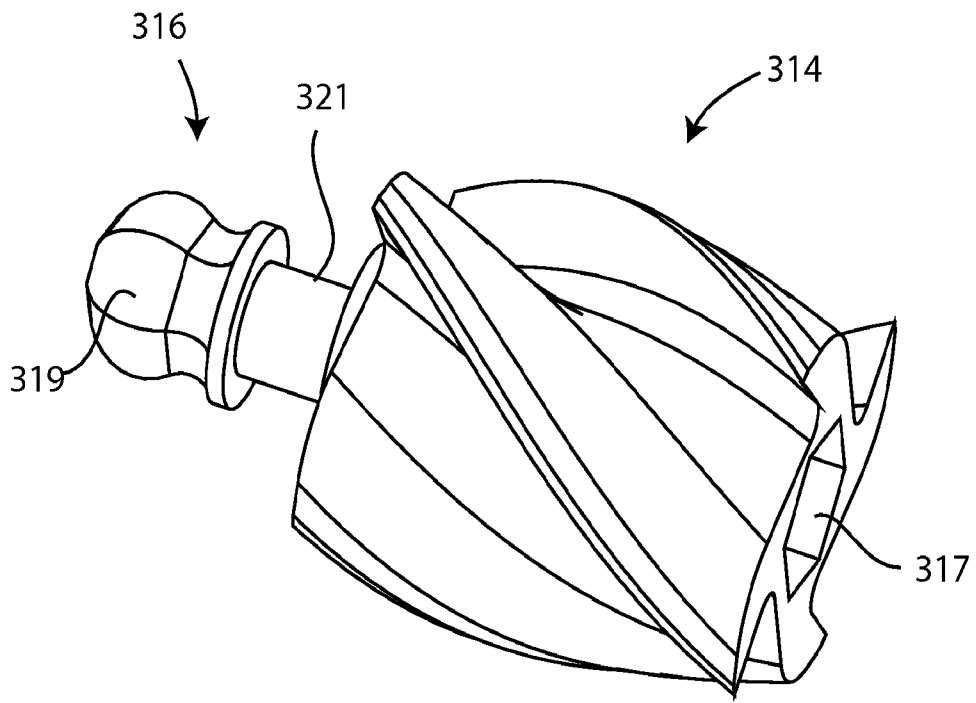

FIG. 27B

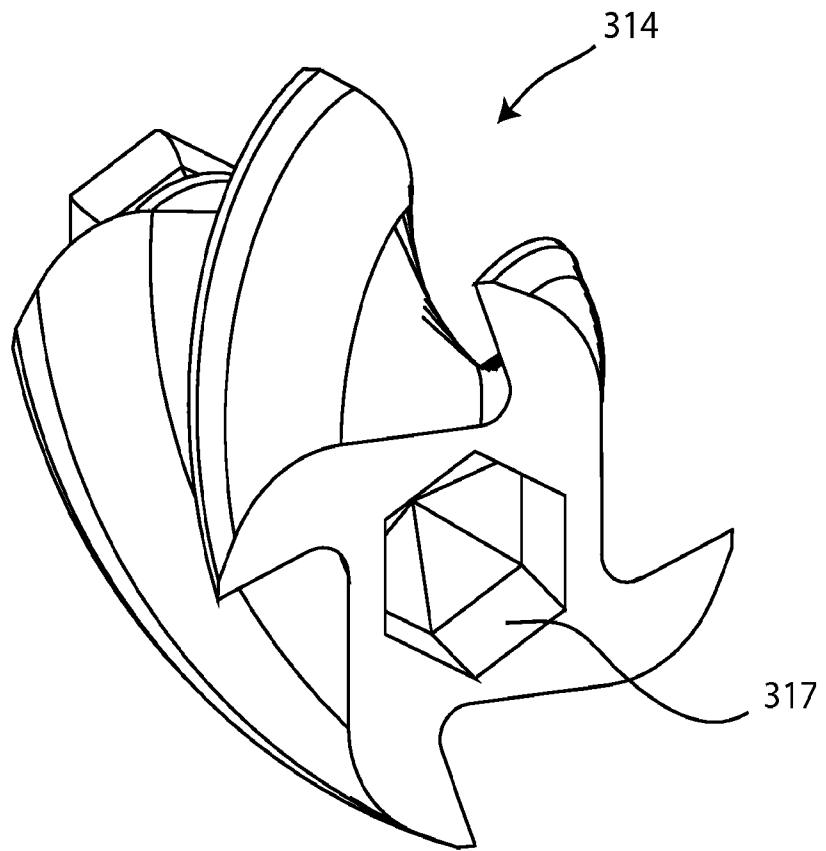

FIG. 27C

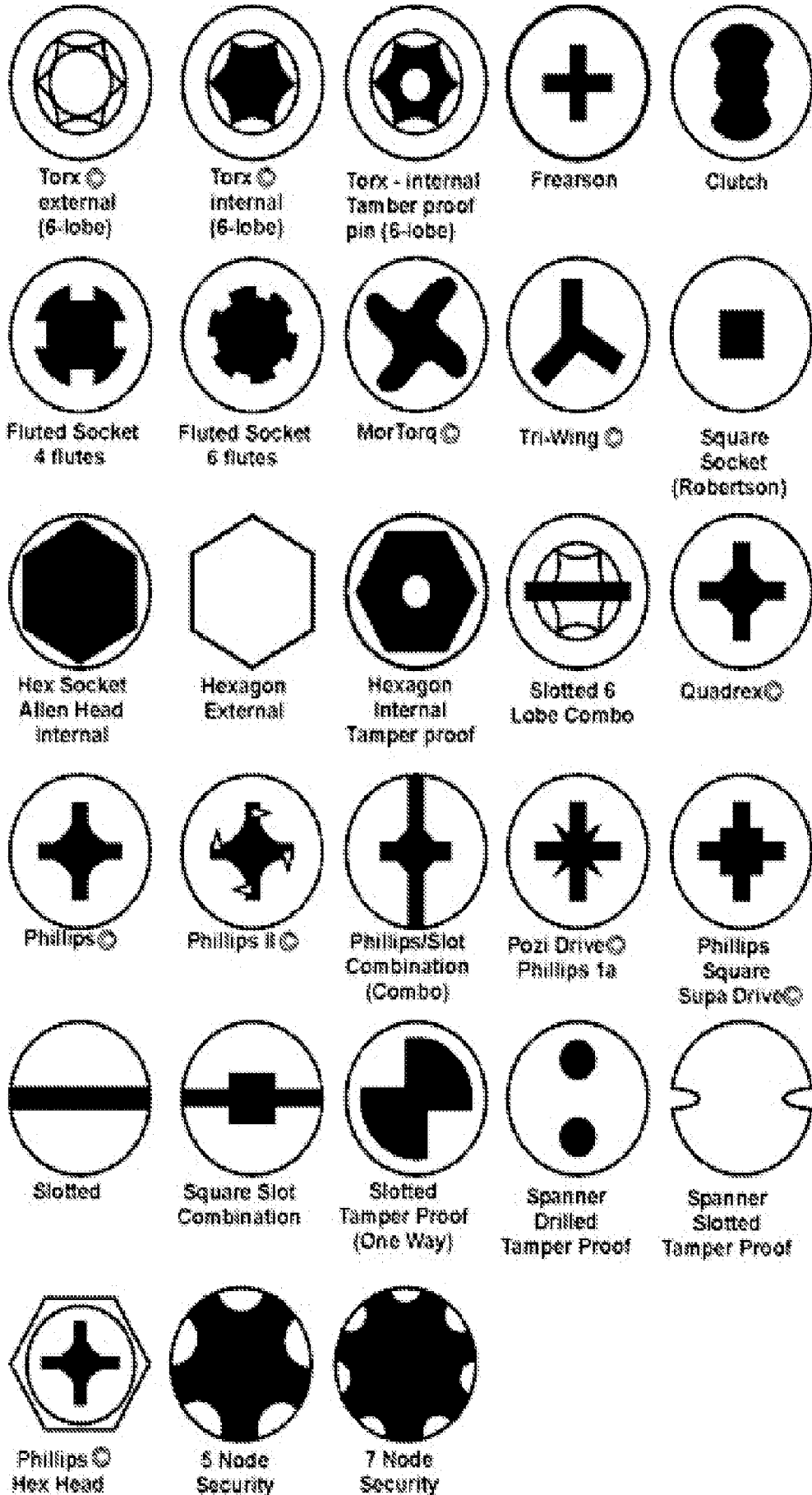

FIG. 27D

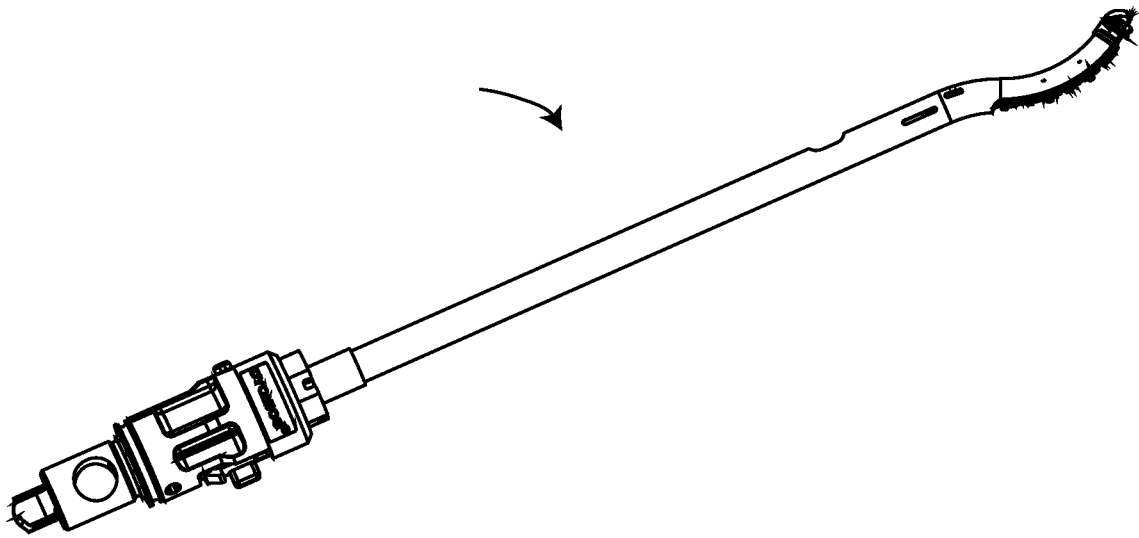

FIG. 28

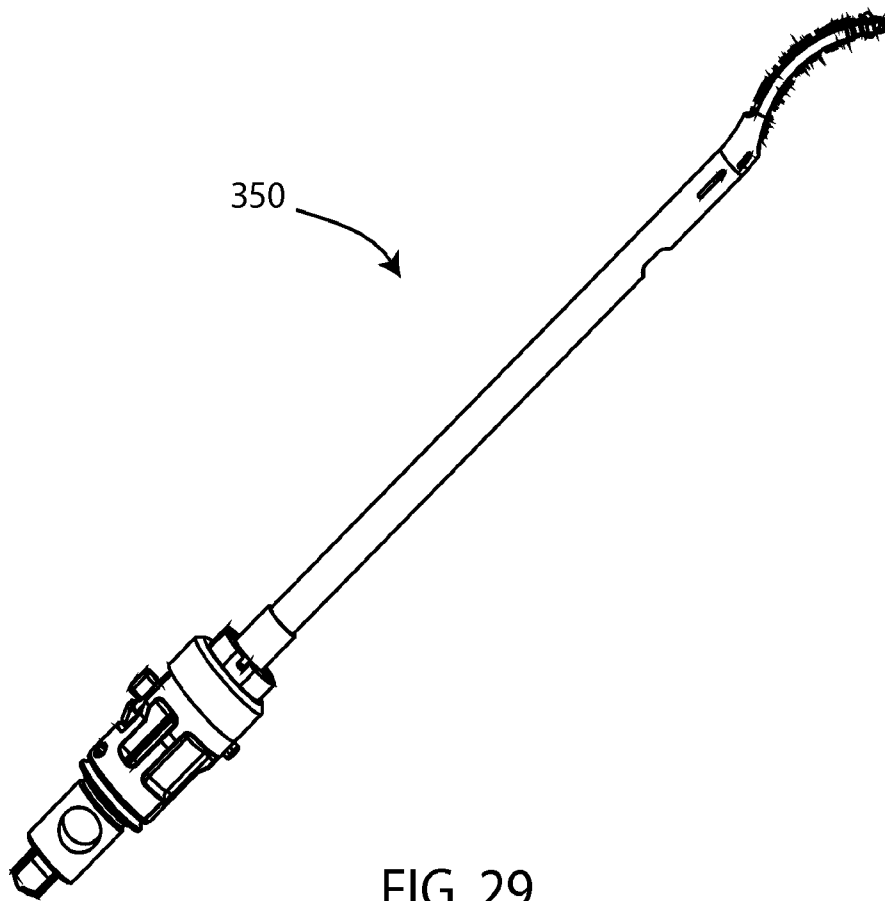

FIG. 29

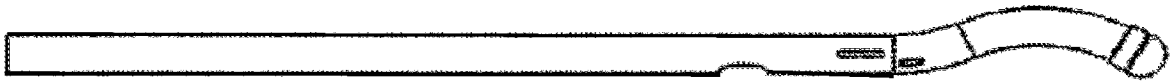

FIG. 30A

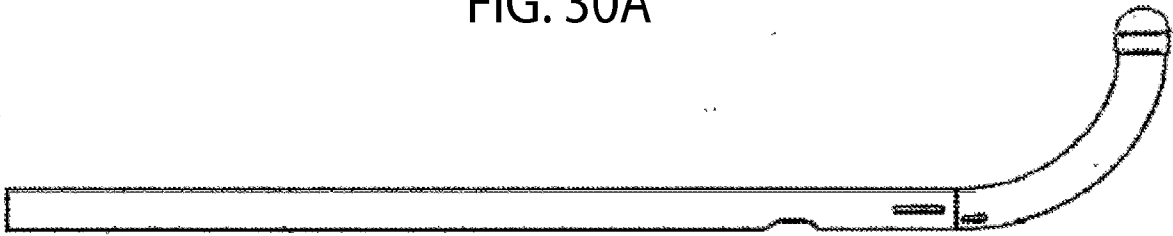

FIG. 30B

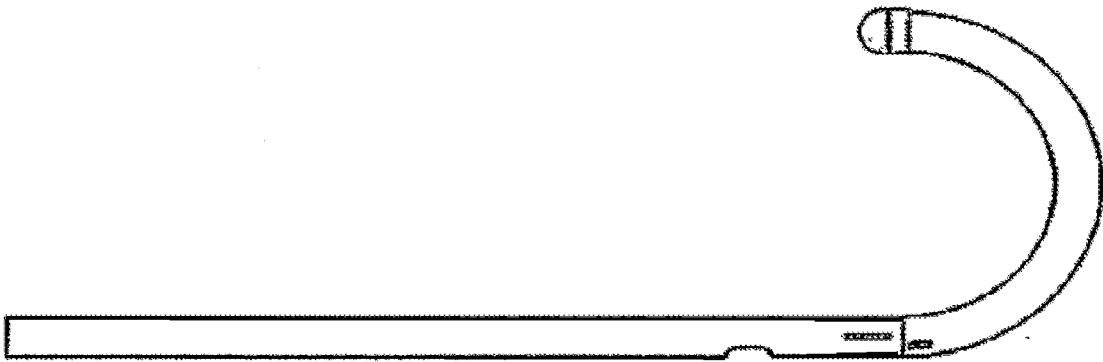

FIG. 30C

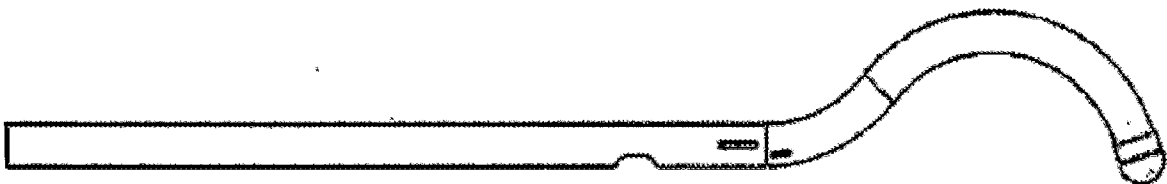

FIG. 30D

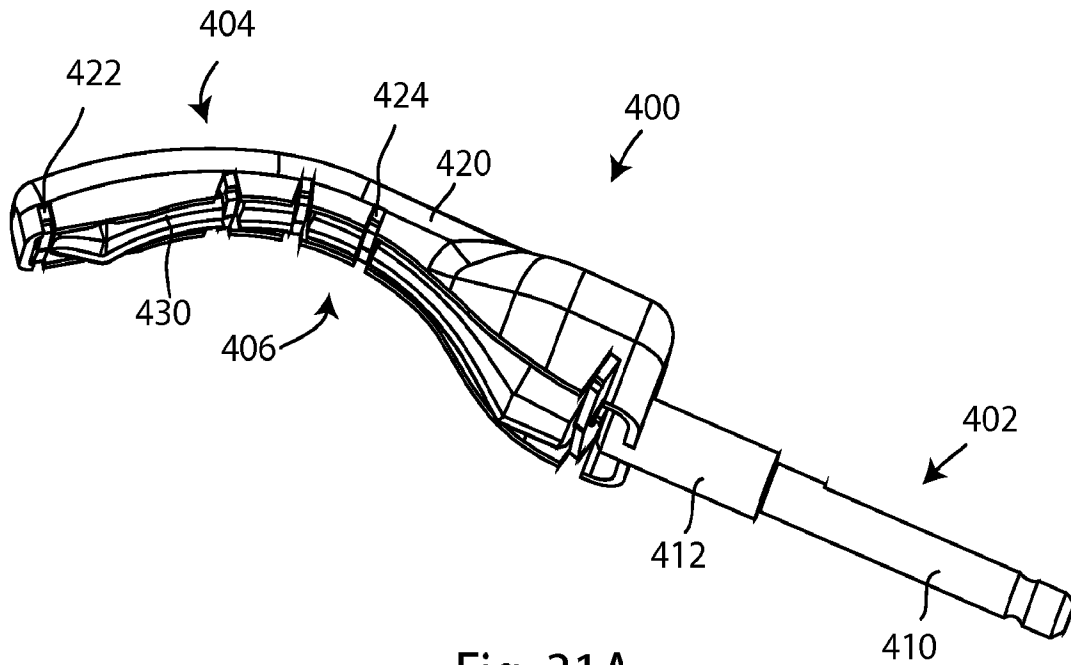

Fig. 31A

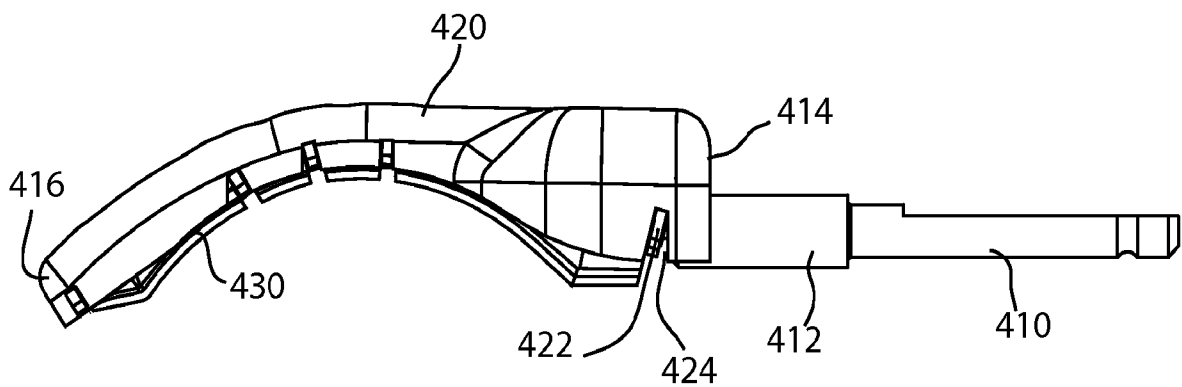

Fig. 31B

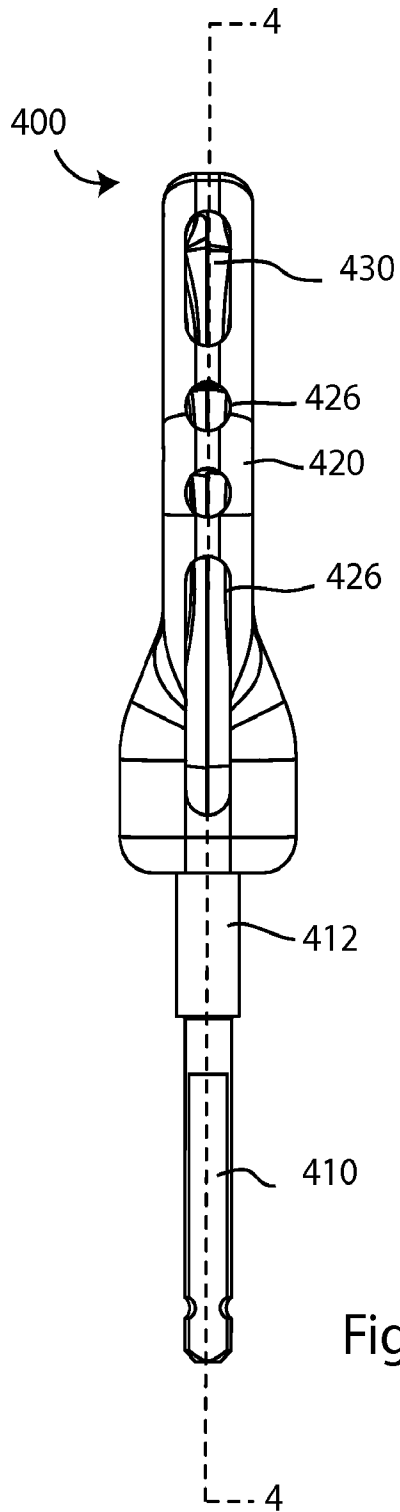

Fig. 32A

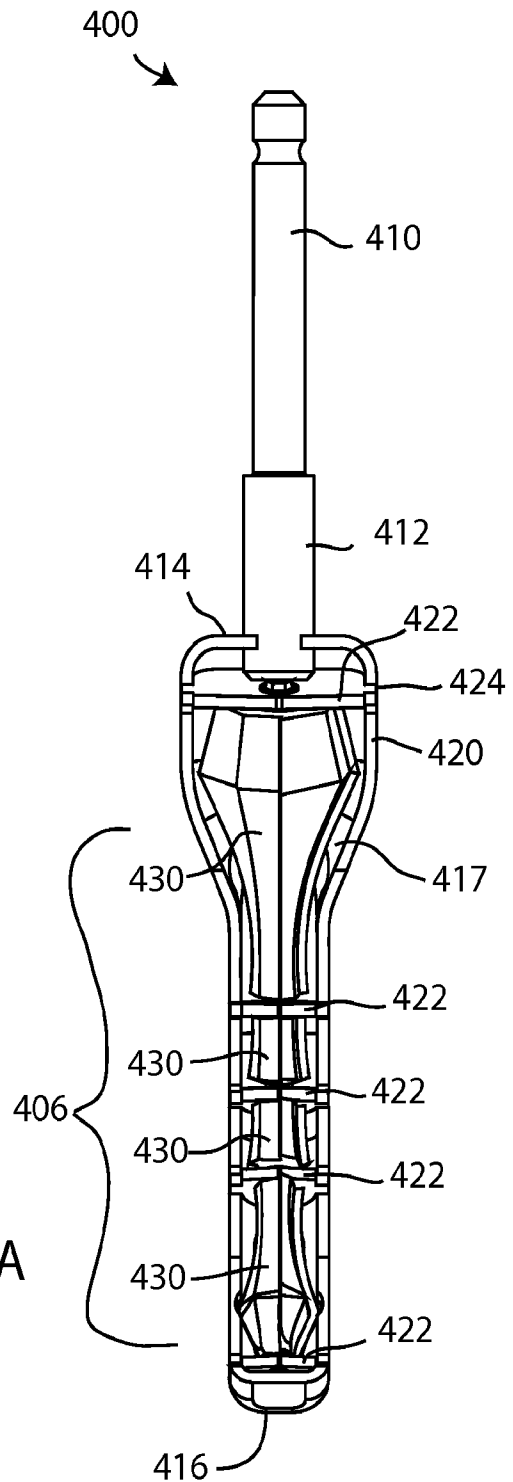

Fig. 32B

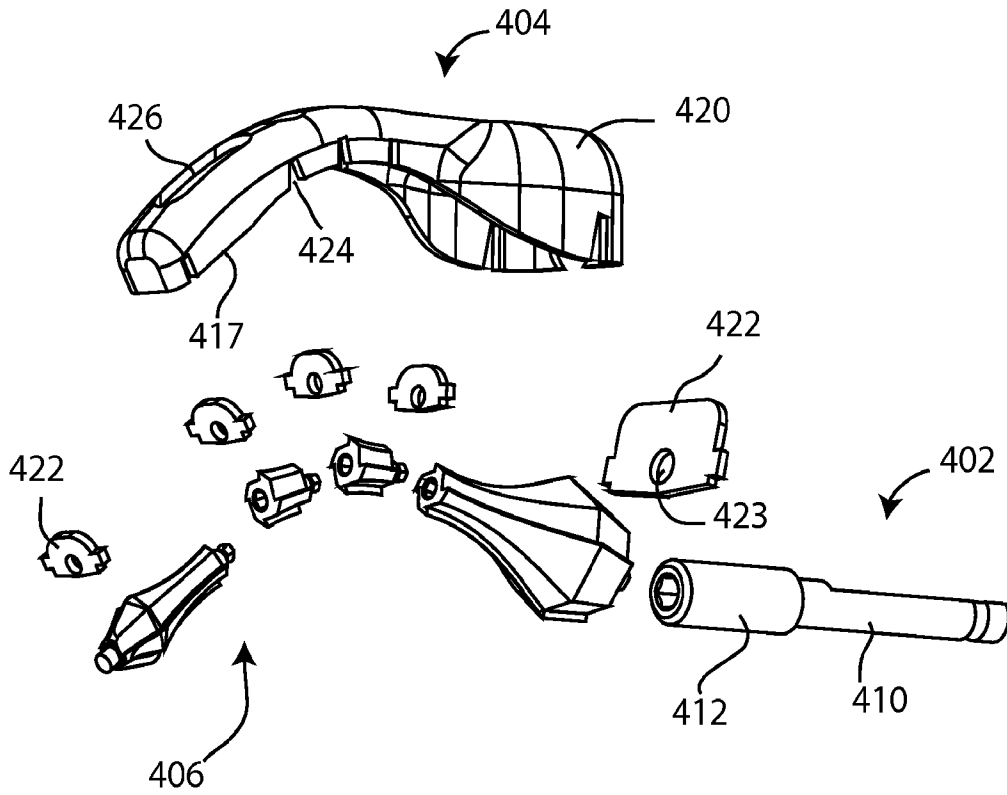

Fig. 33

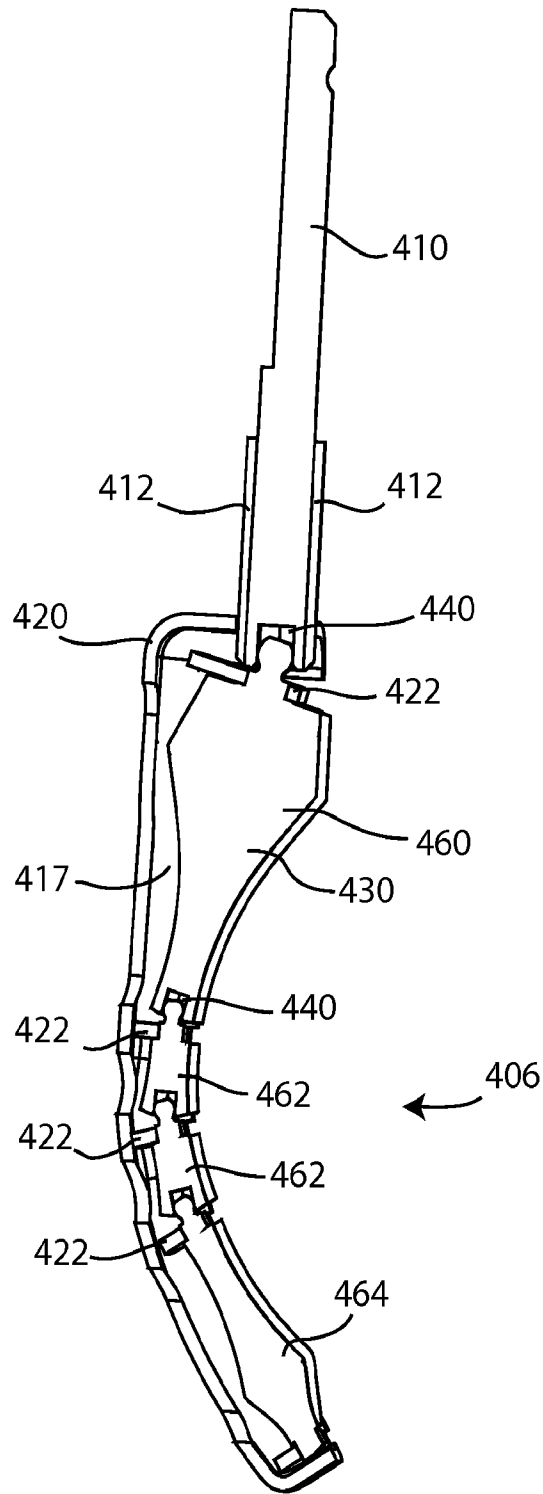
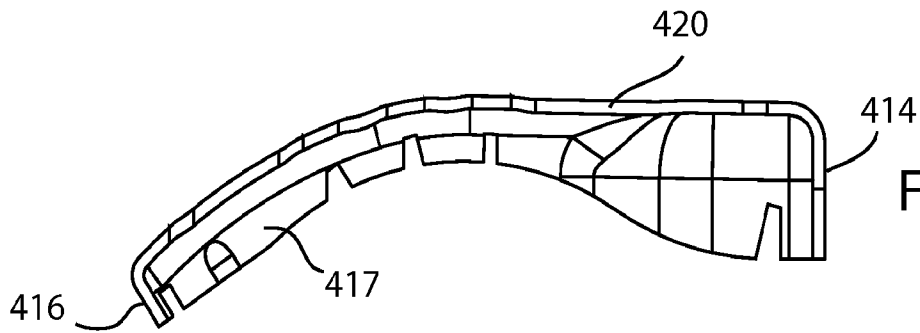
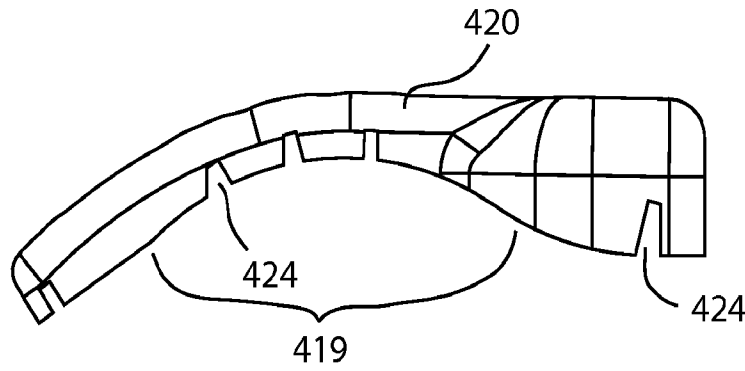
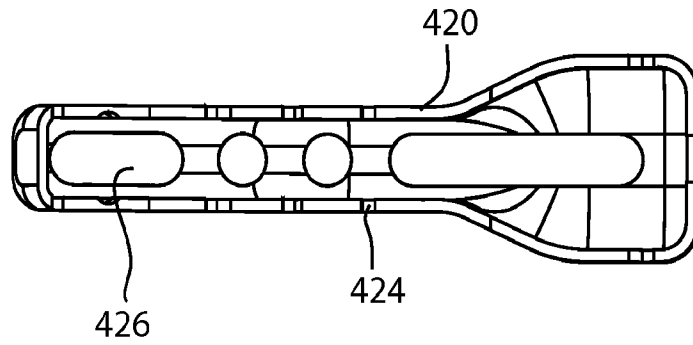
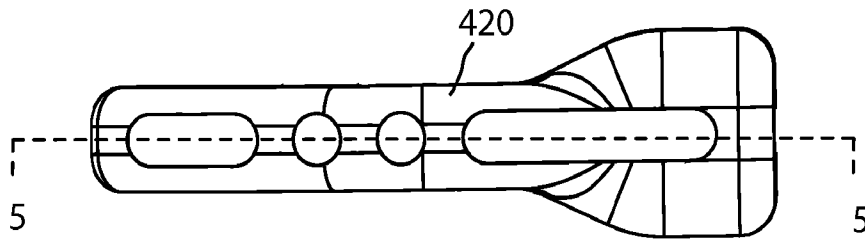

Fig. 34



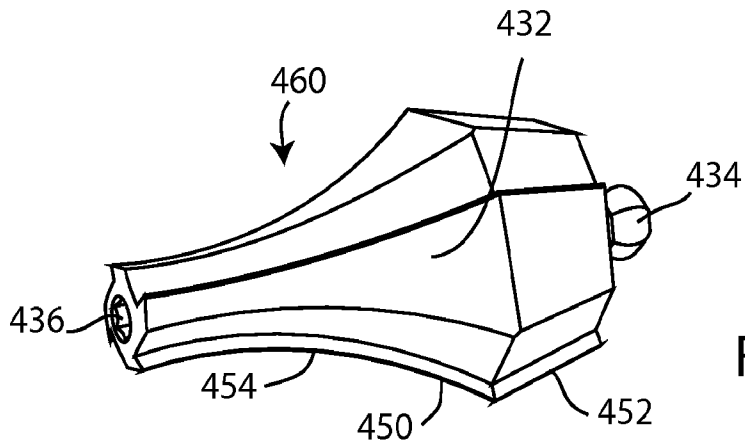

Fig. 36A

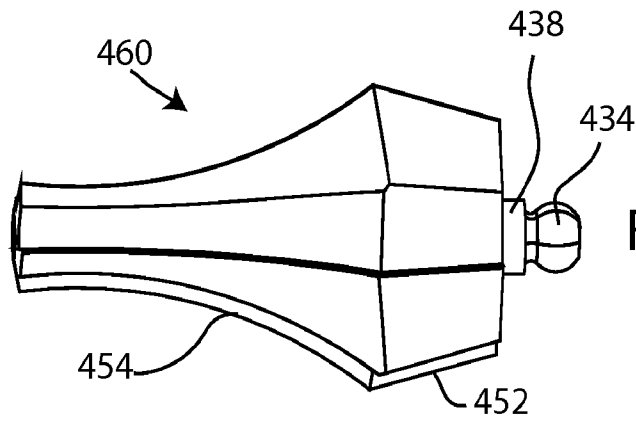

Fig. 36B

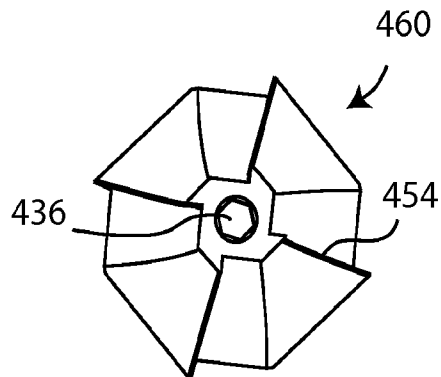

Fig. 36C

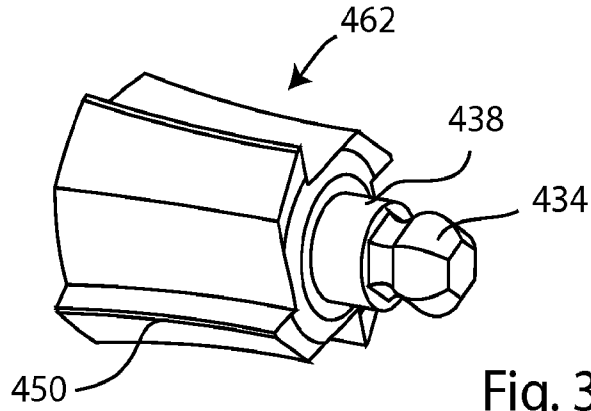

Fig. 37A

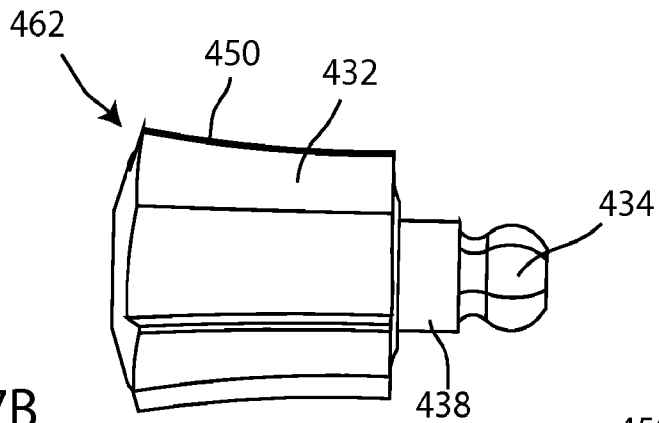

Fig. 37B

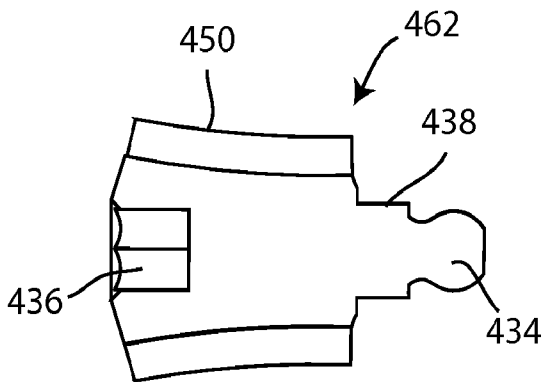

Fig. 37C

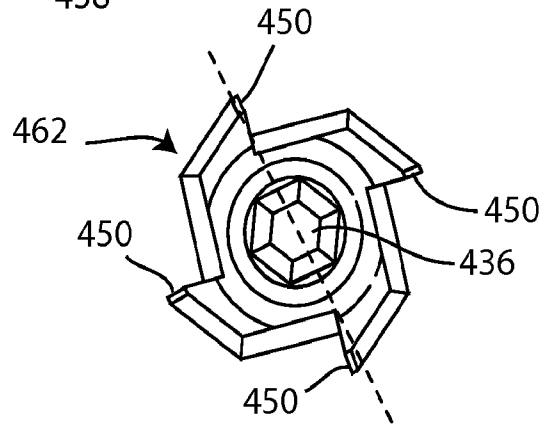

Fig. 37D

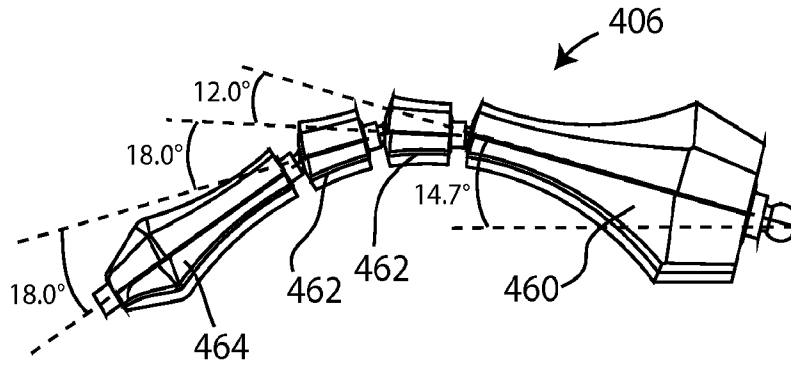

Fig. 38

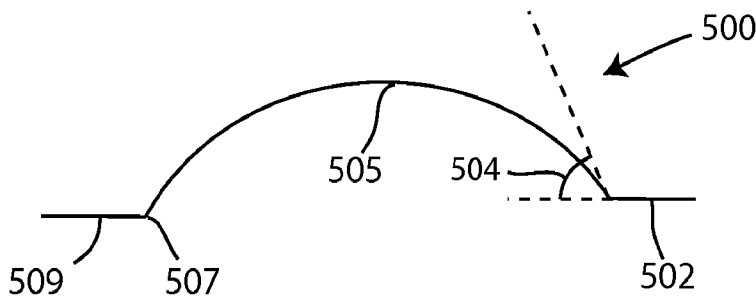

Fig. 39

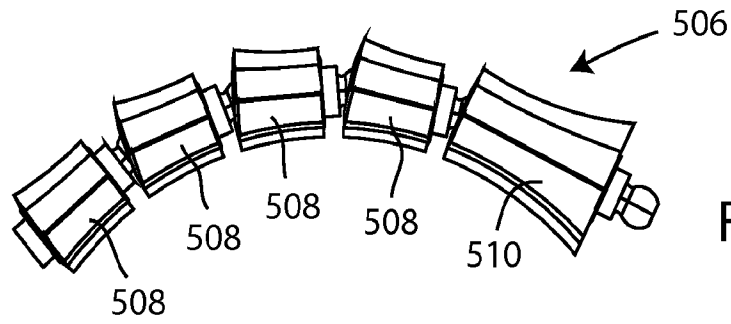

Fig. 40

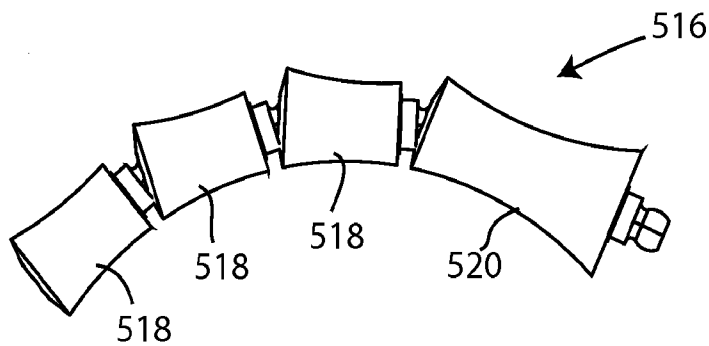

Fig. 41

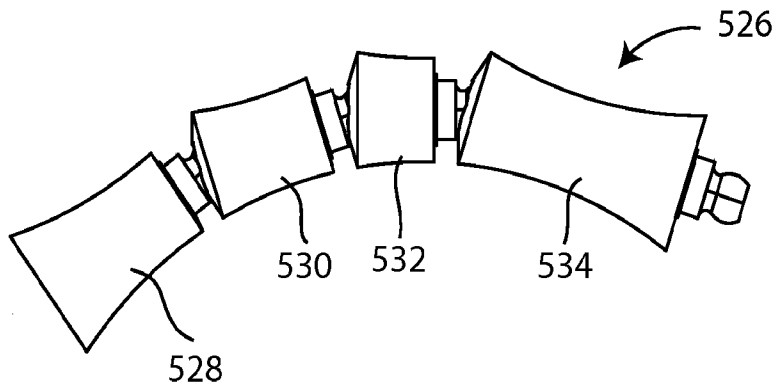

Fig. 42

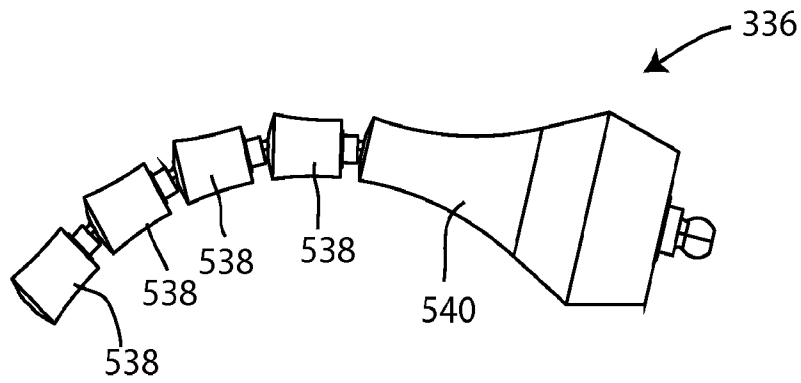

Fig. 43

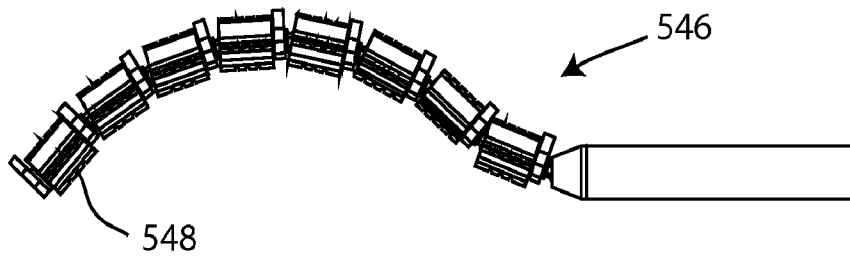

Fig. 44

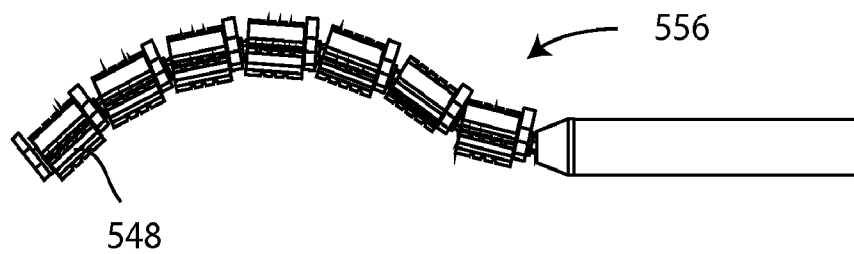

Fig. 45



Fig.46



Fig.47



Fig.48



Fig.49



Fig.50



Fig.51

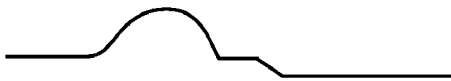

Fig.52



Fig.53

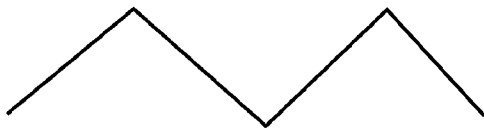

Fig.54



Fig.55

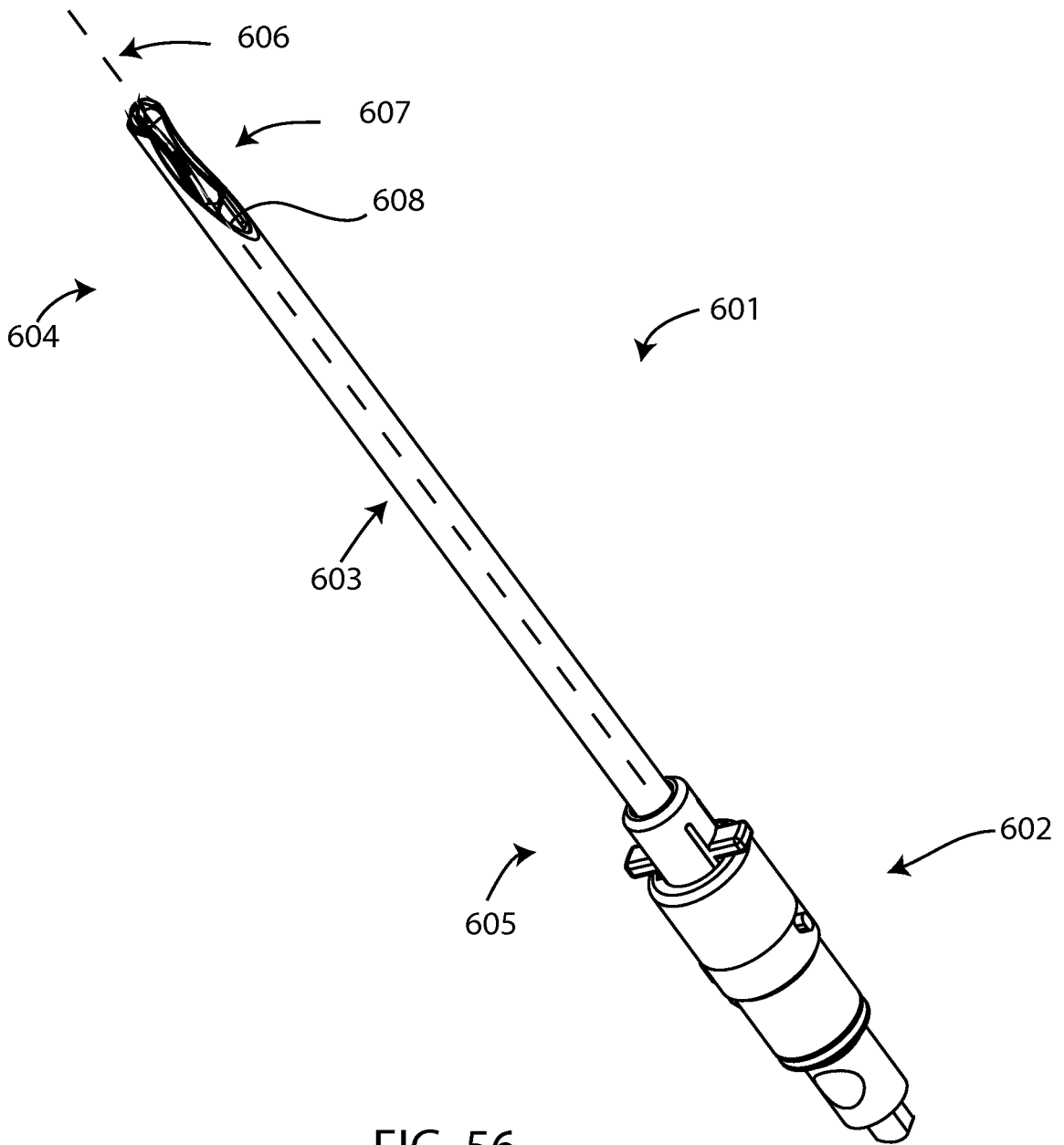
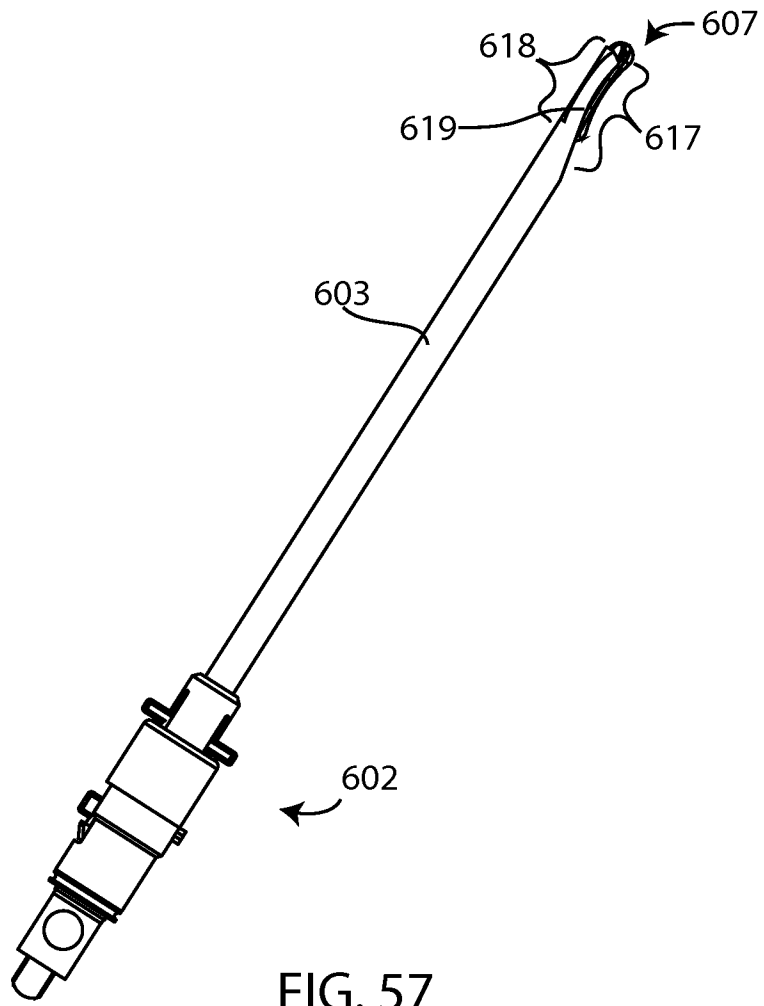

FIG. 56



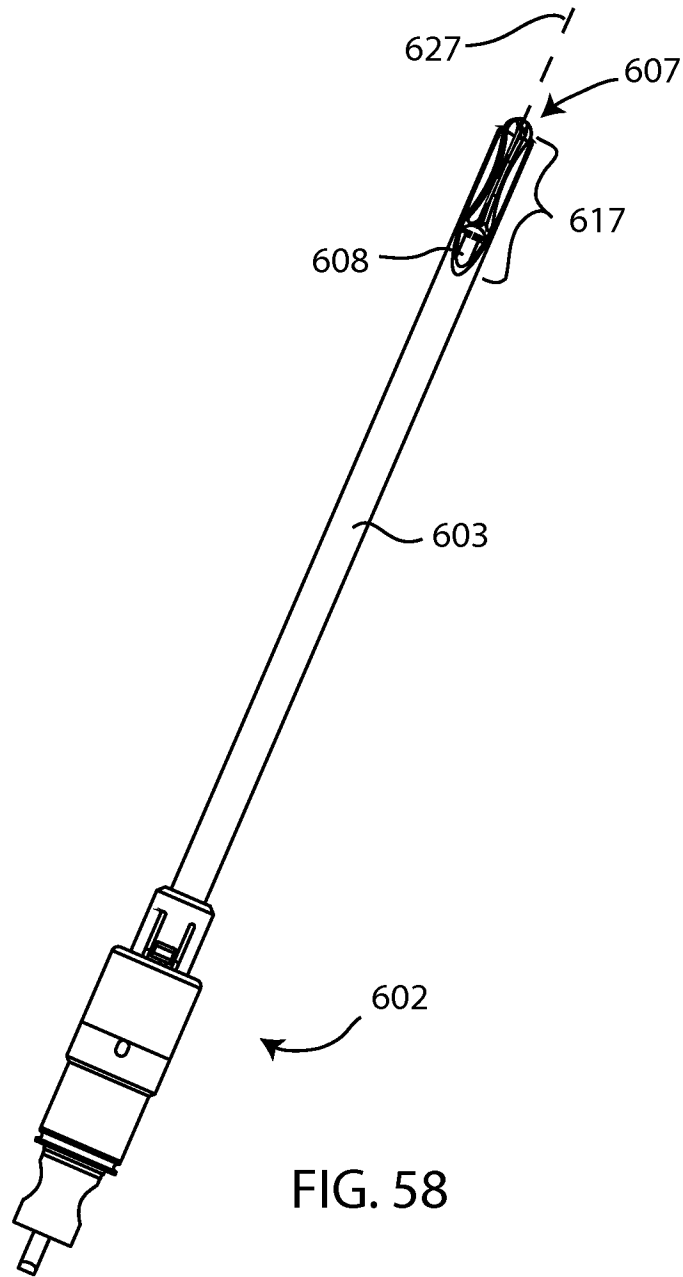

FIG. 58

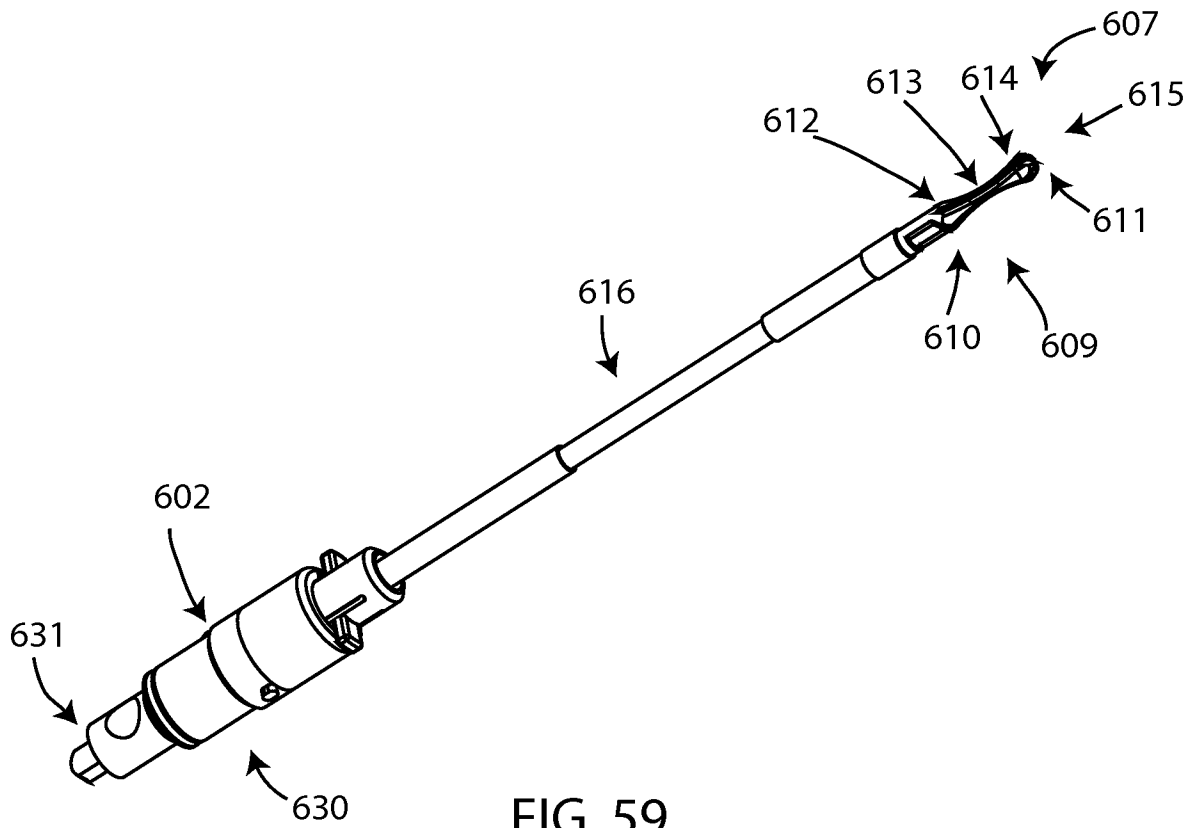
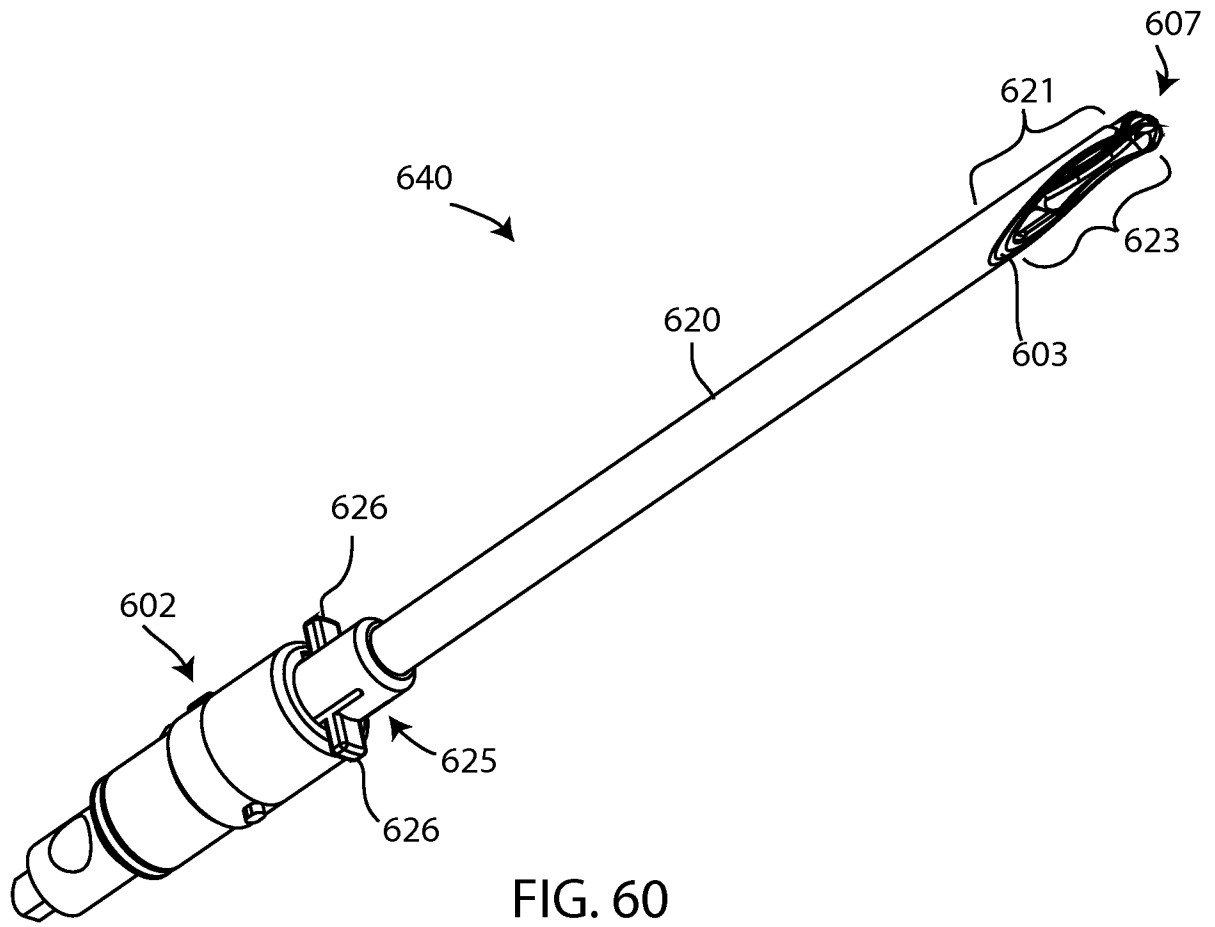

FIG. 59



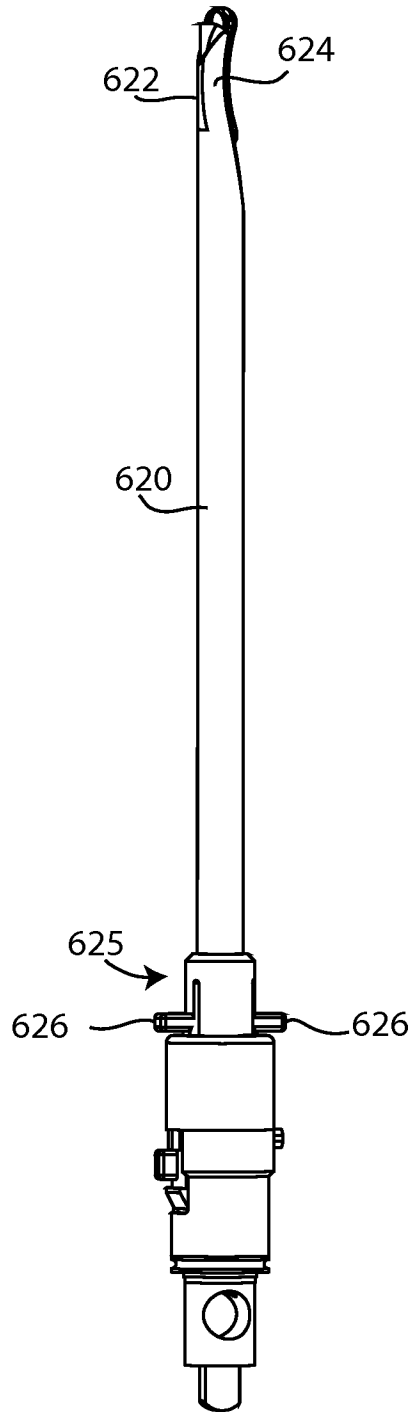

FIG. 61

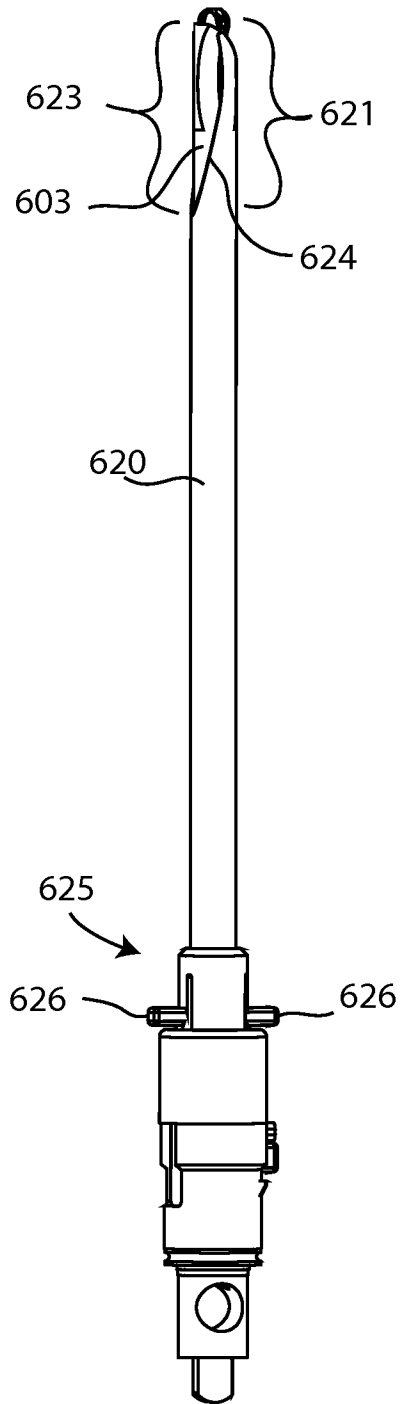

FIG. 62

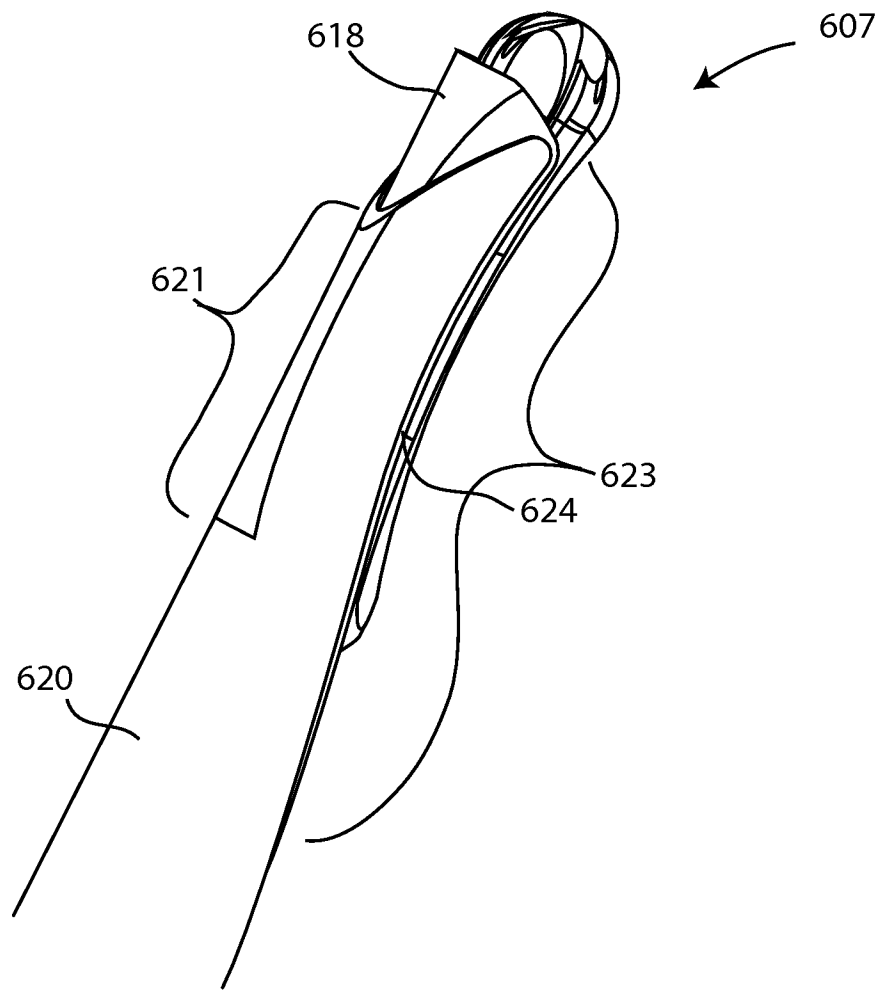

FIG. 63

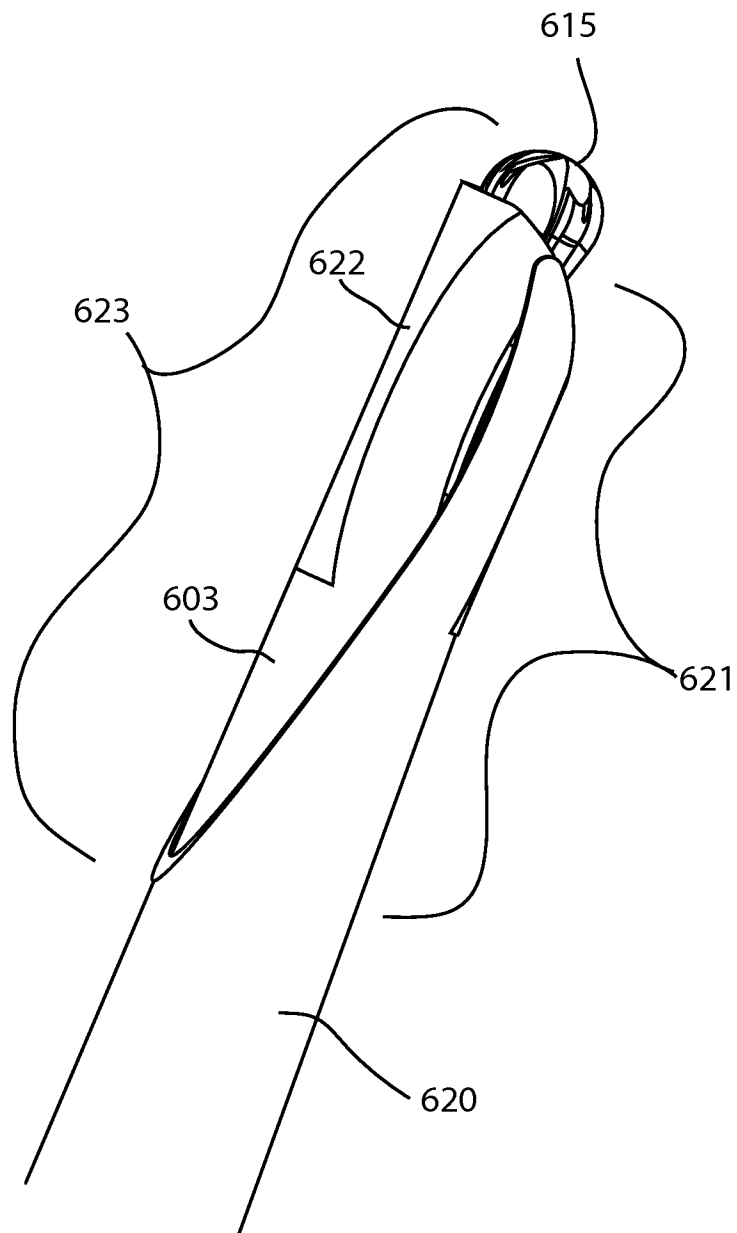

FIG. 64

INTERNATIONAL SEARCH REPORT

International application No PCT/US2013/025414

A. CLASSIFICATION OF SUBJECT MATTER
 INV. A61B17/32 A61B17/16 A61B17/3207
 ADD.

According to International Patent Classification (IPC) or to both national classification and IPC

B. FIELDS SEARCHED

Minimum documentation searched (classification system followed by classification symbols)
 A61F A61B

Documentation searched other than minimum documentation to the extent that such documents are included in the fields searched

Electronic data base consulted during the international search (name of data base and, where practicable, search terms used)

EPO-Internal, WPI Data

C. DOCUMENTS CONSIDERED TO BE RELEVANT

Category*	Citation of document, with indication, where appropriate, of the relevant passages	Relevant to claim No.
X	EP 1 389 458 A1 (NAGASHIMA MEDICAL INSTR CO LTD [JP]) 18 February 2004 (2004-02-18)	1-3, 8, 12, 16
Y	paragraphs [0010] - [0013], [0057] - [0059]; figures 1, 13a, 13b -----	11, 15
X	US 2011/196399 A1 (ROBERTSON GALEN C [US] ET AL) 11 August 2011 (2011-08-11)	13, 14, 16, 17, 19, 20
Y	figures 36, 41-45 paragraphs [0189] - [0194] -----	15
X	US 2010/179557 A1 (HUSTED DANIEL S [US]) 15 July 2010 (2010-07-15) figures 1-6 paragraphs [0023] - [0024], [0032], [0035] - [0036], [0057] - [0058] ----- -/--	16-20

Further documents are listed in the continuation of Box C.

See patent family annex.

* Special categories of cited documents :

"A" document defining the general state of the art which is not considered to be of particular relevance
 "E" earlier application or patent but published on or after the international filing date
 "L" document which may throw doubts on priority claim(s) or which is cited to establish the publication date of another citation or other special reason (as specified)
 "O" document referring to an oral disclosure, use, exhibition or other means
 "P" document published prior to the international filing date but later than the priority date claimed

"T" later document published after the international filing date or priority date and not in conflict with the application but cited to understand the principle or theory underlying the invention

"X" document of particular relevance; the claimed invention cannot be considered novel or cannot be considered to involve an inventive step when the document is taken alone

"Y" document of particular relevance; the claimed invention cannot be considered to involve an inventive step when the document is combined with one or more other such documents, such combination being obvious to a person skilled in the art

"&" document member of the same patent family

Date of the actual completion of the international search

24 April 2013

Date of mailing of the international search report

06/05/2013

Name and mailing address of the ISA/

European Patent Office, P.B. 5818 Patentlaan 2
 NL - 2280 HV Rijswijk
 Tel. (+31-70) 340-2040,
 Fax: (+31-70) 340-3016

Authorized officer

Friedrich, Franz

INTERNATIONAL SEARCH REPORT

International application No

PCT/US2013/025414

C(Continuation). DOCUMENTS CONSIDERED TO BE RELEVANT

Category*	Citation of document, with indication, where appropriate, of the relevant passages	Relevant to claim No.
X	WO 2004/075719 A2 (SENORX INC [US]) 10 September 2004 (2004-09-10) figures 1-12B, 24-30 paragraphs [0001], [0005], [0009] - [0011], [0047] - [0053], [0059] - [0061] -----	13, 16
X	US 5 569 284 A (YOUNG WAYNE P [US] ET AL) 29 October 1996 (1996-10-29) figures 1, 4-6 column 2, line 59 - column 3, line 11 column 3, line 44 - column 5, line 58 -----	13, 16-20
X,P	US 2013/023882 A1 (FABRO MYRA I L [US] ET AL) 24 January 2013 (2013-01-24) figures 4A, 5A, 6A-6L, 11A-11D, 12A-12C paragraphs [0004] - [0005], [0032] - [0040], [0049], [0058], [0062] - [0063] -----	13, 14, 16-19
X	US 2005/203508 A1 (THELEN SARAH L [US] ET AL) 15 September 2005 (2005-09-15) figures 94-103 paragraphs [0309] - [0317] -----	1, 6, 7
Y	US 2011/004215 A1 (BRADLEY JAMES P [US] ET AL) 6 January 2011 (2011-01-06) figures 21, 22, 26 paragraphs [0049], [0050] - [0053] -----	11

INTERNATIONAL SEARCH REPORT

International application No.
PCT/US2013/025414

Box No. II Observations where certain claims were found unsearchable (Continuation of item 2 of first sheet)

This international search report has not been established in respect of certain claims under Article 17(2)(a) for the following reasons:

1. Claims Nos.:
because they relate to subject matter not required to be searched by this Authority, namely:

2. Claims Nos.:
because they relate to parts of the international application that do not comply with the prescribed requirements to such an extent that no meaningful international search can be carried out, specifically:

3. Claims Nos.:
because they are dependent claims and are not drafted in accordance with the second and third sentences of Rule 6.4(a).

Box No. III Observations where unity of invention is lacking (Continuation of item 3 of first sheet)

This International Searching Authority found multiple inventions in this international application, as follows:

see additional sheet

1. As all required additional search fees were timely paid by the applicant, this international search report covers all searchable claims.
2. As all searchable claims could be searched without effort justifying an additional fees, this Authority did not invite payment of additional fees.
3. As only some of the required additional search fees were timely paid by the applicant, this international search report covers only those claims for which fees were paid, specifically claims Nos.:
4. No required additional search fees were timely paid by the applicant. Consequently, this international search report is restricted to the invention first mentioned in the claims; it is covered by claims Nos.:

Remark on Protest

- The additional search fees were accompanied by the applicant's protest and, where applicable, the payment of a protest fee.
- The additional search fees were accompanied by the applicant's protest but the applicable protest fee was not paid within the time limit specified in the invitation.
- No protest accompanied the payment of additional search fees.

This International Searching Authority found multiple (groups of) inventions in this international application, as follows:

1. claims: 1-12

A tissue resection device comprising a rotary cutting member with a concave shape

2. claims: 13-15

A surgical instrument comprising a protective hood to selectively cover or uncover the instrument's end effector

3. claims: 16-20

A tissue resection device comprising a depth stop for controlling the depth of tissue to be removed

INTERNATIONAL SEARCH REPORT

Information on patent family members

International application No PCT/US2013/025414

Patent document cited in search report	Publication date	Patent family member(s)	Publication date
EP 1389458	A1	18-02-2004	EP 1389458 A1 18-02-2004 US 2004153111 A1 05-08-2004 WO 02089722 A1 14-11-2002

US 2011196399	A1	11-08-2011	AU 2011215911 A1 23-08-2012 CA 2789012 A1 18-08-2011 CN 102843979 A 26-12-2012 EP 2533704 A1 19-12-2012 US 2011196399 A1 11-08-2011 WO 2011100323 A1 18-08-2011

US 2010179557	A1	15-07-2010	US 2010179557 A1 15-07-2010 WO 2010083362 A2 22-07-2010

WO 2004075719	A2	10-09-2004	AU 2004216244 A1 10-09-2004 CA 2516663 A1 10-09-2004 EP 1599125 A2 30-11-2005 WO 2004075719 A2 10-09-2004

US 5569284	A	29-10-1996	NONE

US 2013023882	A1	24-01-2013	US 2013023882 A1 24-01-2013 WO 2012112579 A1 23-08-2012

US 2005203508	A1	15-09-2005	NONE

US 2011004215	A1	06-01-2011	EP 2412320 A1 01-02-2012 US 2011004215 A1 06-01-2011
