

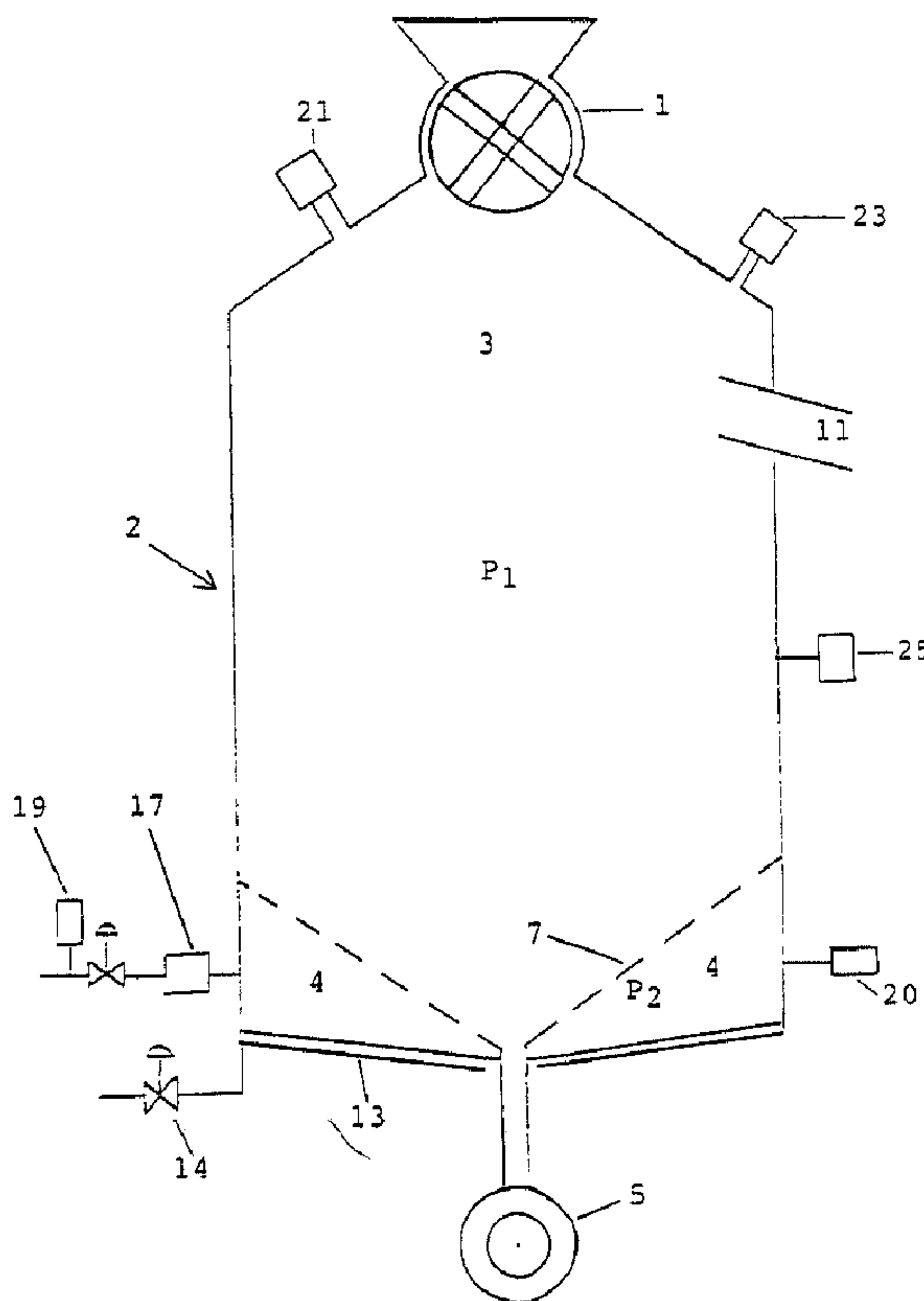

(86) Date de dépôt PCT/PCT Filing Date: 1993/01/19  
 (87) Date publication PCT/PCT Publication Date: 1993/08/05  
 (45) Date de délivrance/Issue Date: 2004/09/21  
 (85) Entrée phase nationale/National Entry: 1994/07/05  
 (86) N° demande PCT/PCT Application No.: BE 1993/000003  
 (87) N° publication PCT/PCT Publication No.: 1993/014651  
 (30) Priorité/Priority: 1992/01/31 (9200108) BE

(51) Cl.Int.<sup>5</sup>/Int.Cl.<sup>5</sup> A23L 3/18, A23B 7/005, A23B 4/005  
 (72) Inventeur/Inventor:  
 THIENPONT, BERNARD, BE  
 (73) Propriétaire/Owner:  
 THIENPONT, BERNARD, BE  
 (74) Agent: SMART & BIGGAR

(54) Titre : METHODE ET DISPOSITIFS DE TRAITEMENT DE PRODUITS ALIMENTAIRES FRAIS  
 (54) Title: METHOD AND DEVICES FOR PROCESSING FRESH FOODSTUFFS



(57) Abrégé/Abstract:

A method for preserving bulk fresh foodstuffs by heat treatment, wherein the foodstuffs are passed through a low-pressure chamber (3) and exposed to a counter-flow of steam which condenses on the foodstuffs and thereby delivers the heat required to heat them.

2127459

2127459

**(57) Abstract**

A method for preserving bulk fresh foodstuffs by heat treatment, wherein the foodstuffs are passed through a low-pressure chamber (3) and exposed to a counter-flow of steam which condenses on the foodstuffs and thereby delivers the heat required to heat them.

METHOD AND DEVICES FOR PROCESSING FRESH FOODSTUFFS

Subject of the invention

The present invention relates to a method for processing fresh foodstuffs in large quantities and in bulk, such as fruit and vegetables but also other types of foodstuffs such as pasta, fish, meat, etc. in order to allow them to be preserved for a long period of time whilst keeping their organoleptic characteristics. The invention also extends to devices for implementing this method.

Technological background

The normal techniques of preservation by pasteurization or sterilization aim to make products preservable for a long period of time whilst trying to keep their taste and their appearance.

The main difficulty resides in the fact that the products are normally heated by direct contact, that is to say by conduction or by convection and most often at high temperatures and for long periods of time, which makes the product lose some of its organoleptic and physico-chemical properties.

By way of example, let us consider the particular case of techniques for preserving fruit. For most known techniques relating to the preservation of fruit, the heat treatment of the pieces of fruit produces a purée or stewed fruit which is not suitable for most current industrial or household uses, in particular for cake making.

Various methods for preserving or cooking foodstuffs, which attempt to remedy this problem are known in the state of the art.

In particular, document FR-A-2,635,167 describes

an apparatus for steam treatment of products in a pressurized or vacuum chamber. Although the products are apparently treated in bulk, it seems to be necessary to arrange them, for example, on trays or trolleys in order to carry out the processing in the apparatus.

Furthermore, this processing can in no way be carried out continuously or semicontinuously. In fact, the apparatus has to be stopped in order to introduce the foodstuffs into the pressurized or vacuum chamber.

Document EP-A-0,006,369 describes a method for continuous heat treatment of unpackaged or packaged bulk products in a casing in which a vacuum is set up; this vacuum is then broken by an external supply of steam. This step has the consequence of pressurizing the casing.

Document CA-A-975,976 describes a method for cooking foodstuffs according to which water is heated to boiling in an enclosed container, and air and some of the steam created in this container are expelled so as to obtain a partial vacuum therein, the cooking is carried out under partial vacuum and this partial vacuum is terminated before removing the foodstuffs from the container. This method which is described obviously does not allow continuous or semicontinuous treatment. Again, the machine should be completely stopped before extracting the foodstuffs.

Document US-A-4,543,283 describes an apparatus and a method which are intended for heating and cooling foodstuffs continuously, in which the steam treatment container is under pressure.

Objects of the invention

The invention aims to provide a method for preservation of fresh foodstuffs which avoids the draw-

75656-2

- 3 -

backs of solutions of the state of the art and more particularly aims to develop a processing method which provides better guarantees of preserving the organoleptic and physio-chemical characteristics of the treated product.

5           In particular, it is desired to obtain a method which operates continuously or semicontinuously and which allows the foodstuffs treated to be packaged directly on leaving the treatment device.

10           The method according to the invention is more precisely intended for what is termed "aseptic filler" or "hot filler" techniques, which may be expressed in French as techniques of aseptic filling or self-pasteurization, without cooling.

15           The invention also relates to devices (installations) for implementing the said method.

#### Summary of the Invention

20           The present invention provides a device for preservation of bulk fresh foodstuffs by heat treatment, characterized in that said device comprises: a vessel (2) in which the foodstuffs are introduced, after which the foodstuffs undergo a movement within said vessel, and wherein the foodstuffs are heated by the condensation of steam moving in a direction opposite to the movement of the foodstuffs, said vessel (2) comprising: an upper chamber  
25 (3), which is connected via a condenser (11) to a vacuum pump (9), and in which a constant pressure ( $P_1$ ) prevails which is lower than the atmospheric pressure, one or more lower housing (4) separated from the upper chamber (3) by perforated grids (7) and in which a second pressure ( $P_2$ )  
30 prevails which is higher than the constant pressure ( $P_1$ ) prevailing in the upper chamber (3), and an airlock (1)

75656-2

- 4 -

intended to introduce the foodstuffs into the vessel (2) and a positive displacement pump (5) which removes the product from the vessel (2).

The present invention also provides a method for  
5 preservation of bulk fresh foodstuffs by heat treatment, characterized in that: the foodstuffs are introduced under reduced pressure in the vessel (2) of a device as aforesaid, the foodstuffs undergo a movement through said device, the  
10 foodstuffs are subjected to a flow of steam in a direction opposite to that of the movement of the foodstuffs, the steam condensing on the foodstuffs while thus providing said foodstuffs with a part of the heat needed for heating said  
15 foodstuffs.

According to the present invention, the heat can  
15 be transmitted to the product in its bulk, that is to say without needing to agitate or manipulate the product and therefore without it becoming damaged.

The processing of foodstuffs according to the present invention can be carried out in a semicontinuous  
20 mode, and also with a continuous mode, advantageously in a very short space of time of the order of 5 to 6 minutes.

Furthermore, the method according to the present invention is carried out without an external supply of steam being necessary.

#### 25 Brief Description of the Figures

- Figure 1 represents a diagrammatic view of the device according to the invention, allowing implementation of the method.

- Figure 2 represents a detailed view of the  
30 reduced-pressure vessel according to Figure 1.

75656-2

- 4a -

- Figure 3 represents a diagrammatic view of another preferred device of the invention, corresponding to an alternative embodiment of the method.

- Figure 4 represents a diagrammatic view of  
5 another preferred device of the invention, corresponding to another alternative embodiment of the method.

The same reference numbers are used in the various figures to represent identical or similar elements.

Detailed Description of Several Preferred Embodiments of

the invention

As is shown by Figures 1 and 2, the foodstuffs, for example fruit, are introduced into a vessel which is under reduced pressure with respect to atmospheric pressure and given the general reference 2, via an airlock 1 which operates by compartmentalization.

In preference, this airlock 1 which is intended to introduce the foodstuffs into the vessel 2 is equipped with a variable-speed gear and a frequency converter which is coupled to a positive displacement pump 5 arranged at the exit of the vessel 2 and which removes the product therefrom.

The reduced-pressure vessel 2 is essentially composed of an upper chamber 3 and one or more lower housings 4 separated from the enclosure 3 by perforated grids 7.

The chamber 3 is connected via a condenser 11 to a vacuum pump 9.

This condenser 11 may operate in various modes. For example, the condensation may be obtained by preferably spraying droplets of water into the condenser, or a cold water pipeline is alternatively directly fitted to the condenser and connected to a vacuum pump, preferably a stainless steel ring water pump.

The operation of the airlock 1 necessarily brings air in through the airlock itself and consequently causes loss of pressure reduction. The pump must therefore be capable of continuously compensating for this pressure reduction loss so as to obtain a constant pressure  $P_1$  (less than atmospheric pressure  $P_a$ ) in the chamber 3 when the apparatus is operating.

The covering liquid coming from a tank 15 is

introduced into the reduced-pressure vessel 2 via a flowmeter 17 which regulates the covering liquid supply using a differential-pressure valve 19.

5 More precisely, this covering liquid which is intended for filling the preserving containers (can or bag) during the covering liquid addition stage, is introduced into the housing or housings 4 arranged between the bottom of the vessel 2 and the perforated plates 7. This covering liquid is heated via a double  
10 wall 13 which is itself heated by circulation of steam coming from an external circuit 14.

Other heating means are obviously not precluded.

Consequently, in the housing or housings 4 bounded by the perforated plates 7, a pressure  $P_2$   
15 prevails which is greater than  $P_1$  prevailing in the upper chamber 3, that is to say that the reduced pressure prevailing in the housing 4 is less strong than that in the chamber 3.

Because of this, there is a movement of steam  
20 which is constantly formed from the covering liquid coming from the housing 4 towards the upper chamber 3 through the perforated plates 7. This steam condenses upon contact with the foodstuff which is at a lower temperature, thus providing it with the heat supply  
25 necessary for pasteurizing the foodstuff.

Furthermore, foodstuffs which lie in the uppermost layers of the upper chamber 3 have the oxygen present in their tissues removed because of the reduced pressure  $P_1$  prevailing in this chamber.

30 As the foodstuff descends in the reduced-pressure vessel 2, it is heated constantly, layer by layer, by condensation of steam.

At a determined level, the foodstuffs comes into contact with the covering liquid and is sucked up by the positive displacement pump 5 and then leaves the reduced-pressure vessel 2. This prevents a "floating" during the suction on the foodstuff with the covering liquid and perfect mixing of the pieces of foodstuff such as fruit with the covering liquid thereby is obtained.

The product is then pumped towards a scraped-surface exchanger 35 before reaching a "holding" treatment unit 37 where the sterilization is carried out and a cooling unit, not represented, before aseptic filling of, for example, bags.

Any other kind of heat exchanger can be used instead of a scraped-surface exchanger.

The device also comprises several sensors or detectors which are intended to monitor its operation.

In the upper part of the reduced-pressure vessel 2, an electronic pressure detector 23 has been arranged, together with a safety valve 21 which allows removal of the excess steam when an excessively high overpressure peak has been reached.

In preference, this detector 23 will directly control the supply of steam in the external circuit 14 which heats the double wall 13, this being as a function of data additionally supplied by a temperature detector 25.

It is also possible to provide a safety detector 20 which monitors the presence of covering liquid on the double wall 13.

According to a second preferred embodiment of the present invention, foodstuffs having a pH greater than 4 such as meat, vegetables, fish, etc., can be treated in

a device described in Figures 3 and 4.

In this case, the sterilization temperature is greater than 100°C, and, as represented in Figure 3, the foodstuffs are sucked up upon leaving the reduced-  
5 pressure vessel 2 by a positive displacement pump 5 before being introduced into a second chamber 27 which is under pressure. The pressure in this chamber is higher in the lower part than in the upper part. This chamber is also heated by means of a double wall 24 which is itself  
10 heated using steam coming from the external circuit 14. Temperatures greater than 110°C are easily achieved in this way.

The foodstuffs are then sucked up by a steam barrier pump 33 located below the pressurized chamber 27  
15 and are conveyed to the treatment unit 37 and the cooling stage 39 before aseptic filling is carried out.

This arrangement is preferably used for foodstuffs which have a sterilization temperature lying between 100 and 115°C.

20 For foodstuffs requiring a higher temperature (greater than 115°C), the pump 33 will preferably be placed between various cooling stages 39 and consequently at a location where the temperature has already decreased, for example reached about 100°C (see Figure 4).

25 The main advantage of this arrangement is that the product is no longer as decomposable and therefore vulnerable during the pumping by the pump 33. In this case, it should be noted that it is not necessary for the  
30 pump 33 to operate synchronously with the positive displacement pump 5.

75656-2

- 9 -

CLAIMS:

1. Device for preservation of bulk fresh foodstuffs by heat treatment, characterized in that said device comprises:
- 5 - a vessel (2) in which the foodstuffs are introduced, after which the foodstuffs undergo a movement within said vessel, and wherein the foodstuffs are heated by the condensation of steam moving in a direction opposite to the movement of the foodstuffs, said vessel (2) comprising:
- 10 - an upper chamber (3), which is connected via a condenser (11) to a vacuum pump (9), and in which a constant pressure ( $P_1$ ) prevails which is lower than the atmospheric pressure,
- one or more lower housing (4) separated from  
15 the upper chamber (3) by perforated grids (7) and in which a second pressure ( $P_2$ ) prevails which is higher than the constant pressure ( $P_1$ ) prevailing in the upper chamber (3), and
- an airlock (1) intended to introduce the foodstuffs into  
20 the vessel (2) and
- a positive displacement pump (5) which removes the product from the vessel (2).
2. Device according to claim 1, characterized in that the device further comprises:
- 25 - a tank (15) comprising a covering liquid,
- a flowmeter (17) through which the covering liquid coming from the tank (15) is introduced into said one or more lower housing(s) (4) arranged between the bottom of the vessel (2) and the perforated plates (7).

75656-2

- 10 -

3. Device according to claim 2, characterized in that said vessel (2) comprises a double wall (13) and in that said device comprises an external circuit (14), the covering liquid being heated via said double wall (13) which is  
5 itself heated by a circulation of steam coming from the external circuit (14).

4. Device according to claim 1, 2 or 3, characterized in that the device also comprises sensors or detectors (20, 21, 23 and 29) which monitor the operation of the system.

10 5. Device according to claim 1, 2 or 3, characterized in that the device comprises, following the vessel (2) and the positive displacement pump (5), a pressurized chamber (27).

15 6. Device according to claim 5, characterized in that the device comprises a second pump (33) which sucks the product out of the pressurized chamber (27).

7. Device according to claim 6, characterized in that said device comprises a cooling unit (35), comprising two cooling stages, and in that said second pump (33) is  
20 arranged between the two cooling stages of the cooling unit (35).

8. Device according to claim 6, characterized in that said second pump (33) is located after the pressurized chamber (27) and before the cooling unit (35).

25 9. Method for preservation of bulk fresh foodstuffs by heat treatment, characterized in that:

- the foodstuffs are introduced under reduced pressure in the vessel (2) of a device according to any of the claims 1 to 8,

75656-2

- 11 -

- the foodstuffs undergo a movement through said device,
- the foodstuffs are subjected to a flow of steam in a direction opposite to that of the movement of the foodstuffs, the steam condensing on the foodstuffs while  
5 thus providing said foodstuffs with a part of the heat needed for heating said foodstuffs.

10. Method according to claim 9, characterized in that the method is in the form of a semicontinuous or continuous method.

- 10 11. Method according to claim 9 or 10, characterized in that the method is carried out without external supply of steam, the steam being generated from the water released from the foodstuffs and from the covering liquid necessary for aseptic filling.

SMART & BIGGAR

OTTAWA, CANADA

PATENT AGENTS

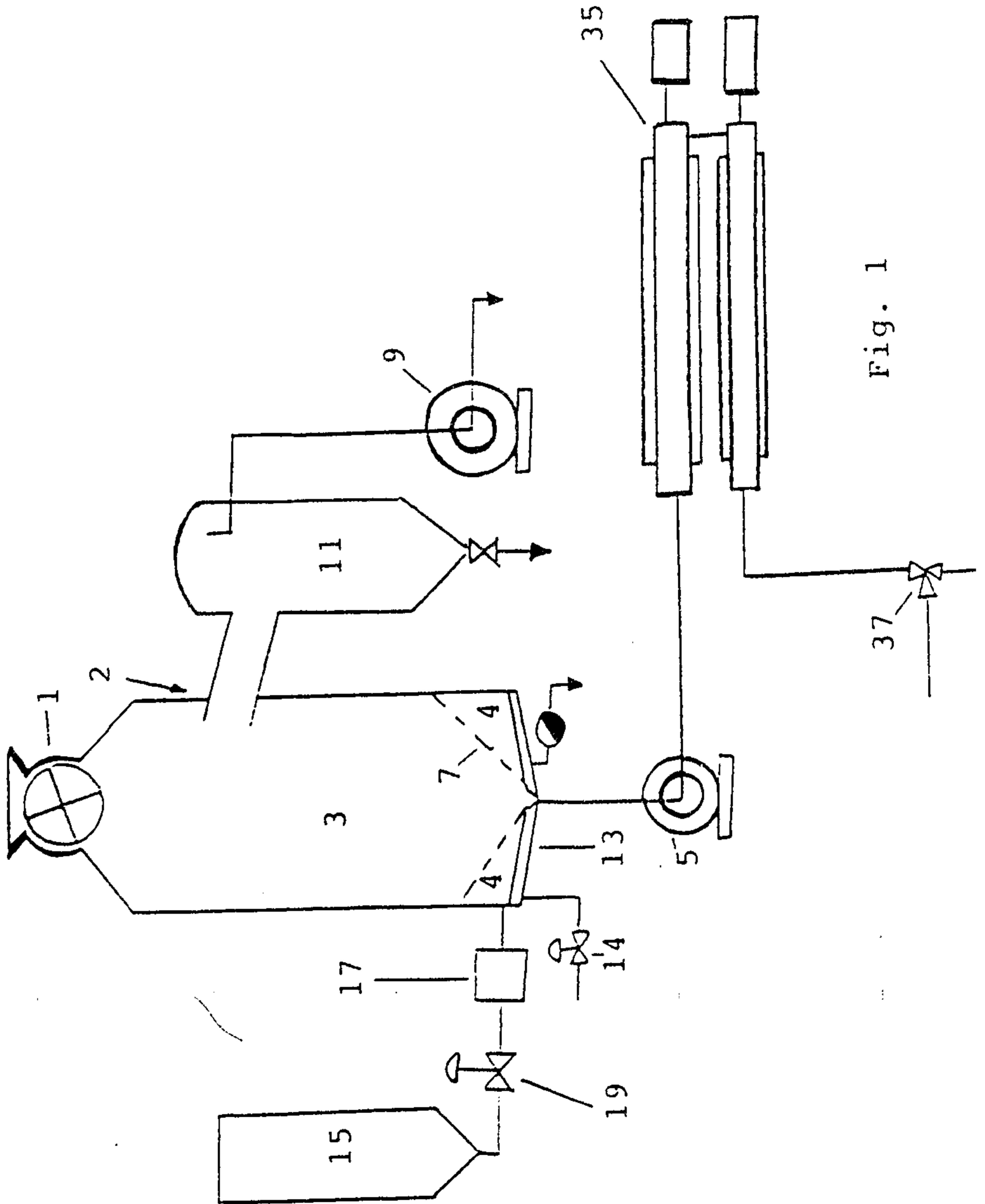

Fig. 1

*Patented by  
Smart & Biggs*

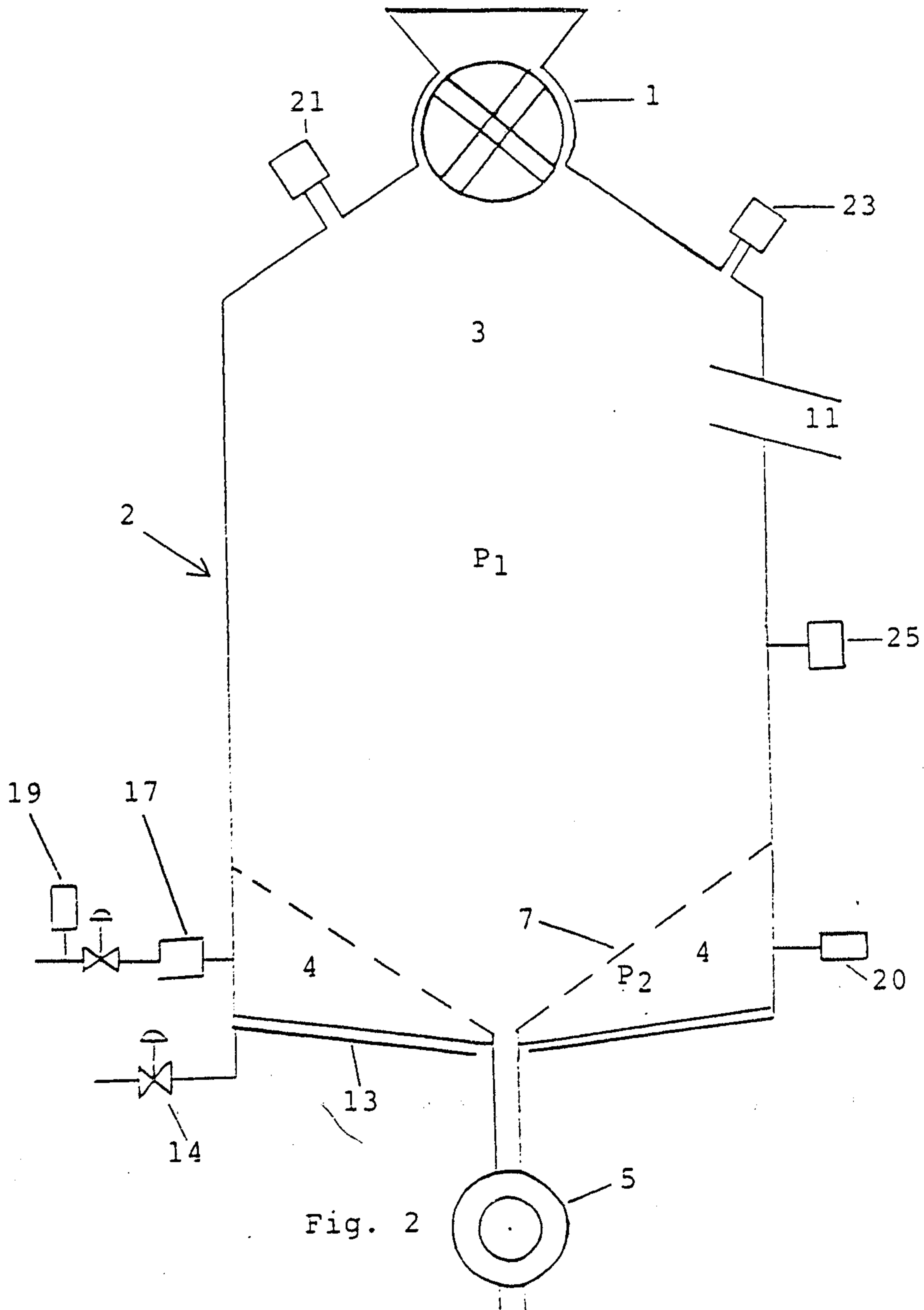

Fig. 2

2127459

3/4

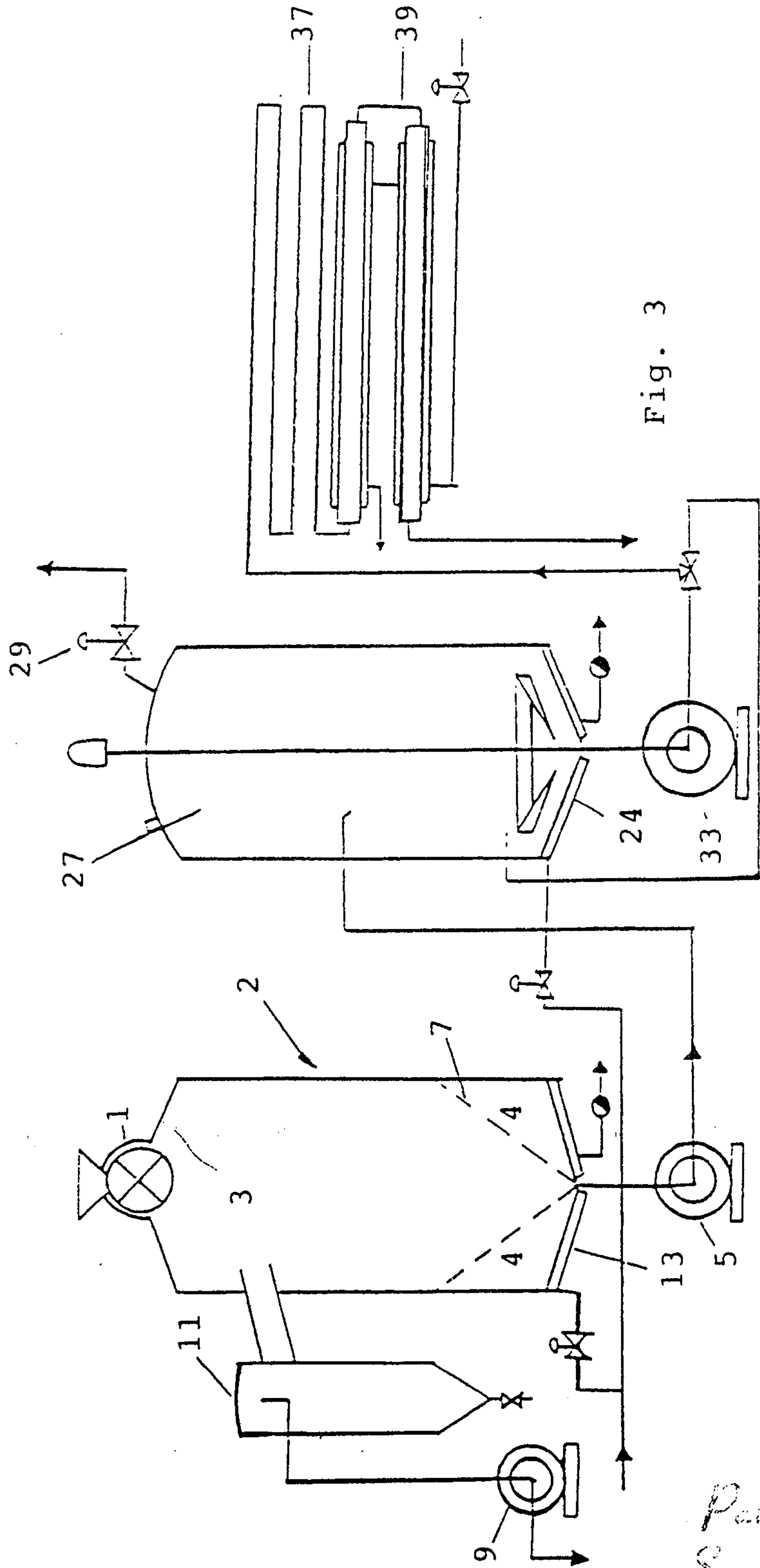

Fig. 3

Patent Agents  
Smart & Big...



