

(19) World Intellectual Property
Organization
International Bureau



(43) International Publication Date
15 December 2005 (15.12.2005)

PCT

(10) International Publication Number
WO 2005/119321 A1

- (51) International Patent Classification⁷: **G02B 6/44**
- (21) International Application Number:
PCT/US2004/022237
- (22) International Filing Date: 9 July 2004 (09.07.2004)
- (25) Filing Language: English
- (26) Publication Language: English
- (30) Priority Data:
10/847,807 18 May 2004 (18.05.2004) US
- (71) Applicant (for all designated States except US): **CORNING CABLE SYSTEMS LLC** [US/US]; 800 17th Street, NW, Post Office Box 489, Hickory, NC 28603 (US).
- (72) Inventors; and
(75) Inventors/Applicants (for US only): **PARSONS, Alan, T.** [US/US]; 2708 Touchstone Circle, Newton, NC 28658 (US). **GREENWOOD, Jody, L.** [US/US]; 3984 Seaver Court, Hickory, NC 28602 (US). **TEMPLE, Kenneth, D., Jr.** [US/US]; 3000 Sandy Ford Road, Newton, NC 28658 (US). **LAIL, Jason, C.** [US/JP]; Royal Haitsue Kakegawa #9-1, 436-0029 (JP).
- (74) Agent: **CARROLL, Michael, E., Jr.**; 800 17th Street, NW, Post Office Box 489, Hickory, NC 28603 (US).
- (81) Designated States (unless otherwise indicated, for every kind of national protection available): AE, AG, AL, AM, AT, AU, AZ, BA, BB, BG, BR, BW, BY, BZ, CA, CH, CN, CO, CR, CU, CZ, DE, DK, DM, DZ, EC, EE, EG, ES, FI, GB, GD, GE, GH, GM, HR, HU, ID, IL, IN, IS, JP, KE, KG, KP, KR, KZ, LC, LK, LR, LS, LT, LU, LV, MA, MD, MG, MK, MN, MW, MX, MZ, NA, NI, NO, NZ, OM, PG, PH, PL, PT, RO, RU, SC, SD, SE, SG, SK, SL, SY, TJ, TM, TN, TR, TT, TZ, UA, UG, US, UZ, VC, VN, YU, ZA, ZM, ZW.
- (84) Designated States (unless otherwise indicated, for every kind of regional protection available): ARIPO (BW, GH, GM, KE, LS, MW, MZ, NA, SD, SL, SZ, TZ, UG, ZM, ZW), Eurasian (AM, AZ, BY, KG, KZ, MD, RU, TJ, TM), European (AT, BE, BG, CH, CY, CZ, DE, DK, EE, ES, FI, FR, GB, GR, HU, IE, IT, LU, MC, NL, PL, PT, RO, SE, SI, SK, TR), OAPI (BF, BJ, CF, CG, CI, CM, GA, GN, GQ, GW, ML, MR, NE, SN, TD, TG).

Published:
— with international search report

For two-letter codes and other abbreviations, refer to the "Guidance Notes on Codes and Abbreviations" appearing at the beginning of each regular issue of the PCT Gazette.

(54) Title: OPTICAL TUBE ASSEMBLY WITH HAVING A DRY INSERT

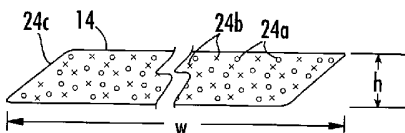

(57) Abstract: An optical tube assembly having at least one optical waveguide, at least one dry insert (14), and a tube (18). The at least one optical waveguide (12) is disposed within the tube (18) and generally surrounds the at least one optical waveguide (12). In one embodiment, the dry insert (14) has a first layer comprising a felt having at least one type of non-continuous filament. The dry insert (14) may also include a plurality of water-swellable filaments (24a). In another embodiment, a dry insert (14) has a first layer (172), a second layer (176), and a plurality of water-swellable filaments (174). The first and second layers (172, 176) are attached together at least along the longitudinal edges thereof, thereby forming at least one compartment (174a) between the first and second layers (172, 176) and the plurality of water-swellable filaments (174) are generally disposed in the at least one compartment (174a). The dry insert (14) also is advantageous in tubeless cable designs.

WO 2005/119321 A1

OPTICAL TUBE ASSEMBLY WITH HAVING A DRY INSERT

RELATED APPLICATIONS

The present application is a Continuation-In-Part (CIP) of U.S. Ser. No. 10/661,204 filed on September 12, 2003, which is a Continuation-In-Part of U.S. Ser. No. 10/326,022 filed on
5 December 19, 2002, the disclosures of which are incorporated herein in their entirety by reference.

FIELD OF THE INVENTION

The present invention relates generally to dry packaging of optical waveguides. More specifically, the invention
10 relates to an optical tube assembly that includes at least one dry insert for protecting at least one optical waveguide.

BACKGROUND OF THE INVENTION

Fiber optic cables include optical waveguides such as optical fibers that transmit optical signals, for example,
15 voice, video, and/or data information. One type of fiber optic cable configuration includes an optical waveguide disposed within a tube, thereby forming a tube assembly. Generally speaking, the tube protects the optical waveguide; however, the optical waveguide must be further protected
20 within the tube. For instance, the optical waveguide should have some relative movement between the optical waveguide and the tube to accommodate bending. On the other hand, the optical waveguide should be adequately coupled with the tube, thereby inhibiting the optical waveguide from being displaced
25 within the tube when, for example, pulling forces are applied to install the cable. Additionally, the tube assembly should inhibit the migration of water therein. Moreover, the tube assembly should be able to operate over a range of temperatures without undue optical performance degradation.

30 Conventional optical tube assemblies meet these requirements by filling the tube with a thixotropic material such as grease. Thixotropic materials generally allow for adequate movement between the optical waveguide and the tube,

cushioning, and coupling of the optical waveguide. Additionally, thixotropic materials are effective for blocking the migration of water within the tube. However, the thixotropic material must be cleaned from the optical waveguide before connectorization of the same. Cleaning the thixotropic material from the optical waveguide is a messy and time-consuming process. Moreover, the viscosity of thixotropic materials is generally temperature dependent. Due to changing viscosity, the thixotropic materials can drip from an end of the tube at relatively high temperatures and the thixotropic materials may cause optical attenuation at relatively low temperatures.

Cable designs have attempted to eliminate thixotropic materials from the tube, but the designs are generally inadequate because they do not meet all of the requirements and/or are expensive to manufacture. One example that eliminates the thixotropic material from the tube is U.S. Pat. No. 4,909,592, which discloses a tube having conventional water-swellaable tapes and/or yarns disposed therein. For instance, conventional water-swellaable tapes are typically formed from two thin non-woven layers that sandwich a water-swellaable powder therebetween, thereby forming a relatively thin tape that does not fill the space inside a buffer tube. Consequently, conventional water-swellaable tapes do not provide adequate coupling for the optical waveguides because of the unfilled space. Additionally, the space allows water within the tube to migrate along the tube, rather than be contained by the conventional water-swellaable tape. Thus, this design requires a large number of water-swellaable components within the tube for adequately coupling the optical fibers with the tube. Moreover, the use of large numbers of water-swellaable components inside a buffer tube is not economical because it increases the manufacturing complexity along with the cost of the cable.

Another example that eliminates the thixotropic material from a fiber optic cable is U.S. Pat. No. 6,278,826, which discloses a foam having a moisture content greater than zero

that is loaded with super-absorbent polymers. The moisture content of the foam is described as improving the flame-retardant characteristics of the foam. Likewise, the foam of this design is relatively expensive and increases the cost of
5 the cable.

BRIEF DESCRIPTION OF THE FIGS.

Fig. 1 is a cross-sectional view of a tube assembly according to the present invention.

Fig. 1a is a cross-sectional view of another tube
10 assembly according to the present invention.

Fig. 2 is a cross-sectional view of the dry insert of the tube assembly of Fig. 1.

Fig. 2a is a cross-sectional view of another dry insert according to the present invention.

15 Figs. 2b-2d depict various configurations of an adhesive/glue applied to the dry insert of Fig. 2.

Figs. 3 and 3a are cross-sectional views of tube assemblies according to the present invention having the dry insert of Fig. 2a.

20 Fig. 4 is a schematic representation of a manufacturing line according to the present invention.

Fig. 5 is a cross-sectional view of a fiber optic cable according to the present invention using the tube assembly of Fig. 1.

25 Fig. 6 is a cross-sectional view of a fiber optic cable according to the present invention using the tube assembly of Fig. 3.

Fig. 7 is a perspective view of another dry insert according to the concepts of the present invention.

30 Fig. 8 is a cross-sectional view of another dry insert according to the concepts of the present invention.

Fig. 9 is a perspective view of another dry insert according to the concepts of the present invention.

35 Fig. 10 is a perspective view of another dry insert according to the concepts of the present invention.

Fig. 11 is a cross-sectional view of a fiber optic cable having a conventional grease filled tube assembly.

Fig. 12 is a cross-sectional view of a fiber optic cable having a conventional dry tube assembly.

5 Fig. 13 is a cross-sectional view of a fiber optic cable with an armor layer according to the present invention.

Fig. 14 is a cross-sectional view of a tubeless fiber optic cable according to the present invention.

10 Fig. 15 is a cross-sectional view of a fiber optic cable having stranded tubes according to the present invention.

Fig. 16 is a cross-sectional view of the dry insert of Fig. 2a having an additional layer.

15 Fig. 17 is a cross-sectional view of still another embodiment of the dry insert according to the present invention.

Fig. 18 is a plan view of the dry insert of Fig. 17.

Figs. 19 and 20 are cross-sectional views of tubeless fiber optic cables according to the present invention.

DETAILED DESCRIPTION OF THE INVENTION

20 The present invention will now be described more fully hereinafter with reference to the accompanying drawings showing preferred embodiments of the invention. The invention may, however, be embodied in many different forms and should not be construed as limited to the embodiments set forth
25 herein; rather, these embodiments are provided so that the disclosure will fully convey the scope of the invention to those skilled in the art. The drawings are not necessarily drawn to scale but are configured to clearly illustrate the invention.

30 Illustrated in Fig. 1 is an exemplary tube assembly 10 according to one aspect of the present invention. Tube assembly 10 includes at least one optical waveguide 12, at least one dry insert 14, and a tube 18. In this case, the at least one optical waveguide 12 is in the form of a stack of
35 ribbons 13 having a diagonal D dimension across the corners of

the stack. Dry insert 14 generally surrounds the at least one optical waveguide 12 and forms core 15, which is disposed within tube 18. Dry insert 14 performs functions such as cushioning, coupling, inhibiting the migration of water, and accommodates bending. Dry insert 14 is advantageous because the optical waveguides are easily removed therefrom without leaving a residue or film that requires cleaning before connectorization. Moreover, unlike conventional thixotropic materials, dry insert 14 does not change viscosity with temperature variations or have a propensity to drip from an end of the tube at high temperatures. Furthermore, tube assembly 10 can include other suitable components such as a polyester binder thread 17 to hold dry insert 14 about optical waveguide 12. Likewise, two or more threads may be stitched together for holding dry insert 14 together before extruding tube 18 therearound. Fig. 1a shows tube assembly 10', which is a variation of tube assembly 10. Specifically, tube assembly 10' includes a plurality of loose optical waveguides 12, instead of the stack of ribbons 13. In this case, tube assembly 10' includes twenty-four loose optical waveguides 12 having diagonal dimension D, but any suitable number of optical waveguides may be used. Moreover, optical waveguides 12 may be bundled into one or more groups using binders, water-swallowable threads, tapes, wraps, or other suitable materials. Additionally, tube assemblies 10 or 10' can be a portion of cable as shown in Fig. 5. Furthermore, dry inserts 14 according to the present invention may be used with tubeless cable designs.

As depicted, optical waveguide 12 is an optical fiber that forms a portion of an optical fiber ribbon. In this case, the optical waveguides are a plurality of single-mode optical fibers in a ribbon format that form ribbon stack 13. Ribbon stack 13 can include helical or S-Z stranding. Additionally, other types or configurations of optical waveguides can be used. For example, optical waveguide 12 can be multi-mode, pure-mode, erbium doped, polarization-maintaining fiber, other suitable types of light waveguides, and/or combinations

thereof. Moreover, optical waveguide 12 can be loose or in bundles. Each optical waveguide 12 may include a silica-based core that is operative to transmit light and is surrounded by a silica-based cladding having a lower index of refraction than the core. Additionally, one or more coatings can be applied to optical waveguide 12. For example, a soft primary coating surrounds the cladding, and a relatively rigid secondary coating surrounds the primary coating. In one embodiment, one or more optical waveguides 12 include a coating system as disclosed in U.S. Pat. App. Ser. No. 10/632,219 filed on July 18, 2003, the disclosure of which is incorporated herein by reference. Optical waveguide 12 can also include an identifying means such as ink or other suitable indicia for identification. Suitable optical fibers are commercially available from Corning Incorporated of Corning, New York.

In other embodiments, ribbon stack 13 can have a corner optical waveguide(s) 12a with a predetermined MAC number, thereby inhibiting optical attenuation of the corner optical waveguide when subjected to compressive forces. Stated another way, selecting corner optical waveguides with a predetermined MAC number places optical waveguides that are less sensitive to optical attenuation from compressive forces in ribbon stack locations that experience relatively high levels of compression. As used herein, MAC number is calculated as a mode field diameter (MFD) divided by a cutoff wavelength for the given optical waveguide 12a where both quantities are expressed in micrometers so that the MAC number is dimensionless. In other words, MFD is typically expressed in micrometers and cutoff wavelength is typically expressed in nanometers, so the cutoff wavelength must be divided by 1000 to convert it to micrometers, thereby yielding a dimensionless MAC number.

In one embodiment, one or more of the corner optical waveguides 12a have a predetermined MAC number. Specifically, the MAC number is about 7.35 or less, more preferably about 7.00 or less, and most preferably about 6.85 or less. By way

of example, corner optical waveguide(s) 12a is selected with a MFD of 9.11 μm or less and a cutoff wavelength of 1240 nm or more, thereby yielding 7.35 or less for the MAC number. Generally speaking, the MAC number is directly proportional to
5 MFD and inversely proportional to the cutoff wavelength. Ribbon stack 13 has four corner optical waveguides 12a; however, other ribbon stack configurations can include more corner positions. For instance, a ribbon stack having a generally plus sign shape includes eight outer corners.
10 Likewise, other ribbon stack configurations may have other numbers of corner positions.

Additionally, ribbon embodiments of the present invention may have a positive excess ribbon length (ERL), although a negative ERL is possible. As used herein, ERL is defined as
15 the length of the particular ribbon minus the length of the tube or cable containing the ribbon divided by the length of the tube or cable containing the ribbon, which can be expressed as a percentage by multiplying by 100. Whether the ERL is calculated using the tube length or the cable length
20 depends on the particular configuration. Moreover, individual ribbons of a cable can have different values of ERL. By way of example, ribbons of the cable have a positive ERL, preferably a positive ERL in the range of about 0.0% to about 0.2% or greater. Likewise, embodiments having loose or bundled
25 optical fibers may include a positive excess fiber length (EFL).

Figs. 2 and 2a illustrate cross-sectional views of explanatory dry inserts 14 according to the present invention. Dry inserts 14 are formed from an elongate material or
30 materials that are capable of being paid off from a reel for a continuous application during manufacture. Dry inserts 14 may be formed from a plurality of layers (Fig. 2) that can perform different functions; however, dry insert 14 (Fig. 2a) can also be a single layer such as a felt material that is
35 compressible. Dry insert 14 cushions optical waveguide 12 from tube 18, thereby maintaining optical attenuation of optical waveguide 12 below about 0.4 dB/km at a reference wavelength

of 1310 nm and 0.3 dB/km at a reference wavelengths of 1550 nm and 1625 nm. In one embodiment, dry insert 14 is formed from two distinct layers and/or materials. For instance, Fig. 2 depicts a first layer 14a of dry insert 14 that is a compressible layer and second layer 14b that is a water-swallowable layer. In this case, first layer 14a is formed from a compressible material having a predetermined spring constant for providing adequate coupling characteristics. By way of example, the first layer is a foam tape, preferably, an open cell foam tape; however, any suitable compressible material can be used such as a closed cell foam tape. Second layer 14b is a water-swallowable layer such as a tape having a water-swallowable powder that inhibits the migration of water within tube 18. Additionally, single layer dry inserts according to the present invention can have similar characteristics.

Fig. 2a depicts another dry insert 14 having a single, non-woven layer of felt made of one or more materials. In this case, dry insert 14 comprises a plurality of water-swallowable filaments 24a along with other filaments 24b that are non-swallowable in water, thereby forming a layer of felt having multiple materials. As used herein, felt means a material comprising one or more types of non-continuous filaments and/or fibers which have been caused to adhere and mat together through the action of heat, moisture, chemicals, pressure, or a combination of the foregoing actions, thereby forming a relatively thick and compressible layer. Water-swallowable filaments 24a may comprise any suitable water-swallowable material, but preferably include at least one superabsorbant polymer. Preferred superabsorbent polymers are partially cross-linked polymers that absorb many times their own weight in water and swell considerably without dissolving, for example, acrylate, urethane or cellulosic-based materials. By way of example, the single layer dry insert 14 of Fig. 2a may include about 25% or less by weight of water-swallowable filaments 24a and about 75% or more by weight of other filaments 24b; however, other suitable ratios are possible. Likewise, in this configuration the density of the dry insert

can be influenced to meet the needs of the tube assembly. Generally speaking, the single layer felt dry insert is a compressible layer for cushioning and coupling of the optical fibers and may include water-swella-
5 ble materials for inhibiting the migration of water. Unlike conventional water-swella-
ble tapes the single layer felt has a relatively large thickness that generally speaking fills spaces within the tube or cavity. Moreover, the felt dry insert may use water-swella-
10 ble filaments that aid in providing compressibility or fluffiness of the dry insert, rather than water-swella-
ble powders that are used in conventional water-swella-
ble tapes.

Other filaments 24b may include any suitable filament and/or fiber material such as polymer filaments like polypropylene, polyethylene, and polyesters, likewise, other
15 suitable materials such as cottons, nylon, rayons, elastomers, fiberglass, aramids, polymers, rubber-based urethanes, composite materials and/or blends thereof may be included as a
portion of other filaments 24b and may be tailored for providing specific characteristics. For instance, polymer
20 filaments can be used for coupling the dry insert with the tube when the same is extruded thereover. In other words, the hot tube extrudate at least partially melts the polymer
filaments, thereby causing adhesion between the two. Another example is that elastomeric fibers can be included in the dry
25 insert for providing improved coupling of optical waveguide 12 with tube 18. The use of elastomeric fibers, or other suitable material, may allow for the coupling of dry insert 14
to tube 18, and/or optical waveguide 12 to dry insert 14 by increasing a coefficient of friction. Of course, as depicted
30 in Figs. 2b-2d adhesives, glues, (Figs. 2b-2d) or other methods may be used for attaching the dry insert to the tube. Furthermore, the dry insert may include other chemicals or
additives to influence properties such as flame-retardance.

Figs. 3 and 3a depict tube assemblies 30 and 30' that are
35 similar to tube assemblies 10 and 10' depicted in Figs. 1 and 1a, except they employ the dry insert of Fig. 2a. Furthermore, tube assemblies 30 and 30' can be included as a

portion of a fiber optic cable 60 as depicted in Fig. 6. Dry insert 14 of Fig. 2a advantageously performs the functions of cushioning, coupling, inhibiting the migration of water, and accommodates bending like the multi-layer dry insert. Additionally, the single layer construction may reduce costs and improve cable manufacturability.

Additionally, the dry insert of Fig. 2a can include one or more other layers in addition to the felt for tailoring performance characteristics. Illustratively, Fig. 16 depicts another dry insert 14 having a second layer 162 attached to one side of the felt dry insert of Fig. 2a. Using a second layer attached to the felt dry insert allows for several different dry insert configurations. For instance, the felt dry insert may exclude water-swellaable filaments, and instead second layer 162 is a water-swellaable tape that inhibits the migration of water. In another embodiment, the felt includes water-swellaable filaments and a water-swellaable tape attached thereto. In a further embodiment, second layer 162 is a meltable layer having a polymer that at least partially melts during extrusion of the tube thereover. Likewise, other dry insert embodiments are possible.

Illustratively, Figs. 17 and 18 depict dry insert 14 having a first and a second layer 172,176 with at least one water-swellaable layer 174 disposed in a compartment 174a therebetween. In other words, water-swellaable layer 174 is generally contained in one or more compartments 174a between first and second layers 172,176 that act as backing layers. By way of example, first and second layers may be formed of nylon, polymers, fiberglass, aramid, w-s tape, composite materials, or any other suitable materials in a tape-like configuration. Materials for this configuration should provide the necessary strength to endure the cabling process and intended use. Additionally, at least one of the first and/or second layers should be porous for water penetration. Preferably, water-swellaable layer 174 includes non-continuous water-swellaable filaments loosely disposed between first and second layers 172,174, thereby forming a compressible dry

insert. Suitable water-swellaible filaments are, for example, LANSEAL materials available from Toyobo of Osaka, Japan or OASIS materials available from Technical Absorbents Ltd. of South Humberside, United Kingdom. Additionally, water-swellaible layer 174 may comprise a water swellaible powder along with the water swellaible filaments. Moreover, water-swellaible layer 174 may include other filaments as a filler to increase the thickness of the water swellaible layer and thus of the dry insert, while reducing the cost of the dry insert. The other filaments may comprise any suitable non-swellaible as discussed herein.

Furthermore, first and second layers 172,176 are attached together so that water-swellaible layer 174 is generally sandwiched therebetween, thereby creating one or more compartments 174a, which generally speaking traps water-swellaible layer 174 therein. At a minimum, layers 172,176 are attached together at a plurality of seams 178 along the longitudinal edges, but are attachable in other ways. Layers 172,176 are attachable using adhesives, heat where appropriate, stitching, or other suitable methods. In preferred embodiments, layers 172,176 are attached at intermediate positions along the length of the dry insert. As shown in Fig. 18, layers 172,176 are attached together using a diamond pattern of seams 178; however, other suitable patterns such as triangular, semi-circular, or curvilinear patterns are possible, thereby creating the plurality of compartments 174a. Additionally, the seams between compartments can be arranged for aiding in forming the dry insert about the optical waveguides. Compartmentalization of water-swellaible layer 174 advantageously inhibits moving or shifting of the material beyond the individual compartment. Moreover, the compartments add a pillowly texture to the dry insert.

In further embodiments, first and second layers 172,176 need not comprise the same material. In other words, the materials of the first and second layers may be selected to tailor the dry insert behavior according to the needs of each side of the dry insert. For instance, the first layer is

tailored to adhere with the extruded tube and the second layer is tailored to have a smooth finish for contact with the optical waveguides. Additionally, in other embodiments the dry insert can have more than a first and second layers to, 5 for instance, optimize the attachment of the layers, coupling, and/or inhibit water migration. However, the dry insert should not be so stiff that it is too difficult to manufacture into a cable assembly. Additionally, as shown in Fig. 2a it may be advantageous for one of the longitudinal edges of any 10 of the dry inserts to have a tapered edges 24c so that the longitudinal edges may overlap without a large bulge when the dry insert is formed about the at least on optical fiber 12.

Dry inserts 14 of the present invention preferably have a water-swell speed so that the majority of swell height of the 15 water-swellable substance occurs within about 120 seconds or less of being exposed to water, more preferably about 90 seconds or less. Additionally, dry inserts 14 preferably has a maximum swell height of about 18 mm for distilled water and about 8 mm for a 5% ionic water solution, i.e., salt water; 20 however, dry inserts with other suitable maximum swell heights may be used.

Dry inserts 14 may be compressed during assembly so that it provides a predetermined normal force that inhibits optical waveguide 12 from being easily displaced longitudinally along 25 tube 18. Dry inserts 14 preferably have an uncompressed height h of about 5 mm or less for minimizing the tube diameter and/or cable diameter; however, any suitable height h can be used for dry inserts 14. By way of example, a single layer dry insert 14 can have an uncompressed height in the range of 30 about 0.5 mm to about 2 mm, thereby resulting in a tube assembly having a relatively small diameter. Moreover, height h of dry insert 14 need not be constant across the width, but can vary, thereby conforming to the cross-sectional shape of the optical waveguides and providing improved cushioning to 35 improve optical performance (Fig. 10). Compression of dry insert 14 is actually a localized maximum compression of dry insert 14. In the case of Fig. 1, the localized maximum

compression of dry insert 14 occurs at the corners of the ribbon stack across the diameter. Calculating the percentage of compression of dry insert 14 in Fig. 1 requires knowing an inner diameter of tube 18, a diagonal D dimension of the ribbon stack, and an uncompressed height h of dry insert 14. By way of example, inner diameter of tube 18 is 7.1 mm, diagonal D of the ribbon stack is 5.1 mm, and the uncompressed height h of dry insert 14 across a diameter is 3.0 mm (2 times 1.5 mm). Adding diagonal D (5.1 mm) and the uncompressed height h of dry insert 14 across the diameter (3.0 mm) yields an uncompressed dimension of 8.1 mm. When placing the ribbon stack and dry insert 14 and into tube 18 with an inner diameter of 7.1 mm, dry insert is compressed a total of 1 mm (8.1 mm - 7.1 mm). Thus, dry insert 14 is compressed by about thirty percent across the diameter of tube 18. According to the concepts of the present invention the compression of dry insert 14 is preferably in the range of about 10% to about 90%; however, other suitable ranges of compression may provide the desired performance. Nonetheless, the compression of dry insert 14 should not be so great as to cause undue optical attenuation in any of the optical waveguides.

In other embodiments, first layer 14a of dry insert 14 is uncompressed in tube assembly 10, but begins to compress if optical waveguide movement is initiated. Other variations include attaching, bonding, or otherwise coupling a portion of dry insert 14 to tube 18. For example, adhesives, glues, elastomers, and/or polymers 14c are disposed on a portion of the surface of dry insert 14 that contacts tube 18 for attaching dry insert 14 to tube 18. Additionally, it is possible to helically wrap dry insert 14 about optical waveguide 12, instead of being longitudinally disposed. In still further embodiments, two or more dry inserts can be formed about one or more optical waveguides 12 such as two halves placed within tube 18.

Other embodiments may include a fugitive glue/adhesive for coupling cable core 15 and/or dry insert 14 with tube 18. The glue/adhesive or the like is applied to the radially

outward surface of dry insert 14, for instance, during the manufacturing process. The fugitive glue/adhesive is applied while hot or melted to the outer surface of dry insert 14 and then is cooled or frozen when the cable is quenched or cools
5 off. By way of example, a suitable fugitive glue is available from National Starch and Chemical Company of Bridgewater, NJ under the tradename LITE-LOK® 70-003A. The fugitive glue or other suitable adhesive/material may be applied in beads having a continuous or an intermittent configuration as shown
10 in Figs. 2b-2d. For instance, one or more adhesive/glue beads may be longitudinally applied along the dry insert, longitudinally spaced apart beads, in a zig-zag bead along the longitudinal axis of the dry insert, or in any other suitable configuration.

15 In one application, a plurality of beads of fugitive glue/ adhesive or the like is applied to dry insert 14. For instance, three continuous, or non-continuous, beads can be disposed at locations so that when the dry insert is formed about the ribbon stack the beads are about 120 degrees apart.
20 Likewise, four beads can be disposed at locations so they are about 90 degrees apart when the dry insert is formed about the optical waveguides. In embodiments having the beads spaced apart along the longitudinal axis, the beads may have a longitudinal spacing S of about 20 mm and about 800 mm or
25 more; however, other suitable spacing may be used. Additionally, beads may be intermittently applied for minimizing the amount of material required, thereby reducing manufacturing expense while still providing sufficient coupling/adhesion.

30 Since tube assemblies 10 are not filled with a thixotropic material the tube may deform or collapse, thereby forming an oval shaped tube instead of a round tube. U.S. Pat. App. No. 10/448,509 filed on May 30, 2003, the disclosure of which is incorporated herein by reference, discusses dry
35 tube assemblies where the tube is formed from a bimodal polymeric material having a predetermined average ovality. As used herein, ovality is the difference between a major

diameter D1 and a minor diameter D2 of tube 18 divided by major diameter D1 and multiplied by a factor of one-hundred, thereby expressing ovality as a percentage. Bimodal polymeric materials include materials having at least a first polymer material having a relatively high molecular weight and a second polymer material having a relatively low molecular weight that are manufactured in a dual reactor process. This dual reactor process provides the desired material properties and should not be confused with simple post reactor polymer blends that compromise the properties of both resins in the blend. In one embodiment, the tube has an average ovality of about 10 percent or less. By way of example, tube 18 is formed from a HDPE available from the Dow Chemical Company of Midland, Michigan, under the tradename DGDA-2490 NT.

Coupling of the optical waveguide in the tube assembly may be measured using a normalized optical ribbon pullout force test. The ribbon pullout force test measures the force (N/m) required to initiate movement of a ribbon stack from a 10-meter length of cable. Of course, this test is equally applicable to loose or bundled optical waveguides. Specifically, the test measures the force required to initiate movement of a stack of ribbons, or other configurations of optical waveguides, relative to the tube and the force is divided by the length of the cable, thereby normalizing the optical ribbon pullout force. Preferably, the ribbon pullout force is in the range of about 0.5 N/m and about 5.0 N/m, more preferably, in the range of about 1 N/m to about 4 N/m.

Fig. 4 schematically illustrates an exemplary manufacturing line 40 for tube assembly 10 according to the present invention. Manufacturing line 40 includes at least one optical waveguide payoff reel 41, a dry insert payoff reel 42, an optional compression station 43, an glue/adhesive station 43a, a binding station 44, a cross-head extruder 45, a water trough 46, and a take-up reel 49. Additionally, tube assembly 10 may have a sheath 20 therearound, thereby forming a cable 50 as illustrated in Fig. 5. Sheath 20 can include strength members 19a and a jacket 19b, which can be

manufactured on the same line as tube assembly 10 or on a second manufacturing line. The exemplary manufacturing process includes paying-off at least one optical waveguide 12 and dry insert 14 from respective reels 41 and 42. Only one payoff reel for optical waveguide 12 and dry insert 14 are shown for clarity; however, the manufacturing line can include any suitable number of payoff reels to manufacture tube assemblies and cables according to the present invention. Next, dry insert 14 is compressed to a predetermined height h at compression station 43 and optionally an adhesive/glue is applied to the outer surface of dry insert 14 at station 43a. Then dry insert 14 is generally positioned around optical waveguide 12 and if desired a binding station wraps or sews one or more binding threads around dry insert 14, thereby forming core 15. Thereafter, core 15 is feed into cross-head extruder 45 where tube 18 is extruded about core 15, thereby forming tube assembly 10. Tube 18 is then quenched in water trough 46 and then tube assembly 10 is wound onto take-up reel 49. As depicted in the dashed box, if one manufacturing line is set-up to make cable 50, then strength members 19a are paid-off reel 47 and positioned adjacent to tube 18, and jacket 19b is extruded about strength members 19a and tube 18 using cross-head extruder 48. Thereafter, cable 50 passes into a second water trough 46 before being wound-up on take-up reel 49. Additionally, other cables and/or manufacturing lines according to the concepts of the present invention are possible. For instance, cables and/or manufacturing lines may include a water-swellaable tape 19c and/or an armor between tube 18 and strength members 19a; however, the use of other suitable cable components are possible.

Additionally, a ribbon coupling force test may be used for modeling the forces applied to the optical waveguide(s) when subjecting a cable to, for example, pulling during installation of the cable. Although the results between the ribbon pullout force and the ribbon coupling force may have forces in the same general range, the ribbon coupling force is generally a better indicator of actual cable performance.

Specifically, the ribbon coupling test simulates an underground cable installation in a duct by applying 600 pounds of tension on a 250 m length of cable by placing pulling sheaves on the respective sheathes of the cable ends.

5 Like the ribbon pullout test, this test is equally applicable to loose or bundled optical waveguides. However, other suitable loads, lengths, and/or installation configurations can be used for characterizing waveguide coupling in other simulations. Then, the force on the optical waveguide(s)

10 along its length is measured from the end of cable. The force on the optical waveguide(s) is measured using a Brillouin Optical Time-Domain Reflectometer (BOTDR). Determining a best-fit slope of the curve normalizes the ribbon coupling force. Thus, according to the concepts of the present

15 invention the coupling force is preferably in the range of about 0.5 N/m to about 5.0 N/m, more preferably, in the range of about 1 N/m to about 4 N/m. However, other suitable ranges of coupling force may provide the desired performance.

Additionally, the concepts of the present invention can

20 be employed with other configurations of the dry insert. As depicted in Fig. 7, dry insert 74 has a first layer 74a and a second layer 74b that includes different suitable types of water-swella-ble substances. In one embodiment, two different water-swella-ble substances are disposed in, or on, second

25 layer 14b so that tube assembly 10 is useful for multiple environments and/or has improved water-blocking performance. For instance, second layer 14b can include a first water-swella-ble component 76 effective for ionized liquids such as saltwater and a second water-swella-ble component 78 effective

30 for non-ionized liquids. By way of example, first water-swella-ble material is a polyacrylamide and second water-swella-ble material is a polyacrylate superabsorbent. Moreover, first and second water-swella-ble components 76,78 can occupy predetermined sections of the water-swella-ble tape.

35 By alternating the water-swella-ble materials, the tape is useful for standard applications, salt-water applications, or both. Other variations of different water-swella-ble

substances include having a water-swellaable substance with different swell speeds, gel strengths and/or adhesion with the tape.

Fig. 8 depicts another embodiment of the dry insert. Dry insert 84 is formed from three layers. Layers 84a and 84c are water-swellaable layers that sandwich a layer 84b that is compressible for providing a coupling force to the at least one optical waveguide. Likewise, other embodiments of the dry insert can include other variations such at least two compressible layers sandwiching a water-swellaable layer. The two compressible layers can have different spring constants for tailoring the normal force applied to the at least optical waveguide.

Fig. 9 illustrates a dry insert 94 having layers 94a and 94b according to another embodiment of the present invention. Layer 94a is formed from a closed-cell foam having at least one perforation 95 therethrough and layer 94b includes at least one water-swellaable substance; however, other suitable materials can be used for the compressible layer. The closed-cell foam acts as a passive water-blocking material that inhibits water from migrating therealong and perforation 95 allows an activated water-swellaable substance of layer 94b to migrate radially inward towards the optical waveguide. Any suitable size, shape, and/or pattern of perforation 95 that allows the activated water-swellaable substance to migrate radially inward to effectively block water is permissible. The size, shape, and/or pattern of perforations can be selected and arranged about the corner optical waveguides of the stack, thereby improving corner optical waveguide performance. For example, perforations 95 can provide variation in dry insert compressibility, thereby tailoring the normal force on the optical waveguides for maintaining optical performance.

Fig. 10 depicts dry insert 104, which illustrates other concepts of the present invention. Dry insert 104 includes layers 104a and 104b. Layer 104a is formed of a plurality of non-continuous compressible elements that are disposed on

layer 104b, which is a continuous water-swellable layer. In one embodiment, the elements of layer 104a are disposed at regular intervals that generally correlate with the lay length of a ribbon stack. Additionally, the elements have a height h that varies across their width w. Stated another way, the elements are shaped to conform to the shape of the optical waveguides they are intended to generally surround.

Fig. 13 depicts cable 130, which is another embodiment of the present invention that employs tube assembly 10. Cable 130 includes a sheath system 137 about tube assembly 10 for protecting tube assembly 10 from, for instance, crushing forces and environmental effects. In this case, sheath system 137 includes a water-swellable tape 132 that is secured by a binder thread (not visible), a pair of ripcords 135, an armor tape 136, and a jacket 138. Armor tape 136 is preferably rolled formed; however, other suitable manufacturing methods may be used. The pair of ripcords 135 are generally disposed about one-hundred and eighty degrees apart with about ninety degree intervals from the armor overlap, thereby inhibiting the shearing of ripcord on an edge of the armor tape during use. In preferred embodiments, ripcords suitable for ripping through an armor tape have a construction as disclosed in U.S. Pat. App. No. 10/652,046 filed on August 29, 2003, the disclosure of which is incorporated herein by reference. Armor tape 136 can be either a dielectric or a metallic material. If a dielectric armor tape is used the cable may also include a metallic wire for locating the cable in buried applications. In other words, the metallic wire makes the cable tonable. Jacket 138 generally surrounds armor tape 136 and provides environmental protection to cable 130. Of course, other suitable sheath systems may be used about the tube assembly.

Fig. 14 depicts fiber optic cable 140. Cable 140 includes at least one optical waveguide 12 and a dry insert 14 forming a cable core 141 within a sheath system 142. In other words, cable 140 is a tubeless design since access to the cable core 141 is accomplished by solely cutting open sheath

system 142. Sheath system 142 also includes strength members 142a embedded therein and disposed at about 180 degrees apart, thereby imparting a preferential bend to the cable. Of course, other sheath systems configurations such as different types, quantities, and/or placement of strength members 142a are possible. Cable 140 may also include one or more ripcords 145 disposed between cable core 141 and sheath 142 for ripping sheath 142, thereby allowing the craftsman easy access to cable core 141.

10 Fig. 15 depicts a fiber optic cable 150 having a plurality of tube assemblies 10 stranded about a central member 151. Specifically, tube assemblies 10 along with a plurality of filler rods 153 are S-Z stranded about central member 151 and are secured with one or more binder threads 15 (not visible), thereby forming a stranded cable core. The stranded cable core has a water-swellable tape 156 thereabout, which is secured with a binder thread (not visible) before jacket 158 is extruded thereover. Optionally, aramid fibers, other suitable strength members and/or water blocking components such as water-swellable yarns may be stranded about 20 central member 151, thereby forming a portion of the stranded cable core. Likewise, water-swellable components such as a yarn or tape may be placed around central member 151 for inhibiting water migration along the middle of cable 150. 25 Other variations of cable 150 can include an armor tape, an inner jacket, and/or different numbers of tube assemblies.

Figs. 19 and 20 depict explanatory tubeless cable designs according to the present invention. Specifically, cable 190 is a drop cable having at least one optical waveguide 12 generally surrounded by dry insert 14 within a cavity of jacket 198. Cable 190 also includes at least one strength member 194. Other tubeless drop cable configurations are also possible such as round or oval configurations. Fig. 20 depicts a tubeless figure-eight drop cable 200 having a messenger section 202 and a carrier section 204 connected by a common jacket 208. Messenger section 202 includes a strength member 203 and carrier section 204 includes a cavity having at 35

least one optical waveguide 12 that is generally surrounded by dry insert 14. Carrier section 204 can also include at least one anti-buckling member 205 therein for inhibiting shrinkage when carrier section 204 is separated from messenger section 5 202. Although, Figs. 19 and 20 depict the dry insert of Fig. 2a any suitable dry insert may be used.

Many modifications and other embodiments of the present invention, within the scope of the appended claims, will become apparent to a skilled artisan. For example, optical 10 waveguides can be formed in a variety of ribbon stacks or configurations such as a stepped profile of the ribbon stack. Cables according to the present invention can also include more than one optical tube assembly stranded helically, rather than S-Z stranded configurations. Additionally, dry inserts 15 of the present invention can be laminated together as shown or applied as individual components. Therefore, it is to be understood that the invention is not limited to the specific embodiments disclosed herein and that modifications and other embodiments may be made within the scope of the appended 20 claims. Although specific terms are employed herein, they are used in a generic and descriptive sense only and not for purposes of limitation. The invention has been described with reference to silica-based optical waveguides, but the inventive concepts of the present invention are applicable to 25 other suitable optical waveguides and/or cable configurations.

THAT WHICH IS CLAIMED:

1. An optical tube assembly comprising:

a tube;

at least one optical waveguide, the optical waveguide
5 being disposed in the tube; and

at least one dry insert, the dry insert having a first
layer comprising a felt having at least one type of non-
continuous filament, wherein the dry insert is disposed within
the tube and generally surrounds the at least one optical
10 waveguide.

2. The optical tube assembly of claim 1, the at least one
dry insert includes at least two different types of non-
continuous filaments.

15

3. The optical tube assembly of claim 1, the dry insert
further including a plurality of water-swellaable filaments.

4. The optical tube assembly of claim 3, the plurality of
20 water-swellaable filament comprising about 25% or less, by
weight, of the dry insert.

5. The optical tube assembly of claim 1, the dry insert
further comprising a second layer.

25

6. The optical tube assembly of claim 5, the second layer
being a water-swellaable tape.

7. The optical tube assembly of claim 1, wherein the at
30 least one optical waveguide comprises a portion of a fiber
optic ribbon.

8. The optical tube assembly of claim 1, wherein the at
least one optical waveguide has a normalized pull-out force
35 between about 0.5 N/m and about 5.0 N/m.

9. The optical tube assembly of claim 1, wherein the at least one optical waveguide has a normalized pull-out force between about 1 N/m and about 4 N/m.

5 10. The optical tube assembly of claim 1, wherein the at least one optical waveguide comprises a portion of a ribbon, the ribbon having a normalized ribbon pull-out force between about 0.5 N/m and about 5.0 N/m.

10 11. The optical tube assembly of claim 1, wherein the at least one dry insert has an uncompressed height h of about 5 mm or less.

12. The optical tube assembly of claim 1, wherein the at
15 least one dry insert has an uncompressed height h of about 0.5 mm or more.

13. The optical tube assembly of claim 1, wherein the optical tube assembly comprises a portion of a fiber optic cable.

20

14. The optical tube assembly of claim 1, wherein the optical tube assembly comprises a portion of a fiber optic cable, the fiber optic cable including an armor tape.

25 15. The optical tube assembly of claim 1, wherein the at least one optical waveguide comprises a portion of a ribbon stack having at least one corner optical waveguide, the at least corner optical waveguide having a MAC number of about 7.35 or less.

30

16. The optical tube assembly of claim 1, the dry insert having two longitudinal edges and at least one of the two longitudinal edges being tapered for overlapping the two longitudinal edges.

35

17. An optical tube assembly comprising:
a tube;

at least one optical waveguide, the at least one optical waveguide being disposed within the tube and having a positive excess length relative to a tube length; and

at least one dry insert, the at least one dry insert
5 having a first layer comprising a felt having at least one type of non-continuous filament, wherein the at least one dry insert generally surrounds the at least one optical waveguide, the at least one optical waveguide having an optical attenuation of about 0.4 dB/km or less.

10

18. The optical tube assembly of claim 17, the at least one dry insert including at least two different types of non-continuous filaments.

15

19. The optical tube assembly of claim 17, the dry insert further including a plurality of water-swellaable filaments.

20

20. The optical tube assembly of claim 19, the plurality of water-swellaable filament comprising about 25% or less, by weight, of the dry insert.

21. The optical tube assembly of claim 17, the dry insert further comprising a second layer.

25

22. The optical tube assembly of claim 21, the second layer being a water-swellaable tape.

30

23. The optical tube assembly of claim 17, wherein the at least one optical waveguide comprises a portion of a fiber optic ribbon.

24. The optical tube assembly of claim 17, wherein the at least one optical waveguide has a normalized pull-out force between about 0.5 N/m and about 5.0 N/m.

35

25. The optical tube assembly of claim 17, wherein the at least one optical waveguide comprises a portion of a ribbon,

the ribbon having a normalized ribbon pull-out force between about 0.5 N/m and about 5.0 N/m.

26. The optical tube assembly of claim 17, wherein the at
5 least one dry insert has an uncompressed height h of about 5 mm or less.

27. The optical tube assembly of claim 17, wherein the at
10 least one dry insert has an uncompressed height h of about 0.5 mm or more.

28. The optical tube assembly of claim 17, wherein the optical tube assembly comprises a portion of a fiber optic cable.

15

29. The optical tube assembly of claim 17, wherein the optical tube assembly comprises a portion of a fiber optic cable, the fiber optic cable including an armor tape.

20 30. The optical tube assembly of claim 17, wherein the at least one optical waveguide comprises a portion of a ribbon stack having at least one corner optical waveguide, the at least corner optical waveguide having a MAC number of about 7.35 or less.

25

31. The optical tube assembly of claim 17, the dry insert having two longitudinal edges and at least one of the two longitudinal edges being tapered for overlapping the two longitudinal edges.

30

32. An optical tube assembly comprising:
a tube;
at least one optical waveguide; and
at least one dry insert, the at least one dry insert
35 having a first layer comprising a felt having at least one type of non-continuous water-swellable filament, wherein the

at least one optical waveguide has a normalized pull-out force between about 0.5 N/m and about 5.0 N/m.

33. The optical tube assembly of claim 32, the at least one
5 dry insert including at least two different types of non-continuous filaments.

34. The optical tube assembly of claim 32, the dry insert
further including a plurality of water-swellaable filaments.

10

35. The optical tube assembly of claim 34, the plurality of
water-swellaable filament comprising about 25% or less, by
weight, of the dry insert.

15 36. The optical tube assembly of claim 32, the dry insert
further comprising a second layer.

37. The optical tube assembly of claim 36, the second layer
being a water-swellaable tape.

20

38. The optical tube assembly of claim 32, the normalized
pull-out force being between about 1 N/m and about 4 N/m.

39. The optical tube assembly of claim 32, the at least one
25 optical waveguide being a portion of a ribbon.

40. The optical tube assembly of claim 39, wherein the ribbon
has a normalized pull-out force between about 1 N/m and about
4 N/m.

30

41. The optical tube assembly of claim 32, wherein the at
least one dry insert has an uncompressed height h of about 5
mm or less.

35 42. The optical tube assembly of claim 32, wherein the at
least one dry insert has an uncompressed height h of about 0.5

mm or more.

43. The optical tube assembly of claim 32, wherein the optical tube assembly comprises a portion of a fiber optic
5 cable.

44. The optical tube assembly of claim 32, wherein the optical tube assembly comprises a portion of a fiber optic cable, the fiber optic cable including an armor tape.

10

45. The optical tube assembly of claim 32, wherein the at least one optical waveguide comprises a portion of a ribbon stack having at least one corner optical waveguide, the at least corner optical waveguide having a MAC number of about
15 7.35 or less.

46. An optical tube assembly comprising:

a tube;

at least one optical waveguide, the optical waveguide
20 being disposed in the tube;

at least one dry insert, the at least one dry insert having a first layer, a second layer, and a plurality of water-swappable filaments, the first and second layers being attached together at least along the longitudinal edges
25 thereof, thereby forming at least one compartment between the first and second layers, wherein the plurality of water-swappable filaments are generally disposed in the at least one compartment, wherein the at least one dry insert is disposed within the tube and generally surrounds the at least one
30 optical waveguide.

47. The optical tube assembly of claim 46, wherein the dry insert comprises a plurality of compartments.

48. The optical tube assembly of claim 46, wherein the at least one optical waveguide comprises a portion of a fiber optic ribbon.

49. The optical tube assembly of claim 46, wherein the at least one optical waveguide has a normalized pull-out force between about 0.5 N/m and about 5.0 N/m.

5

50. The optical tube assembly of claim 46, wherein the at least one optical waveguide has a normalized pull-out force between about 1 N/m and about 4 N/m.

10

51. The optical tube assembly of claim 46, wherein the at least one optical waveguide comprises a portion of a ribbon, the ribbon having a normalized ribbon pull-out force between about 0.5 N/m and about 5.0 N/m.

15

52. The optical tube assembly of claim 46, wherein the ribbon has a normalized ribbon pull-out force between about 1 N/m and about 4 N/m.

20

53. The optical tube assembly of claim 46, wherein the at least one dry insert has a maximum uncompressed height H of about 5 mm or less.

25

54. The optical tube assembly of claim 46, wherein the optical tube assembly comprises a portion of a fiber optic cable.

30

55. The optical tube assembly of claim 46, wherein the fiber optic cable has a normalized ribbon coupling force between about 0.5 N/m and about 5 N/m.

56. The optical tube assembly of claim 46, wherein the optical tube assembly comprises a portion of a fiber optic cable, the fiber optic cable including an armor tape.

57. The optical tube assembly of claim 46, wherein the at least one optical waveguide comprises a portion of a ribbon stack having at least one corner optical waveguide, the at least corner optical waveguide having a MAC number of about 5 7.35 or less.

58. A tubeless fiber optic cable, comprising:
at least one optical waveguide;
at least one dry insert, the dry insert generally
10 surrounding the at least one optical waveguide, wherein the at least one optical waveguide has a normalized pull-out force between about 0.5 N/m and about 5.0 N/m;
a cable jacket, the cable jacket generally surrounding the at least one optical waveguide and the at least one dry
15 insert.

59. The tubeless fiber optic cable of claim 58, the dry layer comprising a felt having having a height of about 0.5 mm or more and including at least one type of non-continuous
20 filament.

60. The tubeless fiber optic cable of claim 58, the at least one dry insert includes at least two different types of non-continuous filaments.

25

61. The tubeless fiber optic cable of claim 58, the dry insert further including a plurality of water-swellaible filaments.

30 62. The tubeless fiber optic cable of claim 61, the plurality of water-swellaible filament comprising about 25% or less, by weight, of the dry insert.

63. The tubeless fiber optic cable of claim 58, the dry
35 insert further comprising a first layer and a second layer.

64. The tubeless fiber optic cable of claim 58, the dry insert having a foam layer and a water-swellaable layer.

65. The tubeless fiber optic cable of claim 58, the dry
5 insert being continuous along the longitudinal length of the cable.

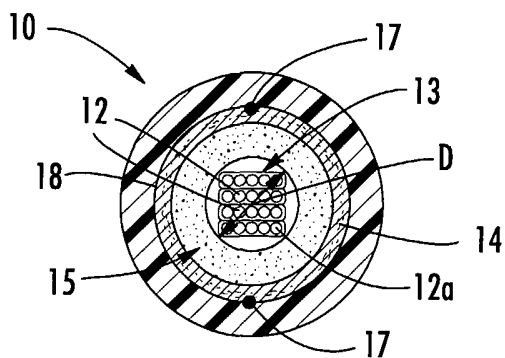

FIG. 1

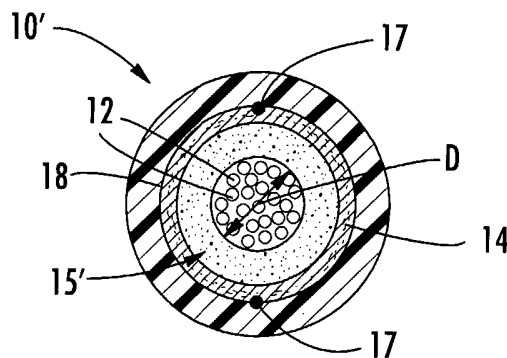

FIG. 1a

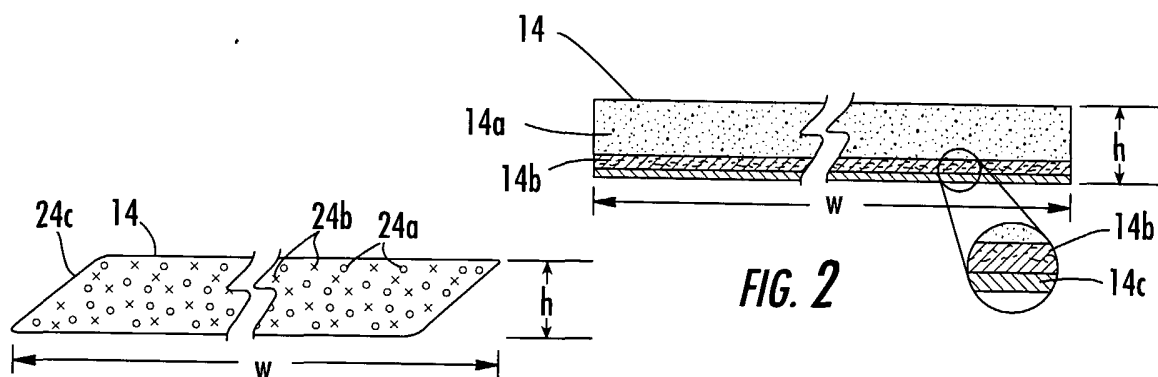

FIG. 2a

FIG. 2

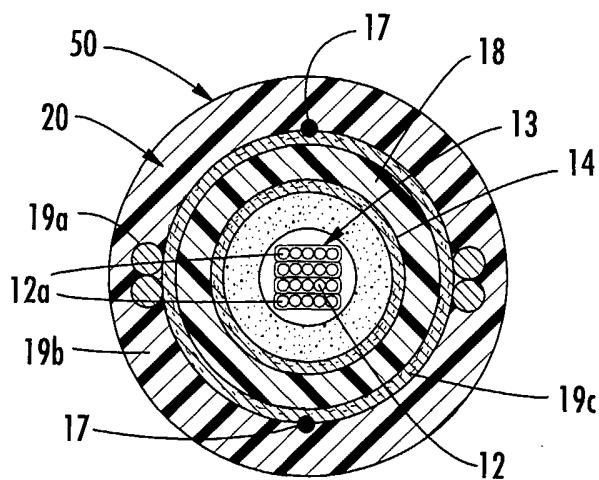

FIG. 5

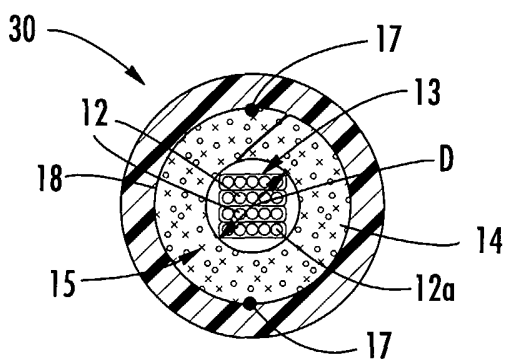

FIG. 3

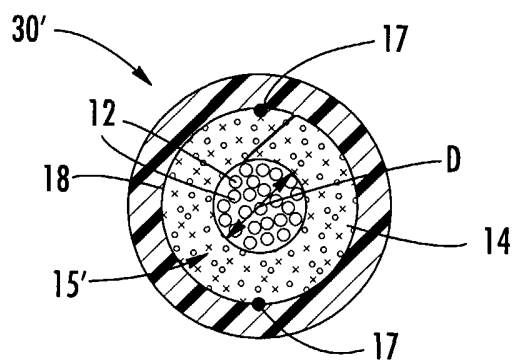

FIG. 3a

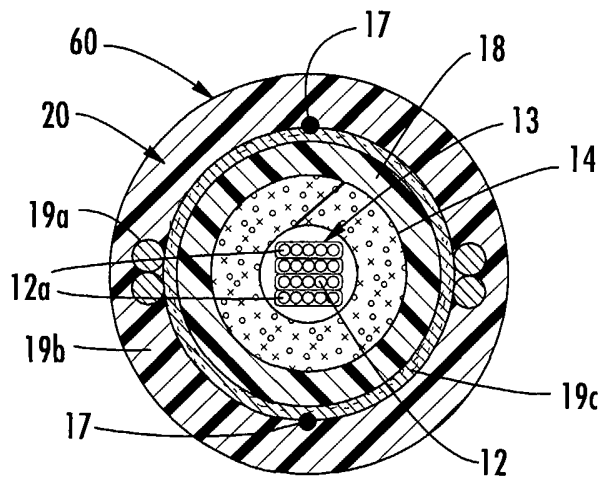

FIG. 6

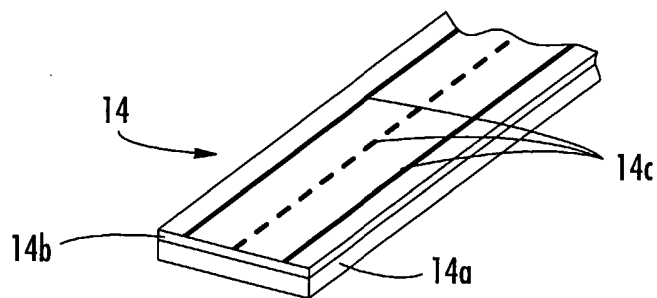

FIG. 2b

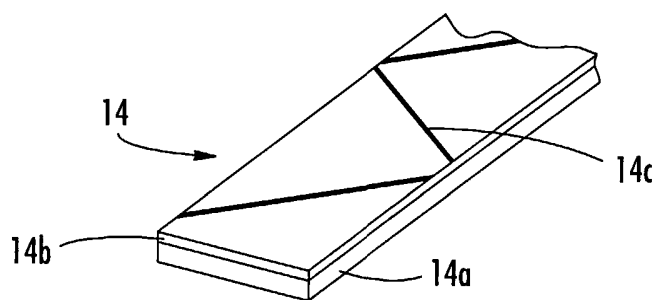

FIG. 2c

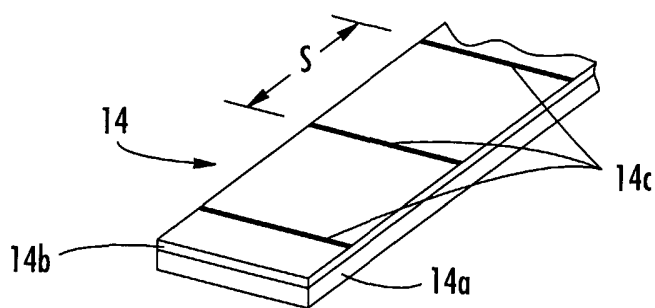

FIG. 2d

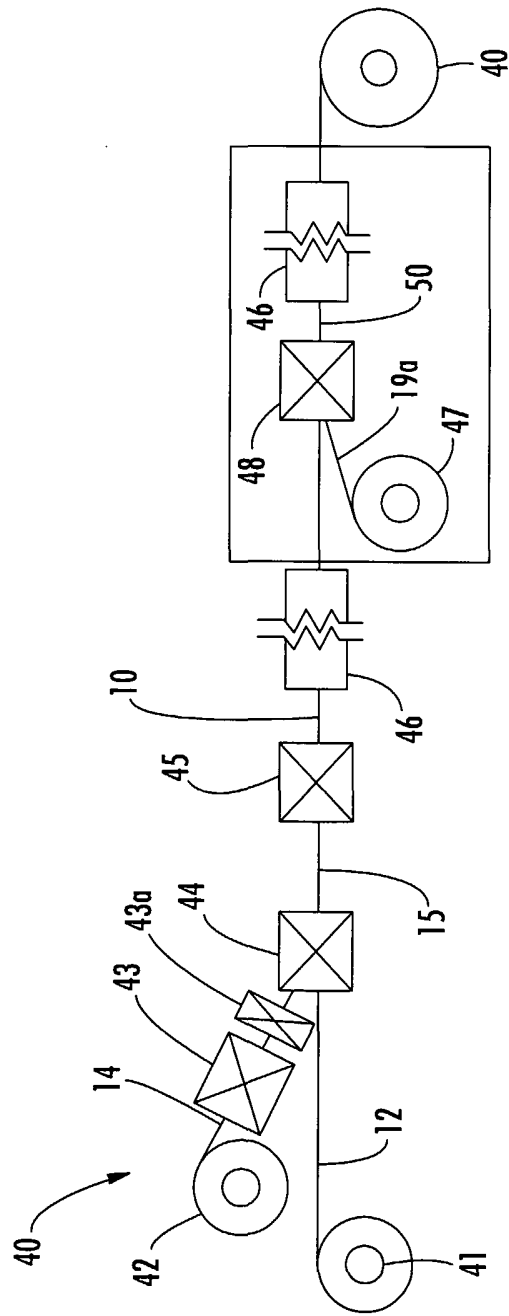

FIG. 4

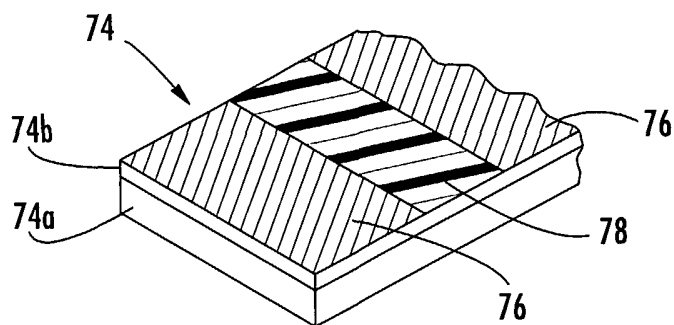

FIG. 7

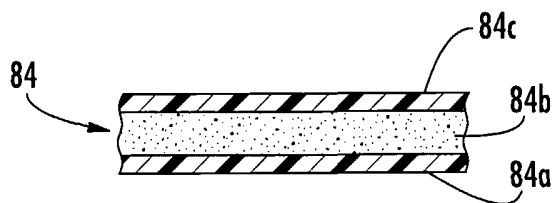

FIG. 8

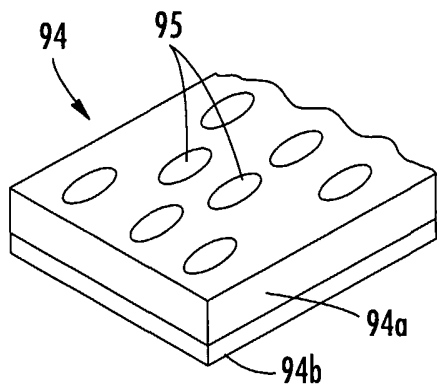

FIG. 9

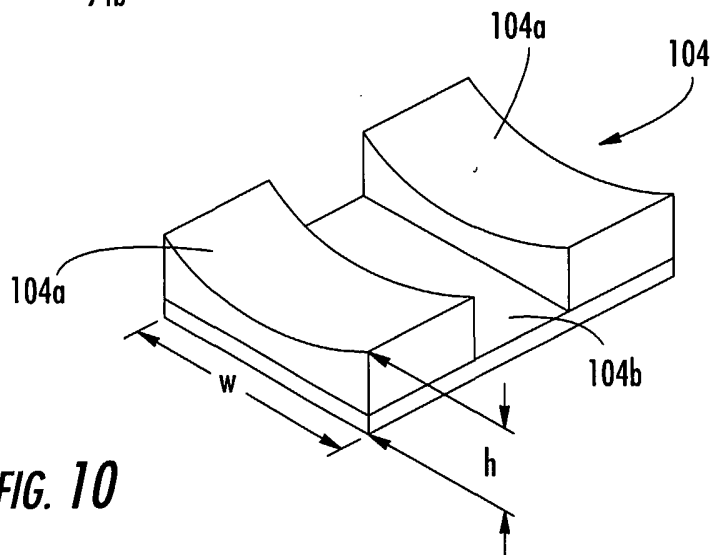

FIG. 10

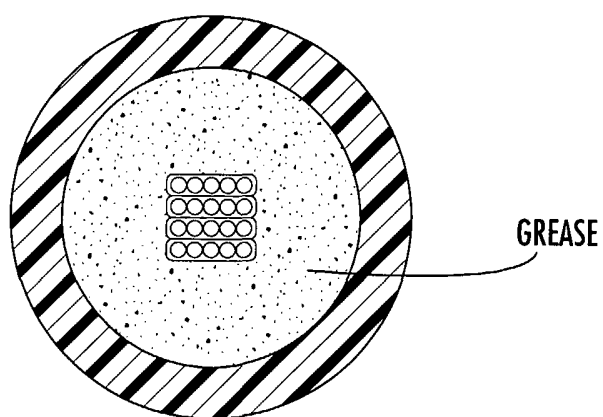

FIG. 11
(PRIOR ART)

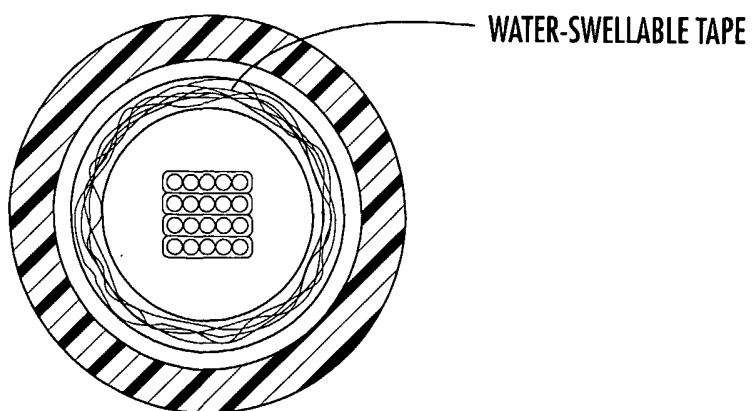

FIG. 12
(PRIOR ART)

7/9

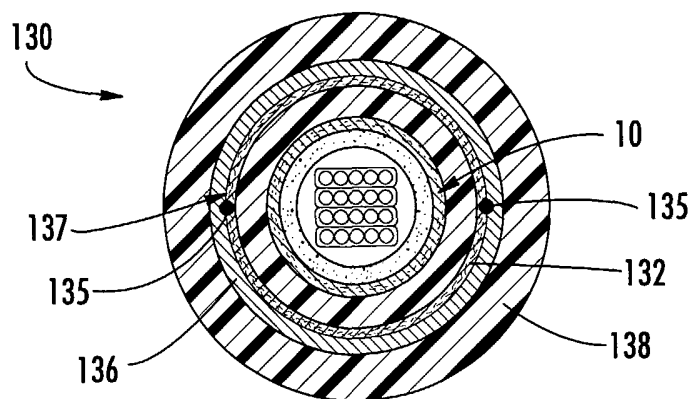

FIG. 13

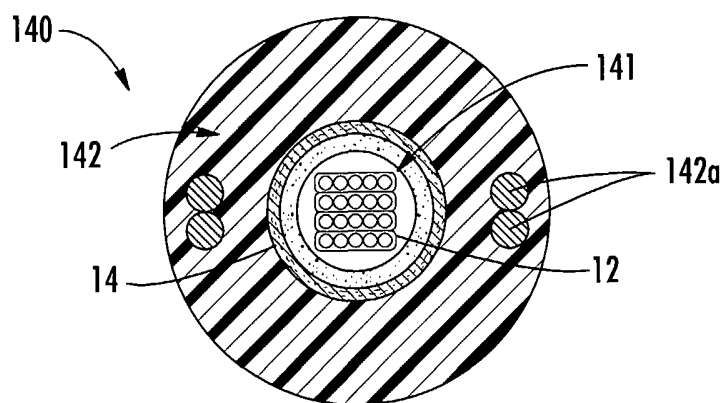

FIG. 14

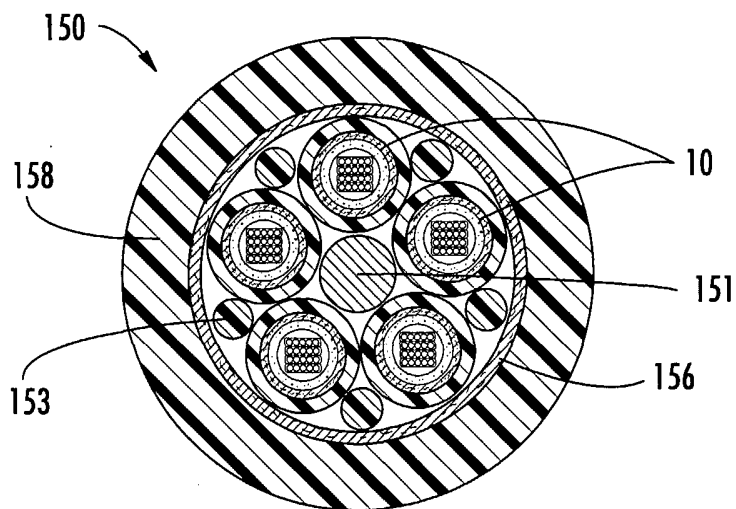

FIG. 15

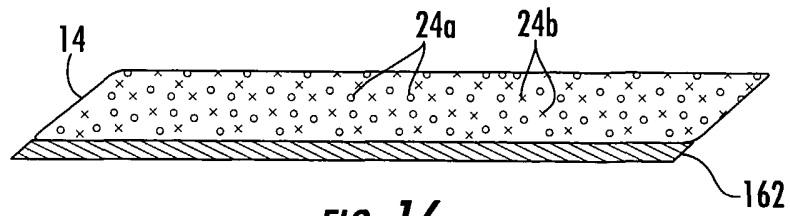

FIG. 16

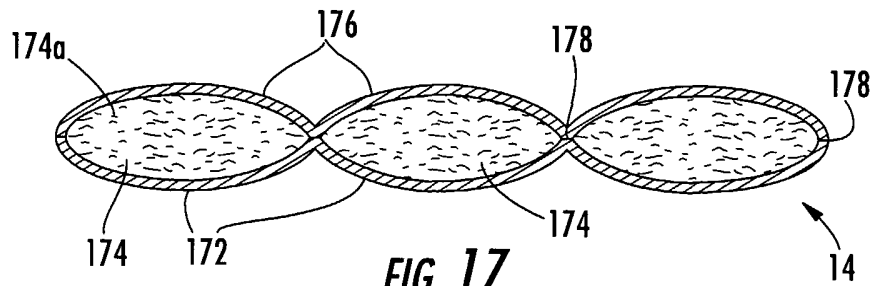

FIG. 17

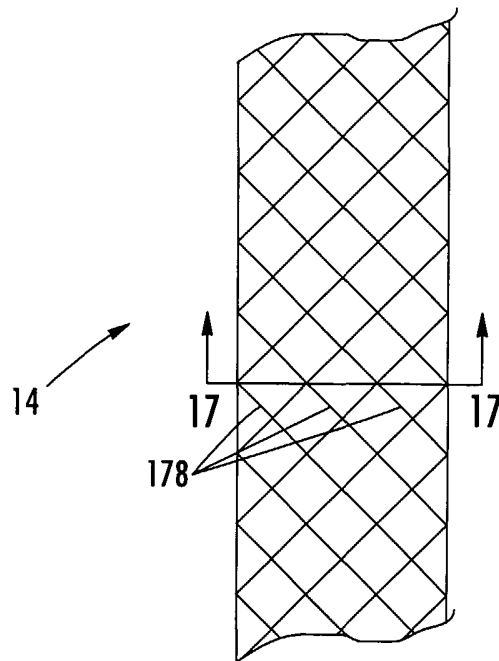

FIG. 18

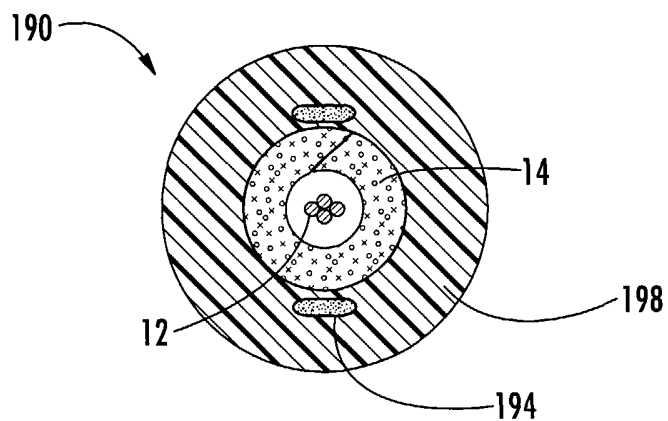

FIG. 19

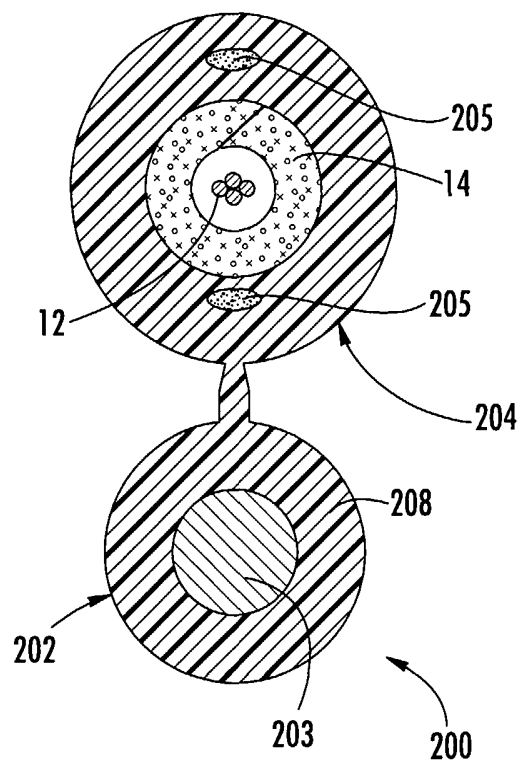

FIG. 20

INTERNATIONAL SEARCH REPORT

International application No.

PCT/US04/22237

A. CLASSIFICATION OF SUBJECT MATTER

IPC(7) : G02B 6/44
 US CL : 385/100, 102, 106, 108, 109

According to International Patent Classification (IPC) or to both national classification and IPC

B. FIELDS SEARCHED

Minimum documentation searched (classification system followed by classification symbols)
 U.S. : 385/100, 102, 106, 108, 109

Documentation searched other than minimum documentation to the extent that such documents are included in the fields searched
 None

Electronic data base consulted during the international search (name of data base and, where practicable, search terms used)
 None

C. DOCUMENTS CONSIDERED TO BE RELEVANT

Category *	Citation of document, with indication, where appropriate, of the relevant passages	Relevant to claim No.
A	US 4,909,592 A (ARROYO et al) 20 March 1990 (20.03.1990), see entire document.	1-65
A	US 6,122,424 A (BRINGUIER) 19 September 2000 (19.09.2000), see entire document.	1-65
Y	US 6,389,204 B1 (HURLEY) 14 May 2002 (14.05.2002), see column 6, lines 20-29.	1-45 and 58-65
A	US 6,574,400 B1 (LAIL) 03 June 2003 (03.06.2003), see entire document.	1-65
Y	US 6,711,329 B2 (ZELESNIK) 23 March 2004 (23.03.2004), columns 3 and 4.	1-45 and 58-65

Further documents are listed in the continuation of Box C.

See patent family annex.

* Special categories of cited documents:	"T"
"A" document defining the general state of the art which is not considered to be of particular relevance	later document published after the international filing date or priority date and not in conflict with the application but cited to understand the principle or theory underlying the invention
"E" earlier application or patent published on or after the international filing date	"X" document of particular relevance; the claimed invention cannot be considered novel or cannot be considered to involve an inventive step when the document is taken alone
"L" document which may throw doubts on priority claim(s) or which is cited to establish the publication date of another citation or other special reason (as specified)	"Y" document of particular relevance; the claimed invention cannot be considered to involve an inventive step when the document is combined with one or more other such documents, such combination being obvious to a person skilled in the art
"O" document referring to an oral disclosure, use, exhibition or other means	"&" document member of the same patent family
"P" document published prior to the international filing date but later than the priority date claimed	

Date of the actual completion of the international search
 26 May 2005 (26.05.2005)

Date of mailing of the international search report
11 JUL 2005

Name and mailing address of the ISA/US
 Mail Stop PCT, Attn: ISA/US
 Commissioner for Patents
 P.O. Box 1450
 Alexandria, Virginia 22313-1450
 Facsimile No. (703) 305-3230

Authorized officer
 Tulsidas C Patel *TCP*
James P. Matthews
 Telephone No. (571) 272-1850