

(No Model.)

3 Sheets—Sheet 1.

I. B. KAUFFMAN.  
TRUNK.

No. 527,336.

Patented Oct. 9, 1894.

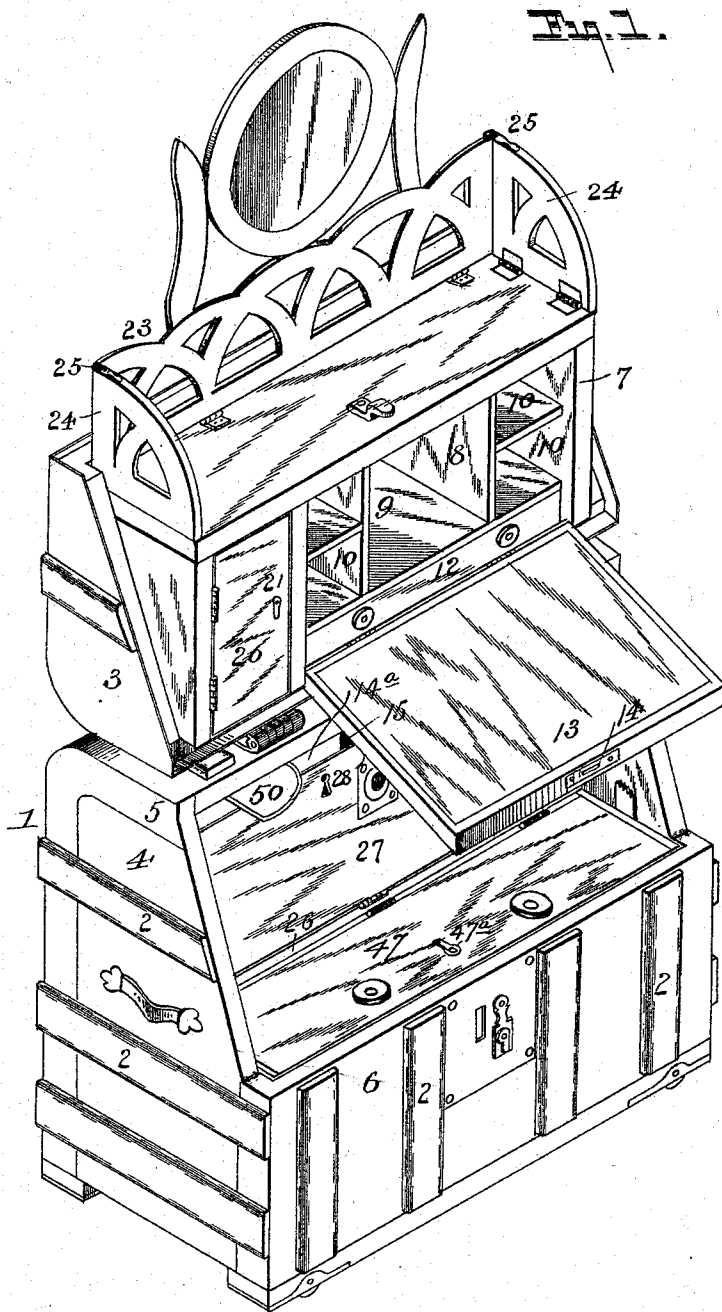

WITNESSES:  
*F. L. Curand*  
*W. L. Bloomer*

INVENTOR:  
*Isaac B. Kauffman*  
*J. S. Patten & Co.*  
Attorneys.

(No Model.)

3 Sheets—Sheet 2.

# I. B. KAUFFMAN. TRUNK.

No. 527,336.

Patented Oct. 9, 1894.

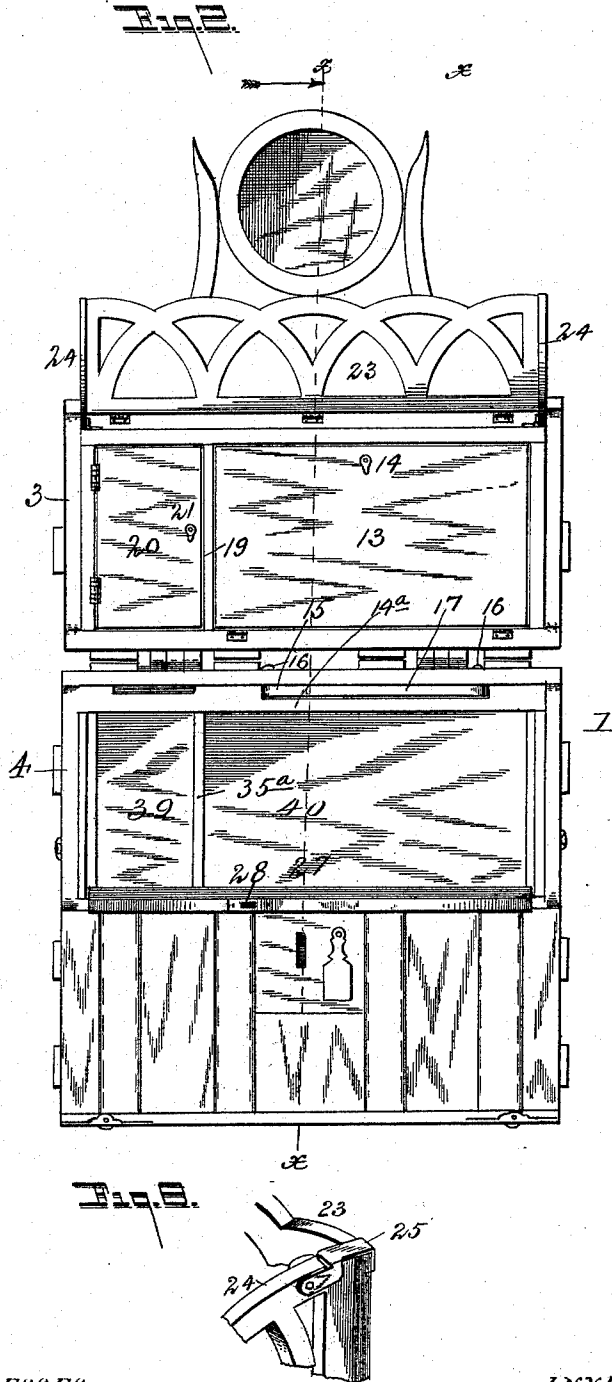

WITNESSES:  
*F. L. Omand.*  
*J. L. Brooks*

INVENTOR:  
*Isaac B. Kauffman,*  
*By James C. Rogers & Co.*  
 Attorneys.

(No Model.)

3 Sheets—Sheet 3.

# I. B. KAUFFMAN. TRUNK.

No. 527,336.

Patented Oct. 9, 1894.

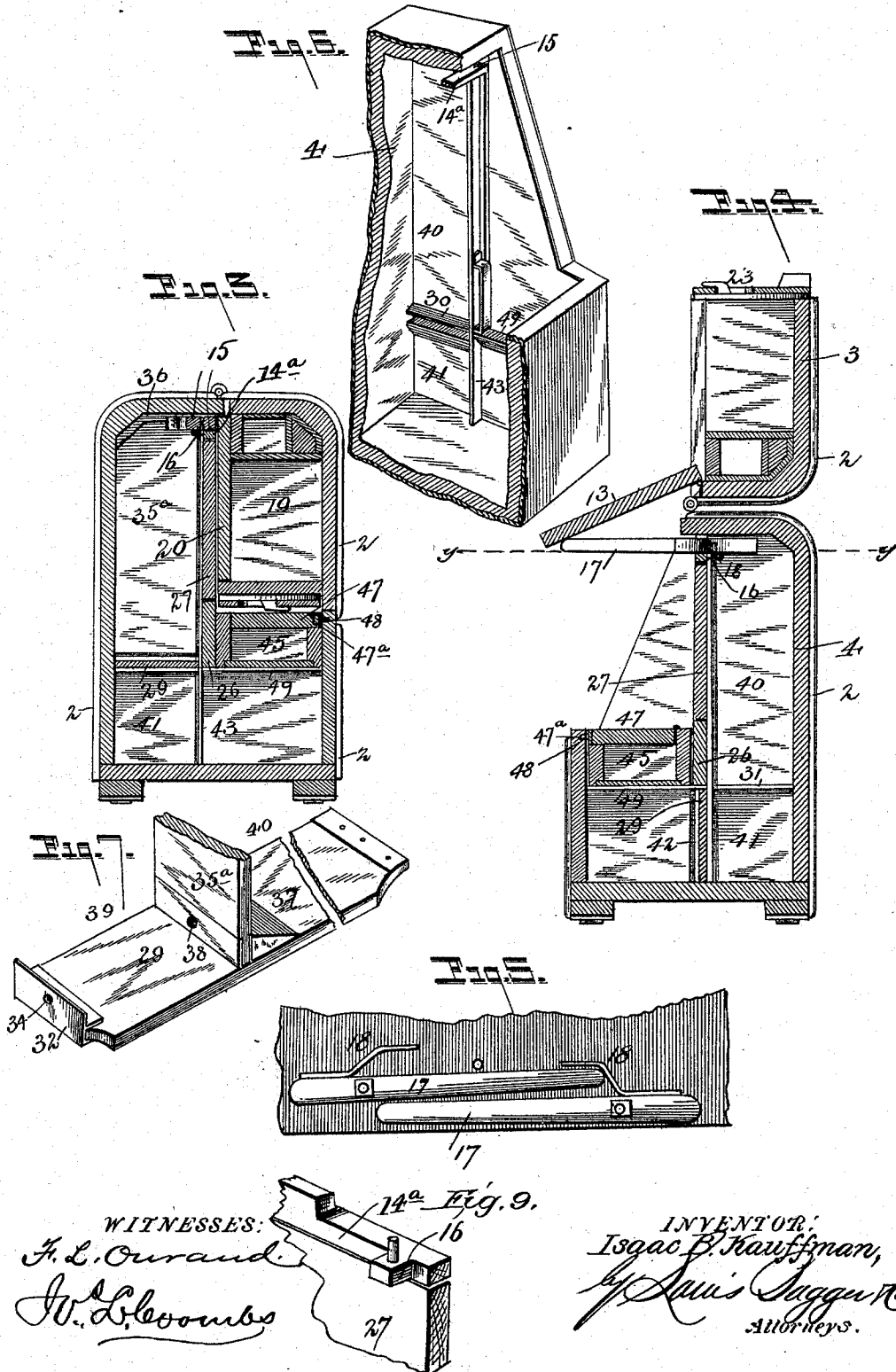

WITNESSES:  
*F. L. Ouraud*  
*W. L. Grooms*

INVENTOR:  
*Isaac B. Kauffman,*  
*by J. S. Suggs & Co.*  
 Attorneys.

# UNITED STATES PATENT OFFICE.

ISAAC B. KAUFFMAN, OF MARBLE HILL, MISSOURI.

## TRUNK.

SPECIFICATION forming part of Letters Patent No. 527,336, dated October 9, 1894.

Application filed April 16, 1894. Serial No. 507,700. (No model.)

### *To all whom it may concern:*

Be it known that I, ISAAC B. KAUFFMAN, a citizen of the United States, and a resident of Marble Hill, in the county of Bollinger and State of Missouri, have invented certain new and useful Improvements in Trunks; and I do hereby declare that the following is a full, clear, and exact description of the invention, which will enable others skilled in the art to which it appertains to make and use the same, reference being had to the accompanying drawings, which form a part of this specification.

My invention relates to improvements in that class of traveling trunks divided in two sections in such manner that one can be swung up upon the top of the other section and be supported thereby, presenting the interior of the trunk to view.

The object of the present invention is to provide a trunk of the above character which shall combine the features of a secretary or writing desk, a bureau and a packing case, and it consists in the novel construction and combination of parts hereinafter fully described and claimed.

In the accompanying drawings: Figure 1 is a perspective view of a trunk constructed in accordance with my invention, one of the sections being swung up on the other, showing the hinged leaf let down and the top rails elevated, forming a writing desk or secretary. Fig. 2 is a front view showing the swinging or movable section open, the writing leaf or shelf closed and the door below the same hinged to the stationary section open. Fig. 3 is a central cross section taken on the line  $x-x$ , in the direction of the arrow. Fig. 4 is a similar view, looking in the opposite direction, with the vertical partition removed and the removable horizontal partition in another position, and with the writing leaf or shelf open or let down and the door below closed. Fig. 5 is a detail plan view showing the pivoted bars which support the leaf. Fig. 6 is a detail perspective view of one end of the trunk looking from the interior thereof. Fig. 7 is a detail perspective view of the removable horizontal partition. Fig. 8 is a detail perspective view of the side rails and their catches. Fig. 9 is a detail perspective view

of the lugs to which the bars which support the leaf are pivoted.

In the said drawings, the reference numeral 1 designates the outside case or box of the trunk, made in the present instance of approximately rectangular form and covered with leather or metal as usual, and provided with strengthening strips 2, as in the ordinary constructions. This box or case is divided into two sections 3 and 4, on an inclined line from the upper side 5, to its front side 6. The upper or movable section 3 is hinged to the lower or stationary section 4, and is provided with a rectangular receptacle 7, divided by means of partitions 8 and 9 into a series of compartments 10, to receive documents, papers, and writing materials. It is also provided with a drawer 12. Hinged to that edge of receptacle 7, which is adjacent to the upper front edge of section 4, is a folding leaf or shelf 13 provided with a lock 14. When this leaf is folded up or closed it forms a door for said receptacle and when let down, serves as a writing leaf. Just below the said upper edge of section 4 is a horizontal strip 14<sup>a</sup> formed with a slot 15, and provided with inwardly extending lugs 16, to which are pivoted bars 17. These bars which serve to support the leaf 13, at their inner ends are provided with flaring arms 18, the object of which will be hereinafter explained. To the left of the writing desk or secretary, formed as above described, is a compartment 19, provided with a hinged door 20, provided with a lock 21. Hinged to that portion of the receptacle 7, which forms the top when the section 3 is opened, is a rear rail 23 and side rails 24. When these rails are elevated into perpendicular positions, as seen in Fig. 1, they serve to prevent books or other objects from falling off of said top. The side rails are provided with spring catches 25, which engage with the horizontal rail, by which they are held in an elevated position. When the section 3 is closed, the rails are folded down on said top.

The lower or stationary section 4, of the trunk, is provided with a central horizontal board or strip 26 to which is hinged a door provided with a lock 28. In rear of this strip 26 is a removable horizontal partition 29, one

end of which fits into a grooved cleat 30 secured to one side of the said section, while the other end rests upon a strip 31 secured to the opposite side. This end of the partition is provided with a flange 32, which is provided with a hole 34 for the passage of a screw 35 by which the partition is held in place. Near one end of said section is a removable vertical partition 35<sup>a</sup> the lower end of which rests upon the partition 29, while its upper end rests in a groove in a cleat 36, secured to the upper part of the section 4. The partition 29 is provided with a strip 37, against which the partition 35<sup>a</sup> abuts, and the latter is held in place by means of a screw 38 passing through its lower end into said strip. There are thus formed two compartments 39 and 40 at the rear of the trunk, and a compartment 41 at the bottom. At one side of the case or box is a vertical grooved cleat 42, and at the opposite side a vertical strip 43. By removing the partition 29, as hereinafter described, and placing it on edge with one end in said groove, and the other end resting against the strip 43, the size of the compartment in the bottom is decreased, while compartments 40 and 41, are thrown together forming a single compartment extending from top to bottom of the trunk for receiving large objects or articles.

Between the strip or board 26, and the front of the trunk, is a removable tray 45, consisting of a rectangular box, provided with a hinged cover 47, provided with a lock 47<sup>a</sup> the bolt of which extends through an aperture 48 in the front thereof, and projects into a slot in the front of the trunk, so that said bolt not only serves to lock the cover, but also prevents the tray from being removed until the bolt is withdrawn or unlocked. This tray rests upon and is supported by strips 49, secured to the sides of the trunk.

The numeral 50 designates a pivoted shelf, which serves to support an ink-stand when the writing desk is in use.

The operation of the invention will be readily understood. When it is desired to use the trunk as a writing-desk, the section 3 is unlocked and swung up onto section 4. The bars 17 are then turned outwardly on their pivots, so as to extend outwardly at right angles to the said section and serve as supports for the leaf 13, which is unlocked and

let down. It will be noted that the flaring arms 18, of one bar, will strike the other bar when said first-mentioned bar is pulled out and thus force it out also. These bars overlap each other when pushed in and no matter which one is pulled out, the other will be forced out with it by means of the arms. The top of the section 3, serves as a shelf or book support. When the writing desk is not in use, the leaf 13, is folded up and locked. The lower section 4 serves as a receptacle for clothes and other articles, the compartments 39, 40, and 41, being especially applicable for such purposes, while the removable tray is adapted to receive toilet articles.

When a large space is required to receive bulky articles, the vertical and horizontal partitions 29 and 35<sup>a</sup> are removed by first withdrawing the screws and disengaging the ends from the grooves, and partition 29 is set on edge with one end resting in the vertical groove 42, and the other end resting against the strip 43, so that a compartment will be formed at the rear of the trunk extending from the top to the bottom thereof.

Having thus described my invention, what I claim is—

1. In a trunk of the character described, the combination with the lower section having a horizontal strip with a slot, the inwardly extending lugs and the pivoted supporting bars, having the flaring arms, of the upper hinged section, divided into compartments and the hinged writing leaf, substantially as set forth.

2. In a trunk of the character described, the combination with the hinged section adapted to serve as a writing desk, the lower stationary section having a horizontal partition, the door hinged thereto, the removable horizontal and vertical partitions, the grooved cleats and strips and the retaining screws, of the removable tray having a lock the bolt of which is adapted to project through an aperture in the front thereof, and engages with a slot in the front of the said lower section, substantially as and for the purpose set forth.

In testimony that I claim the foregoing as my own I have hereunto affixed my signature in presence of two witnesses.

ISAAC B. KAUFFMAN.

Witnesses:

A. J. BEDWELL,  
HERMAN ULRICH.