

No. 677,727.

Patented July 2, 1901.

W. I. WHITEHURST.  
SHUTTLE FOR WIRE WEAVING LOOMS.

(Application filed Oct. 29, 1900.)

(No Model.)

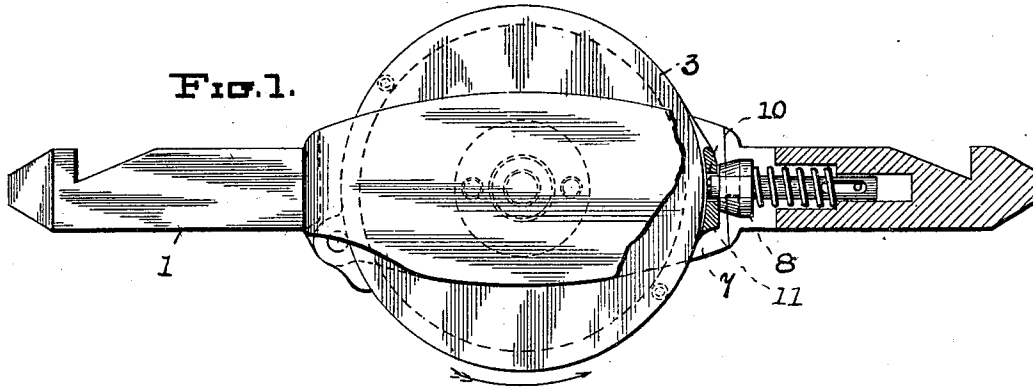

FIG. 1.

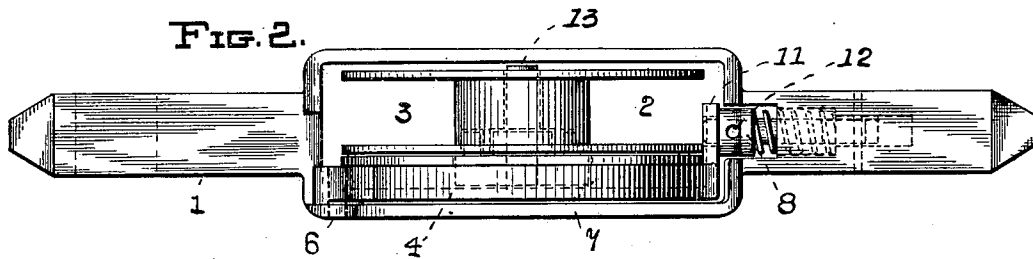

FIG. 2.

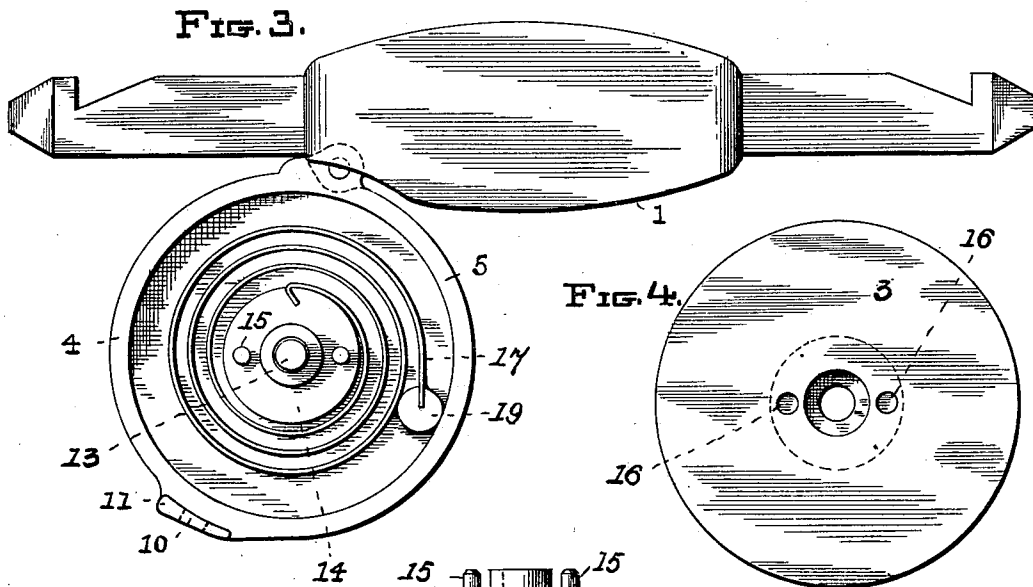
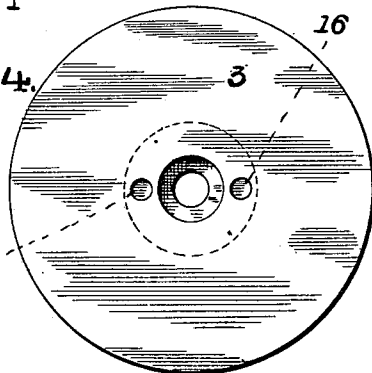

FIG. 3.

FIG. 4.



WITNESSES:—

*A. O. Babendrius*  
*Osip J. Gots*



FIG. 5.

INVENTOR:—

*Walter J. Whitehurst*  
by *Wm. H. T. Howard*  
*Atty.*

# UNITED STATES PATENT OFFICE.

WALTER I. WHITEHURST, OF BALTIMORE, MARYLAND.

## SHUTTLE FOR WIRE-WEAVING LOOMS.

SPECIFICATION forming part of Letters Patent No. 677,727, dated July 2, 1901.

Application filed October 29, 1900. Serial No. 34,740. (No model.)

*To all whom it may concern:*

Be it known that I, WALTER I. WHITEHURST, of the city of Baltimore, in the State of Maryland, have invented certain Improvements in Shuttles for Wire-Weaving Looms, of which the following is a specification.

This invention relates, first, to certain improvements in the tension devices which in common with others of its class are designed to take up the loop formed in the wire delivered from the bobbin as the shuttle is reversed in direction of movement.

The said invention relates, secondly, to means whereby an exhausted bobbin may be easily and readily removed from the shuttle and a filled one substituted therefor, as will hereinafter fully appear.

In the further description of the said invention which follows reference is made to the accompanying drawings, forming a part hereof, and in which—

Figure 1 is a partly-sectional top view of a shuttle embodying the present invention. Fig. 2 is an exterior side view of the same. Fig. 3 is a view similar to Fig. 1, except that the bobbin-holder and bobbin are shown as swung to a position exterior of the remaining parts of the shuttle and one which admits of the removal of the bobbin. Fig. 4 is an under side view of the bobbin. Fig. 5 is a side view of a part of the shuttle.

Referring now to the drawings, 1 is the shuttle, having the usual opening 2 for the reception of the bobbin 3.

4 is a circular dished bobbin-holder the flange 5 of which is pivoted to a lug 6, projecting from the lower plate 7 of the shuttle proper. By this construction the pivoted bobbin-holder may be swung from its normal position (shown in Figs. 1 and 2) to the position illustrated in Fig. 3, in order to allow of the substitution of a filled bobbin for an exhausted one. The bobbin-holder is secured when in its normal position by means of a spring-held bolt 8, the point of which enters the hole 10 in a lug 11, projecting upward from the flange 5. To unlock the bobbin-holder, a pointed instrument is inserted in the hole 12 and the bolt pushed back from contact with the holder.

13 is a fixed pintle or pin projecting up-

wardly from the bottom of the bobbin-holder 4, about which the bobbin rotates.

The bobbin 3 is seated loosely on a hub 14, adapted to rotate freely about the pintle 13, and in order that the holder and hub may rotate together the latter is provided with two pins 15, which enter holes 16 in the under side of the former.

17 is a partially-wound coiled spring, one end of which is free and provided with a friction-disk 19, which bears against the inner surface of the flange 5 of the bobbin-holder, as shown in Fig. 3. The other end of this spring is attached to the hub 14, and consequently indirectly to the bobbin 3.

The operation of the invention is as follows: In what might be termed the "forward" movement of the shuttle the bobbin is rotated in the direction represented by the curved arrow in Fig. 1, and in view of the friction between the disk 19 and the inner surface of the flange 5 the said spring is further wound. The winding of the spring places a certain tension on the wire wound on the bobbin, and as the shuttle completes its forward stroke and begins to return the bobbin is rotated in an opposite direction by the unwinding of the coiled spring to the extent required to take up any slack in the wire effected by the overdelivery of the wire from the bobbin consequent upon its rotation not being stopped coincident with the stoppage of the shuttle proper and also from the change in the direction of lead of the wire. When the bobbin is exhausted of its wire, the spring-held bolt is pushed back and the bobbin-holder, with its exhausted bobbin, swung outward and the bobbin removed and a filled one substituted therefor.

It will be understood that in the change of the bobbins no part other than the bobbin itself is detached from the shuttle proper, and consequently much time is saved in the changing operation.

I claim as my invention—

1. In a shuttle, the combination of a removable bobbin, a flanged bobbin-holder carrying a central pintle for the bobbin, a hub adapted to rotate loosely about the central pintle with means to connect it with the bobbin, and a coiled spring, one end of which is

attached to the said hub, and the other end free and provided with a frictional device which bears against the inner surface of the said bobbin-holder, substantially as specified.

5 2. In a shuttle, the combination of a flanged bobbin-holder carrying a central pintle for the bobbin, a hub adapted to rotate loosely about the central pintle having pins which enter the under side of the bobbin, and

a coiled spring one end of which is attached 10 to the said hub, and the other free and provided with a friction-disk which bears against the inner peripheral surface of the bobbin-holder, substantially as specified.

WALTER I. WHITEHURST.

Witnesses:

OREGON MILTON DENNIS,  
ESTEP T. GOTT.