

(19) **DANMARK**

(10) **DK/EP 3635182 T3**



Patent- og
Varemærkestyrelsen

(12) **Oversættelse af
europæisk patentskrift**

-
- (51) Int.Cl.: **E 02 F 3/92 (2006.01)**
- (45) Oversættelsen bekendtgjort den: **2022-01-17**
- (80) Dato for Den Europæiske Patentmyndigheds bekendtgørelse om meddelelse af patentet: **2021-10-20**
- (86) Europæisk ansøgning nr.: **18731227.7**
- (86) Europæisk indleveringsdag: **2018-05-31**
- (87) Den europæiske ansøgnings publiceringsdag: **2020-04-15**
- (86) International ansøgning nr.: **NL2018050356**
- (87) Internationalt publikationsnr.: **WO2018222039**
- (30) Prioritet: **2017-05-31 NL 2019004**
- (84) Designerede stater: **AL AT BE BG CH CY CZ DE DK EE ES FI FR GB GR HR HU IE IS IT LI LT LU LV MC MK MT NL NO PL PT RO RS SE SI SK SM TR**
- (73) Patenthaver: **Dredge Yard DMCC, Goldcrest Executive Tower , Office No. 308 , Cluster C , Jumeirah Lakes Towers, Dubai, Forenede Arabiske Emirater**
- (72) Opfinder: **YOUSEF, Basel, Weena 750, 3014 DA Rotterdam, Holland**
- (74) Fuldmægtig i Danmark: **Plougmann Vingtoft A/S, Strandvejen 70, 2900 Hellerup, Danmark**
- (54) Benævnelse: **SKÆREHOVED MED SUGEFUNKTION OG EN FREMGANGSMÅDE TIL ANVENDELSE DERAFF**
- (56) Fremdragne publikationer:
WO-A1-2011/053624
WO-A1-2014/007634
WO-A1-2015/126247
CN-A- 104 196 076

DESCRIPTION

[0001] The present invention relates to a cutter head according to the preamble of claim 1. According to another aspect, the invention also relates to a method for using said cutter head according to claim 10.

[0002] It is commonly known in the art to use cutter heads for dredging purposes. The cutter head is used solely for cutting the water bottom. A separate pump, or a plurality thereof, is provided for pumping away the mixture of solid material and water. Dutch patent application NL1012795 and US patent application US2002/0104238 both relate to such cutter head arrangements.

[0003] Such known set up has a disadvantage in that the suction action is insufficient if the pump is positioned away too far from the cutter head. Positioning the pump close to the cutter head is no option, since the pump preferably is positioned above water level. Document WO 2014/007634 A1 discloses the closest prior art.

[0004] Tendency of most manufacturers is to apply stronger pumps which increases costs.

[0005] The invention aims at providing an improved cutter head of the kind mentioned in the preamble.

[0006] The invention further aims at providing a cutter head that at least partly eliminates the need for pumps.

[0007] So as to obtain at least one of the above mentioned aims, the invention provides a cutter head comprising the features of claim 1. This cutter head has the advantage that a high pumping action is obtained. As a consequence, a pump for transporting the mixture of solid material and water may have a smaller capacity than is required with known cutter heads or may be omitted completely.

[0008] It has shown that the cutter head according to the present invention is able to remove substantially all solid material that has been cut loose by the cutter head. Virtually no material is lost. Such synergistic effect is surprising and highly advantageous.

[0009] The invention therefore relates to a cutter head for removing a mixture comprising water and solid materials from a water bottom, comprising rotating blades each provided with cutting means on a leading edge thereof, said cutter head being rotatably coupled to a tube for transporting said mixture, the shape of the leading edge of said rotating blades being defined by substantially fitting a rounded cone with a rotation axis, wherein each rotating blade at a middle part is coupled to a connecting ring and at a top part is linked to a top part of another rotating blade. The cutter head is characterized in that the rotation axis of said blades is substantially aligned with a rotation axis of said ring; further characterized in that a trailing edge

of part at least one of said blades is positioned closer to said rotation axis than a leading edge of said blades so as to provide a suction function towards said tube upon rotation of said cutter head; and still further characterized in that said blades as viewed from said top part at a bottom part of said blades extend to a position beyond said connecting ring and are positioned partly inside the tube. An additional effect of the cutter head according to the invention is obtained by the said positioning of the trailing edge relatively close to the rotation axis, providing a radial motion to the mixture of solid materials and the water such that said mixture is directed towards the tube. Actually, the action of the blades of the cutter head may be compared with the action of blades of a propeller.

[0010] More in particular, due to the fact that the rotating blades extend to a position beyond the connecting ring and as such are positioned partly inside the tube, the mixture of water and solid material is more effectively guided into the tube at a higher velocity so that the solid materials do not fall back towards the cutter head. Clogging is thus effectively prevented. Providing a restriction in the tube close to the cutter head further enhances the transport of the solid material and water into the tube. The restriction may be a venturi-like narrowing. Since the cutter head itself induces a velocity increase to the mixture of solid material and water said mixture automatically follows such venturi shaped narrowing in the tube. A technical designer is easily capable of positioning said narrowing at a correct position in the tube, taking account of the velocity the mixture is transported and the nature of said mixture.

[0011] So as to obtain a maximum pumping action by said blades, it is preferred that said leading edge of said blades is directed substantially into a rotation direction of said blades. Since the blades of the cutter head are provided with a trailing edge positioned relatively close to the rotation axis, any mixture can only leave the cutter head through said tube, yielding a pressure inside said tube and as a consequence a positive head to the pumping action.

[0012] A smooth operation yielding both a high pumping capacity and an optimum cutting action is obtained when said leading edges of said blades substantially fit said rounded cone. The cutting means then have a good grip on the water bottom to be dredged.

[0013] When using the cutter head according to the present invention, solid material and water are pumped away by the cutter head, more in particular due to the specific shape of the blades, wherein said rotating blades comprise a guiding surface between said leading edge and said trailing edge and directed towards a position between said cone and said rotation axis. As a consequence, the mixture is transported from the water bottom to a position inside the cutter head. Overall, it is preferred for the rotating blades to have a smoothly varying surface between the leading edge and the trailing edge.

[0014] An excellent operation is provided by a cutter head wherein a trailing edge of said blades near said middle part is positioned at a larger distance from said rotation axis than a trailing edge of said blades near said top part. It has shown that a flow path for said solid material and water is highly enhanced by such embodiment, further decreasing the chance of clogging of the cutter head.

[0015] As an alternative embodiment, in the cutter head according to the invention, a trailing edge of said blades near said middle part is positioned at a larger distance from said rotation axis than a trailing edge of said blades near said bottom part.

[0016] According to the invention, an efficient pumping action is especially obtained by a cutter head wherein a trailing edge of at least one of said blades at a position near said middle part is positioned closer to said rotation axis than a leading edge of at least one of said blades at a position closer to said top part.

[0017] A strong and solid cutter head is obtained when said connecting ring and said tube are connected and mutually rotatably driven. Usually, the connecting ring is coupled to an end of said tube, such that the rotating blades are partly positioned inside said tube.

[0018] A sturdy cutter head consists of a set of blades, each blade being connected to said connecting ring and wherein said connecting ring is coupled to the tube, said tube being driven by means of a coaxial motor positioned at an outside of said tube.

[0019] According to a further aspect, the invention relates to a method of dredging a water bottom by using a cutter head according to the invention as mentioned above, said method comprising the steps of positioning said cutter head on said water bottom, and rotatably driving a mutually connected tube and said cutter head so as to cut the water bottom and pumping an obtained mixture of solids and water through said tube. The effects and advantages that are obtained with a cutter head as mentioned above can be obtained with this method.

[0020] Hereafter, the invention will be further described by means of a drawing. The drawing shows in:

Fig. 1 a partially sectional side view of a cutter head according to the invention;

Fig. 2 shows a perspective bottom view of the cutter head according to Fig. 1; and

Fig. 2 shows a top view of the cutter head according to Fig. 1.

[0021] The same and similar parts and features of the cutter head according to the present invention have been denoted by the same reference numerals in the figures. However, for ease of understanding the figures, not all parts that are required for a practical embodiment have been shown.

[0022] Fig. 1 shows a partially sectional side view of a cutter head 1 for dredging purposes and the like in a water bottom. The cutter head 1 comprises blades 2 to which cutting means 3 are provided for cutting the water bottom. During use, the cutter head 1 is rotated along rotation axis 4 so as to consecutively cut the water bottom by means of said cutting means 3. Generally, cutter heads 1 as shown in the figure are used in dredging for removing sand, rocks

and the like from a water bottom. Therefore, a mixture of solid materials and water is obtained, that must be removed from said water bottom.

[0023] The blades 2 in the cutter head 1 according to the present invention are embodied somewhat helicoid. A plurality of blades 2 is provided, positioned symmetrically around a rotation axis 4. Each only covers part of a circle if viewed from a position on its rotation axis 4, as schematically shown in Fig. 2. Preferably, each blade 2 is embodied with a rake and skew. As a consequence, the blades 2 are mutually coupled at a first position 5 close to the rotation axis 4, whereas at a second position 6 each blade 2 is connected to a rim 7 (in this description also mentioned connecting ring 7), said second position 6 being further away from the rotation axis 4.

[0024] In between said two positions 5, 6, each blade 2 provides a pumping action upon rotation of the cutter head 1, said pumping action being dependent on the rate of rake and skew, the diameter of the blades 2 and the rotational velocity of the cutter head 1.

[0025] The blades 2 are coupled to a tube 8, preferably through said rim 7. A rotation axis 9 of said tube 8 is aligned with the rotation axis 4 of said set of blades 2.

[0026] Due to the shape of the blades 2, a pumping action is obtained upon rotation of the blades 2. A leading edge 10 is directed into the rotational direction of the cutter head 1 whereas the blades 2 are shaped such that a trailing edge 11 is directing to and situated in a location inside the circumference of the rim 7 of the cutter head 1. As a matter of fact, the trailing edge 11 of each blade is located closer to the rotation axis 4 than the leading edge 10 at a same distance from the rim 7. The blade 2 may bend progressively from the leading edge 10 towards the trailing edge 11, but a uniform bending is possible as well. The pumping action induced by the blades 2 on the mixture of water and solids is dependent on such shape of the blades 2. Furthermore, due to the shape of the blades 2, mixture of water and solid materials is directed towards the inside of the cutter head 1 and therefore directly towards the tube 8, such that all mixture will be transported efficiently. As a consequence, the pumping head provided by the shape of the blades 2 of the cutter head 1 work together with the propelling action of the said blades 2 such that a most efficient effect is obtained. It has shown that the pumping head provided by the cutter head of the present invention may increase significantly. This relieves the regular pump or may even allow shutting off the regular pump. A huge advantage is the cost reduction for pumping gear, if compared with the state of the art.

[0027] As shown in Fig. 1, the cutting means 3 are provided on the leading edge 9 of each blade 2.

[0028] As mentioned above, Fig. 1 shows a partly sectional side view of the cutter head 1. The rake and skew of each blade 2 are clearly visible in Fig. 1 and also in Fig. 2 and 3.

[0029] The top view of Fig. 2 clearly shows that the blades 2 are mutually connected at first position 5. A connecting member 13 is provided to which all blades 2 are connected at their

respective top part.

[0030] Fig. 3 clearly shows that part 12 of blades 2 extend to a position beyond the rim 7, if viewed from the first position 5. Part of the blades 2 is placed between said first position 5 and the rim 7 (i.e. second position 6), whereas a remaining part 12 of said blades 2 extend further. It is clear from Fig. 1 that said part 12 is placed inside the tube 8. As a consequence, the mixture of water and solid material is effectively guided into the tube 8. It is not necessary that part 12 also provides a pumping action. It may be sufficient for part 12 to guide said mixture into the tube 8, although some additional pumping action provided by part 12 may help to more effectively transport said dredged mixture.

[0031] The invention is not limited to the embodiments as mentioned above and as shown in the drawings. The invention is limited by the claims only.

[0032] The invention also relates to all combinations of features described here independently of each other.

REFERENCES CITED IN THE DESCRIPTION

Cited references

This list of references cited by the applicant is for the reader's convenience only. It does not form part of the European patent document. Even though great care has been taken in compiling the references, errors or omissions cannot be excluded and the EPO disclaims all liability in this regard.

Patent documents cited in the description

- [NL1012795 \[0002\]](#)
- [US20020104238A \[0002\]](#)
- [WO2014007634A1 \[0003\]](#)

Patentkrav

1. Skærehoved (1) til fjernelse af en blanding omfattende vand og faste materialer fra en vandbund, hvor skærehovedet omfatter roterende klinger (2), som hver er forsynet med skæreorgan (3) på en forkant (10) deraf, idet nævnte 5 skærehoved (1) er roterbart koblet til et rør (8) til transport af nævnte blanding, idet formen af forkanten (10) af nævnte roterende klinger (2) er defineret således, at den i alt væsentligt svarer til en afrundet konus med en rotationsakse (4), hvor hver roterende klinge (2) ved en midterste del (6) er koblet til en forbindelsesring (7), og ved en øvre del (5) er forbundet til en øvre del (5) af en 10 anden roterende klinge (2),
hvor rotationsaksen (4) af nævnte klinger (2) er i alt væsentligt anbragt på linje med en rotationsakse af nævnte ring (7);
hvor en bagkant (11) af en del af mindst en af nævnte klinger (2) er positioneret tættere på nævnte rotationsakse (4) end en forkant (10) af 15 nævnte klinger (2) for at tilvejebringe en sugefunktion mod nævnte rør (8) ved rotation af nævnte skærehoved (1);
- kendetegnet ved, at**
- nævnte klinger (2) set fra nævnte øvre del (5) ved en nedre del af nævnte klinger (2) strækker sig til en position udover nævnte forbindelsesring (7) 20 og er positioneret delvis indeni røret (8).
2. Skærehoved (1) ifølge krav 1, hvor nævnte forkant (10) af nævnte klinger (2) er rettet i alt væsentligt i en rotationsretning af nævnte klinger (2).
- 25 3. Skærehoved (1) ifølge krav 1, hvor nævnte forkanter (10) af nævnte klinger (2) i alt væsentligt passer til nævnte afrundede konus.
4. Skærehoved (1) ifølge krav 1, hvor nævnte roterende klinger (2) omfatter en føringsoverflade mellem nævnte forkant (10) og nævnte bagkant (11) og rettet 30 mod en position mellem nævnte konus og nævnte rotationsakse (4).
5. Skærehoved (1) ifølge krav 1, hvor en bagkant (11) af nævnte klinger (2) tæt på nævnte midterste del (6) er positioneret med en større afstand til nævnte rotationsakse (4) end en bagkant (11) af nævnte klinger (2) tæt på nævnte øvre

del (5).

6. Skærehoved (1) ifølge krav 1, hvor en bagkant (11) af nævnte klinger (2) tæt på nævnte midterste del (6) er positioneret med en større afstand til nævnte 5 rotationsakse (4) end en bagkant (11) af nævnte klinger (2) tæt på nævnte nedre del.

7. Skærehoved (1) ifølge et hvilket som helst af de foregående krav, hvor en bagkant (11) af mindst en af nævnte klinger (2) ved en position tæt på nævnte 10 midterste del (6) er positioneret tættere på nævnte rotationsakse (4) end en forkant (10) af mindst en af nævnte klinger (2) ved en position tættere på nævnte øvre del (5).

8. Skærehoved (1) ifølge et hvilket som helst af de foregående krav, hvor nævnte 15 forbindelsesring (7) og nævnte rør (8) er indbyrdes forbundet og roterbart drevet.

9. Skærehoved (1) ifølge krav 8, hvor nævnte rør (8) drives ved hjælp af en koaksial motor positioneret ved en yderside af nævnte rør (8).

20 **10.** Fremgangsmåde til opmudring af en vandbund under anvendelse af et skærehoved (1) ifølge et hvilket som helst af de foregående krav, idet nævnte fremgangsmåde omfatter trinnene at positionere nævnte skærehoved (1) på nævnte vandbund, og roterbart at drive et indbyrdes forbundet rør (8) og nævnte skærehoved (1) for at skære vandbunden og pumpe en opnået blanding af faste 25 materialer og vand gennem nævnte rør (8).

DRAWINGS

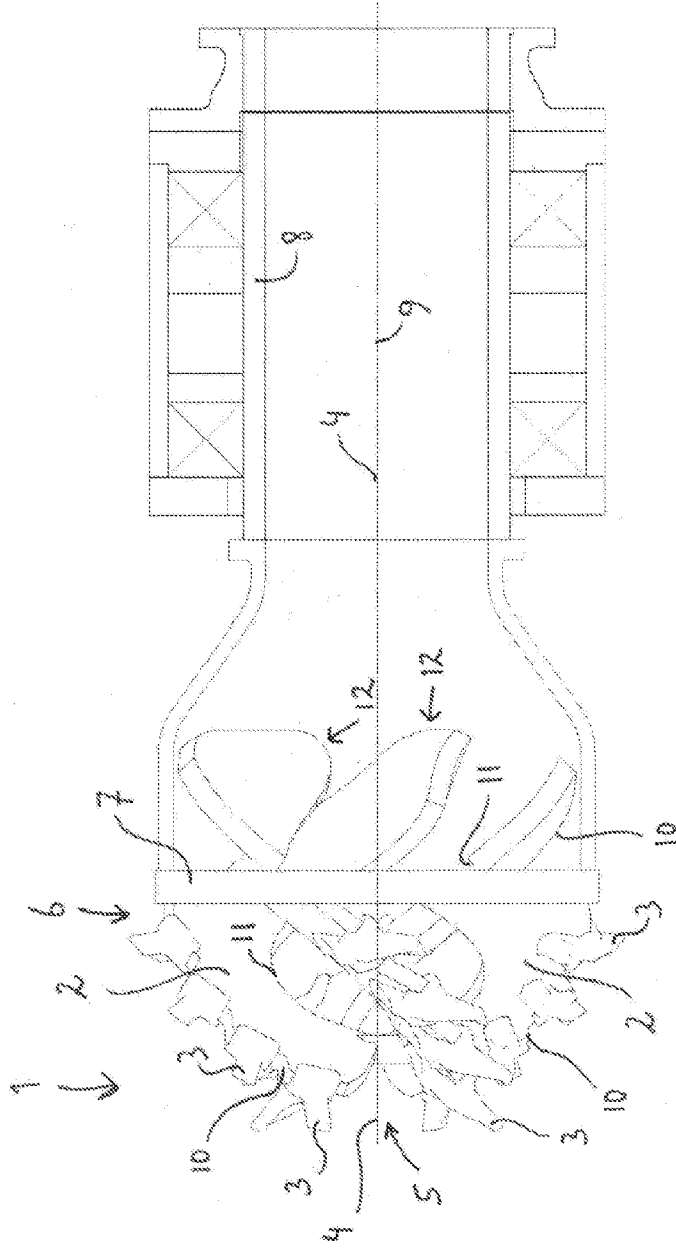

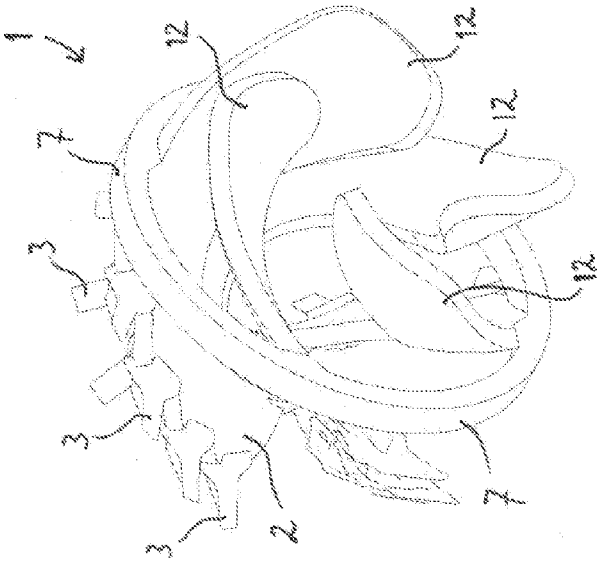

FIG. 3

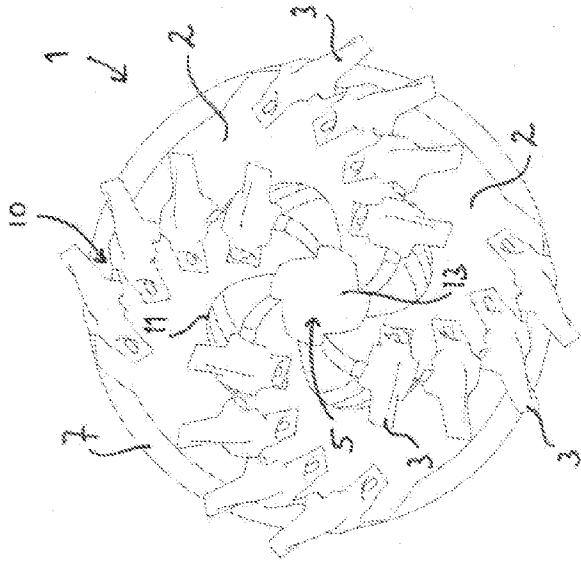

FIG. 2