



INTERNATIONAL APPLICATION PUBLISHED UNDER THE PATENT COOPERATION TREATY (PCT)

<p>(51) International Patent Classification⁶ : C07C 273/04</p>	<p>A1</p>	<p>(11) International Publication Number: WO 96/23767</p> <p>(43) International Publication Date: 8 August 1996 (08.08.96)</p>
<p>(21) International Application Number: PCT/IB96/00083</p> <p>(22) International Filing Date: 31 January 1996 (31.01.96)</p> <p>(30) Priority Data: 263/95-8 1 February 1995 (01.02.95) CH</p> <p>(71) Applicant (for all designated States except US): UREA CASALE S.A. [CH/CH]; Via Sorengo 7, CH-6900 Lugano-Besso (CH).</p> <p>(72) Inventors; and (75) Inventors/Applicants (for US only): PAGANI, Giorgio [IT/IT]; Viale Faenza, 26/6, I-20142 Milano (IT). ZARDI, Umberto [IT/CH]; Via Lucino 57, CH-6932 Breganzona (CH).</p> <p>(74) Agent: ZARDI, Marco; Via Sorengo 7, CH-6900 Lugano-Besso (CH).</p>	<p>(81) Designated States: AM, AT, AU, BB, BG, BR, BY, CA, CH, CN, CZ, DE, DK, EE, ES, FI, GB, GE, HU, IS, JP, KE, KG, KP, KR, KZ, LK, LR, LT, LU, LV, MD, MG, MN, MW, MX, NO, NZ, PL, PT, RO, RU, SD, SE, SG, SI, SK, TJ, TM, TT, UA, UG, US, UZ, VN, Eurasian patent (AZ, BY, KG, KZ, RU, TJ, TM), European patent (AT, BE, CH, DE, DK, ES, FR, GB, GR, IE, IT, LU, MC, NL, PT, SE).</p> <p>Published With international search report.</p>	

(54) Title: PROCESS AND PLANT FOR THE PRODUCTION OF UREA WITH HIGH CONVERSION YIELD AND LOW ENERGY CONSUMPTION

(57) Abstract

In a process for the production of urea, substantially pure ammonia and carbon dioxide are reacted in a reaction space (1) from which comes out a reaction mixture subjected to stripping (2) to obtain a partially purified mixture sent to a urea recovery section (3, 4, 7, 8). From the recovery section (3, 4, 7, 8) it is obtained a dilute carbamate solution, which is subjected to stripping (9) with recycling of vapors to the reaction space (1) after condensation (6). This process achieves high conversion yield with reduced energy consumption and low implementation costs.

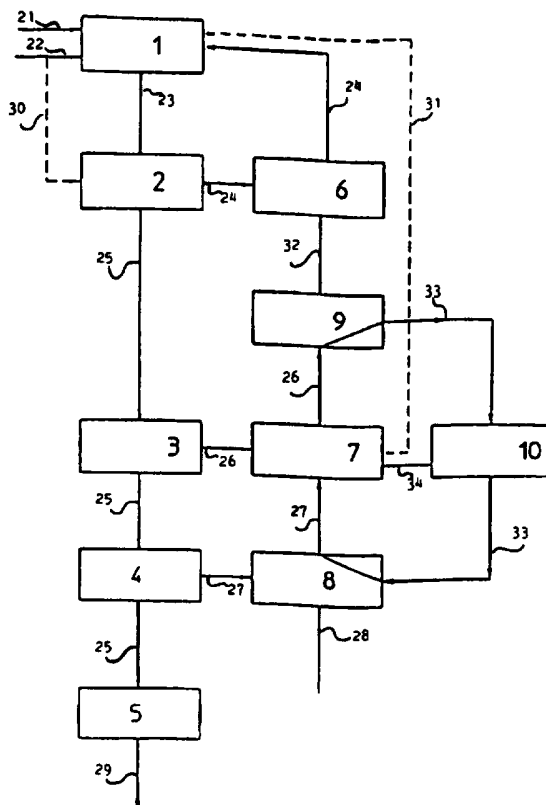

FOR THE PURPOSES OF INFORMATION ONLY

Codes used to identify States party to the PCT on the front pages of pamphlets publishing international applications under the PCT.

AM	Armenia	GB	United Kingdom	MW	Malawi
AT	Austria	GE	Georgia	MX	Mexico
AU	Australia	GN	Guinea	NE	Niger
BB	Barbados	GR	Greece	NL	Netherlands
BE	Belgium	HU	Hungary	NO	Norway
BF	Burkina Faso	IE	Ireland	NZ	New Zealand
BG	Bulgaria	IT	Italy	PL	Poland
BJ	Benin	JP	Japan	PT	Portugal
BR	Brazil	KE	Kenya	RO	Romania
BY	Belarus	KG	Kyrgystan	RU	Russian Federation
CA	Canada	KP	Democratic People's Republic of Korea	SD	Sudan
CF	Central African Republic	KR	Republic of Korea	SE	Sweden
CG	Congo	KZ	Kazakhstan	SG	Singapore
CH	Switzerland	LI	Liechtenstein	SI	Slovenia
CI	Côte d'Ivoire	LK	Sri Lanka	SK	Slovakia
CM	Cameroon	LR	Liberia	SN	Senegal
CN	China	LT	Lithuania	SZ	Swaziland
CS	Czechoslovakia	LU	Luxembourg	TD	Chad
CZ	Czech Republic	LV	Latvia	TG	Togo
DE	Germany	MC	Monaco	TJ	Tajikistan
DK	Denmark	MD	Republic of Moldova	TT	Trinidad and Tobago
EE	Estonia	MG	Madagascar	UA	Ukraine
ES	Spain	ML	Mali	UG	Uganda
FI	Finland	MN	Mongolia	US	United States of America
FR	France	MR	Mauritania	UZ	Uzbekistan
GA	Gabon			VN	Viet Nam

Title: "Process and plant for the production of urea with high conversion yield and low energy consumption"

DESCRIPTION

Technical Field

5 In its general aspect the present invention relates to a process for urea production.

The present invention relates specifically to a process for urea production of the type comprising the steps of:

- 10 - performing a reaction between ammonia and carbon dioxide in a reaction space to obtain a reaction mixture comprising urea, carbamate and free ammonia in aqueous solution;
- subjecting said mixture to a treatment of partial decomposition of the carbamate and partial separation of said free ammonia in aqueous solution to obtain a first
15 flow comprising ammonia and carbon dioxide in vapor phase and a flow comprising urea and residual carbamate in aqueous solution;
- subjecting said first flow comprising ammonia and carbon dioxide in vapor phase to at least partial condensation to
20 obtain a first portion of carbamate in aqueous solution;
- recycling said first portion of carbamate to said reaction space;
- feeding said flow comprising urea and residual carbamate in aqueous solution to a urea recovery section;
- 25 - separating in said recovery section said residual carbamate from the urea to obtain a second portion of carbamate in aqueous solution.

The present invention also relates to a plant for carrying out the above mentioned process and to a method for modernizing an existing urea plant to obtain a plant according to the present invention.

5 As known, in the field of urea production the need is ever more growing of plants having greater capacity and operating flexibility on the one hand, on the other hand, requiring ever smaller investment and operating costs, in particular in energy terms.

10 Prior Art

To this end, there have been proposed and implemented in the art a series of urea production processes essentially based on the performance of a conversion reaction in a reaction space fed with ammonia (NH_3) and carbon dioxide
15 (CO_2) and to which are recycled the unreacted substances contained in the urea solution leaving the reaction space, in particular ammonia, carbon dioxide and carbamate in aqueous solution.

A process of this type is shown in FIG. 1, and comprises
20 downstream to a reaction space, a carbamate decomposition unit and a urea recovery section for separating from the urea solution the unreacted substances to be recycled.

If, on the one hand, this recycle allows almost complete recovery of valuable substances such as ammonia and carbon
25 dioxide, on the other hand it also involves the sending to the reactor of large quantities of water (H_2O) which are detrimental to the overall yield of conversion of the carbon dioxide to urea, with the yield being generally between 59% and 63%.

30 Summary of the invention

The technical problem underlying the present invention is

accordingly to conceive and make available a process for urea production achieving high conversion yield which would be technically simple to implement and would involve low investment and operating costs.

5 In accordance with the present invention, this problem is solved by a process of the above mentioned type which is characterized in that it comprises the additional steps of:

- subjecting at least part of said second portion of carbamate in aqueous solution obtained in said recovery
10 section to a treatment of partial decomposition to obtain a second flow comprising ammonia and carbon dioxide in vapor phase and a flow comprising residual carbamate in aqueous solution;

- subjecting said second flow comprising ammonia and carbon
15 dioxide in vapor phase to at least partial condensation to obtain a third portion of carbamate in aqueous solution;

- recycling said third portion of carbamate to said reaction space.

20 According to this invention, at least part of the carbamate in aqueous solution leaving the urea recovery section is advantageously subjected to a treatment of partial decomposition separating unreacted ammonia and carbon dioxide from a solution rich in water comprising residual carbamate.

25 So doing, the unreacted substances which are recycled to the reaction space have a very low water content, and thus it is possible to substantially limit the water fed to the reaction space, permitting a high conversion yield.

30 In order to obtain a high degree of decomposition of said at least part of the second portion of carbamate in aqueous solution, the same is preferably subjected to a

decomposition treatment at a pressure substantially corresponding to the pressure in the reaction space.

To improve and assist the condensation and separation steps of the unreacted substances in the urea recovery section, the flow comprising residual carbamate in aqueous solution resulting from the treatment of partial decomposition of the second portion of carbamate is advantageously fed to said urea recovery section.

According to another embodiment of the present invention, the process comprises the steps of:

- feeding the reaction mixture comprising urea, carbamate and free ammonia in aqueous solution to a decomposition unit;
- feeding said at least part of the second portion of carbamate in aqueous solution to said decomposition unit,

wherein the treatment of partial decomposition of the reaction mixture and of the second portion of carbamate is carried out advantageously in the same decomposition unit to obtain said first and second flow comprising ammonia and carbon dioxide in vapor phase and a flow comprising urea and residual carbamate in aqueous solution.

In accordance with this embodiment, the implementation of the urea production process is technically very simple, since no relevant additional equipment is required compared to the prior art processes, and it involves low investment costs.

Particularly satisfactory results have been obtained by subjecting at least 50% and preferably at least 65% of said second portion of carbamate in aqueous solution to the treatment of partial decomposition.

According to another aspect of the present invention, the technical problem set forth above is solved by a plant designed to implement the above mentioned urea production process comprising:

- 5 - a urea synthesis reactor;
- a first stripping unit for subjecting a reaction mixture leaving said reactor to a treatment of partial decomposition of the carbamate and partial separation of the free ammonia in aqueous solution present in said
10 mixture;
- means for condensing at least partially the vapors leaving said first stripping unit and of recycling a first portion of carbamate in aqueous solution to said reactor;
- a recovery section of a flow comprising urea and residual
15 carbamate in aqueous solution leaving said first stripping unit for separating the urea produced in the reactor from a second portion of carbamate in aqueous solution;

which plant is characterized in that it comprises:

- 20 - a second stripping unit for subjecting at least part of said second portion of carbamate in aqueous solution to a treatment of partial decomposition;
- means for condensing at least partially the vapors leaving said second stripping unit and of recycling a third portion of carbamate in aqueous solution to said reactor.
- 25 In accordance with a still further embodiment of the invention, the plant for urea production comprises:
- a urea synthesis reactor;
- a stripping unit for subjecting a reaction mixture leaving said first reactor to a treatment of partial

decomposition of the carbamate and partial separation of the free ammonia in aqueous solution present in said mixture;

- means for condensing at least partially the vapors leaving said stripping unit and of recycling a first portion of carbamate in aqueous solution to said first reactor;

- a recovery section of a flow comprising urea and residual carbamate in aqueous solution leaving said stripping unit for separating the urea produced in the reactor from a second portion of carbamate in aqueous solution;

which plant is characterized in that it comprises:

- means for feeding at least part of said second portion of carbamate in aqueous solution to the stripping unit.

In accordance with the present invention the plants delegated to carry out the urea production process may be provided either new or by modifying pre-existing plants so as to obtain a production capacity expansion and at the same time improved performance from the energy consumption viewpoint.

According to another aspect, the present invention accordingly makes available a method for modernizing a urea production plant of the type comprising:

- a urea synthesis reactor;

- a first stripping unit for subjecting a reaction mixture leaving said reactor to a treatment of partial decomposition of the carbamate and partial separation of the free ammonia in aqueous solution present in said mixture;

- means for condensing at least partially the vapors leaving said first stripping unit and of recycling a first portion of carbamate in aqueous solution to said reactor;

5 - a recovery section of a flow comprising urea and residual carbamate in aqueous solution leaving said first stripping unit for separating the urea produced in the reactor from a second portion of carbamate in aqueous solution;

which method is characterized in that it comprises the steps of:

10 - providing a second stripping unit for subjecting at least part of said second portion of carbamate in aqueous solution to a treatment of partial decomposition;

15 - providing means for condensing at least partially the vapors leaving said second stripping unit and of recycling a third portion of carbamate in aqueous solution to said reactor.

In an alternative embodiment, the modernization method of the present invention comprises the steps of :

20 - providing a second stripping unit for subjecting at least part of said second portion of carbamate in aqueous solution to a treatment of partial decomposition;

- providing means for feeding the vapors leaving said second stripping unit to said means for condensing the vapors leaving said first stripping unit.

25 According to a further embodiment, the modernization method of the present invention comprises the step of:

- providing means for feeding at least part of said second portion of carbamate in aqueous solution to the stripping unit.

Further characteristics and advantages of the present invention are set forth in the detailed description of some preferred embodiments thereof given below by way of non-limiting example with reference to the annexed drawings.

5 Brief description of the drawings

In the drawings:

- FIG. 1 shows a block diagram of a urea production process according the prior art;
- FIG. 2 shows a block diagram of a first embodiment of the urea production process according to present invention; and
- 10 - FIG. 3 shows a block diagram of a second embodiment of the urea production process according to the present invention.

Detailed description of a preferred embodiment

- 15 FIG. 1 shows a block diagram illustrating the steps of a urea production process according to the prior art.

Block 1 indicates a high pressure reaction space for the synthesis of urea which is fed by gas flows 21 and 22 comprising substantially pure ammonia and carbon dioxide

20 respectively.

Typical operating conditions in the reaction space are:

- molar ratio NH_3/CO_2 at input: 2.9 to 3.4;
- molar ratio $\text{H}_2\text{O}/\text{CO}_2$ at input: 0.4 to 0.7;
- conversion yield of the CO_2 into urea: 59% to 63%;
- 25 • pressure: 150 bar a;
- temperature: 185°C to 190°C.

Blocks 2, 5 and 6 indicate respectively a high pressure decomposition unit, a urea granulation or prilling section and a high pressure condensation unit.

5 The decomposition and condensation units 2 and 6 generally operates at the same pressure conditions as the reaction space 1.

10 A urea recovery section is generally indicated by blocks 3, 4, 7 and 8. In particular, blocks 3 and 4 indicate a stripping or distillation unit and blocks 7 and 8 indicate a condensation unit.

Block 4 also indicates a urea finishing unit, wherein a solution with an urea content of up to 99.7% is obtained.

15 Block 8 also indicates a waste water treatment unit for purification of the water to be discharged from the urea production process.

Typically, blocks 3 and 7 operate at medium pressure (about 18 bar), while blocks 4 and 8 operate at low pressure (about 4 bar).

20 Flow line 23 represents a liquid flow of a reaction mixture coming from block 1 and comprising urea and unreacted substances, notably carbamate and free ammonia in aqueous solution.

25 The liquid flow 23 is fed to block 2, where it is subjected to a treatment of partial decomposition of the carbamate and partial separation of the free ammonia.

The decomposition unit indicated by block 2 generally comprises a stripper apparatus which operates with a flow 30 of carbon dioxide as stripping agent coming from the flow line 22.

At the outlet of block 2, flow lines 24 and 25 are shown which represent respectively a gas flow comprising ammonia and carbon dioxide in vapor phase and a liquid flow comprising urea and residual carbamate in aqueous solution.

5 Flow line 24 traverses the condensation unit represented by block 6, where the ammonia and carbon dioxide in vapor phase are condensed obtaining a flow of carbamate in aqueous solution which is recycled to the reaction space 1.

10 The flow comprising urea and residual carbamate in aqueous solution indicated by flow line 25 traverses the distillation units of the urea recovery section indicated by blocks 3 and 4, where the residual carbamate is decomposed and separated from the urea solution.

15 Generally, the urea content in the liquid flow 25 is between 70%-72% after block 3 and about 99% after block 4.

Flow lines 26 and 27 represent a gas flow comprising ammonia and carbon dioxide in gaseous phase obtained in blocks 3 and 4 respectively.

20 The flow 27 traverses the condensation unit represented by block 8, where the ammonia and carbon dioxide in vapor phase are condensed obtaining a flow of carbamate in aqueous solution, and is fed to the condensation unit 7, where it promotes condensation of the gas flow 26.

25 Analogously, the flow 26 traverses the condensation unit represented by block 7, where the ammonia and carbon dioxide in vapor phase are condensed obtaining a flow of carbamate in aqueous solution, and is fed to the condensation unit 6, where it promotes condensation of the gas flow 24.

30 Part of the water contained in the aqueous solution obtained in the condensation unit of block 8 is further

treated and purified of almost all traces of ammonia and urea in the treatment unit also indicated by block 8. From block 8 departs a flow line 28 of a waste water flow to be discharged from the urea production process.

5 Finally, the urea solution flow 25 coming from block 4 traverses the granulation or prilling section indicated by block 5, where it is transformed to a final product leaving the urea production process by flow line 29.

10 In accordance with an alternative embodiment of the prior art process, block 7 also indicates an ammonia separation column to obtain a substantially pure liquid ammonia which is sent to the reaction space 1 in addition to the flow 21, as indicated by flow line 31 in FIG. 1.

15 As shown in FIG. 1, in the urea production process according to the prior art, all the carbamate containing aqueous solution separated from the urea is recycled to the reaction space 1, with the large amount of water therein contained being used for condensation and conveyance of the unreacted substances.

20 In FIGS. 2 and 3, it is indicated a block diagram of a first respectively second embodiment of the urea production process according to the present invention.

25 In said figures the details of the block diagram structurally and functionally equivalent to those shown in FIG. 1 are indicated by the same reference numbers and not further described.

In FIG. 2, block 9 indicates a high pressure decomposition unit operating at the same pressure conditions as the reaction space 1.

30 The liquid flow 26 containing carbamate in aqueous solution and having a high water content is fed to block 9, where it

is advantageously subjected to a treatment of partial decomposition of the carbamate.

At the outlet of block 9, flow lines 32 and 33 are shown which represent respectively a gas flow comprising ammonia and carbon dioxide in vapor phase and a liquid flow
5 comprising urea and residual carbamate in aqueous solution.

The gas flow 32, which is very rich in ammonia and carbon dioxide and poor in water (only a few percentages points), traverses the condensation unit represented by block 6,
10 where ammonia and carbon dioxide are condensed obtaining a flow of carbamate in aqueous solution, and is recycled to the reaction space 1 through flow line 24.

In the example of FIG. 2, all the carbamate in aqueous solution separated from the urea in the recovery section is
15 subjected to the decomposition treatment in block 9. However, satisfactory results have been obtained also by feeding to block 9 only a part of carbamate leaving the urea recovery section. Preferably, at least 50% of this carbamate may be sent to block 9.

20 According to the process of the present invention, a reaction between ammonia and carbon dioxide is performed in reaction space 1 obtaining a reaction mixture comprising urea, carbamate and free ammonia in aqueous solution, which is subjected in decomposition unit 2 to a treatment of
25 partial decomposition of the carbamate and partial separation of said free ammonia in aqueous solution. From the decomposition unit 2 departs a first flow 24 comprising ammonia and carbon dioxide in vapor phase and a flow 25 comprising urea and residual carbamate in aqueous solution.
30 The flow 24 is then subjected to at least partial condensation in block 6 to obtain a first portion of carbamate in aqueous solution which is recycled to the reaction space 1. The flow 25 is on the contrary fed to a

urea recovery section (blocks 3, 4, 7 and 8) where the urea is separated from a second portion of carbamate in aqueous solution indicated by flow line 26.

5 Advantageously, in accordance with other process steps of the present invention, at least part of the flow 26 is further subjected to a treatment of partial decomposition in block 9 to obtain a second flow 32 comprising ammonia and carbon dioxide in vapor phase and a flow 33 comprising residual carbamate in aqueous solution. The flow 32 is then
10 at least partially condensed in block 6 to obtain a third portion of carbamate in aqueous solution recycled to the reaction space via flow line 24.

By operating in this manner it is possible to obtain a high conversion yield in the reaction space since a highly
15 concentrated solution of carbamate which is very poor in water is recycled to the same.

According to the present urea production process, it is possible to achieve a conversion yield of carbon dioxide to urea of about 70% to 75%, which is notably greater than
20 that obtainable with the prior art processes.

Moreover, this high conversion yield and the substantially absence of water to be recycled to the reaction space 1 also result in a smaller flow of substances to be separated from the urea solution, and thus it result in an increase
25 in the performance of the decomposition unit 2 and of the distillation units 3 and 4 of the recovery section.

In the example of FIG. 2, the liquid flow 33, which is very rich in water, is advantageously recycled to the urea recovery section in order to promote condensation and
30 recover of the unreacted substances which are freed in the distillation units 3 and 4.

Preferably, flow line 33 traverses a distillation unit indicated by block 10, where the residual carbamate is further subjected to decomposition in order to obtain a solution very rich in water which is fed to block 8.

- 5 From block 10 also departs a flow line 34 of a water poor vapor flow comprising residual ammonia and carbon dioxide which is fed to the condensation unit indicated by block 7 of the recovery section.

10 There is thus obtained a separate circulation loop of process water which advantageously promotes condensation of ammonia and carbon dioxide vapors in units 7 and 8 without being recycled to the reaction space 1 and thus without negatively affecting the reaction between ammonia and carbon dioxide.

- 15 In the alternative embodiment of the process according to the present invention disclosed in FIG. 3, the flow line 26 coming from the urea recovery section, namely the condensation unit 7, instead of being recycled directly to the reaction space 1 through block 6 as in the prior art
20 process, it is advantageously fed to the decomposition unit indicated by block 2, where a flow of ammonia and carbon dioxide in vapor phase is obtained which is recycled via flow line 24 to the reaction space 1 after condensation in the block 6.

- 25 So doing, the treatment of partial decomposition of the second portion of carbamate in aqueous solution (flow 26) is carried out in the same decomposition unit of the reaction mixture (flow 23), thereby permitting an
30 implementation of the process according to the present invention which does not require the use of relevant additional equipment if compared to the prior art.

As stripping agents for the decomposition unit 2 it can

also be used a part of the ammonia flow fed to the reaction space. Alternatively, the block 2 can be operated in a self-stripping mode, wherein the evaporated ammonia promotes the decomposition of the carbamate.

5 Moreover, the urea recovery section may only comprises the low pressure units 4 and 8. In this case, the flow comprising urea and residual carbamate in aqueous solution coming from the decomposition unit 2 is fed directly to block 4 for final separation of the urea solution from the
10 unreacted substances.

Reference is now made to a plant for urea production specifically designed to carry out the process according to the present invention.

The urea production plant advantageously comprises a urea
15 synthesis reactor indicated by block 1, a first and a second stripping unit indicated by blocks 2 and 9 respectively, a urea recovery section indicated by blocks 3, 4, 7 and 8, and respective means for condensing and recycling to the reactor the vapors leaving the first and
20 the second stripping unit.

With reference to the embodiment of FIG. 2, the means for condensing the vapors leaving the second stripping unit 9 preferably comprises the means for condensing the vapors leaving the first stripping unit 2 and is indicated by
25 block 6.

A distiller unit indicated by block 10 is also disposed between the second stripping unit and the recovery section.

With reference to the embodiment of FIG. 3, the urea
30 production plant comprises feeding means indicated by flow line 26 between the recovery section and the stripping unit 2. In this case the stripping unit 9 and the distiller unit

10 are not needed.

The plant designed to implement the process for urea production in accordance with the present invention may be a brand new plant or a plant obtained by modernizing a pre-existing plant such as the plant resulting from the
5 implementation of the process illustrated in the block diagram of FIG. 1.

According to a first embodiment, this modernization takes place by means for the steps of:

- 10 - providing a second stripping unit (block 9) for subjecting at least part of the carbamate in aqueous solution leaving the recovery section (flow line 26) to a treatment of partial decomposition;
- providing means for condensing at least partially the
15 vapors leaving said second stripping unit and of recycling the so obtained high concentrated carbamate solution to the reactor (block 1).

In accordance with another embodiment of the invention, the modernizing method preferably comprises the step of:

- 20 - providing means for feeding the vapors leaving the second stripping unit (block 9) directly to the means for condensing the vapors leaving the first stripping unit 2, represented by block 6.

Advantageously, the method for modernizing a pre-existing
25 plant additionally comprise the step of:

- providing means for feeding (flow line 33) a flow comprising residual carbamate in aqueous solution from the second stripping unit (block 9) to the urea recovery section.

In a particular and advantageous embodiment of the present invention, the modernizing method comprises the step of:

- providing means for feeding (flow line 26) at least part of the carbamate solution coming from the urea recovery section to the stripping unit indicated by block 2.

Thanks to the modernizing method of the present invention, not only the conversion yield of the pre-existing urea synthesis reactor can be drastically increased but also its capacity.

- 10 In fact, since only a very small amount of water is recycled to the reactor 1, a bigger flow of ammonia and carbon dioxide may be fed to the same without causing a capacity overcharge in the reactor itself as well as in the decomposition unit 2 and in the distillation units 3 and 4
- 15 of the recovery section.

- In the next examples there are compared by way of merely indicative and non limiting example the conversion yields obtainable by a plant implementing the process according to the present invention or modernized by the method of the present invention and by a plant implementing the process according to the prior art.

EXAMPLE 1

- A pre-existing plant operating according to the prior art process described with reference to FIG. 1 is modernized in order to operate according to the process described with reference to FIG. 2.

- The pre-existing plant is based on the so-called ammonia self-stripping process, wherein no ammonia or carbon dioxide stripping agent is fed to the decomposition unit indicated by block 2. Therefore, in this case flow line 30 is missing.

The operation conditions of the urea synthesis reactor before the plant modernization are the followings:

- molar ratio NH_3/CO_2 at input: 3.2;
- molar ratio $\text{H}_2\text{O}/\text{CO}_2$ at input: 0.6;
- 5 • conversion yield of the CO_2 into urea: 61%;
- pressure: about 150 bar a;
- temperature: 190°C;
- capacity: 1800 MTD urea

10 After modernizing the pre-existing plant by providing a second stripping unit 9 fed with 77% of the carbamate solution coming from the urea recovery section, and by feeding the vapors leaving said second stripping unit to the reactor space 1 via the condenser unit 6, as described with reference to FIG. 2, the new operating conditions of
15 the reactor are the followings:

- molar ratio NH_3/CO_2 at input: 3.2;
- molar ratio $\text{H}_2\text{O}/\text{CO}_2$ at input: 0.19;
- conversion yield of the CO_2 into urea: 70%;
- pressure: about 150 bar a;
- 20 • temperature: 190°C;
- capacity: 2500 MTD urea

Thanks to the present invention, it is possible to increase the conversion yield of 9 points percentage and to increase the capacity of 700 MTD urea, i.e. 39% more than the
25 original capacity.

Such a relevant increase in the conversion yield and the much lower amount of water recycled to the reactor allow to obtain the new increased capacity with only minor modifications to the pre-existing plant and with low investment costs. Moreover, this high conversion yield also results in a reduction in energy consumption of the modernized plant.

EXAMPLE 2

A pre-existing plant operating according to the prior art process described with reference to FIG. 1 is modernized in order to operate according to the process described with reference to FIG. 2.

The pre-existing plant is based on the carbon dioxide stripping process, wherein a flow of carbon dioxide as stripping agent is fed to the decomposition unit indicated by block 2 (flow line 30). In this case, the ammonia separation unit comprised in block 7 and flow line 31 are missing. Also units 3 and 7 are missing, and the urea recovery section only comprises the low pressure units 4 and 8.

The operation conditions of the urea synthesis reactor before the plant modernization are the followings:

- molar ratio NH_3/CO_2 at input: 3.0;
- molar ratio $\text{H}_2\text{O}/\text{CO}_2$ at input: 0.5;
- conversion yield of the CO_2 into urea: about 60%;
- pressure: about 145 bar a;
- temperature: 185°C;
- capacity: 1900 MTD urea

After modernizing the pre-existing plant by providing a second stripping unit 9 fed with 70% of the carbamate solution coming from the urea recovery section, and by feeding the vapors leaving said second stripping unit to the reactor space 1 via the condenser unit 6, as described with reference to FIG. 2, the new operating conditions of the reactor are the followings:

- molar ratio NH_3/CO_2 at input: 3.0;
- molar ratio $\text{H}_2\text{O}/\text{CO}_2$ at input: 0.25;
- 10 • conversion yield of the CO_2 into urea: 66%;
- pressure: about 150 bar a;
- temperature: 190°C;
- capacity: 2500 MTD urea

Thanks to the present invention, it is possible to increase the conversion yield of 6 points percentage and to increase the capacity of 600 MTD urea, i.e. 32% more than the original capacity.

Also in this case, only minor modifications to the pre-existing plant and low investment costs are required to obtain a relevant increase in the capacity and the conversion yield.

EXAMPLE 3

In this example, the conversion yield of a reactor operating in a brand new plant implementing the process according to the present invention as described in FIG. 2 has been simulated.

As for the above example 2, the plant is based on the carbon dioxide stripping process, wherein all the carbon

dioxide to be fed to the reactor 1 is first fed as stripping agent in the decomposition unit indicated by block 2 through flow line 30. In this case, flow line 22 is missing as well as the ammonia separation unit comprised in block 7 and flow line 31. The urea recovery section comprises the medium and low pressure units 3, 4, 7 and 8.

The operation conditions of the reactor in the urea production plant according to the present invention are the followings:

- molar ratio NH_3/CO_2 at input: 3.2;
- molar ratio $\text{H}_2\text{O}/\text{CO}_2$ at input: 0.1;
- pressure: about 150 bar a;
- temperature: 190°C;
- capacity: 400 MTD urea

The conversion yield of the CO_2 into urea obtained by the present reactor is very high: 72%. Moreover, the content of water in the carbamate solution recycled to the reactor is particularly low.

Since low amounts of water and unreacted substances are contained in the reaction mixture sent to the decomposition unit and further to the recovery section, it results that the duties of the process equipment are lower if compared to the conventional plants and consequently also the energy consumption and the investment costs.

*** * ***

The results given in the above examples have been obtained by means for well known calculation algorithms.

CLAIMS

1. Process for urea production of the type comprising the steps of:

- 5 - performing a reaction between ammonia and carbon dioxide in a reaction space to obtain a reaction mixture comprising urea, carbamate and free ammonia in aqueous solution;
- 10 - subjecting said mixture to a treatment of partial decomposition of the carbamate and partial separation of said free ammonia in aqueous solution to obtain a first flow comprising ammonia and carbon dioxide in vapor phase and a flow comprising urea and residual carbamate in aqueous solution;
- 15 - subjecting said first flow comprising ammonia and carbon dioxide in vapor phase to at least partial condensation to obtain a first portion of carbamate in aqueous solution;
- recycling said first portion of carbamate to said reaction space;
- feeding said flow comprising urea and residual carbamate in aqueous solution to a urea recovery section;
- 20 - separating in said recovery section said residual carbamate from the urea to obtain a second portion of carbamate in aqueous solution;

characterized in that it comprises the additional steps of:

- 25 - subjecting at least part of said second portion of carbamate in aqueous solution obtained in said recovery section to a treatment of partial decomposition to obtain a second flow comprising ammonia and carbon dioxide in vapor phase and a flow comprising residual carbamate in aqueous solution;

- subjecting said second flow comprising ammonia and carbon dioxide in vapor phase to at least partial condensation to obtain a third portion of carbamate in aqueous solution;

5 - recycling said third portion of carbamate to said reaction space.

2. Process according to claim 1, characterized in that the treatment of partial decomposition of the said at least part of the second portion of carbamate in aqueous solution is carried out at a pressure substantially corresponding to
10 the pressure in the reaction space.

3. Process according to claim 1, characterized in that it further comprises the step of:

15 - feeding the flow comprising residual carbamate in aqueous solution resulting from the treatment of partial decomposition of the second portion of carbamate to said urea recovery section.

4. Process according to claim 1, characterized in that it comprises the steps of:

20 - feeding the reaction mixture comprising urea, carbamate and free ammonia in aqueous solution to a decomposition unit;

- feeding said at least part of the second portion of carbamate in aqueous solution to said decomposition unit,

25 wherein the treatment of partial decomposition of the reaction mixture and of the second portion of carbamate is carried out in the same decomposition unit to obtain said first and second flow comprising ammonia and carbon dioxide in vapor phase and a flow comprising urea and residual carbamate in aqueous solution.

5. Process according to claim 1, characterized in that at least 50% of said second portion of carbamate in aqueous solution is subjected to the treatment of partial decomposition.

5 6. Process according to claim 5, characterized in that at least 65% of said second portion of carbamate in aqueous solution is subjected to the treatment of partial decomposition.

7. Plant for urea production comprising:

10 - a urea synthesis reactor (1);

- a first stripping unit (2) for subjecting a reaction mixture leaving said reactor (1) to a treatment of partial decomposition of the carbamate and partial separation of the free ammonia in aqueous solution present in said
15 mixture;

- means (6) for condensing at least partially the vapors leaving said first stripping unit (2) and of recycling (24) a first portion of carbamate in aqueous solution to said reactor (1);

20 - a recovery section (3, 4, 7, 8) of a flow comprising urea and residual carbamate in aqueous solution leaving said first stripping unit (2) for separating the urea produced in the reactor (1) from a second portion of carbamate in aqueous solution;

25 characterized in that it comprises:

- a second stripping unit (9) for subjecting at least part of said second portion of carbamate in aqueous solution to a treatment of partial decomposition;

- means for condensing at least partially the vapors

leaving said second stripping unit (9) and of recycling a third portion of carbamate in aqueous solution to said reactor (1).

8. Plant according to claim 7, characterized in that said means for condensing the vapors leaving said second stripping unit (9) comprises said means (6) for condensing the vapors leaving said first stripping unit (2).

9 Plant according to claim 7, characterized in that it further comprises:

10 - means (33) for feeding a flow comprising residual carbamate in aqueous solution from said second stripping unit (9) to said recovery section (3, 4, 7, 8).

10. Plant for urea production comprising:

- a urea synthesis reactor (1);

15 - a stripping unit (2) for subjecting a reaction mixture leaving said first reactor (1) to a treatment of partial decomposition of the carbamate and partial separation of the free ammonia in aqueous solution present in said mixture;

20 - means (6) for condensing at least partially the vapors leaving said stripping unit (2) and of recycling a first portion of carbamate in aqueous solution to said first reactor (1);

25 - a recovery section (3, 4, 7, 8) of a flow comprising urea and residual carbamate in aqueous solution leaving said stripping unit (2) for separating the urea produced in the reactor (1) from a second portion of carbamate in aqueous solution;

characterized in that it comprises:

- means for feeding (26) at least part of said second portion of carbamate in aqueous solution to the stripping unit (2).

11. Method for modernizing a plant for urea production of
5 the type comprising:

- a urea synthesis reactor (1);

- a first stripping unit (2) for subjecting a reaction
mixture leaving said reactor (1) to a treatment of partial
decomposition of the carbamate and partial separation of
10 the free ammonia in aqueous solution present in said
mixture;

- means (6) for condensing at least partially the vapors
leaving said first stripping unit (2) and of recycling a
first portion of carbamate in aqueous solution to said
15 reactor (1);

- a recovery section (3, 4, 7, 8) of a flow comprising urea
and residual carbamate in aqueous solution leaving said
first stripping unit (2) for separating the urea produced
in the reactor (1) from a second portion of carbamate in
20 aqueous solution;

characterized in that it comprises the steps of:

- providing a second stripping unit (9) for subjecting at
least part of said second portion of carbamate in aqueous
solution to a treatment of partial decomposition;

25 - providing means for condensing at least partially the
vapors leaving said second stripping unit (9) and of
recycling a third portion of carbamate in aqueous solution
to said reactor (1).

12. Method for modernizing a plant for urea production of

the type comprising:

- a urea synthesis reactor (1);
- a first stripping unit (2) for subjecting a reaction mixture leaving said reactor (1) to a treatment of partial decomposition of the carbamate and partial separation of the free ammonia in aqueous solution present in said mixture;
- means (6) for condensing at least partially the vapors leaving said first stripping unit (2) and of recycling a first portion of carbamate in aqueous solution to said reactor (1);
- a recovery section (3, 4, 7, 8) of a flow comprising urea and residual carbamate in aqueous solution leaving said first stripping unit (2) for separating the urea produced in the reactor (1) from a second portion of carbamate in aqueous solution;

characterized in that it comprises the steps of:

- providing a second stripping unit (9) for subjecting at least part of said second portion of carbamate in aqueous solution to a treatment of partial decomposition;
- providing means for feeding (32) the vapors leaving said second stripping unit (9) to said means for condensing (6) the vapors leaving said first stripping unit (2).

13. Method according to claim 11 or 12, characterized in that it further comprises the step of:

- providing means for feeding (33) a flow comprising residual carbamate in aqueous solution from said second stripping unit (9) to said recovery section (3, 4, 7, 8).

14. Method for modernizing a plant for urea production of

the type comprising:

- a urea synthesis reactor (1);
- a stripping unit (2) for subjecting a reaction mixture leaving said first reactor (1) to a treatment of partial decomposition of the carbamate and partial separation of the free ammonia in aqueous solution present in said mixture;
- means (6) for condensing at least partially the vapors leaving said stripping unit (2) and of recycling a first portion of carbamate in aqueous solution to said first reactor (1);
- a recovery section (3, 4, 7, 8) of a flow comprising urea and residual carbamate in aqueous solution leaving said stripping unit (2) for separating the urea produced in the reactor (1) from a second portion of carbamate in aqueous solution;

characterized in that it comprises the step of:

- providing means for feeding (26) at least part of said second portion of carbamate in aqueous solution to the stripping unit (2).

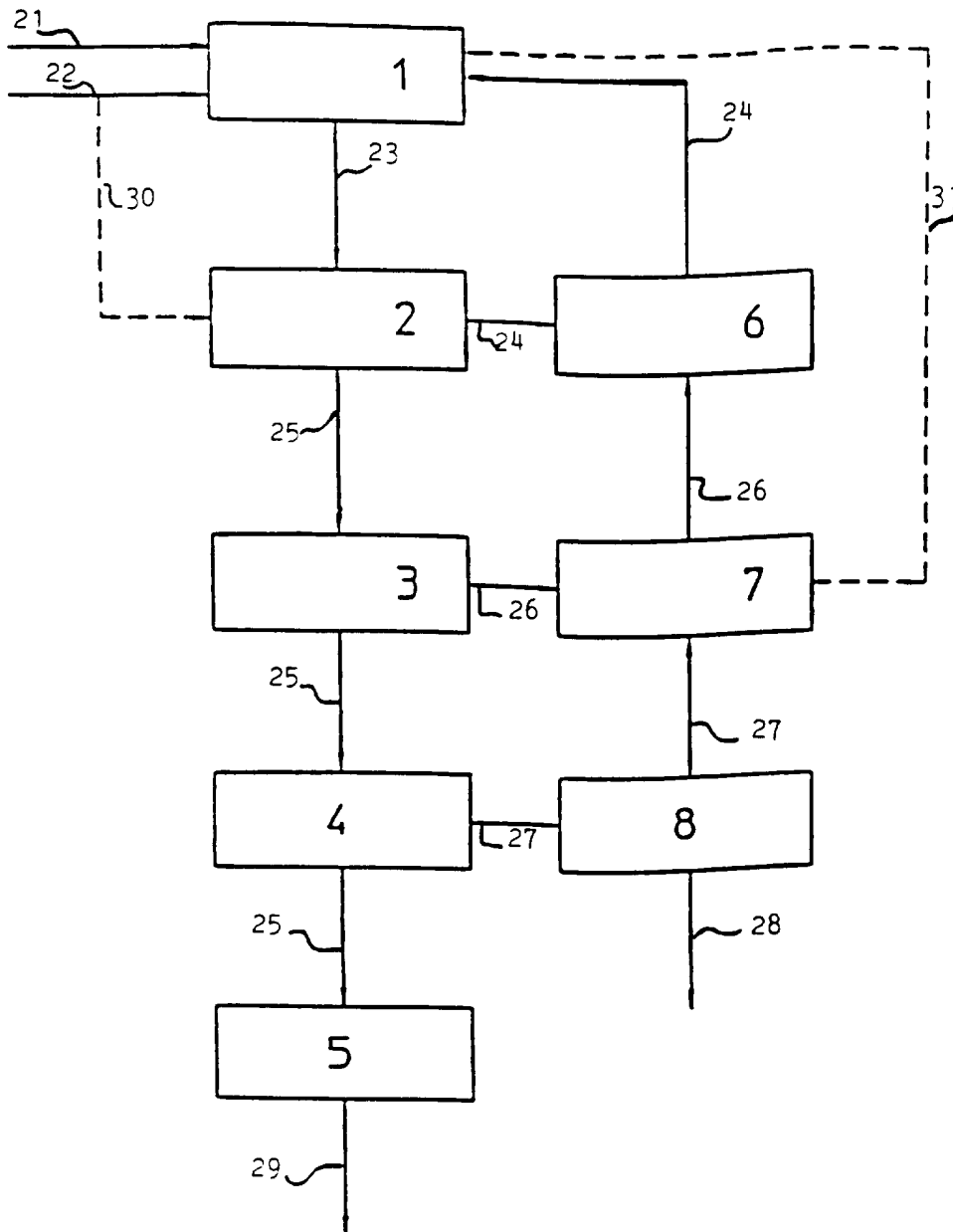

FIG. 1

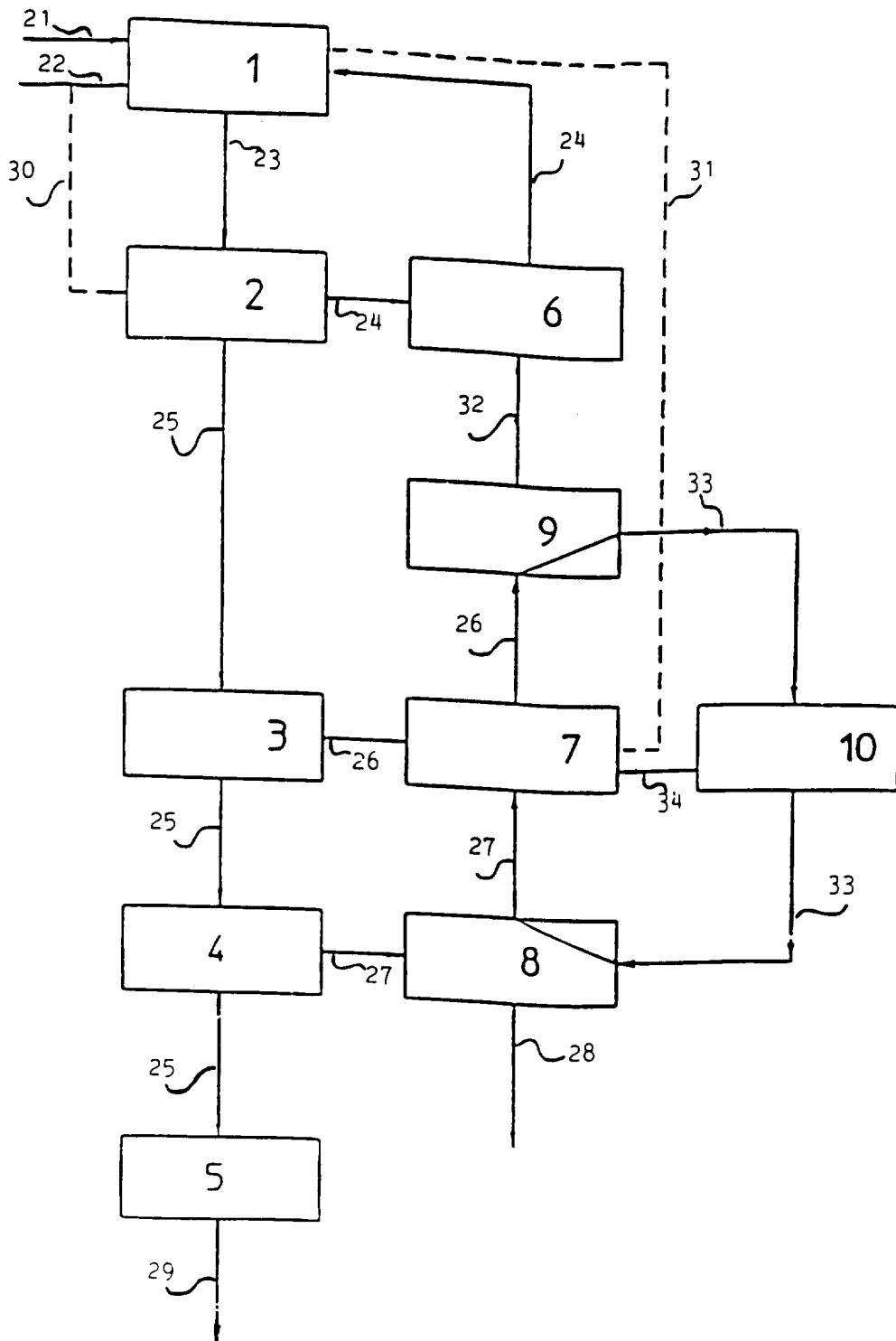

FIG. 2

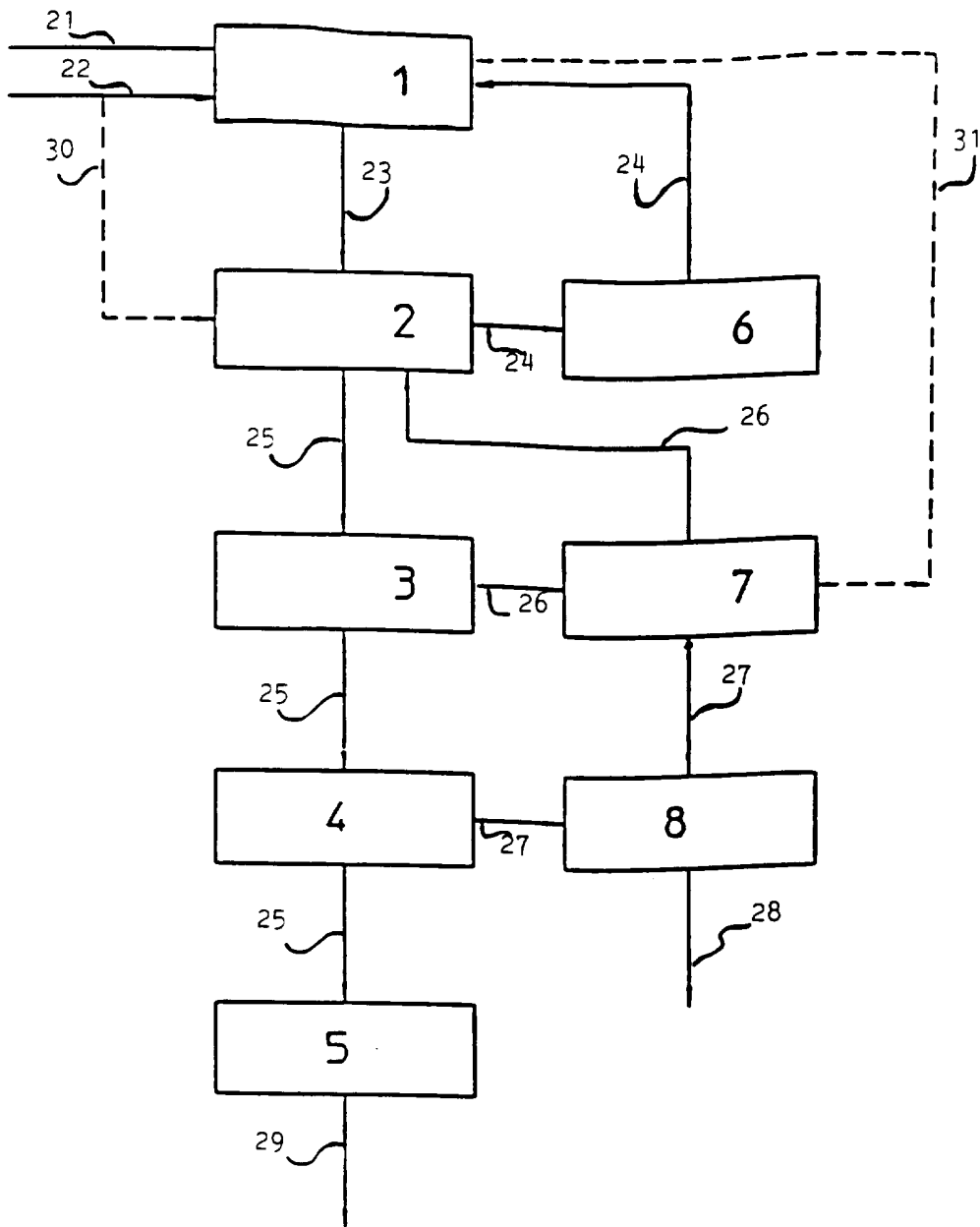

FIG. 3

INTERNATIONAL SEARCH REPORT

International Application No
PCT/IB 96/00083

A. CLASSIFICATION OF SUBJECT MATTER
IPC 6 C07C273/04

According to International Patent Classification (IPC) or to both national classification and IPC

B. FIELDS SEARCHED

Minimum documentation searched (classification system followed by classification symbols)
IPC 6 C07C

Documentation searched other than minimum documentation to the extent that such documents are included in the fields searched

Electronic data base consulted during the international search (name of data base and, where practical, search terms used)

C. DOCUMENTS CONSIDERED TO BE RELEVANT

Category *	Citation of document, with indication, where appropriate, of the relevant passages	Relevant to claim No.
Y	US,A,4 504 679 (INOUE SHIGERU ET AL) 12 March 1985 see the whole document ---	1-14
Y	US,A,4 354 040 (INOUE SHIGERU ET AL) 12 October 1982 see the whole document ---	1-14
Y	EP,A,0 212 744 (STAMICARBON) 4 March 1987 see the whole document -----	1-14

Further documents are listed in the continuation of box C.

Patent family members are listed in annex.

* Special categories of cited documents :

"A" document defining the general state of the art which is not considered to be of particular relevance
"E" earlier document but published on or after the international filing date
"L" document which may throw doubts on priority claim(s) or which is cited to establish the publication date of another citation or other special reason (as specified)
"O" document referring to an oral disclosure, use, exhibition or other means
"P" document published prior to the international filing date but later than the priority date claimed

"T" later document published after the international filing date or priority date and not in conflict with the application but cited to understand the principle or theory underlying the invention
"X" document of particular relevance; the claimed invention cannot be considered novel or cannot be considered to involve an inventive step when the document is taken alone
"Y" document of particular relevance; the claimed invention cannot be considered to involve an inventive step when the document is combined with one or more other such documents, such combination being obvious to a person skilled in the art.
"&" document member of the same patent family

Date of the actual completion of the international search

3 May 1996

Date of mailing of the international search report

24.05.96

Name and mailing address of the ISA

European Patent Office, P.B. 5818 Patentlaan 2
NL - 2280 HV Rijswijk
Tel. (+ 31-70) 340-2040, Tx. 31 651 epo nl,
Fax: (+ 31-70) 340-3016

Authorized officer

Janus, S

INTERNATIONAL SEARCH REPORT

Information on patent family members

International Application No
PCT/IB 96/00083

Patent document cited in search report	Publication date	Patent family member(s)	Publication date
US-A-4504679	12-03-85	JP-C- 1404918	09-10-87
		JP-A- 58067661	22-04-83
		JP-B- 62015070	06-04-87
		AR-A- 227990	30-12-82
		DE-A- 3237653	19-05-83
		FR-A- 2514759	22-04-83
		GB-A,B 2109372	02-06-83
		NL-A- 8203941	16-05-83
US-A-4354040	12-10-82	JP-C- 1348491	13-11-86
		JP-A- 57050954	25-03-82
		JP-B- 61016384	30-04-86
		CA-A- 1174692	18-09-84
		DE-A- 3136137	22-04-82
		FR-A,B 2490224	19-03-82
		GB-A,B 2083472	24-03-82
		NL-A- 8104158	01-04-82
EP-A-0212744	04-03-87	NL-A- 8502227	02-03-87
		AU-B- 592360	11-01-90
		AU-B- 6103986	19-02-87
		BG-A- 45384	15-05-89
		JP-A- 62039559	20-02-87
		OA-A- 8383	29-02-88
		SU-A- 1494865	15-07-89
		US-A- 4801745	31-01-89